





# eComfort MC

Air cooled liquid chiller and heat pump

## Application guide



 220 - 400 kW  
 220 - 450 kW

eCOMFORT-MC-UPGRADE-AGU-2310-EN



LENNOX participates in the ECP programme for RT.  
Check ongoing validity of certificate :  
[www.eurovent-certification.com](http://www.eurovent-certification.com)

3	GENERAL DESCRIPTION
13	OPTIONS AND ACCESSORIES
22	GENERAL DATA
24	TECHNICAL DATA
28	HYDRAULIC EQUIPMENT
41	PARTIAL HEAT RECOVERY
42	SOUND POWER LEVEL
44	OPERATING LIMITS
46	ELECTRICAL DATA
47	DIMENSIONAL DATA



Product designed and manufactured under :

- Quality management system: ISO 9001
- Environmental management system: ISO 14001.
- Occupational health and safety management systems : OHSAS 18001



[www.eurovent-certification.com](http://www.eurovent-certification.com)  
[www.certiflash.com](http://www.certiflash.com)



Our company's products comply with European standards

All the technical and technological information contained in this manual, including any drawing and technical descriptions provided by us, remain the property of Lennox and must not be utilised (except in operation of this product), reproduced, issued to or made available to third parties without the prior written agreement of Lennox.

\*For out of EEC countries, non CE marked, and non EUROVENT certified units are available on request, please consult us.



**THE EXPERIENCE & COMMITMENT OF THE EUROPEAN LEADER TO DRIVE CONTINUOUS ENERGY SAVINGS**

Lennox contribution to combat rising energy costs and global warming is to design innovative, efficient and dependable products, while providing best comfort and air quality.

As a major player in the European HVAC market, Lennox is a reference in sustainable development and has been assembling its products in ISO-14001 certified factories since 2007.

The eCOMFORT complete range is Eurovent certified.

**APPLICATION**

The eCOMFORT range is perfect for air conditioning applications in tertiary and commercial buildings such as offices, hotels, shops and restaurants as well as for cooling processes in, for example, industrial, medical, food, winemaking and data centre environments.



Non-food retail



Shopping malls



Office buildings



Hotels



Industry



Hospitals



Data Centres

**LOWER ENERGY BILLS**

The eCOMFORT water chillers and heat pumps have been optimized so you don't need to worry about your energy bill.

In thermal comfort applications, 80% of the operating times are between -2 and 10°C outside air in heating mode and 17 and 26°C in cooling mode.

The eCOMFORT units have been optimized primarily for these partial load operating conditions.

The eCOMFORT range therefore offers seasonal energy efficiencies (SEER & SCOP) that exceed the European ecodesign requirements for 2021 (cooling mode) and 2017 (heating mode).

These seasonal energy efficiencies refer to the ratio between the annual requirements of buildings in cooling or heating and the annual electricity consumption. The high seasonal energy efficiencies of the eCOMFORT range help reduce your energy bill by 12% to 15% on average compared to a traditional unit and, therefore, facilitate a rapid return on investment.

The scenario is similar in industrial cooling applications, where 90% of the operating times are between -2°C and 25°C outside air.

The eCOMFORT units, in conjunction with variable air flow control, ensure the best SEPR seasonal energy efficiencies, which exceed the European requirements for 2021 regarding high-temperature process cooling (7°C outlet water temperature) and for 2018 regarding medium temperature process cooling (-8°C outlet water temperature).



F-GAS DIRECTIVE RELATED TO THE EU REGULATION NO. 517/2014

It entered in force in January 2015, to contribute to the reduction of the global warming by limiting the use of HFCs.

High GWP refrigerants may have a speculative price increase after each quota, due to the reduced availability of bulk HFC on the market.

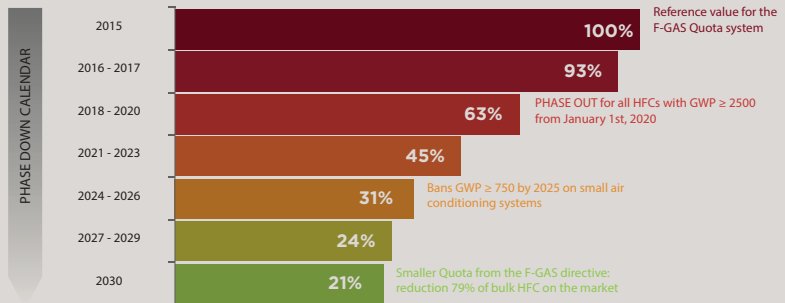

REFRIGERANT SAFETY CLASS: R32

A2L refrigerants have a low burning velocity and a low heat of combustion. These characteristics makes them hard to ignite and eliminates the risk of an explosion.

The European standard EN378 classifies R32 as an A2 refrigerant, while ASHRAE Standard 34 classifies it as an A2L. Both regulations define R32 as a mildly flammable gas. However, it is unlikely to start the fire, as a large amount of refrigerant is required to sustain combustion.

A1 eCOMFORT R410a	B1	No flame propagation
A2L eCOMFORT R32	B2L	Lower flammability
A2	B2	Lower flammability
A3	B3	Higher flammability
Higher toxicity	Higher toxicity	

BENEFITS OF R32

Low charge refrigerant:

- Up to 30% charge reduction on the total thermodynamic circuit

Single component substance:

- No glide
- Easy to handle and recover

Availability:

- Largely applied on the residential market
- Low price and easy to source

ASHRAE safety group: A2L

Composition:

- 100% Difluoromethane (HFC)

CO<sub>2</sub>e : CARBON DIOXIDE EQUIVALENT

CO<sub>2</sub>e indicates the amount of CO<sub>2</sub> which would have the equivalent global warming impact of any refrigerant.

To limit the use of high GWP refrigerants, many countries have set taxes to be applied on the sale those substances.

The tax is usually proportional to the CO<sub>2</sub>e and to the amount of fluorinated refrigerant used on the system (HFCs).

**CO<sub>2</sub>e = Refrigerant charge (kg) x GWP**

---

1000

**FRENCH FARES**

Step 1: 15€/CO<sub>2</sub>e

Step 2: 30€/CO<sub>2</sub>e

ADDITIONAL REFRIGERANT CHARGES

To exemplify one of the benefits of the eCOMFORT over its previous version (eCOMFORT R410/Ecolean), a comparison between two models with similar capacity presents 74% of savings on the additional refrigerant charges along the unit lifespan.

UNIT	"Neosys R410a NAC 300"	"eCOMFORT R32 GAC 300"
Refrigerant	R410a	R32
GWP <sup>1</sup>	1924	677
Refrigerant Price <sup>2</sup> (€/kg)	38 €	15 €
Leakage Charge per year <sup>3</sup> (kg)	1.85	1.1
Leakage Charge / 10 years (kg)	18.5	11
Refrigerant Cost (€/10years)	703 €	165 €
Leaked charge during step 1	7.4	4.4
CO2e	14.2	3.0
French taxes step 1	214 €	45 €
Leaked charge during step 2	11.1	6.6
CO2e	21.4	4.5
French taxes step 2	641 €	134 €
<b>TOTAL COST</b>	<b>1,557 €</b>	<b>344 €</b>

- 1. GWP values based on the IPCC 5th assessment report
- 2. Average price for French market (2019)
- 3. Considering average leakage rate of 5% per year

**78% OF SAVINGS**

LEAK TEST FREQUENCY

According to F-Gas, the amount of CO2e of the total refrigerant charge on a circuit will define how often a leakage test will be required.

A leak test usually takes a technician half day of work on the job site and may cost around 450€/test<sup>1</sup>.

Considering the same units from the previous example, the eCOMFORT can offer 50% of savings on the leak test costs along the unit lifespan.

CO2e	F-GAS LEAK CHECKING FREQUENCY	
	With no leak detection equipment fitted	With leak detection equipment fitted
CO2e ≤ 5	None	None
5 < CO2e ≤ 50	once every 12 months	once every 24 months
50 < CO2e ≤ 500	once every 6 months	once every 12 months
CO2e ≥ 500	once every 3 months	once every 6 months

UNIT	"Neosys R410a NAC 300"	"eCOMFORT R32 GAC 300"
Refrigerant	R410a	R32
GWP <sup>2</sup>	1924	677
Refrigerant Charge per circuit (kg)	18.5/18.5	11/11
CO2e per circuit	35.6/35.6	7.4/7.4
Leak detection equipment	-	Optional featured
Leak test frequency on each circuit	Once every 12 months	Once every 24 months
Leak tests along 10 years of lifespan	20 (10 on each circuit)	10 (5 on each circuit)
Leak test cost (€/test) <sup>1</sup>	450€/test	450€/test
<b>TOTAL COST</b>	<b>€ 9,000</b>	<b>€ 4,500</b>

- 1. The leakage test cost may diverge by region
- 2. GWP values based on the IPCC 5th assessment report

**50% OF SAVINGS**

**G**<sub>(A)</sub> **A**<sub>(B)</sub> **C**<sub>(C)</sub> **220**<sub>(D)</sub> **D**<sub>(E)</sub> **P**<sub>(F)</sub> **2**<sub>(G)</sub> **M**<sub>(H)</sub>

- (A) **G** = eCOMFORT
- (B) **A** = Air cooled unit
- (C) **C** = Cooling only unit - **H** = Heat Pump unit
- (D) **220** = Approximate capacity in kW
- (E) **D** = Double circuit
- (F) **P** = Refrigerant R32
- (G) **2** = Revision number
- (H) **M** = 400V/3/50Hz

KEY FEATURES

- Fast and easy installation and commissioning thanks to the integration of a complete hydraulic module with buffer tank and immersed heating rods.
- Excellent seasonal energy efficiencies (SEER) that exceed the European EcoDesign 2021 requirements.
- Precise water temperature control in cooling mode thanks to highly efficient components

ECODESIGN 2021



**eDrive**

Variable speed pump allowing capacity modulation.



**Desuperheater**

Free hot water production for sanitary or industrial purposes.



**Highly efficiency compressors**

Multi-scroll compressors, mounted in tandem or trio, allowing capacity modulation.

## RANGE PRESENTATION

### STRAIGHTFORWARD INSTALLATION

Installation and commissioning are fast and easy since the following features are integrated in the unit:



Complete hydraulic module with low or high-pressure single or twin pump, comprising pump(s), expansion tank with pressure gage and safety valve, pressure taps, water filter with sieve, air bleed and water flow controller.



Large-capacity buffer tank (500 and 1000 litres of water depending on the size of the unit), providing sizable energy storage and a buffer effect across the entire range.



Immersion heating rods, medium or high-power modulating auxiliary electric heating elements incorporated directly in a buffer tank inside the unit.

Only electric and hydraulic connections are required for the eCOMFORT unit.

### USER COMFORT THROUGHOUT THE YEAR

With extended operating ranges, the eCOMFORT range has been designed to guarantee thermal comfort throughout the year.

- In heating mode, the eCOMFORT range produces hot water at 42°C up to an outdoor temperature of -10°C: thermal comfort is maintained throughout the winter. Furthermore, the unit works in extreme cold, right down to -15°C, and the heating rods ensure thermal comfort is always maintained and guaranteed. Medium- or high-power modulating auxiliary electric heating elements are incorporated in a buffer tank inside the unit.
- In cooling mode, the unit works at full load from -20°C to 46°C ambient air. In addition, it can work at partial load up to ambiances reaching 52°C. For industrial applications, the outlet water temperature can go as low as -12°C.
- The eCOMFORT units offer precise control of the outlet water temperature in cooling and heating modes thanks to multistage scroll compressors in conjunction with an electronic expansion valve and a large-capacity buffer tank. In addition, this water tank ensures sizable energy storage. Its buffer effect eliminates the constraints of high variable load systems and the inconvenience associated with the defrost phases for heat pumps.

### ACOUSTIC COMFORT

The eCOMFORT range has different noise levels, meeting all external constraints.

- Quiet operation as standard thanks to the use of high performance bionic owl profiled blades and high performance composite housing with air diffusor for a maximum air flow and acoustic efficiency.
- Second effective noise level with integration of the optional, high-performance acoustic enclosure, dividing by four the noise of the unit (-6 dBA).
- Intelligent noise attenuation system called "Active Acoustic Attenuation System". Combined with the optional variable air flow controller (EC fan – standard on Heat pump models), this system automatically adjusts the air flow to remain within the daytime and nighttime noise level constraints (programmable) while guaranteeing thermal comfort in the building. The noise level of the unit can be divided by eight (-9 dBA).



## CONNECTIVITY FOR COMFORT

LennoxHydrocontrol is a user-friendly interface for local supervision of the entire hydraulic system. It guarantees constant comfort throughout the year and saves energy thanks to:

- zoning of the building,
- time programming by zone,
- precise control of setpoints by zone,

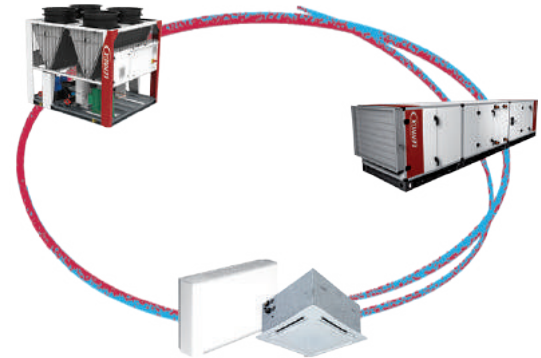

## CONNECTIVITY FOR PERFORMANCE

LennoxCloud facilitates remote monitoring of the unit, making it possible to achieve significant energy savings while avoiding performance drifts throughout the unit's life cycle. The eComfort units can be remotely controlled, adjusted and diagnosed:

- through online verification of all unit data trends,
- through optimization of unit operation by analysing this data,
- by facilitating maintenance thanks to alarm and alert reports.

Also, LennoxCloud is a single system able to supervise several units located on different installations.



1. QUIET++ MODE: The unit operating limits are reduced (around 42°C of max outside air temp.)

## TECHNICAL DESCRIPTION

### CONSTRUCTION OF THE UNIT, CASING AND BASE FRAME

The eCOMFORT range complies with the standards and directives of the European Community.

All the eCOMFORT units are designed and manufactured according to an ISO 9001 quality and ISO 14001 environmental management system.

The casing and the base frame are in painted or pre-lacquered galvanized steel, guaranteeing high corrosion resistance. The casing is white in color (RAL 9003) with red uprights (RAL3003) and the base frame is gray (RAL7016).

### COMPRESSORS

The units are equipped with R32 compatible multi-scroll compressors, mounted in tandem or trio, to provide the best seasonal efficiencies ( $\eta_{s,c}/SEER$ , and SEPR) and acoustic noise level.

The scroll compressors are of simple and robust design, thus increasing their reliability and service life thanks to:

- Axial and radial play, which allows the compressor to tolerate the liquid slugging,
- Motor winding cooled by the gas intake,
- Electronic control of the compressor discharge temperature,
- A device to protect the motor against overcurrent and overheating, based on size,
- A non-return valve on the discharge,
- An oil equalization sight glass,
- Mounting on an independent base frame insulated by anti-vibration pads.



### WATER HEAT EXCHANGER

The evaporator on the eCOMFORT unit is of the latest generation of heat exchangers made from stainless steel plates with copper brazing.

These exchangers improve the seasonal efficiencies and reduce internal pressure drops.

They are thermally insulated and frost-protected:

- either through the use of glycol,
- or through activation of the pump managed by the control system,
- or through optional electric tracing.

### AIR HEAT EXCHANGER

As standard, the eCOMFORT cooling only water chillers are equipped with all-aluminum microchannel condenser coils which provide:

- a significant improvement in efficiency,
- a 60% reduction in the amount of refrigerant required,
- better corrosion resistance, especially in moderate urban or coastal environments.

The eCOMFORT heat pumps are themselves equipped with traditional conser coils made from copper tubing and aluminium fins.

All coils may have an optional anti-corrosion treatment for resistance against highly aggressive environments.

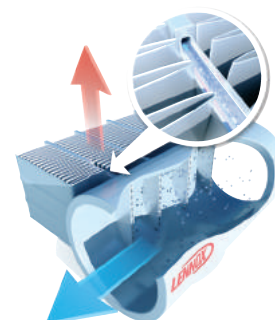

### FANS

As standard, the unit is equipped with latest-generation, high performance propeller fans with profiled blades. The aerodynamic shape of the blades is optimized, reducing the noise level considerably while significantly increasing the efficiency compared to conventional blades. These high-performance propeller fans are equipped with EC (electronic commutation) technology, allowing the variable air flow rate to be controlled.

As an option, these high-performance propeller fans can be equipped with AC (alternating current) technology.

All the electric fan motors are class F and are protected against overheating by internal thermal protection as well as IP55 protection.



### REFRIGERATION CIRCUIT

The eCOMFORT range has 2 independent refrigeration circuits using R32 refrigerant.

Each refrigeration circuit includes:

- the required amount of refrigerant, which is 60% less thanks to the use of R32 refrigerant and microchannel heat exchangers
- a dehydration filter with filter cartridge,
- an electronic expansion valve
- temperature and pressure sensors,
- a high-pressure safety switch.



Each sealed refrigeration circuit is nitrogen-brazed and fitted by certified operators.

Before evacuation and refilling with refrigerant, each refrigeration circuit undergoes a pressure tightness test using a nitrogen/ hydrogen mixture and a leak detection procedure. All the units are then subjected to full electrical and functional tests and trials to ensure and guarantee they are perfectly sealed and functioning properly before dispatch.

### ELECTRICAL CABINET

- Electrical cabinet, components and cabling compliant with the EN 60204-1 standard.
- 400 V three-phase power supply, 50 Hz, + earth without neutral.
- Power cable inlet is in the lower part of the cabinet.
- IP54 tightness class.
- Electric components are of an international brand to facilitate maintenance and ensure fast replacement.
- Main on/off switch mounted on the front.
- Customer display accessible on the front.
- 400/24 V transformer for control circuit power supply.
- Electrical cables numbered to facilitate maintenance and diagnostic operations.
- Electrical cabinet ventilation provided by a fan.

### REGULATION

The eCOMFORT range is equipped with the latest generation eCLIMATIC controller.

The eCLIMATIC control system is designed to offer the best seasonal energy efficiencies throughout the unit's service life while ensuring reliable operation, with user-friendly interfaces.



This control system offers numerous possibilities. The main functions are as follows:

- 7 programmable time periods a day, 7 days a week, making it possible to manage the energy savings and the noise level according to the environmental constraints and the constraints on usage of the premises. There are 4 operating modes to choose from,
- Dynamic management of the setpoints: water logic based on outdoor temperature. This control system automatically adjusts the outlet water temperature setpoint based on the cooling (floating LP) or heating requirement and the outdoor temperature,
- Controlling the variable-speed pumps with maintenance of constant delta P, constant delta T or fixed speed/dead zone control, guaranteeing a reduction in the annual energy consumption related to pumping,
- Control of the bypass valve (if this option is chosen) in constant delta P regulation,
- Intelligent management of the noise level by controlling the variable air flow of the fans,
- Management of compressor and pump run-time balancing and automatic changeover in the event of a pump fault (if twin pump option is chosen),
- Automatic unloading of a compressor in case of excessive condensation pressure, allowing the machine to operate even when outside air temperature is high, (operation up to 52°C ambiance in partial load),
- Control and protection of all operating ranges,
- Management and regulation of several master/slave units (cascade, takeover).

The eCLIMATIC control system offers an interface on the front, the "DC Advanced" display, equipped with a graphic screen providing access to the main user parameters:

- Reading the variables: temperatures of ambient air, water and refrigerant,
- Reading the refrigerant pressures,
- Reading and programming the operating times and modes,
- Reading and programming the water temperature setpoints,
- Reading and programming the noise level setpoints,
- Alarm history.



### COMMUNICATION

The eCLIMATIC control system is equipped as standard with a GTC port enabling remote control via a communication bus. Depending on the desired communication protocol, the eCLIMATIC control system can be equipped with an optional ModBUS® or BacNET® communication card.

The control system allows remote control of the unit as standard via programmable dry contacts (2 inputs/1 output).

These dry contacts are by default:

- One input: on/off,
- Another configurable input (e.g. summer/winter changeover),
- An output for alarm reports or information.

### STANDARDS: OVERVIEW

- The unit is manufactured in compliance with the European standards and directives:
- 2014/68/EU Pressure Equipment Directive
- 2006/42/CE Machinery Directive
- 2014/35/EU Low Voltage Directive
- 2014/30/EU Electro Magnetic Compatibility Directive
- EN378-2016 - Refrigerating systems and heat pumps - Safety and environmental requirements
- 2011/65/EU The European Restriction of the Use of Certain Hazardous Substances (RoHS)
- « WEEE », 2012/19/EU – Directive on waste electrical and electronic equipment
- 2009/125/EC Ecodesign (UE2016/2281 and UE2015/1095 for cooling only and UE 813/2013 for heating)
- EN-60204-1.

LENNOX CLOUD

Lennox cloud is the best tool to remotely monitor and manage all your rooftop and chiller units, independent of their location and condition.

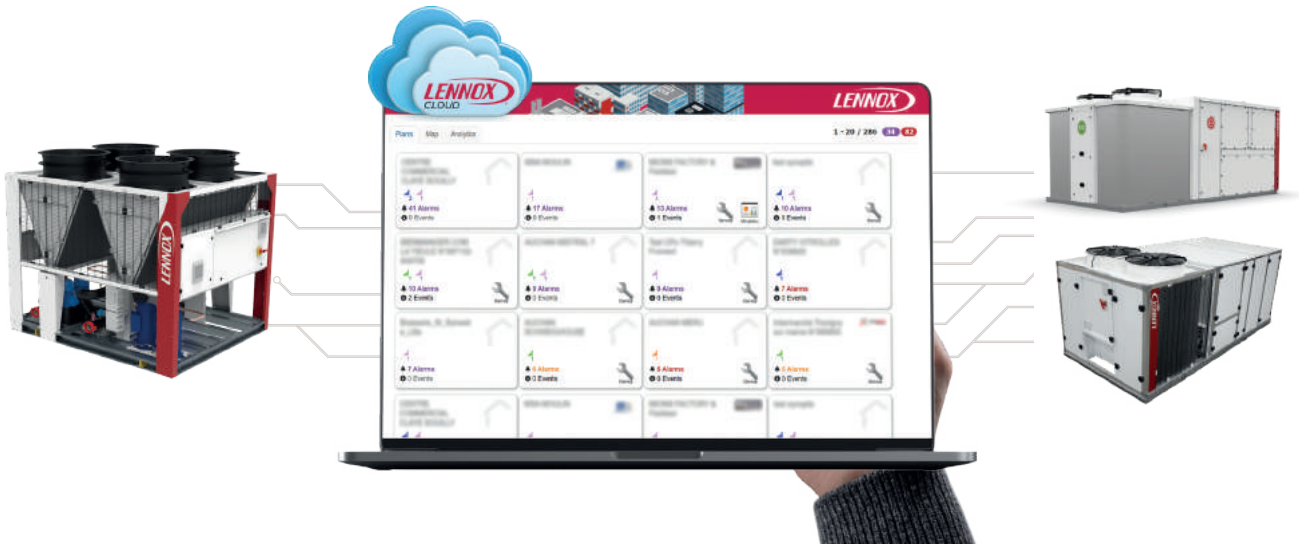

It allows you to monitor and control all units on the same place, from any web browser. Remotely adjust set points from any installation site through a friendly and self-explanatory layout. Lennox Cloud grants you access to alarm history and dashboards with real-time system performance and energy consumption<sup>1</sup> from the entire installation site or from individual units.

WEBVIEW

Remote adjust of system setpoints:

1. Inlet water temperature;
2. Outlet water temperature;
3. Alarm indication;
4. System ON or OFF button;
5. External temperature;
6. Adjust set points;
7. Adjust settings;
8. Adjust time schedule;
9. System mode status:

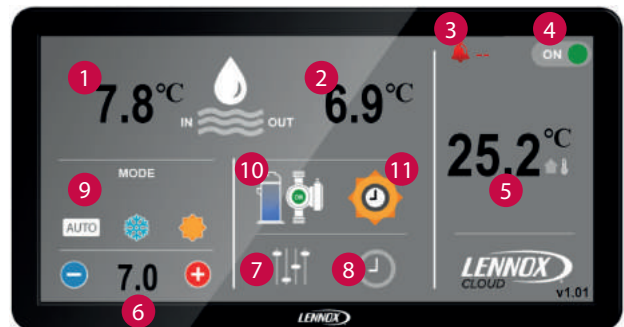

AUTO

Auto mode

Lock:  
Only cool

Lock:  
Only heat

10. Compressor and pump

Pump off

Pump off Heat

Pump off Cool

Pump on

Pump on Heat

Pump on Cool

11. Time schedule status

BMS mode (building management system)

Day 2 mode

Day 1 mode

Daytime operation

Night operation

1. Require Electric Energy Meter - optional feature

LNCJ	Low noise: rigid accoustic compressors enclosure
SFAC	Fix speed standard AC fans (Standard on Cooling only models)
ACTR	LenGuard anti-corrosion condenser coil treatment
CPGR	Coils protection : metallic grille
FCPG	Full metallic grelle pack
VGUA	Aesthetic pack
LLWT	Low leaving water temperature down to -12°C
PHRF	Hot sanitary water supply : desuperheater
FZPH	Antifreeze protection on desuperheaters and pipings
RLKD	Refrigerant leak detection
SYRP	Insulation of refrigeration suction piping
FRE1	One V free cooling
FRE2	Two V free cooling
SPLP	Hydraulic module with low-pressure single pump
DPLP	Hydraulic module with low-pressure twin pump
SPEL	Hydraulic module with eDrive low-pressure single pump
DPEL	Hydraulic module with eDrive low-pressure twin pump
SPHP	Hydraulic module with high-pressure single pump
DPHP	Hydraulic module with high-pressure twin pump
SPEH	Hydraulic module with eDrive high-pressure single pump
DPEH	Hydraulic module with eDrive high-pressure twin pump
BYVC	Bypass Valve for delta P control with eDrive pump (supplied loose)
EXTA	Expansion Tank
WTNG	Water tank
WTNH	Water tank 1000L

WTHS	Water tank electrical heater Standard
WTHH	Water tank electrical heater High
WFIF	Water filter (supplied loose)
KGRL	Flange connection (supplied loose)
APEP	Antifreeze protection on exchangers and pipings down to -20°C
APPP	Antifreeze protection on exchangers, pipings,pump(s) down to -20°C
APPW	Antifreeze protection on exchangers, pump(s) piping and water tank down to -20°C
CGSM	Lennox Cloud conectivity GSM communication
CETH	Lennox Cloud connectivity Ethernet communication
BNET	BACnet® interface MSTP
MBUS	ModBus interface RS485
MBIP	ModBus and BACnet® interface TCP/IP
DM60	Remote advanced display (supplied loose)
DS60	Service display (supplied loose)
DCBO	Remote control: customer drive contact input/output
CTBK	Circuit breaker
EEEM	Efficiency energy meter
ELME	Electric energy meter
PHCT	Phase reversal protection
POWF	Power factor correction
SOFT	Soft starter
AVUB	Anti-vibration mounts rubber type (supplied loose)
SLCR	Wooden crate for long distance
CLOA	Container loading

**ACOUSTIC OPTION**

**LOW NOISE LEVEL OPTION (CODE LNCJ)**

For noise-sensitive environments and areas, the compressors are equipped with a high-performance acoustic enclosure allowing **the noise level to be reduced reduced by 6db(A) in average without any reduction in performance.**



**OPTIONS FOR FAN AND EXTERNAL COILS**

**STANDARD VARIABLE AIR FLOW CONTROL BY EC FAN**

The standard variable air flow control by EC fan offers the following advantages comparing to the option fix speed AC fan (SFAC):

- Year-round operation down to -20 °C outdoor temperature in cooling mode.
- Year-round operation up to 30 °C outdoor temperature in heating mode (heat pump).
- A further increase in energy savings through improved seasonal efficiencies (floating HP).
- Intelligent noise attenuation management, programmable night and day, combined with acoustic covers.
- Available static pressure up to 210/250 Pa for encased and indoor applications (fan curves on page 30).



Option code	Type	Available static pressure
Standard	Standard EC fan	up to 170 Pa
SFAC	Standard AC fan	0 Pa

**FLOATING HIGH PRESSURE IN COOL MODE**

LENNOX optimizes the performance of its eCOMFORT units in cool mode by using EC fans , allowing maximum savings to be achieved.

We determine an optimal correlation between the condensation temperature and the outside air temperature, which allows us to obtain the lowest possible consumption for the compressors/condenser fan motors.

**ANTI-CORROSION PROTECTION: LENGUARD (CODE ACTR)**

For installations in potentially aggressive environments such as coastal or industrial areas, LENNOX offers the option of non-toxic, water-based anti-corrosion protection treatment for condensers, validated over 10,000 hours of salt spray testing (ASTM B117 standard)

**METALLIC GRILLE ON THE TOP : COIL PROTECTION (CODE CPGR)**

Black metal protection grilles are mounted on the top of the unit. They guarantee the protection of the coils and copper piping by avoiding shocks, cuts and burns.

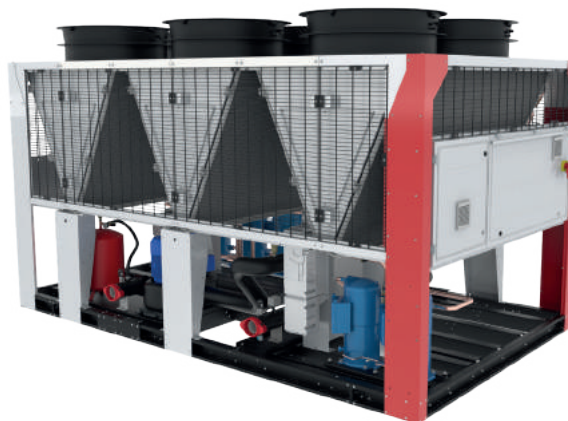

**FULL METALLIC GRILLE PACK (CODE FCPG)**

Black metal protection grilles are mounted on the top and bottom of the unit. They guarantee the protection of the unit by avoiding shocks, cuts, burns and acts of vandalism.

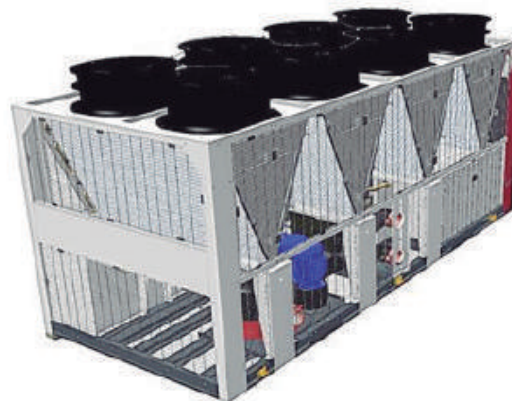

**AESTHETIC PACK (CODE VGUA)**

White metal panels are installed on the top and on each side of the unit. They improve the aesthetic of the unit and protect the condenser piping avoiding shocks and burns.



**DESUPERHEATER: HOT WATER FOR SANITARY PURPOSES (OPTION ONLY AVAILABLE FOR COOLING ONLY MODELS CODE PHRF)**

On eCOMFORT units, a plate heat exchanger on each refrigeration circuit enables production of hot water up to 70°C. Heat recovery is greater than 20% of the rejected heat depending on the temperatures required. A single inlet and outlet hydraulic are available to connect to the network for simplicity of installation.

**ANTIFREEZE PROTECTION ON DESUPERHEATERS AND PIPING (OPTION ONLY AVAILABLE FOR COOLING ONLY MODELS CODE FZPH)**

Thermal insulation and electrical heat tracing of the plate heat exchangers and piping to protect against frost to -20°C ambient temperature if no glycol.

**REFRIGERANT LEAK DETECTION (CODE RLKD)**

Refrigerant leak detection prevents performance and efficiency degradation as well as unwanted downtime and extends maintenance intervals in terms of leak checking.

Refrigerant leak detection allows the customer to check, via the temperature and pressure sensors in the refrigeration circuit, whether the amount of refrigerant varies during the life cycle of the unit.

Via the eClimatic controller, these sensors provide the customer with information about the status of the refrigeration circuit.

**INSULATION OF REFRIGERATION SUCTION PIPING (CODE SYRP)**

This option includes the isolation of the refrigerant suction pipes from the compressors to the evaporator.

**FREE COOLING**

Free Cooling is divided in Two options :

**FRE1** : One V free cooling (Additional free cooling coils with inverter fans and modulating valves to cool the chilled water)

**FRE2** : Two V free cooling (Additional free cooling coils with inverter fans and modulating valves to cool the chilled water)

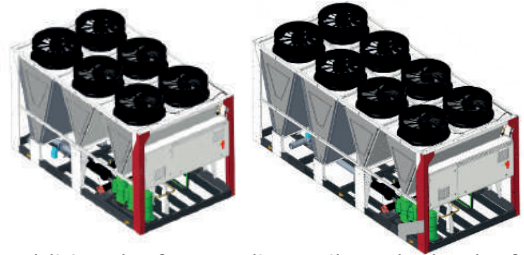

Compared with the basic configuration this option features one or two additional V free cooling coils at the back of the unit. The free cooling includes two motorised valves, allowing the chilled water to run through the free-cooling coils, which uses less power and utilises the lower ambient air to cool the water. The cooling capacity of one V free cooling coil at 0°C ambient is approximately 100 kW. eComfort free cooling system is using the same fans and speed inverters as for the standard unit in order to keep the same acoustic capabilities. The hydraulic module options are compatible with the Free Cooling option but glycol is of course required.

Typical free cooling applications can be facilities with cooling demand all along the year, such as offices with high internal loads like computer rooms, data centers, etc. In the North and North-East part of Europe, the ambient temperature is below 5°C between 20 and 45% of the year that makes this option very attractive.

**CONTROL PRINCIPLE**

The control principle is the following: if ambient Temperature < return Temperature - 3°C, motorised valves open to by-pass return water flow through the Free Cooling coils. The Free Cooling fans are driven by the eCLIMATIC 0 via a specific PID algorithm. The Free cooling operation is considered as a cooling stage that has a priority on the compressor stages: only if the free cooling fan speed has reached the maximum fan speed then the compressors are allowed to run with their own PID.

**ADVANTAGES OF THE ECOMFORT FREE COOLING SYSTEM**

- Simultaneous compressor cooling capability to reach building needs in any conditions (vs. DX free cooling that can not operate simultaneous compressor and free cooling).
- Design with additional V free cooling coils to eliminate unnecessary air pressure drop when running 100% in compressor cooling mode thus reducing all along the year energy fan consumption (vs. traditional free cooling system with free cooling coils located in series with the condensing coil.)
- Free cooling as soon as the air outside is cold enough (3°C below return water temperature).
- Reduce the running use of the compressors.
- Extend the life expectancy of the compressors.
- Reduce power costs.
- Payback could be as little as 12 months

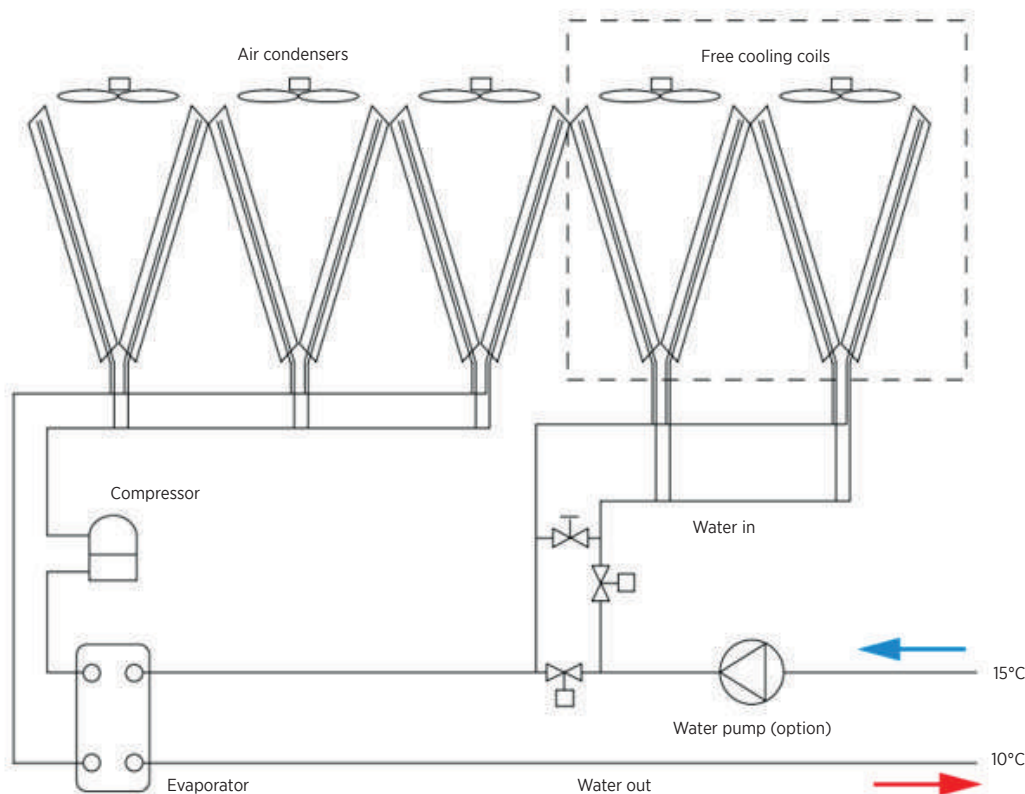

**HYDRAULIC OPTIONS:**

**Hydraulic module:**

The hydraulic module is integrated in the eCOMFORT unit. It is composed of one or two pumps and all the hydraulic equipment required for **fast commissioning** on-site:

- single pump or twin pumps,
- vane-type water flow controller,
- expansion tank,
- pressure gage,
- drain valve,
- water temperature sensor,
- safety valve,
- air bleed,
- pressure tap,
- water pressure sensor with eDrive option.



Numerous hydraulic modules are available depending on the type of pump and static pressure requirement:

Option code	Type of pump	Available static pressure up to
SPLP	One single pump	150 kPa
DPLP	Two single pumps	
SPEL	One single pump with a speed variator (eDrive)	50 to 150 kPa
DPEL	Two single pumps with a speed variator (eDrive)	
SPHP	One single pump	230 kPa
DPHP	Two single pumps	
SPEH	One single pump with a speed variator (eDrive)	150 to 230 kPa
DPEH	Two single pumps with a speed variator (eDrive)	

The twin pumps are in normal/emergency operation.

The hydraulic modules with speed variator (eDrive) adapt to requirements from 50 to 230 kPa. Numerous control modes are available, **enabling significant savings on installation and energy consumption** as well as rapid returns on investment.  
Please refer to the corresponding chapter on variable water flow.

**HYDRAULIC OPTIONS (CONT.):**

**BYPASS VALVE FOR ΔP CONTROL WITH VARIABLE SPEED PUMP (EDRIVE) (CODE BYVC)**

The bypass valve controlled by the unit is essential on variable water flow systems regulated in constant ΔP and with terminals equipped with 2-way valves.

This configuration ensures the best energy savings on the installation and the energy costs of operating the pump.

Please refer to the corresponding chapter on variable water flow.

The bypass valve is supplied not mounted on the unit.

Cooling Only models			
By-pass valve information	220D	250D→370D	400D
Connection diameter	DN65	DN80	DN100
Connection type	Flanged PN16		

Heat Pump models			
By-pass valve information	220D	250→370D	400D→450D
Connection diameter	DN65	DN80	DN100
Connection type	Flanged PN16		

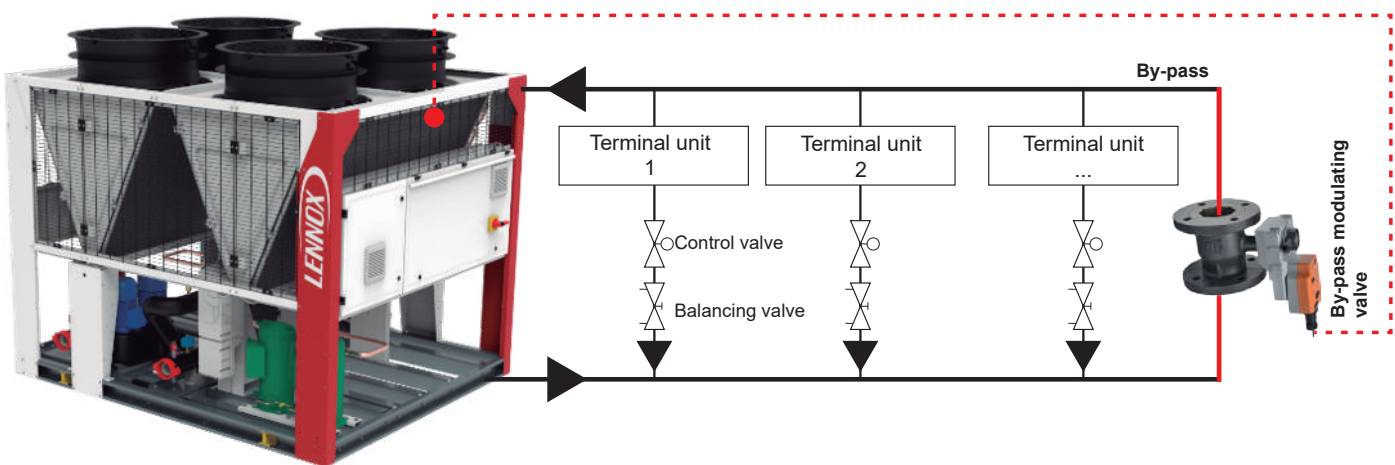

**EXPANSION TANK (CODE EXTA)**

Expansion Tank (code EXTA)

A 50 liters expansion tank is available to allow the variation of the volume of water depending on the temperature variation of the water. The maximum water contents of the installation with this expansion vessel are available in the documentation (IOM).

**BUFFER TANK (CODE WTNG AND WTNH)**

The buffer tank is a an essential option in the case of a water loop of low volume or with fast variable thermal load.

This tank is placed on the water return and **ensures sizable energy storage as well as a buffer effect** with:

- Precision and stability in the outlet water temperature,
- Inertia on water return, avoiding untimely operation and thus short cycles unacceptable for the compressors = reliability,
- Elimination of the discomfort associated with the defrost cycles on the heat pumps.

Two options are available:

- WTNG - 500L water tank available for all units
- WTNH - 1000L water tank available for all units with capacity higher than 260kW on heat pump and higher than 300kW on cooling models

**MODULATING ELECTRIC HEATING ELEMENTS (ON HEAT PUMP ONLY):**

In extreme cold, auxiliary modulating electric heating elements **ensure thermal comfort is maintained**. They are integrated in the unit, directly in the buffer tank.

High-power auxiliary modulating electric heating elements are also available **to guarantee and secure thermal comfort** should a thermodynamic circuit fail.

Power of electric heating elements:

Option Code	Type	Unit equipped with	
		WTNG	WTNH
WTHS	Standard electrical power	36kW	72kW
WTHH	Higher electrical power	72kW	108kW

**WATER FILTER (CODE WFIF)**

A “Y” filter with stainless steel sieve (filtration diameter: 1 mm) is available with PN16 flange. In this case, flange connections option are mandatory for mounting the filter on the unit.

This protection must be mounted on the customer’s supply piping in order to protect the evaporator from all possible impurities. The filter is supplied not mounted on the unit.

This protection must be mounted on the customer’s supply piping in order to protect the evaporator from all possible impurities. The filter is supplied not mounted on the unit.

**FLANGE CONNECTION: (CODE KGRL)**

Two connection sleeves with Victaulic groove on one side and flange on the opposite side are available. The connections are supplied not mounted on the unit.



**FROST PROTECTION (CODE APEP, APPP OR APPW)**

On water chillers and heat pumps, if the water is not glycolated, frost protection down to -20 °C outdoor temperature is available:

- electric tracing of plate exchanger and pipes,
- electric heating elements included in the buffer tank.

Electric power of frost-protection heating elements in tank.

		Cooling only unit Size	
		220D to 300D	330D to 400D
Electrical power		9.4 kW	12.4kW

		Heat Pump unit Size	
		220D to 250D	280D to 450D
Electrical power		9.4 kW	12.4kW

**CONTROL AND COMMUNICATION**

**LONWORKS FTT10 COMMUNICATION INTERFACE (CODE ECLO)**

This card is a LonWorks interface, required for any connection between a GTC system with Lon protocol. One card per machine is required.

The list of variables can be found in the eClimatic controller manual.

**BACNET MSTP COMMUNICATION INTERFACE (CODE BNET)**

This card is a communication interface that uses the BACnet® protocol and enables communication with a BACnet MSTP system. This card is essential for any connection between the unit and a LennoxHydrocontrol system.

The list of variables can be found in the eClimatic manual

**MODBUS RS485 COMMUNICATION INTERFACE (CODE MBUS)**

This card is a communication interface that uses the Modbus protocol and enables communication with a Modbus RS485 system.

The list of variables can be found in the eClimatic manual.

**MODBUS OR BACNET TCP/IP COMMUNICATION INTERFACE (CODE EWFS)**

This card is a communication interface that uses the Modbus/BACnet TCP/IP protocol and enables communication with an IP network.

The list of variables can be found in the eClimatic manual.

**REMOTE DISPLAY (CODE DM60)**

The optional “DM Multi” remote display has the same design and the same advanced functions as the “DC Advanced” display on the front. It offers the following additional functions:

- remote connection up to 500 m,
- wall mounting,
- ability to manage up to 8 units with a single display, the units must be connected to the master/slave bus.



**SERVICE DISPLAY (CODE DS60)**

The “DS Service” service display, specifically for the experts, allows the technical service or maintenance personnel to adjust, read and modify all parameters of the unit.

**REMOTE CONTROL: ADDITIONAL CLIENT INPUTS/OUTPUTS (CODE DCBO)**

An expansion card is available with 10 universal inputs (NTC, 4/20mA, TOR dry contact) and 6 additional logic outputs.

Each input/output can be parameterized to **allow remote control of the installation.**



## ELECTRIC OPTIONS

### EFFICIENCY ENERGY METER (CODE EEEM)

Measurement and monitoring of the instant energy efficiency of the unit is available by combining the instant thermal energy and instant electrical energy measurement. The energy efficiency of the unit depends on the climate and its application. The tracking of energy efficiency makes it possible to compare its evolution (month / season / year) and to anticipate any drift in performance. The reading of the instant energy efficiency is available on the display and reportable by BMS or LennoxCloud (connectivity).



### ELECTRICAL ENERGY METER (CODE ELME)

Current transformers (TI) are placed on the customer's power supply cables. They convert the main current into a secondary current (0 to 5 A) sent to an energy meter. The energy meter communicates the following values to the eClimatic system:

- active power at the time t in kW,
- power factor (cos phi),
- total active energy meter in kWh.

These values are displayed on the energy meter and forwarded to the display on the front as well as the remote and service displays.

They can be forwarded to a GTC via Modbus or BACnet (RS485 or TCP/IP) and made available on our LennoxCloud remote monitoring system.

### PHASE PROTECTION (CODE PHCT)

The phase controller is recommended when the power supply is unreliable or unstable, or when using an emergency generator. It **protects the components of the unit** against overvoltage, undervoltage or phase failure (phase reversal or loss).



### POWER FACTOR CORRECTION (CODE POWF)

On eCOMFORT units from 90 to 210 kW, power factor correction improves the electrical efficiency of the unit. The module compensates the phase angle (Cos Phi) between the voltage and the current by using capacitors and thus **helps reduce electrical energy consumption**.

### COMPRESSOR SOFT START (CODE SOFT)

With compressor soft start, the starter reduces the stresses on the installation:

- **Reduction of installation cost** by reducing the size of the upstream transformer,
- Reduction of loads in electrical distribution, current spikes down to -40% and drops in voltages related to engine start-ups,
- **Reduction of machine operating costs** by reducing the mechanical stresses,
- Automatic adaptation to network frequency,
- Protection against transient or permanent underload and overcurrent.



### CIRCUIT BREAKER (CODE CTBK)

The standard units come equipped with fuses to protect the compressors. This option integrates circuit breakers for optimal protection of your unit.

### ADAPTER FOR POWER SUPPLY WITH ALUMINUM CABLES (CODE ALWA)

A special adapter kit is available for connecting the unit with aluminum cables. This kit is supplied not mounted on the unit.

### ANTI-VIBRATION MOUNTS (CODE AVUB)

These rubber anti-vibration mounts reduce the transmission of vibrations to the ground and the noise level in general. They are fixed underneath the unit at the points specified in the installation manual. They are supplied not mounted.

### PROTECTION FOR LONG-DISTANCE TRANSPORT (CODE SLCR)

The entire unit can be packaged in a slatted crate for protection during very long distance transport by truck or container.

### CONTAINER LOADING ( CODE CLOA)

This option contains a kit to the unit loading and unloading the unit by containers

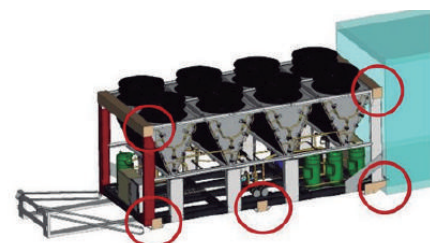

# GENERAL DATA

## STANDARD COOLING ONLY UNIT

eCOMFORT - GAC		F BOX			G BOX			
		220D	250D	300D	330D	370D	400D	
<b>Cooling mode</b>								
Cooling capacity :		kW	178.0	200.2	213.5	264.6	298.4	332.2
Total absorbed power <sup>(1)</sup>			53.4	64.3	70.5	85.0	101.5	106.6
EER <sup>(3)</sup>		3.3	3.1	3.0	3.1	2.9	3.1	
Comfort applica-tion	Seasonal Energy Efficiency Ratio <sup>(3)</sup> SEER	5.0	4.9	4.9	4.9	4.9	4.8	
	Seasonal energy efficiency <sup>(4)</sup> $\eta_{s,c}$	196.3	192.7	191.3	193.6	194	190.9	
Process applica-tions	Seasonal Energy Process Ratio (5) SEPR - High temperature (7°C)							
	Seasonal Energy Process Ratio (5) SEPR - High temperature (7°C)	5.4	5.3	5.3	5.3	5.4	5.2	
Comfort applica-tion	With AC fans	Seasonal Energy Efficiency Ratio (3) SEER	5.15	5.00	4.78	4.95	4.85	-
		Seasonal energy efficiency (4) $\eta_{s,c}$	203	197	188	195	191	-
Process applica-tions	With AC fans	Seasonal Energy Process Ratio (5) SEPR - High temperature (7°C)	6.33	6.24	6.03	6.46	6.16	-
		Seasonal Energy Process Ratio (6) SEPR - Medium temperature (-8°C)		-	-	-	-	-
<b>Refrigeration circuit</b>								
Number of circuits		2	2	2	2	2	2	
Refrigerant charge (circuit 1)		kg	9	10	11	12	12	16
Refrigerant charge (circuit 2)		kg	10	10	11	16	18	18
Refrigerant charge (total)		kg	19	20	22	28	30	34
Type of expansion valve		Electronic expansion valve						
<b>Compressor</b>								
Multi stage Scroll compressors								
Number of compressors		2+2			2+3			
Type		Tandem			Tandem / Trio			
Capacity steps		0-21-50-71-100 %	0-25-50-75-100 %	0-25-50-75-100 %	0-22-41-63-82-100 %	0-20-40-60-80-100 %	0-18-36-64-82-100 %	
Rotation Speed (RPM)		2900						
Oil type		BVC32						
Oil load		kg	2 x 2 x 3.6 + 2 x 1	2 x 2 x 6.1 + 2 x 2	2 x 2 x 6.1 + 2 x 2	2 x 6.1 + 3 x 6.1 + 2 + 5	2 x 6.1 + 3 x 6.1 + 2 + 5	2 x 6.1 + 3 x 6.1 + 2 + 5
<b>Condenseur</b>								
Aluminium tubes and fins								
Number of condensers		4	4	4	6	6	8	
<b>Condenseur fan</b>								
Axial fan								
Number of condenser fans		4	4	4	6	6	8	
Nominal airflow rate		m <sup>3</sup> /h	77768	90127	90127	110374	110374	135190
Rotation speed (rpm)		700 / 950	950 / 950	950 / 950	950 / 700	950 / 700	950 / 950	
<b>Evaporator</b>								
Braze plate heat exchanger								
Number of evaporators		1						
Nominal water flow rate		m <sup>3</sup> /h	36.88	43.12	50.45	56.36	62.48	69.96
Nominal pressure drop		kPa	29.97	30.44	39.31	48.63	54.77	65.93
Water volume		L	19.5	24.0	27.3	27.3	30.9	33.0
Hydraulic service pressure without hydraulic module		kPa	1000					
<b>Hydraulic module (option)</b>								
Type of pump Low or high pressure pump		Stainless steel centrifugal single or twin pump mounted in parallel						
Expansion vessel volume		L	50					
Hydraulic service pressure with pump(s)		kPa	1000					
Insulated water tank		L	500		500/1000			
Hydraulic service pressure with pump(s) and water tank		kPa	350					
<b>Hydraulic connections</b>								
Type of standard connection		Victaulic						
Inlet / Outlet connection diameters		4"						
Inlet / Outlet external diameters		mm	4"					
Type of optional connection		Flange DN 100						
<b>Electrical data</b>								
Power supply		400V / 3 / 50Hz + E						
Maximum power		kW	97.8	110.2	131	150.2	165.9	183.5
Maximum running current		A	329.1	331.2	397.4	428.3	454.6	612.6
Starting current		A	164.4	180.6	215.6	246.4	272.6	302.7
Short circuit capacity		kA	50					
Power factor			0,88	0,88	0,88	0,88	0,88	0,88
<b>Acoustic data</b>								
Global sound power level Standard unit		dB(A)	87.5	88	89.2	89.4	91.2	90.4
<b>Dimensions</b>								
Length			2772			4044		
Width		mm	2264					
Height with standard fan(s)			2421					
Operating weight		kg	1588	1690	1728	2243	2263	2334

(1) EUROVENT certified data, in accordance with standard EN 14511 :  
Cooling mode : Evaporator water temperature = 12/7°C / Outdoor air temperature = 35°C  
Heating mode : Condenser water temperature = 40/45°C / Outdoor air temperature = 7°C

(2) SEER in accordance with standard EN 14825.  
(3) Following ecodesign regulation EU 2016/2281 on space cooling, normalized leaving water temperature at 7°C, in accordance with standard EN 14825.

(4) Following ecodesign regulation EU 2016/2281 on process cooling units, normalized leaving water temperature at 7°C, in accordance with standard EN 14825.

(5) Following ecodesign regulation EU 2015/1095 on process cooling chillers, normalized leaving water temperature at -8°C, in accordance with standard EN 14825

# GENERAL DATA : STANDARD HEAT PUMP UNIT : STANDARD FANS AND STANDARD COMPRESSORS

eCOMFORT - GAH		B BOX		B+ BOX			C BOX					
		220D	250D	280D	300D	330D	370D	400D	450D			
<b>Cooling mode</b>												
Cooling capacity		kW		211.9	248.9	274.2	303.7	342.2	366	404.7	441	
Total absorbed power <sup>(1)</sup>		kW		69.7	81.7	86.3	99.3	112.6	117	130.1	143	
EER <sup>(2)</sup>				3.04	3.05	3.18	3.06	3.04	3.13	3.11	3.08	
Eurovent energy class <sup>(1)</sup> - Full load operation				A	B	A	B	B	A	A	B	
Comfort Application	Seasonal Energy Efficiency Ratio <sup>(2)</sup> <b>SEER</b>			5.05	4.9	4.95	4.98	4.95	5.35	5.33	5.18	
		Seasonal energy efficiency <sup>(3)</sup> <b>η<sub>s,c</sub></b>		199	193	195	196	195	211	210	204	
Process Application	Seasonal Energy Performance Ratio <sup>(4)</sup> <b>SEPR</b> - High temperature (7°C)			6.56	6.68	6.59	6.77	6.62	7	6.85	6.68	
		Seasonal Energy Performance Ratio <sup>(5)</sup> <b>SEPR</b> - Medium temperature (-8°C)			3.99	4.09	4.11	4.02	4.05	4.07	4.08	4.08
			with AC Fans		5.05	4.90	4.95	4.98	4.95	5.35	5.33	5.18
Process Application	Seasonal energy efficiency <sup>(3)</sup> <b>η<sub>s,c</sub></b>			199	193	195	196	195	211	210	204	
		Seasonal Energy Performance Ratio <sup>(4)</sup> <b>SEPR</b> - High temperature (7°C)			6.56	6.68	6.59	6.77	6.62	7.00	6.85	6.68
			Seasonal Energy Performance Ratio <sup>(5)</sup> <b>SEPR</b> - Medium temperature (-8°C)			3.99	4.09	4.11	4.02	4.05	4.07	4.08
<b>Heating mode</b>												
Net Heating Capacity		kW		210.8	242.6	270.3	299.3	341.8	350.1	392.5	434.3	
Total absorbed power <sup>(1)</sup>		kW		68.6	79.2	85.6	97.2	112.3	122.7	127.2	142	
COP				3.07	3.06	3.16	3.08	3.04	3.11	3.08	3.06	
Eurovent energy class <sup>(1)</sup> - Full load operation				B	B	B	B	B	A	B	B	
Comfort Application	Seasonal Coefficient of Performance <sup>(6)</sup> <b>SCOP</b>	Seasonal energy efficiency <sup>(7)</sup> <b>η<sub>s,h</sub></b>		139	140	143	141	144	151	150	143	
		with AC Fans	Seasonal Coefficient of Performance <sup>(6)</sup> <b>SCOP</b>		3.55	3.58	3.65	3.6	3.68	3.85	3.83	3.65
			Seasonal energy efficiency <sup>(7)</sup> <b>η<sub>s,h</sub></b>		139	140	143	141	144	151	150	143
		Seasonal energy efficiency class <sup>(8)</sup>				A+	A+	A+	A+	A+	A+	A+
<b>Refrigeration circuit</b>												
Number of circuits				2	2	2	2	2	2	2	2	
Refrigerant charge (circuit 1)		kg		22	23	23	23	23	37	37	42.5	
Refrigerant charge (circuit 2)		kg		23	23	37	37	40	37	42.5	42.5	
Refrigerant charge (total)		kg		45	46	60	60	63	74	79.5	85	
Type of expansion valve				Electronic expansion valve								
<b>Compressors</b>												
Number of compressors				2+2	2+2	2+2	2+3	2+3	3+3	3+3	3+3	
Type				Tandem	Tandem	Tandem	Tandem / Trio	Tandem / Trio	Trio	Trio	Trio	
Capacity steps				0-21-50-71-100	0-25-50-75-100	0-23-50-73-100	0-20-40-60-80-100	0-18-39-57-79-100	0-17-33-50-67-83-100	0-15-33-48-67-85-100	0-17-33-50-67-83-100	
Rotation Speed (RPM)				2900	2900	2900	2900	2900	2900	2900	2900	
Oil type				BVC32	BVC32	BVC32	BVC32	BVC32	BVC32	BVC32	BVC32	
Oil load		kg		2 x 2 x 3.6 + 2 x 1	2 x 2 x 6.1 + 2 x 2	2 x 2 x 6.1 + 2 x 2	2 x 6.1 + 3 x 6.1 + 2 x 5	2 x 6.1 + 3 x 6.1 + 2 x 5	2 x 3 x 6.1 + 2 x 5	2 x 3 x 6.1 + 2 x 5	2 x 3 x 6.1 + 2 x 5	
<b>Condenser</b>												
Number of condensers				4	4	6	6	6	8	8	8	
<b>Condenser fan</b>												
Number of condenser fans				4	4	6	6	6	8	8	8	
Nominal airflow rate		m <sup>3</sup> /h		87726	87726	108024	108024	131589	128347	151836	175453	
Rotation speed (rpm)				950 / 950	950 / 950	950 / 700	950 / 700	950 / 950	700 / 700	700 / 950	950 / 950	
<b>Evaporator</b>												
Number of evaporators				1	1	1	1	1	1	1	1	
Nominal water flow rate		m <sup>3</sup> /h		36.56	42.93	47.3	52.38	59.03	63.12	69.81	76.07	
Nominal pressure drop		kPa		29.47	28.83	34.72	42.25	49.07	29.69	32.80	38.65	
Water volume		L		19.5	27.3	27.3	27.3	30.9	42.12	45.24	45.24	
Hydraulic service pressure without hydraulic module		kPa		1000								
<b>Hydraulic module (option)</b>												
Type of pump - Low or high pressure pump				Stainless steel centrifugal single or twin pump mounted in parallel								
Expansion vessel volume		L		50								
Hydraulic service pressure with pump(s)		kPa		1000								
Insulated water tank		L		500		500/1000						
Hydraulic service pressure with pump(s) and water tank		kPa		350								
<b>Hydraulic connections</b>												
Type of standard connection				Victaulic								
Inlet / Outlet connection diameters				4"	4"	4"	4"	4"	5"	5"	5"	
Inlet / Outlet external diameters		mm		4"	4"	4"	4"	4"	5"	5"	5"	
Type of optional connection				Flange DN 100				Flange DN 125				
<b>Electrical data</b>												
Power supply				400V / 3 / 50Hz + E								
Maximum power		kW		96	108.4	118.5	133	152.7	157.7	177.4	197.1	
Maximum running current		A		160.4	176.6	193.9	216.8	249.2	256.9	289.3	321.8	
Starting current		A		325.1	327.2	375.8	367.4	431.1	407.6	471.2	503.7	
Short circuit unit capacity		kA		50								
Power factor				0.864	0.886	0.882	0.885	0.884	0.886	0.885	0.884	
<b>Acoustic data</b>												
Global sound power level - Standard unit		dB(A)		92	92	92	92	94	92	94	95	
Global sound power level Low noise unit with acoustic jacket		dB(A)		90	90	89	89	92	88	91	93	
<b>Dimensions</b>												
Length		mm		2704		3976			5248			
Width		mm		2250								
Height with standard fan(s) and HIFP*		mm		2401.5								
Height with SFAC*		mm		2401.5								
Operating weight		kg		1883	2004	2474	2614	2695	3203	3291	3338	

(1) EUROVENT certified data, in accordance with standard EN 14511 : Cooling mode : Evaporator water temperature = 12/7°C / Outdoor air temperature = 35°C Heating mode : Condenser water temperature = 40/45°C / Outdoor air temperature = 7°C  
(2) SEER in accordance with standard EN 14825.  
(3) Following ecodesign regulation EU 2016/2281 on space cooling, normalized leaving water temperature at 7°C, in accordance with standard EN 14825.  
(4) Following ecodesign regulation EU 2016/2281 on process cooling units, normalized leaving water temperature at 7°C, in accordance with standard EN 14825.  
(5) Following ecodesign regulation EU 2015/1095 on process cooling chillers, normalized leaving water temperature at -8°C, in accordance with standard EN 14825  
(6) SCOP in accordance with standard EN 14825. Heating mode performance is defined for average climate conditions.  
(7) Following ecodesign regulation EU 813/2013 on space heaters, normalized leaving water temperature at 35°C, in accordance with standard EN 14825, average climate conditions.  
(8) Following energy labelling regulation EU 811/2013 on space heaters.

FAN DATA

F Box  
GAC220DP2M

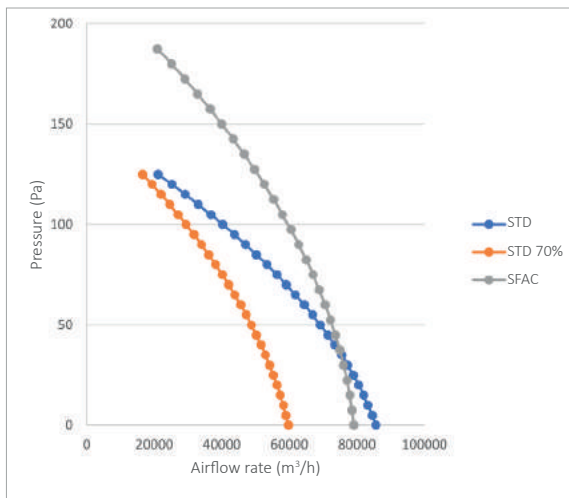

F Box  
GAC250DP2M / GAC300DP2M

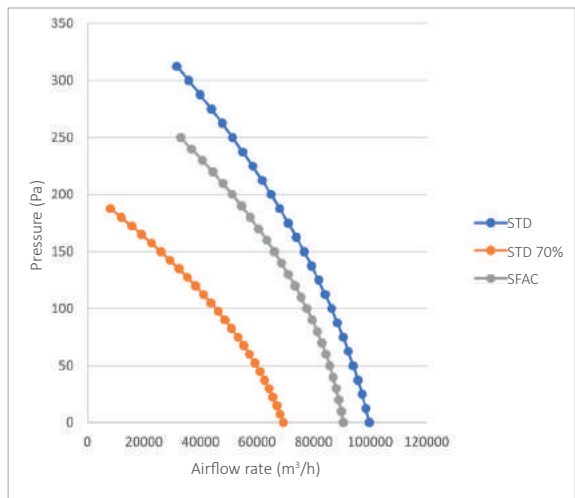

G Box  
GAC330DP2M

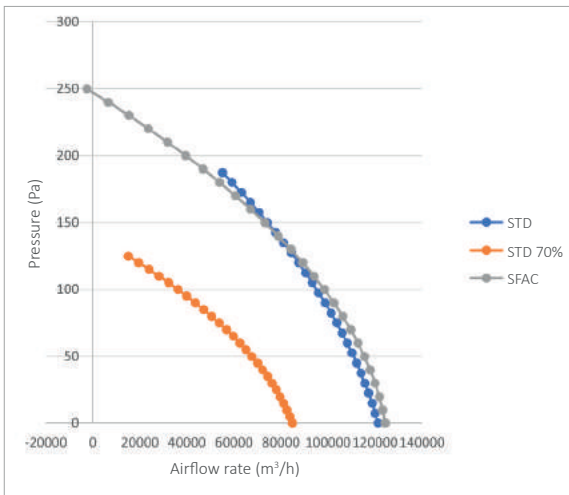

G Box  
GAC370DP2M

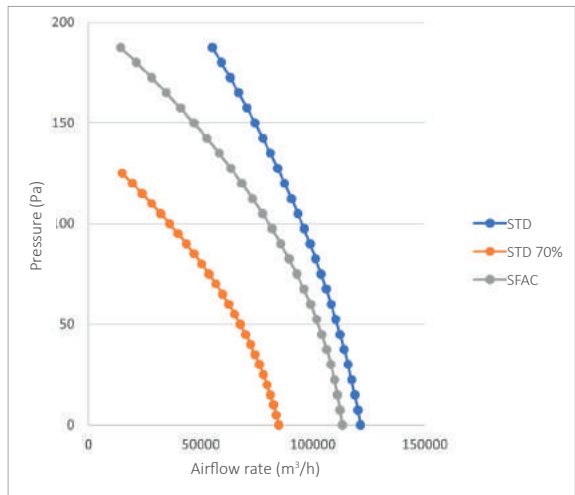

G Box  
GAC400DP2M

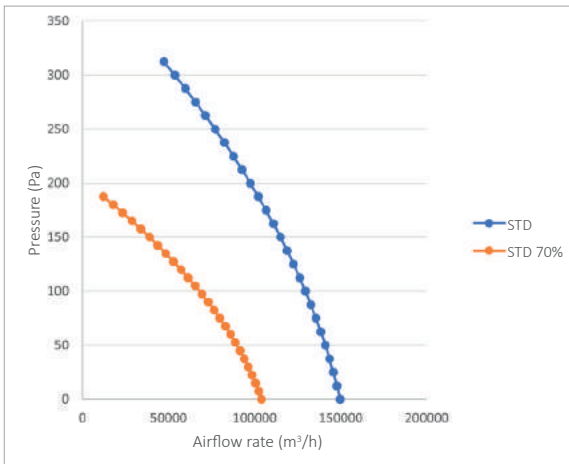

<b>STD</b>	Standard unit
<b>SFAC</b>	Standard AC fan

FAN DATA

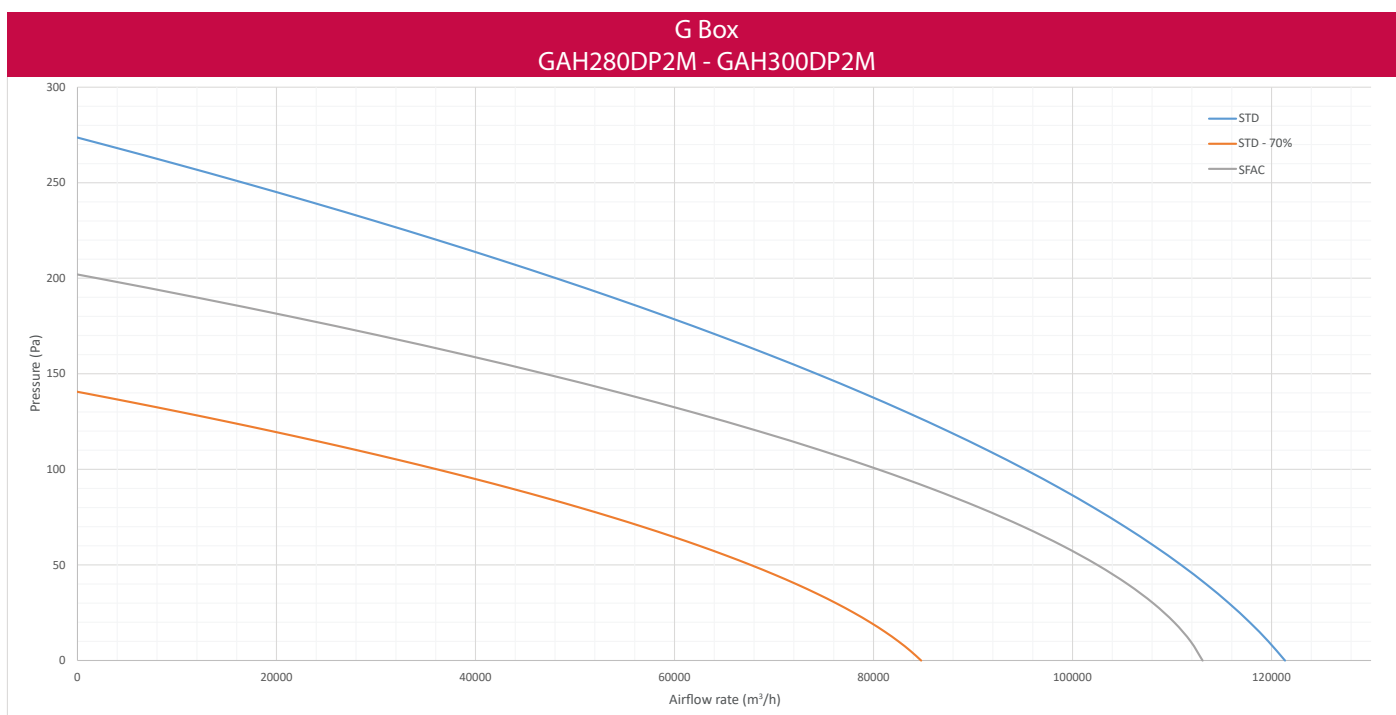
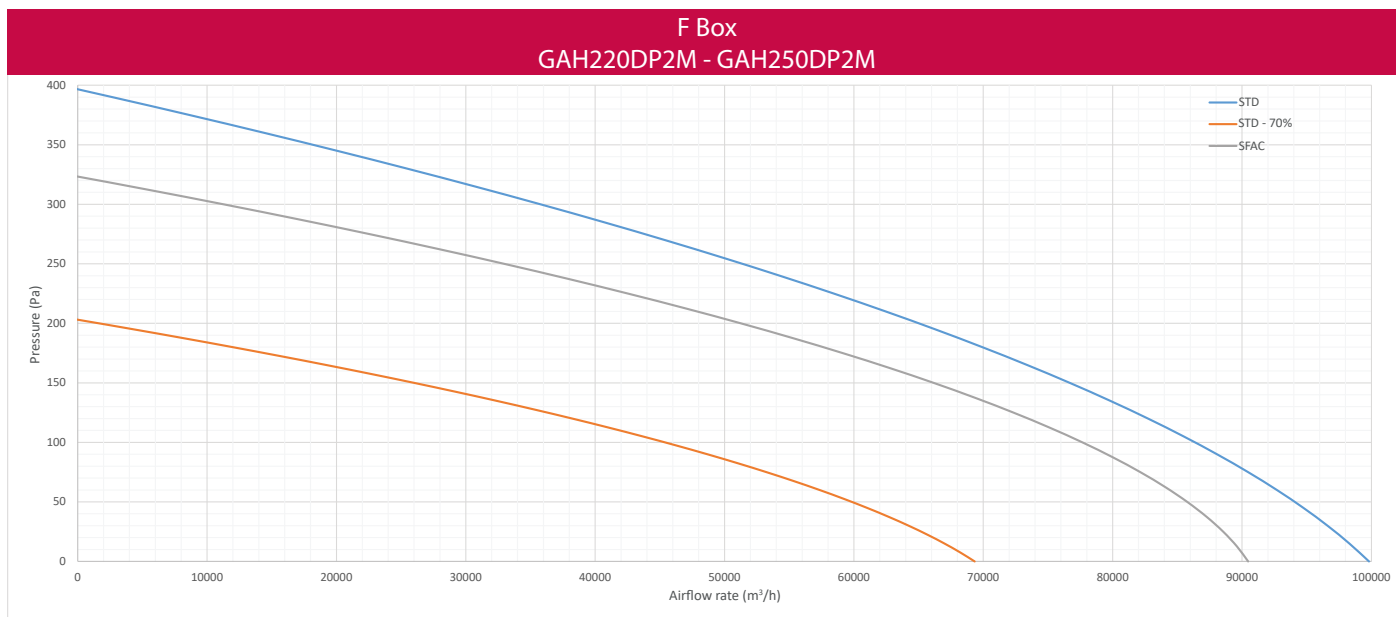

<b>STD</b>	Standard unit
<b>SFAC</b>	Standard AC fan

FAN DATA

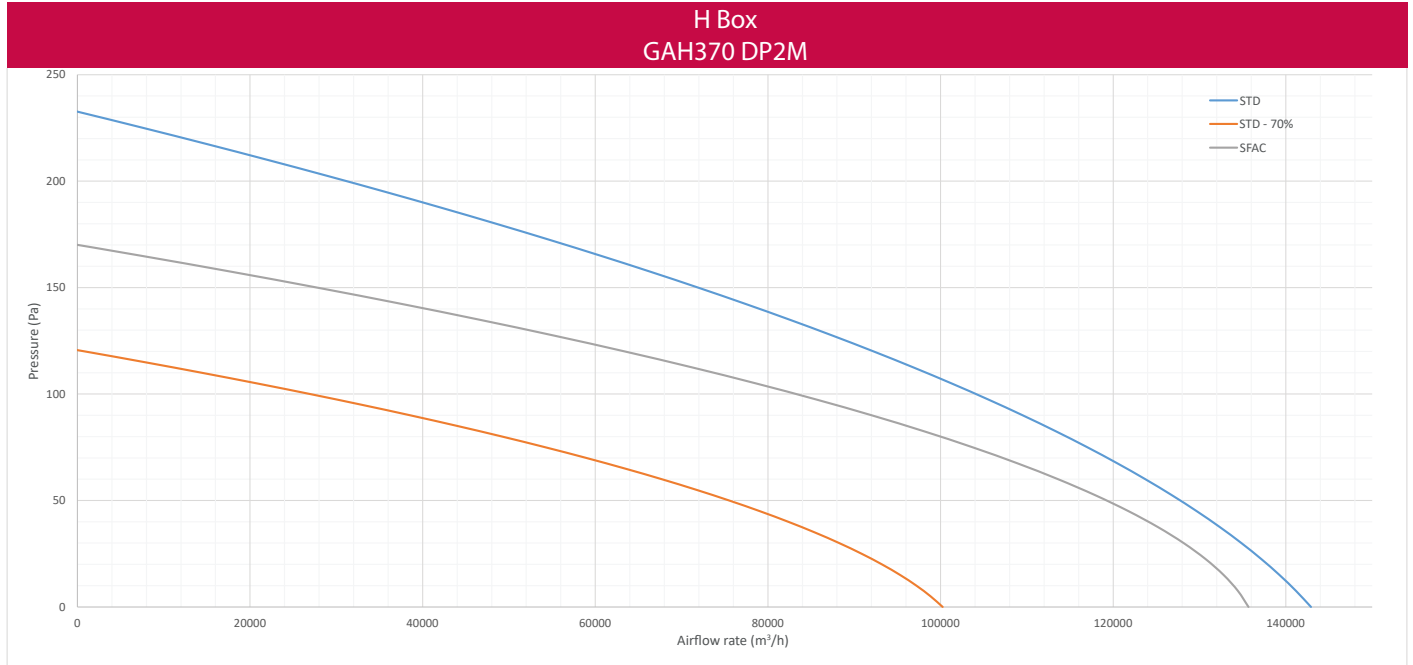
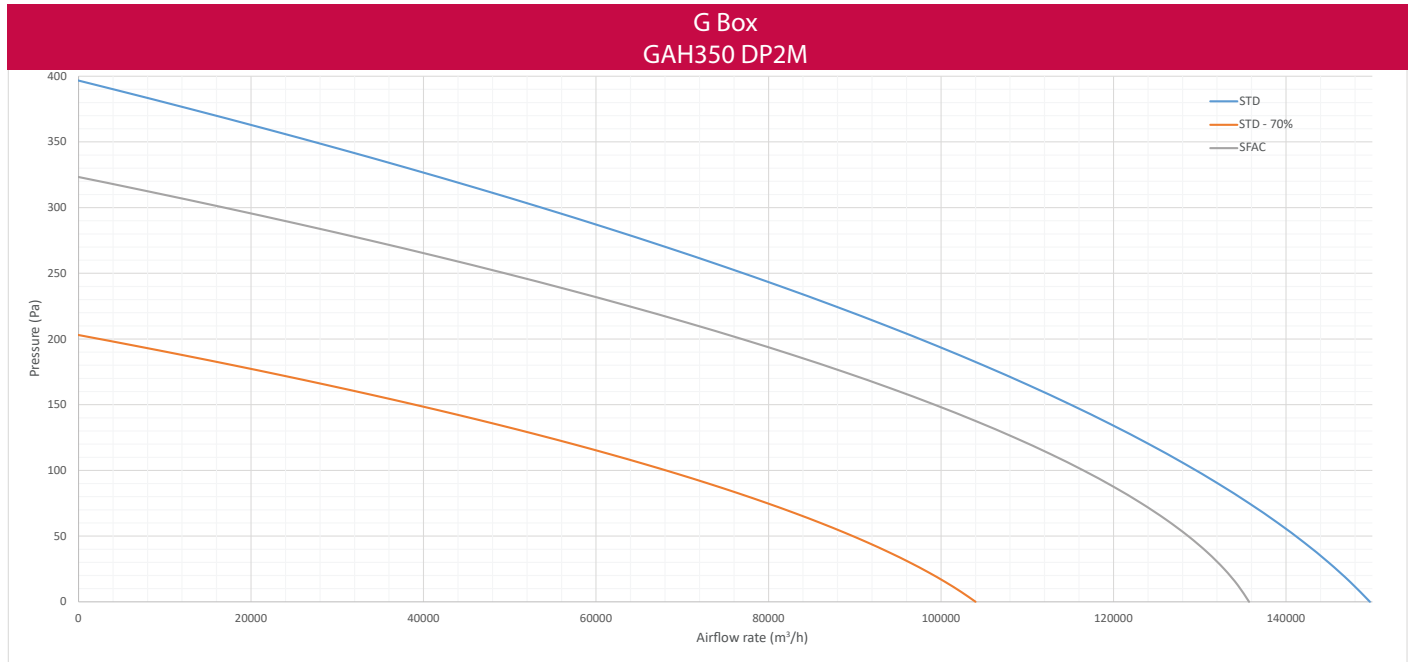

<b>STD</b>	Standard unit
<b>SFAC</b>	Standard AC fan

FAN DATA

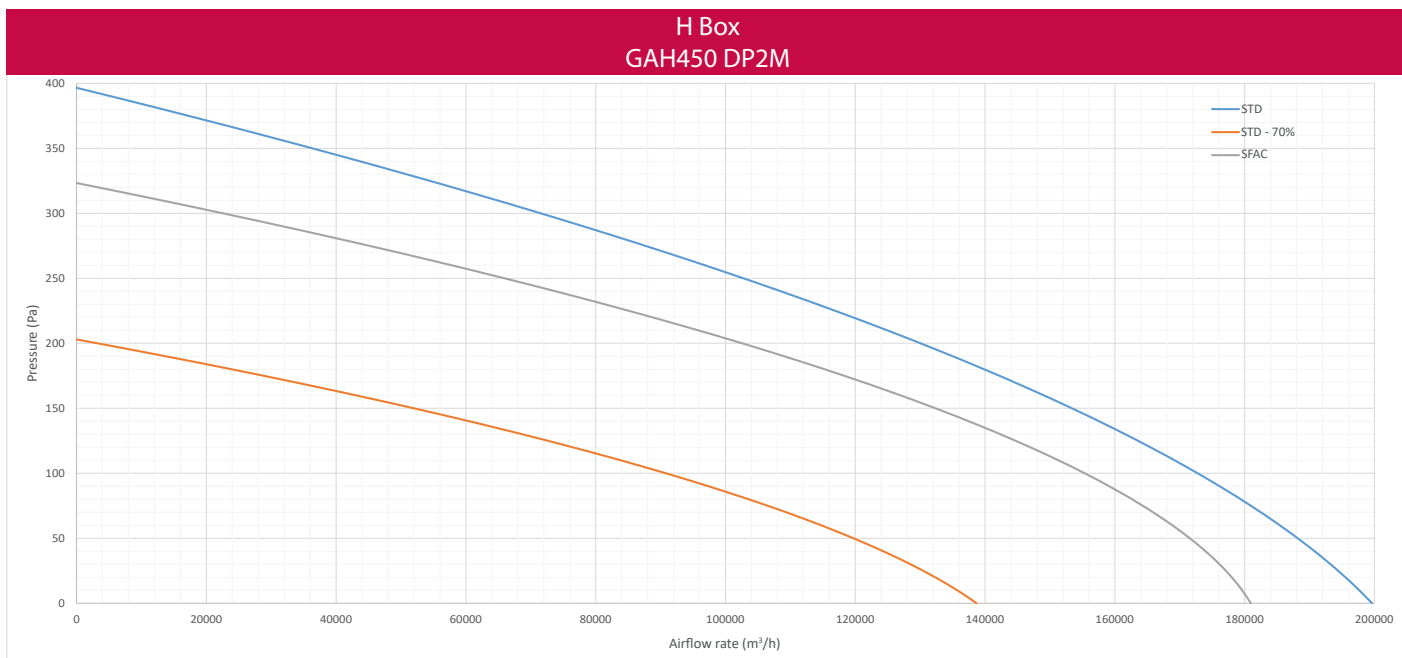
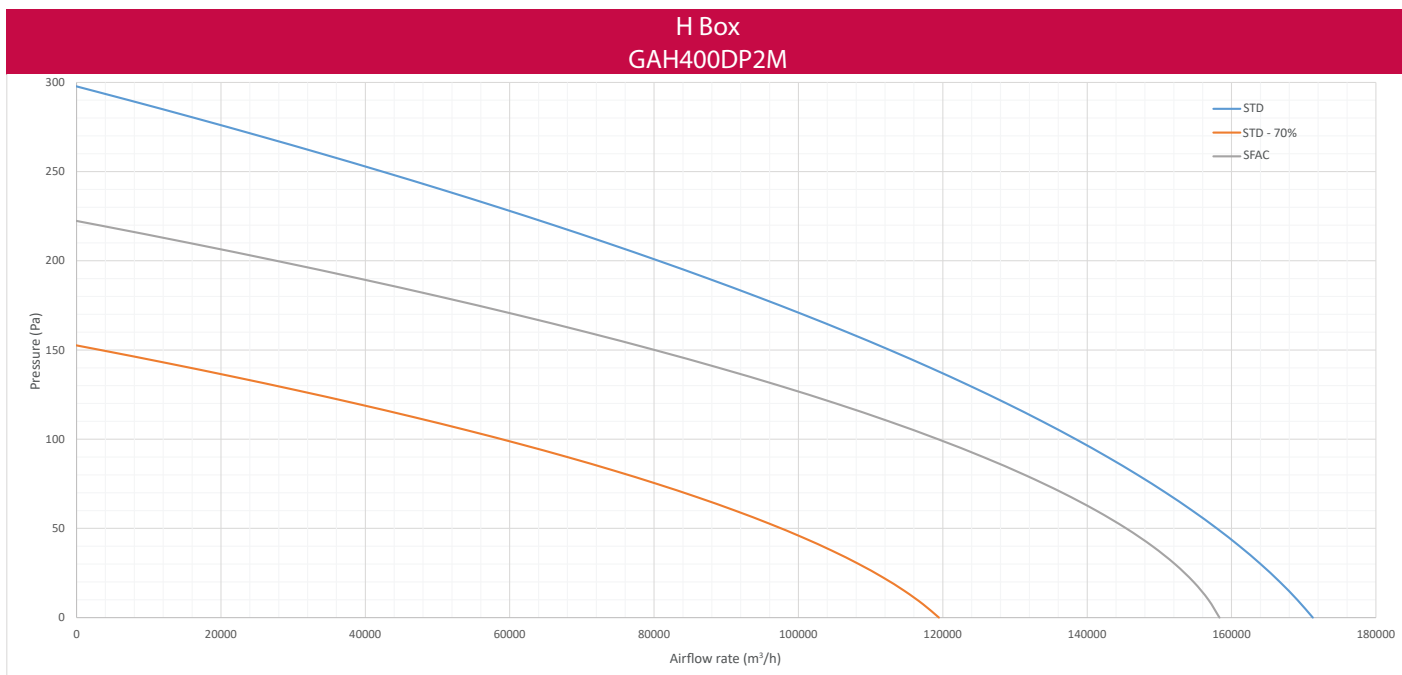

<b>STD</b>	Standard unit
<b>SFAC</b>	Standard AC fan

WATER PRESSURE DROPS



INSTALLATION ADVICE

The units MUST be fitted with a water filter at the inlet to the unit (trapping any particles with a diameter greater than 1 mm.)

PRESSURE DROP OF THE UNIT WITHOUT WATER FILTER

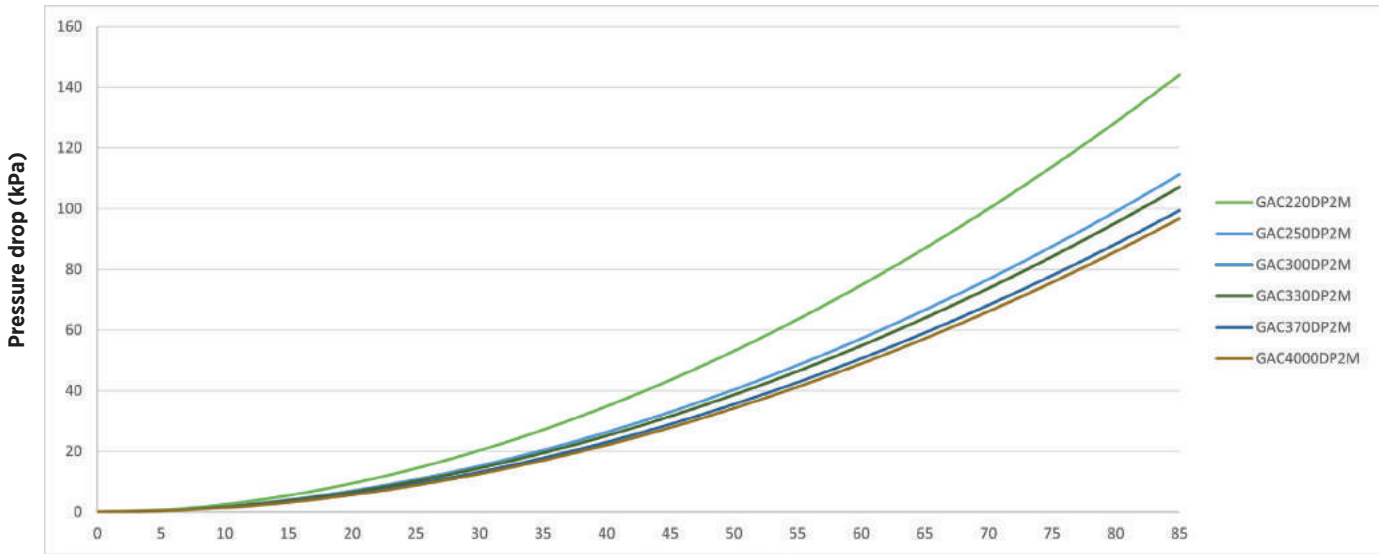

Water flow rate (m³/h)

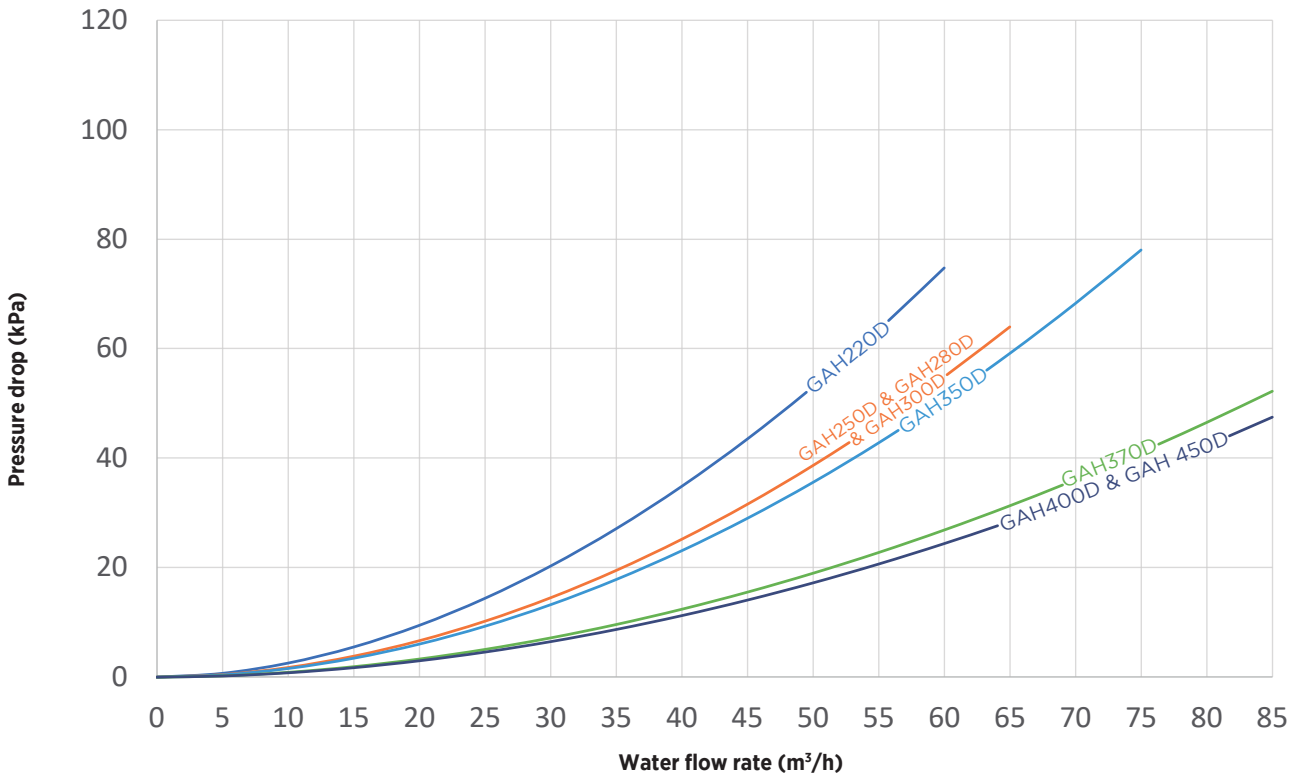

Filter included as standard.

WATER PRESSURE DROPS



INSTALLATION ADVICE

The units MUST be fitted with a water filter at the inlet to the unit (trapping any particles with a diameter greater than 1 mm.)

PRESSURE DROP FOR OPTION WATER FILTER

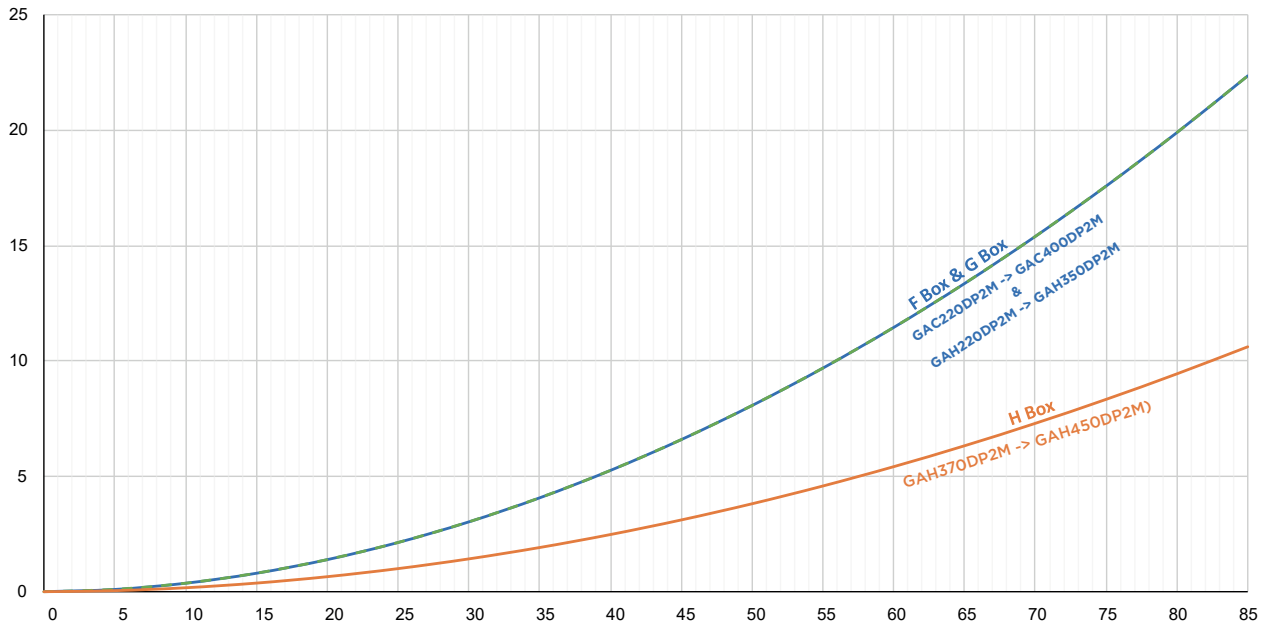

Filter included as standard.

STANDARD UNIT

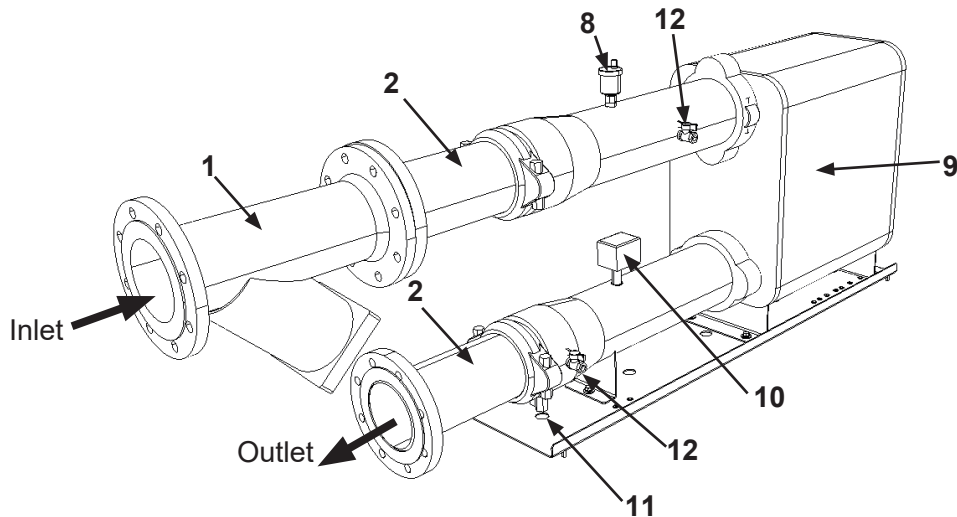

UNIT WITH WATER PUMP OPTION

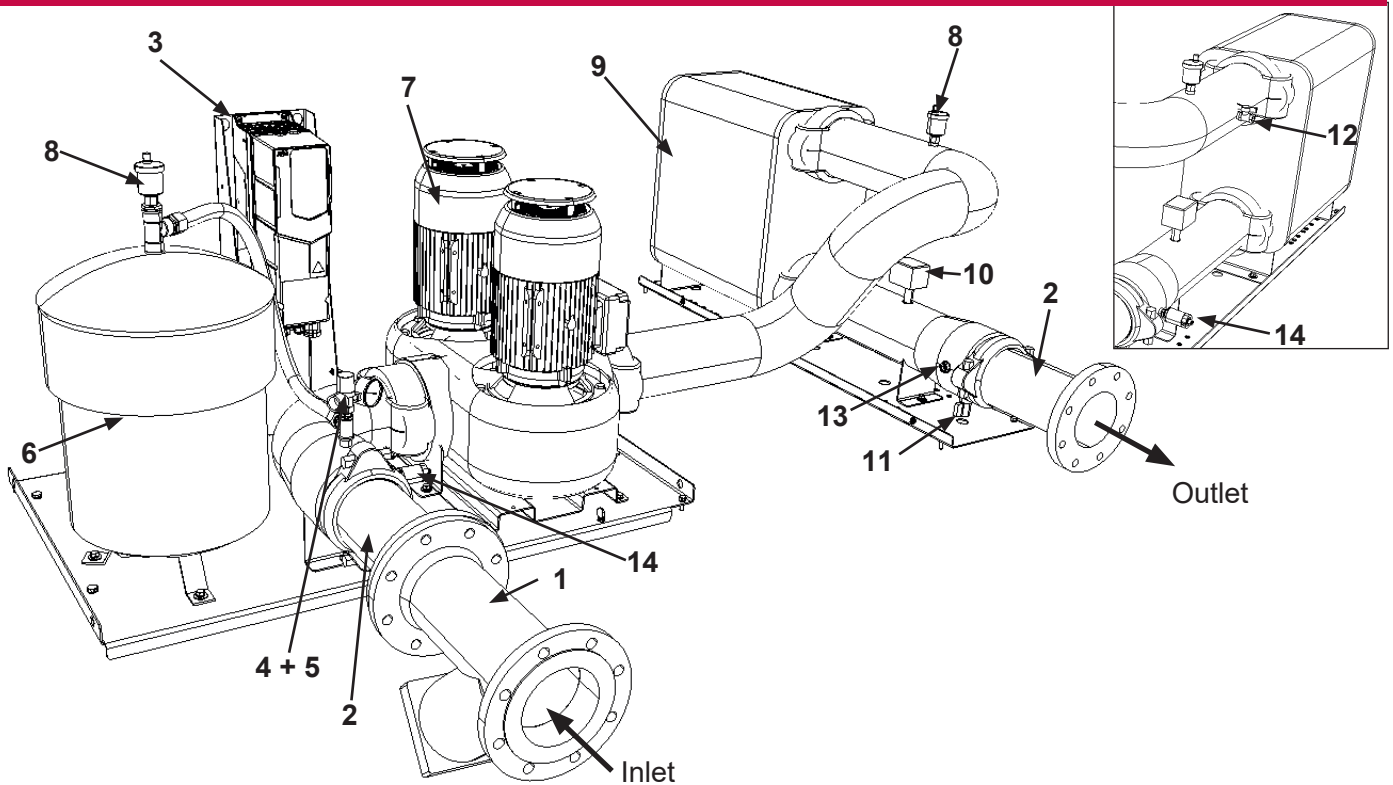

COMPONENTS:

STANDARD VERSION	UNIT WITH WATER PUMP OPTION
8, 9, 10, 11, 12, 13	4, 5, 6, 7, 8, 9, 10, 11, 12, 13, 14

1	Water filter (additional option, supplied loose)	6	Expansion vessel (additional option)	11	Drain valve
2	Flange connection (additional option, supplied loose)	7	Water pump (single or twin)	12	Pressure tap
3	Variable speed Inverter (when variable water flow option is selected)	8	Air purge valve	13	Water temperature sensor
4	Safety valve (additional option)	9	Plate exchanger	14	Pressure tap or pressure transducer (when variable water flow option is selected)
5	Pressure gauge (additional option)	10	Pallet flow switch		

The use of a water filter in the circuit upstream of the heat exchanger is mandatory. These filters must remove all particles with a diameter greater than 1 mm, and must be positioned within 1 meter of the inlet of the exchanger. They may be supplied as an option by the manufacturer.

WATER PUMPS DATA

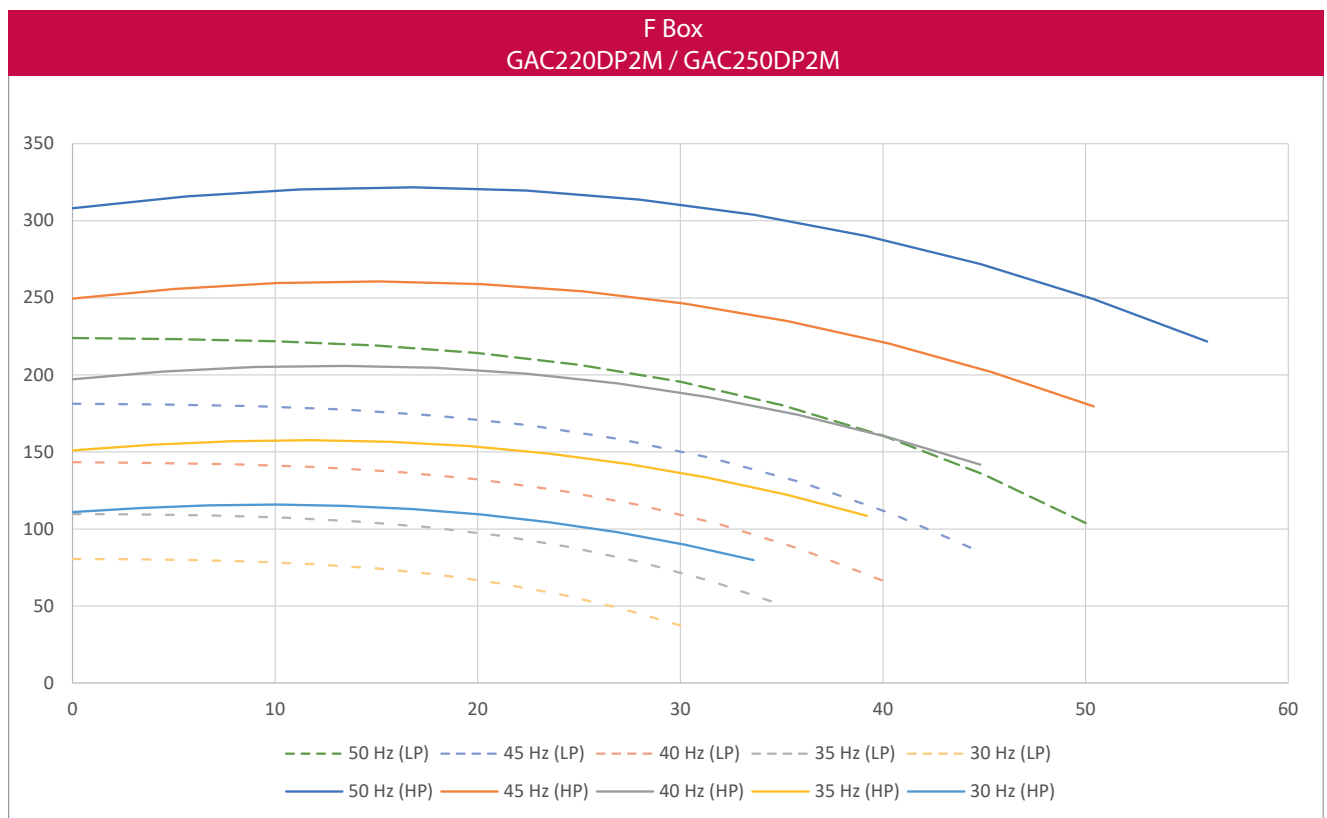

<b>LP</b>	Low pressure
<b>HP</b>	High pressure

WATER PUMPS DATA

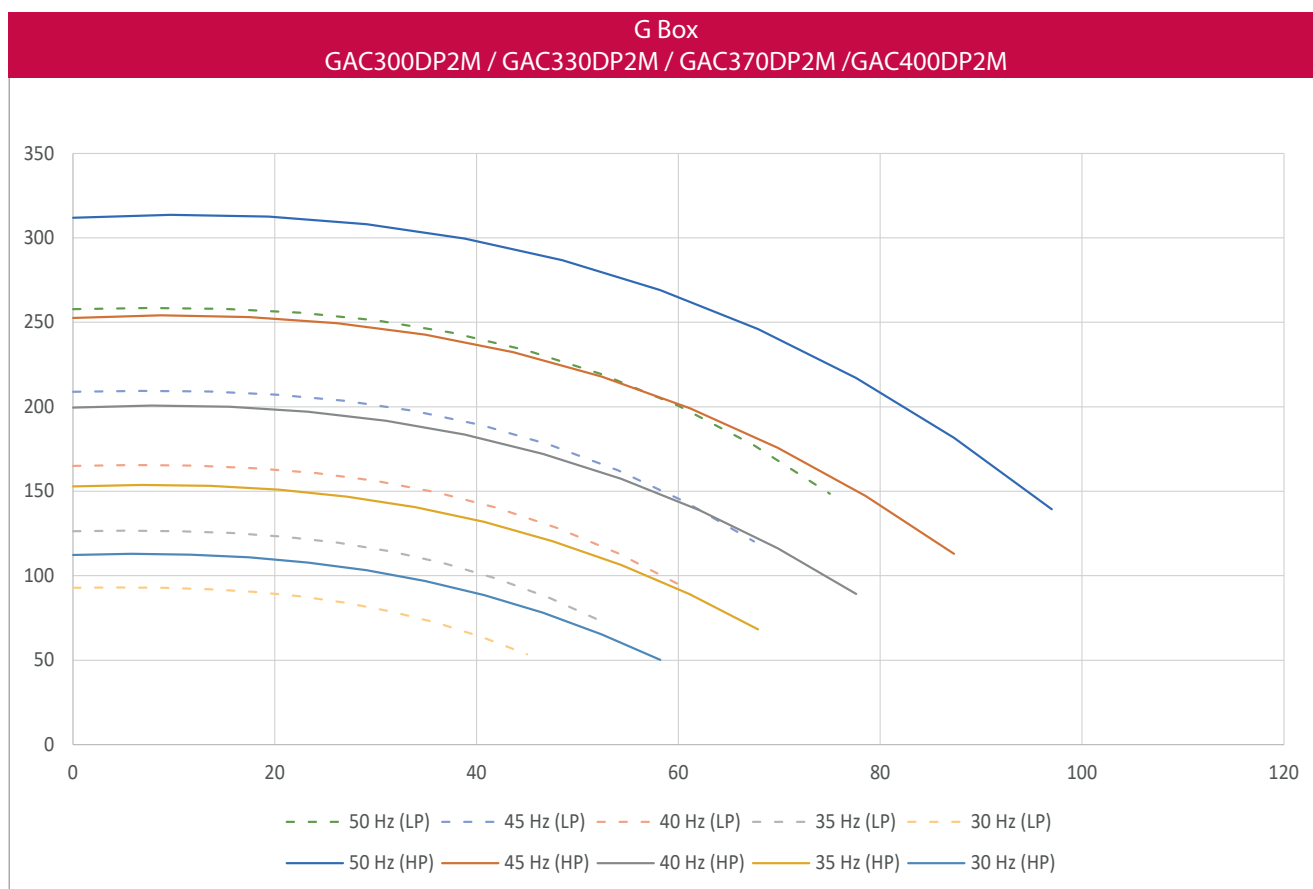

<b>LP</b>	Low pressure
<b>HP</b>	High pressure

WATER PUMPS DATA

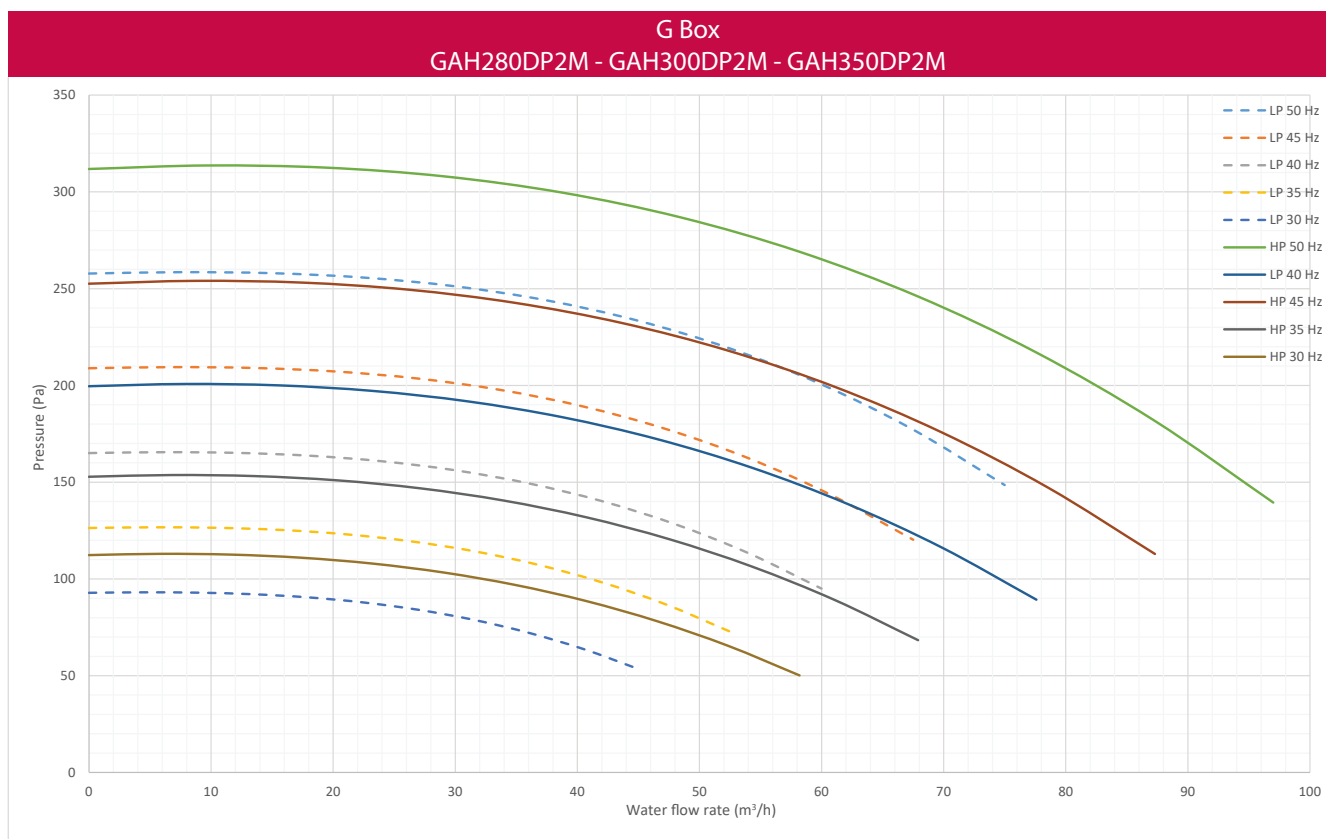
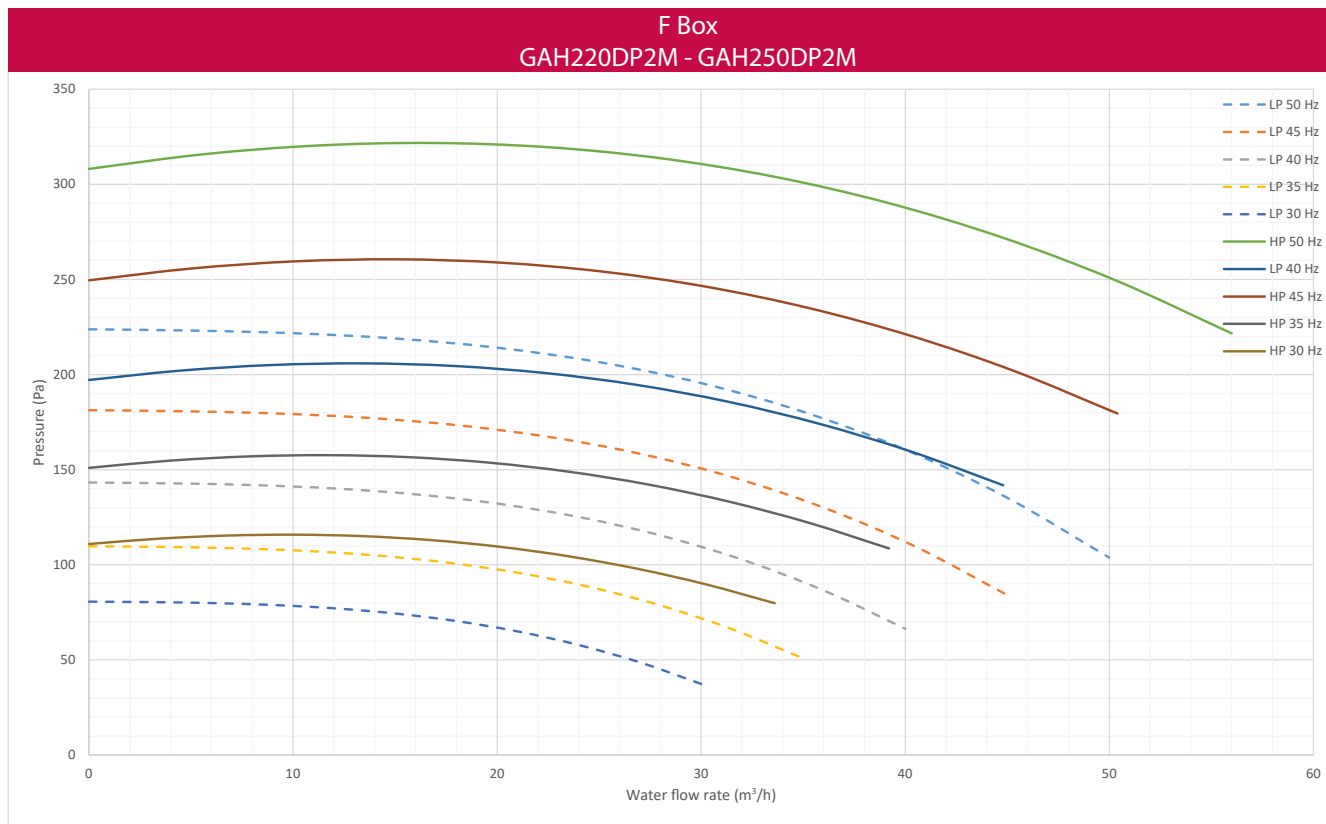

<b>LP</b>	Low pressure
<b>HP</b>	High pressure

WATER PUMPS DATA

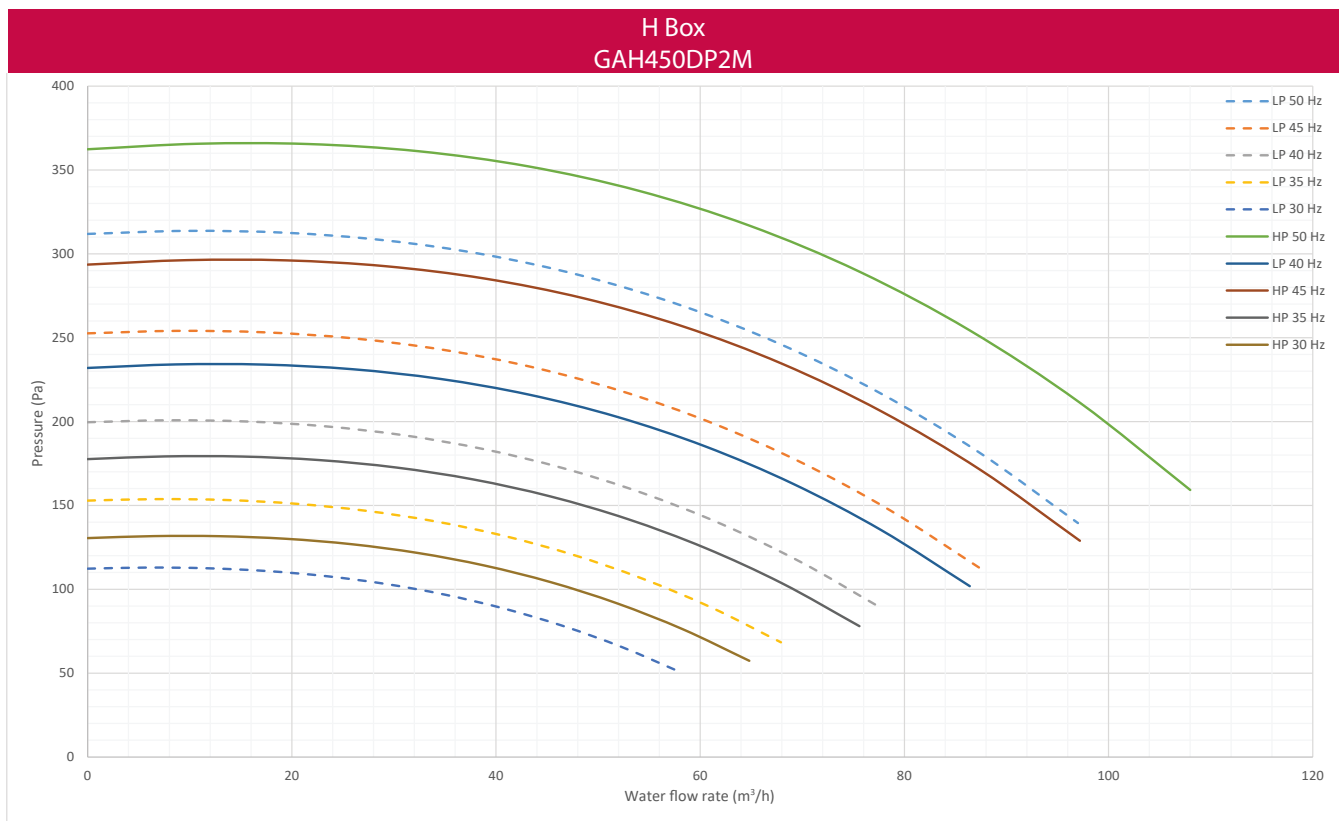
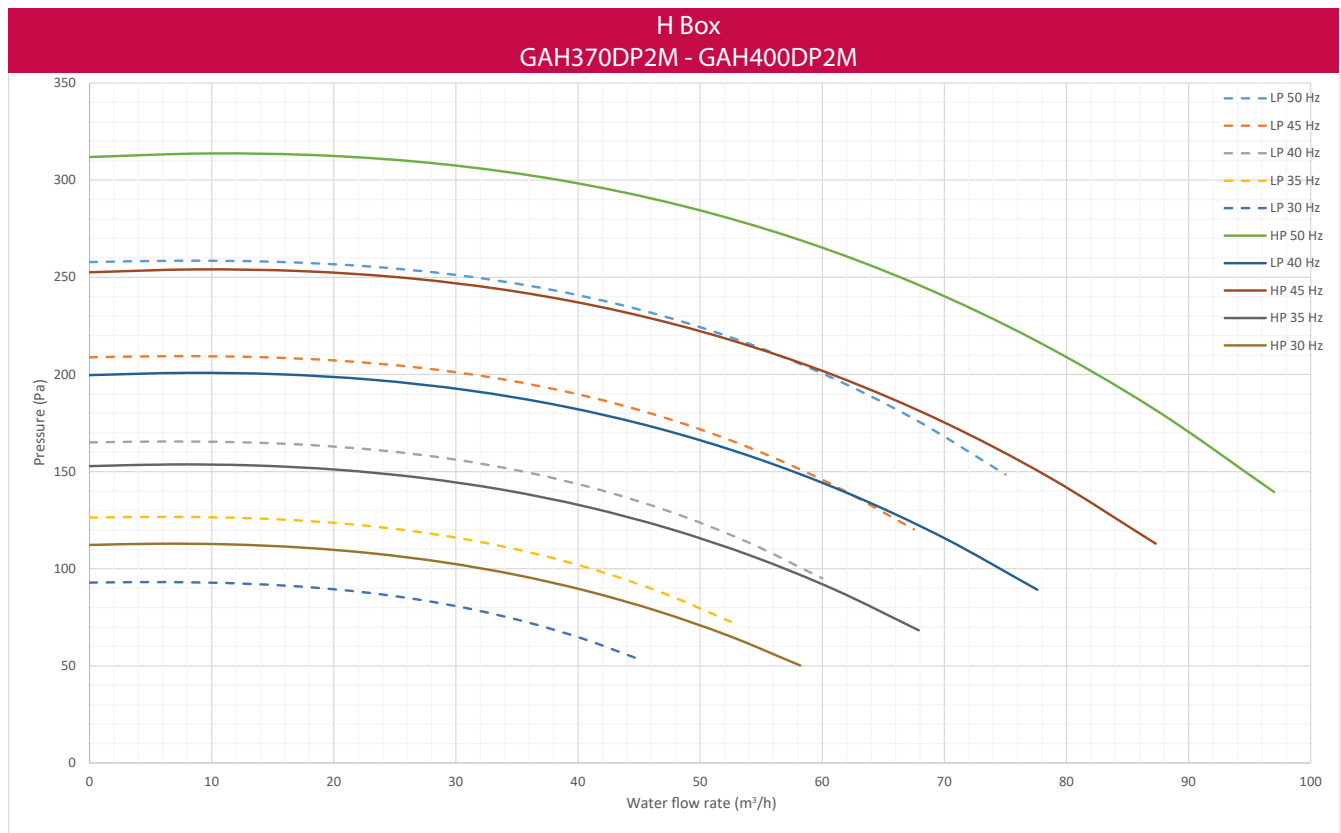

<b>LP</b>	Low pressure
<b>HP</b>	High pressure

GLYCOL SOLUTION UNIT

If the outside temperature where the system is to be installed or the water outlet temperature is likely to drop below 5°C, it is very important to use glycol anti-freeze.

The amount of anti-freeze required will vary depending on the minimum ambient temperature or the water outlet temperature. When the percentage of glycol increases the standard pump flow decreases, the pressure drop increases and the cooling and thermal capacities drop. As a result the minimum flow must be multiplied by the coefficient shown in the table:

	Minimum ambient temperature or water outlet temperature			
	+ 5°C → 0°C	0 °C → - 5°C	-5°C → - 10°C	- 10°C → - 15°C
Ethylene glycol %	10%	20%	30%	35%
Pressure drop	1,05	1,10	1,15	1,18
Water flow	1,02	1,05	1,08	1,10
Power input	0,997	0,996	0,995	0,994
Capacities Cooling mode	0,995	0,985	0,975	0,965
Capacities Heating mode	0,994	0,993	0,99	0,987

Example : 10% glycol  
 Pressure drop : 210 x 1,05  
 Minimum flow : 12,38 m<sup>3</sup>/h x 1,02  
 System capacity x 0,99

WATER VOLUME

MINIMUM WATER VOLUME IN THE INSTALLATION

Thanks to an intelligent algorithm and short cycle protection of compressors, eCOMFORT can operate with low volumes of water. The water volume of the installation (piping + exchangers) must be capable of storing the energy supplied by the chilled water cooler or the heat pump during the minimum operating time. When this volume is insufficient, a buffer tank must be installed.

The minimum capacity in liters of water of the whole installation is then expressed by the following formula :

$$\text{Minimum water loop volume (litre)} = \frac{\text{Minimum capacity stage (kW)} \times \text{Minimum operating time (s)} \times 1000}{\text{Water density (1000 kg/m}^3\text{)} \times \text{Water specific heat (4,18 kJ/Kg.}^\circ\text{C)} \times \text{Acceptable temperature deviation (}^\circ\text{C)}}$$

This formula may be simplified that way :

$$\text{Minimum water loop volume (litre)} = \text{Water density (1000 kg/m}^3\text{)} \times \frac{\text{Minimum capacity stage (kW)} \times \text{Minimum operating time (s)} \times 1000}{\text{Acceptable temperature deviation (}^\circ\text{C)}}$$

Size GAC	Nominal cooling capacity	Minimum capacity step	Minimum water content of the installation (L)			Minimum water flow rate	Nominal water flow rate	Maximum water flow rate
	Kw	%	(acceptable deviation 6°C)	(acceptable deviation 4°C)	(acceptable deviation 2°C)	m³/h		
<b>Standard compressor</b>								
<b>220</b>	214	21%	323	484	968	18.5	36.9	55.4
<b>250</b>	250	25%	449	673	1346	21.6	43.1	64.7
<b>300</b>	300	25%	524	786	1572	25.9	51.7	77.6
<b>330</b>	330	22%	516	774	1549	28.1	56.2	84.3
<b>370</b>	370	20%	520	779	1559	31.3	62.6	93.9
<b>400</b>	400	18%	524	787	1573	35.1	70.1	105.2

Size GAH	Nominal cooling capacity	Nominal heating capacity	Minimum capacity step	Minimum water content of the installation (L)			Minimum water flow rate	Nominal water flow rate	Maximum water flow rate
	Kw	Kw	%	(acceptable deviation 6°C)	(acceptable deviation 4°C)	(acceptable deviation 2°C)	m³/h		
<b>Standard compressor</b>									
<b>220</b>	212	211	21%	319	478	957	18.5	37.0	56.0
<b>250</b>	249	243	25%	446	669	1338	21.4	42.8	56.0
<b>280</b>	274	270	23%	452	678	1356	23.8	47.6	79.1
<b>300</b>	304	299	20%	435	653	1306	26.1	52.3	86.8
<b>350</b>	342	342	18%	441	662	1324	29.5	59.0	97.0
<b>370</b>	366	350	17%	446	669	1338	31.5	63.0	97.0
<b>400</b>	405	392	15%	435	653	1305	34.8	69.7	97.0
<b>450</b>	441	434	17%	537	806	1612	38.1	76.2	97.0

Note: In cases where the unit operates with a low volume of water with an air handling unit or if the unit is used for industrial processes, the buffer tank is essential (see the section on hydraulic options).

Note: In cases where the unit operates with a low volume of water with an air handling unit or if the unit is used for industrial processes, the buffer tank is essential (see the section on hydraulic options). For heat pump applications, we also recommend using a buffer tank to maintain a stable temperature during defrost cycles. In addition, the eCOMFORT unit equipped with modulating immersion heaters in the balloon guarantees and secures the thermal.

**MAXIMUM WATER VOLUME IN THE INSTALLATION**

The units with hydraulic module include a expansion vessel. The table below details the maximum water volume in the system.

If the water volume in the system is greater than that detailed in the table, it will be necessary to add additional expansion vessel(s).

The system design must allow for water expansion and contraction.

Models	All sizes
Volume of the expansion vessel (liters)	50 L
Refrigerant	Maximum water volume in Liters
WATER	2145 L
WATER + 10% glycol	1640 L
WATER + 20% glycol	1430 L
WATER + 30% glycol	1240 L
WATER + 35% glycol	950 L

MINIMUM WATER FLOW THROUGH THE EVAPORATOR

In case of installation with fixed speed pump, to prevent from freezing risk, the flow rate through the evaporator must be higher than the minimum flow given in the table below.

In case of variable primary flow, the pump speed must be controlled through the eCLIMATIC control. Additionally, the hydraulic system must be properly designed and balanced to ensure a right water flow distribution through the chiller evaporator and the terminal units.

This is especially important when the system is designed with fan coils equipped with two-way valves. When the two-way valves are closing in response to building load change, it is important that the system is designed to ensure a minimum evaporator flow that is always minimum 60% of the chiller's design flow rate. This can be done with a bypass from chilled water supply to chilled water return opened via a signal from a flow meter.

Additionally, some terminals can be fitted with three way control valves in order to ensure the flow will not drop below the minimum value at any load condition as indicated in the table below.

Size GAC	Water flow rate (m <sup>3</sup> /h)				
	Minimum (DT = 8K)	Nominal	Maximum	Minimum with eDrive	Maximum with eDrive
GAC220DP2M	18.5	36.9	55.4	13.5	55.4
GAC250DP2M	21.6	43.1	64.7	13.5	64.7
GAC300DP2M	25.9	51.7	77.6	26.0	77.6
GAC330DP2M	28.1	56.2	84.3	26.0	84.3
GAC370DP2M	31.3	62.6	93.9	26.0	93.9
GAC400DP2M	35.1	70.1	105.2	26.0	105.2

Size GAH	Water flow rate (m <sup>3</sup> /h)				
	Minimum (DT = 8K)	Nominal	Maximum	Minimum with eDrive	Maximum with eDrive
GAH220DP2M	18.5	37.0	56.0	13.0	56.0
GAH250DP2M	21.4	42.8	56.0	13.0	56.0
GAH280DP2M	23.8	47.6	79.1	21.7	79.1
GAH300DP2M	26.1	52.3	86.8	21.7	86.8
GAH350DP2M	29.5	59.0	97.0	21.7	97.0
GAH370DP2M	31.5	63.0	97.0	21.7	97.0
GAH400DP2M	34.8	69.7	97.0	21.7	97.0
GAH450DP2M	38.1	76.2	97.0	21.7	97.0

E DRIVE TECHNOLOGY, THE RIGHT CHOICE TO SAVE 75% OF PUMP ENERGY COSTS.

LENNOX offers the eDrive, a variable speed drive pump option (with single or double pump) which modulates the water flow through the evaporator and reduces energy costs. This option is available on chillers and heat pumps from 20 to 1000 kW.

In a water system, one major contributor to annual energy consumption is the pump motor. Pumping energy cost can represent 20% of the total cost of owning a chiller. This ratio can be even higher for a heat-pump.

eDrive™ variable speed driven pump is contributing to continuous Lennox efforts to save energy while exploring possibilities to reduce installation cost.

eDrive™ variable speed driven pump benefits:

- Cost savings on the energy consumption especially at part-load conditions and during off period.
- 75% of this energy could be saved !
- Cost savings on the initial system cost. Fewer pumps and piping connections than primary-secondary systems, terminal units equipped with two-way control valves instead of three-way valves, elimination of water flow set valve.
- Flexibility and accuracy in the pump operation control (smooth start and stop, gradual change of speed, accuracy and stability of control)
- Reduction of the repeated stress on the pump and piping resulting in longer equipment life time (elimination of the «hammer blow» in pipes).
- Elimination of the start-up current thanks to variable frequency drive that controls a gradual pump motor supply.

Designing a variable primary flow chilled water plant that performs reliably at all load conditions requires careful attention to chiller design. Thanks to the newest generation of chiller controllers and intensive testing, eCOMFORT can reliably maintain the desired chilled water temperature with a flow range from 60% to 100% that gives up to 75% annual energy savings.

LENNOX eDrive™ Technology modulates the Water Flow especially in Part-Load Conditions through a Specific Algorithm and a Variable Frequency Driver.

TYPICAL COST SPLIT IN A CHILLER THROUGH 15-YEAR LIFESPAN

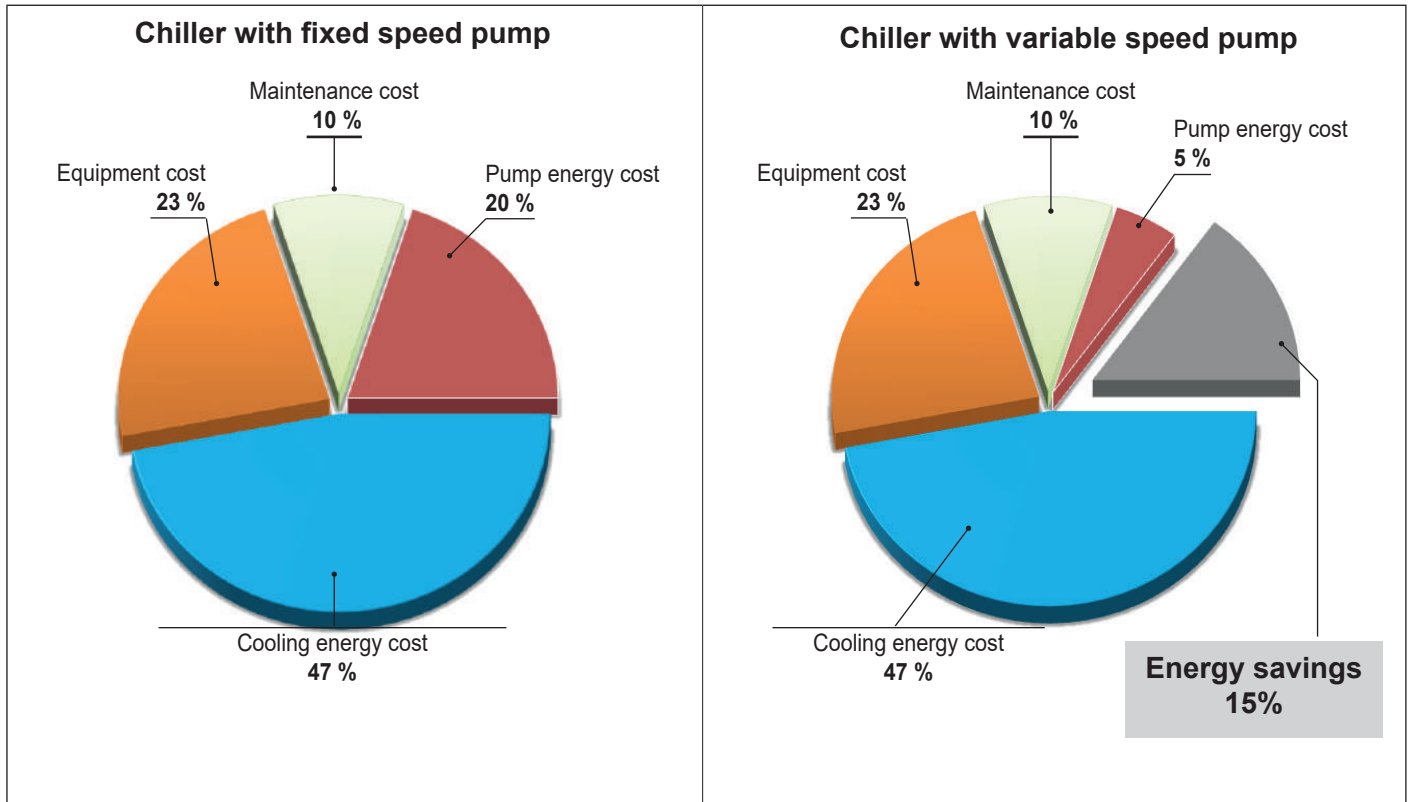

EDRIVE™ VARIABLE WATER FLOW SAVES YOUR MONEY IN THE ENERGY COST

- Through the elimination of the energy normally lost in the water flow control valve during unit full-load operation (Variable water flow = perfect pump curve adjustment to the required nominal water flow and delta P)
- Through pump rotation speed reduction during unit part-load operation.
- Thanks to pump running at minimum speed during Chiller “off” period (night, unoccupied)

Pump energy consumption  
Fan coil with 3 way valves and constant DT

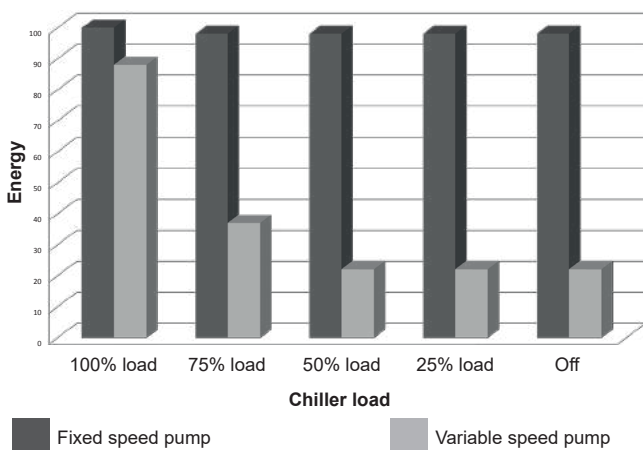

**PUMP AFFINITY LAWS**

“The power required for pumps varies as the cube of the flow rate.”

20% water flow reduction = 50% energy reduction.  
40% water flow reduction = 80% energy reduction.

## EDRIVE VARIABLE WATER FLOW MAY SAVE MONEY IN THE SYSTEM DESIGN COST

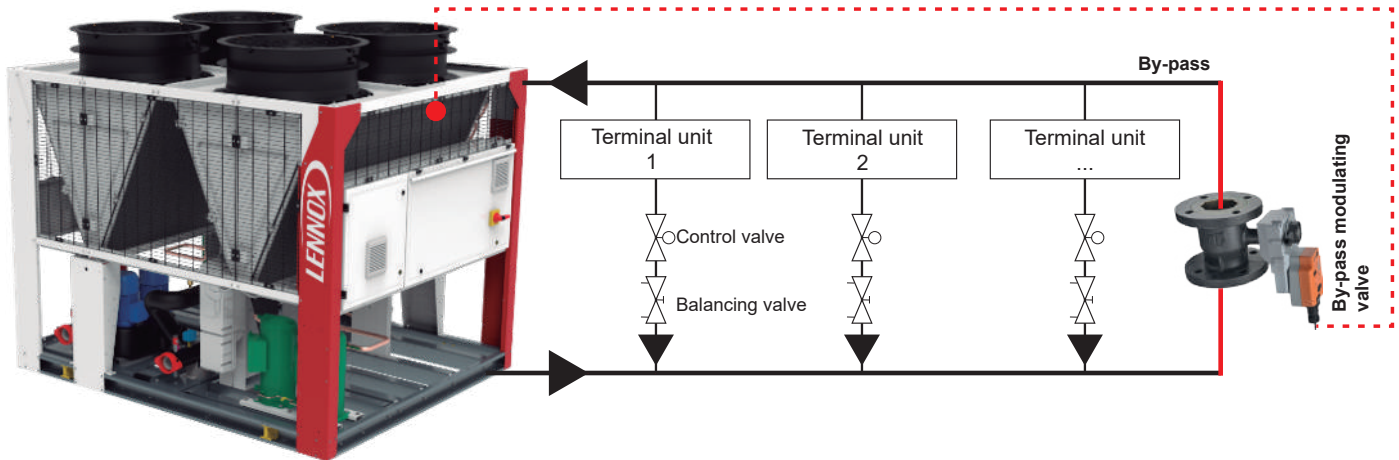

A variable primary flow design uses fewer components than primary-secondary systems as the pumps of the secondary distribution loop and the mixing tank are eliminated.

When compared with constant primary flow systems, terminal units can be equipped with two-way control valves instead of three-way valves often used in constant volume systems. Using two-way valves instead of three-way valves on fan coils represent a budget reduction that pays for the variable frequency driver cost. On top of that, the water flow set valve is eliminated as the pump adjustment to real installation needs can be done electronically. These factors may reduce the initial cost of the chilled water system.

## EDRIVE VARIABLE WATER FLOW BY LENNOX

## 3 CONTROL MODES AVAILABLE :

## Constant speed / Dead zone

- Interest to set the right installation design flow (avoid setting valve).
- Constant Delta P (setting to declare the required working pressure)
- Easy to install and operate with 2 way valves installation.

## Constant Delta T (Setting to declare the required delta T)

- Need a good installation with well balanced circuits to ensure good flow distribution when the flow is reduced.
- Installation with terminal units fitted with 3-way valves.

## OPERATION FOR EACH MODE:

- Constant speed / dead zone : eDrive pilots the pump to the water flow desired when the compressors are in operation. When the compressors are stopped (dead zone), control will automatically reduce the speed of the pump to the minimum water flow. This minimum flow is also adjustable within minimum 30Hz (60% flow).
- Constant delta P : the eDrive™ regulation is managing the pump to maintain the required delta P in order to keep constant the customer available static pressure. When the terminals control valves close in response to decreased building loads, the pump controller slows the pump speed to maintain the target delta P. In this mode the pump does not detect terminal capacity reduction (fan speed staging)
- Constant Delta T : the eDrive™ regulation is managing the pump to maintain the required Delta T. When the Delta T is increasing in response to the number of compressors running, the pump controller increases the speed of the pump. Conversely, when the compressors are stopping in response to decreased building loads, the pump controller slows the pump speed to maintain the target Delta T.

## SAFETY PARAMETERS:

- If the evaporating pressure reaches the low limit (risk of evaporator frosting), the flow is increased.
- If the outlet evaporator temperature reaches the low limit, the flow is set to the maximum.
- When the pump speed varies and the flow switch trips, the flow is automatically increased.
- During defrost procedure (HP), the flow is set to the maximum.
- Pump motor supply range from 30 Hz minimum to 50Hz maximum. Minimum pump motor frequency set at 30Hz. Below this value, risk of pump motor failure due to overheat.
- For safe operation of the chiller, the unit is protected by the flow switch.

- Minimum and maximum admissible water flow per unit size: with constant delta T, the flow may vary from 60% to 100% of the selected pump nominal flow.
- Maximum change in flow rate through the evaporator: a 10% per minute change in flow rate is admissible in most of air conditioning applications.

Installation instructions to respect in case of variable primary flow:

- The hydraulic system will have to be properly designed and balanced to ensure a right water flow distribution through the chiller evaporator and the terminal units.
- The hydraulic system will have to be properly designed to respect minimum and maximum water flow through each chiller following the values given by the manufacturer.

Case of constant Delta P mode :

- In case of system designed with terminal units equipped with 2 way valves, the hydraulic system will need to have a bypass flow to ensure a minimum water flow through the chiller evaporator.
- By-pass method :
  - Bypass adequate water flow can be achieved with a slow modulating opening as soon as the water flow rate is near the minimum. When the water flow rises according to predefined setting, this valve closes. This bypass modulating valve provided by LENNOX as an option is controlled by our eClimatic control. The bypass should be positioned at the beginning of the installation near the unit and allows significant energy savings and cost as opposed to a location at the end of the system.
  - An alternative is to install some 3-way valves at different points of the terminal units. This approach allows constant minimum flow in the chiller or heat pump and ensures a cheaper system.
- The minimum water flow through the chiller evaporator will need to respect a minimum value that is 60% of the nominal chiller water flow.
- The flow bypass from chilled water supply to chilled water return can be done with a motorized bypass valve opened via a signal from a flow meter.
- For safe operation some terminals can be equipped with three way control valves in order to ensure the flow will not drop below the minimum value at any load condition.
- The water flow must not vary by more than 10% per minute.
- Check the control valve authority in low load periods, especially in case of long pipe hydraulic systems.

OPERATING WEIGHT OF ADDITIONAL OPTION (KG)

## COOLING ONLY UNITS

Option	Hydraulic module	220D	250D	300D	330D	370D	400D
SPLP	Low-pressure single pump	117	117	134	170	170	170
DPLP	Low-pressure twin pump	167	167	239	239	239	239
SPHP	High-pressure single pump	126	126	139	174	174	174
DPHP	High-pressure twin pump	195	195	284	268	268	268
SPEL	eDrive low-pressure single pump	127	127	147	180	180	180
DPEL	eDrive low-pressure twin pump	177	177	250	250	250	250
SPEH	eDrive high-pressure single pump	136	136	152	211	211	211
DPEH	eDrive high-pressure twin pump	205	205	299	309	309	309

## HEAT PUMP UNITS

Option	Hydraulic module	220D	250D	280D	300D	350D	370D	400D	450D
SPLP	Low-pressure single pump	117	117	134	134	134	170	170	170
DPLP	Low-pressure twin pump	167	167	239	239	239	239	239	239
SPHP	High-pressure single pump	126	126	139	139	139	174	174	184
DPHP	High-pressure twin pump	195	195	284	284	284	268	268	279
SPEL	eDrive low-pressure single pump	127	127	147	147	147	180	180	180
DPEL	eDrive low-pressure twin pump	177	177	250	250	250	250	250	250
SPEH	eDrive high-pressure single pump	136	136	152	152	152	211	211	211
DPEH	eDrive high-pressure twin pump	205	205	299	299	299	309	309	320

## DESUPERHEATER : PARTIAL HEAT RECOVERY

On eCOMFORT units from 220 to 400 kW, an additional plate heat exchanger (water / refrigerant) on each circuit allows a 20 to 25% recovery of the heat rejected. This heat exchanger is sized to recover heat for the production of free hot water up to 70 °C. Typical applications for heat recovery are installations with high demand for hot water :

- for domestic use, such as hospitals and hotels
- for industrial use.

This option is available on both cooling only and heat pump versions. Heat recovery can only be applied when the unit is operating (either in cooling or in heating mode).

GAC with Desuperheater option		GAC 220	GAC 250	GAC 300	GAC 330	GAC 370	GAC 400
Cooling capacity (at 12/7°C with 35°C ambient)	kW	213.8	250	292.5	326.8	362.2	405.6
Heat recovery capacity (at 50/60°C)		48.4	60.6	79.2	89.1	98.5	102
Water flow	m <sup>3</sup> /h	4.17	5.23	6.83	7.68	8.5	8.8
Exchanger pressure drop	kPa	14.1	21.6	36	21.5	26.1	27.8
Water volume	dm <sup>3</sup>	4.2			6.3		
Connection diameters	inch	2" 1/2					

Conditions :

Unit :

Water inlet / outlet temperature = 12 °C / 7 °C  
Outdoor air temperature = 35 °C (glycol 0%)

Desuperheater :

Water inlet / outlet temperature = 50 °C / 60 °C

## DESUPERHEATER : OPERATING LIMITS

Minimum outlet water temperature	°C	25
Maximum outlet water temperature		70
Minimum difference water inlet / outlet		3
Maximum difference water inlet / outlet		15

If the water inlet temperature is lower than 25°C, a three-way valve is required.

## SOUND POWER LEVEL - STANDARD UNITS WITH STANDARD COMPRESSORS - FULL LOAD OPERATION

	Size	Spectrum per octave band (dB)								Global sound power Lw dB(A)
		63 Hz	125 Hz	250 Hz	500 Hz	1000 Hz	2000 Hz	4000 Hz	8000 Hz	
Standard version	GAC220DP2M	61.6	73.4	79.2	84.7	86.3	84.2	78.5	72.5	90.6
	GAC250DP2M	64.0	76.0	81.5	86.5	88.1	85.5	79.6	74.8	92.3
	GAC300DP2M	64.0	76.0	81.1	86.6	87.2	86.4	79.7	75.0	92.3
	GAC330DP2M	62.3	73.8	79.8	86.7	87.6	86.0	79.6	74.8	92.1
	GAC370DP2M	62.3	73.8	79.4	86.8	86.9	86.7	79.8	75.0	92.1
	GAC400DP2M	65.8	77.8	82.9	89.0	88.8	89.8	81.3	76.6	94.6
Fix speed AC fan (option SFAC)	GAC220DP2M	57.2	65.3	75.8	83.6	85.2	83.5	77.6	75.2	89.2
	GAC250DP2M	57.3	67.6	77.7	85.4	86.8	84.4	78.7	77.4	90.6
	GAC300DP2M	57.3	67.6	77	85.5	85.5	85.6	78.8	77.6	90.6
	GAC330DP2M	59	68	78	86.2	87.2	85.8	79.4	78	92.1
	GAC370DP2M	58.9	65.9	75.5	85.9	85.9	86.2	78.8	76.9	91.1

## SOUND POWER LEVEL - LOW NOISE UNITS WITH ACOUSTIC ENCLOSURE (LNCJ) WITH STANDARD COMPRESSORS - FULL LOAD OPERATION

	Size	Spectrum per octave band (dB)								Global sound power Lw dB(A)
		63 Hz	125 Hz	250 Hz	500 Hz	1000 Hz	2000 Hz	4000 Hz	8000 Hz	
Standard version	GAC220DP2M	61.6	73.4	78.8	82.3	83.8	80.9	75.8	69.1	88.2
	GAC250DP2M	64.0	76.0	81.1	84.2	85.8	82.8	77.4	71.6	90.2
	GAC300DP2M	64.0	76.0	81.0	84.2	85.5	83.1	77.4	71.6	90.2
	GAC330DP2M	62.3	73.8	79.4	83.6	84.7	82.0	76.7	70.1	89.2
	GAC370DP2M	62.3	73.8	79.3	83.7	84.4	82.3	76.8	70.1	89.1
	GAC400DP2M	65.8	77.8	82.8	86.3	87.3	85.5	79.2	73.4	92.1
Fix speed AC fan (SFAC)	GAC220DP2M	57.2	65.3	74.8	80	81.7	79.1	73.9	73.7	85.6
	GAC250DP2M	57.3	67.6	77	82	83.3	80.5	75.8	76	87.2
	GAC300DP2M	57.3	67.6	76.7	82	82.8	81	75.9	76	87.2
	GAC330DP2M	59	68	77.3	82.7	83.9	81.4	76.3	76.3	89.1
	GAC370DP2M	58.9	65.9	75.1	81.7	82.4	80.9	74.7	74.4	86.8

## STANDARD SOUND LEVEL

	Size	Spectrum per octave band (dB)								Global sound power Lw dB(A)
		63 Hz	125 Hz	250 Hz	500 Hz	1000 Hz	2000 Hz	4000 Hz	8000 Hz	
Standard version	GAH220DP2M	64	76	81.4	85.7	87.4	85.2	79.5	73.7	91.8
	GAH250DP2M	64	76	81.5	86.5	88.1	85.5	79.6	74.8	92.3
	GAH280DP2M	62.2	73.8	79.6	86.1	86.9	85.5	79.2	74.2	91.5
	GAH300DP2M	62.3	73.8	80	86.7	88.1	85.5	79.6	74.7	92
	GAH350DP2M	65.8	77.8	83	87.9	89	87.4	81.1	76.2	93.7
	GAH370DP2M	59.1	69	77.8	86.8	88	85.5	79.6	74.6	91.8
	GAH400DP2M	64.6	76.4	82	88	89	87.4	81.1	76.2	93.5
	GAH450DP2M	67	79	84.1	89	89.8	88.7	82.2	77.3	94.7
Fix speed AC fan (option SFAC)	GAH220DP2M	59.1	69.4	79.1	85	86.6	84.7	79.5	78.3	90.7
	GAH250DP2M	59.1	69.4	79.2	86	87.4	85	79.6	78.7	91.3
	GAH280DP2M	59.6	67.3	77.1	85.4	86.3	85.1	78.7	77.3	90.7
	GAH300DP2M	59.6	67.3	77.8	86.1	87.6	85.1	79.2	77.6	91.3
	GAH350DP2M	60.9	71.2	80.6	87.3	88.2	86.9	81.1	80.4	92.7
	GAH370DP2M	60.1	63.1	75.6	86.2	87.8	85.3	78.6	75.8	91.4
	GAH400DP2M	61.2	69.9	79.6	87.4	88.3	87	80.8	79.6	92.6
	GAH450DP2M	62.1	72.4	81.6	88.3	88.8	88.3	82.2	81.6	93.6

Global sound power level measured in compliance with ISO standard 3744 and according Eurovent standards.

## STANDARD SOUND LEVEL WITH ACOUSTIC ENCLOSURE (LNCJ)

	Size	Spectrum per octave band (dB)								Global sound power Lw dB(A)
		63 Hz	125 Hz	250 Hz	500 Hz	1000 Hz	2000 Hz	4000 Hz	8000 Hz	
Standard version	GAH220DP2M	64	76	81.1	83.8	85.6	82.7	77.4	71.4	90.1
	GAH250DP2M	64	76	81.1	84.2	85.8	82.8	77.4	71.6	90.2
	GAH280DP2M	62.2	73.8	79.3	83.3	84.4	81.8	76.6	69.9	89
	GAH300DP2M	65.8	77.8	82.9	85.8	87.3	84.6	79.2	73.3	91.9
	GAH350DP2M	65.8	77.8	82.9	85.8	87.3	84.6	79.2	73.3	91.9
	GAH370DP2M	59.1	69	76.7	82.9	83.5	80.4	75.9	67.6	87.7
	GAH400DP2M	64.6	76.4	81.7	85.4	86.6	83.9	78.7	72.3	91.2
	GAH450DP2M	67	79	84	87	88.4	85.8	80.3	74.5	93.1
Fix speed AC fan (option SFAC)	GAH220DP2M	59.1	69.4	78.6	82.7	84.3	81.8	77.4	77.7	88.4
	GAH250DP2M	59.1	69.4	78.7	83.2	84.6	81.9	77.4	77.7	88.6
	GAH280DP2M	59.6	67.3	76.6	82	83.3	81	75.7	75.7	87.4
	GAH300DP2M	59.6	67.3	76.8	82.4	83.9	81	75.8	75.8	87.7
	GAH350DP2M	60.9	71.2	80.3	84.7	86.1	83.7	79.2	79.5	90.2
	GAH370DP2M	60.1	63	73.5	81.3	83	79.8	73	71.8	86.6
	GAH400DP2M	61.2	69.9	79.1	84.2	85.5	83.1	78.1	78.3	89.6
	GAH450DP2M	62.1	72.4	81.5	85.9	87.1	85	80.3	80.7	91.3

Global sound power level measured in compliance with ISO standard 3744 and according Eurovent standards.

COOLING ONLY UNIT



**WARNING**

It is very important to ensure that the units operate well inside these envelopes.

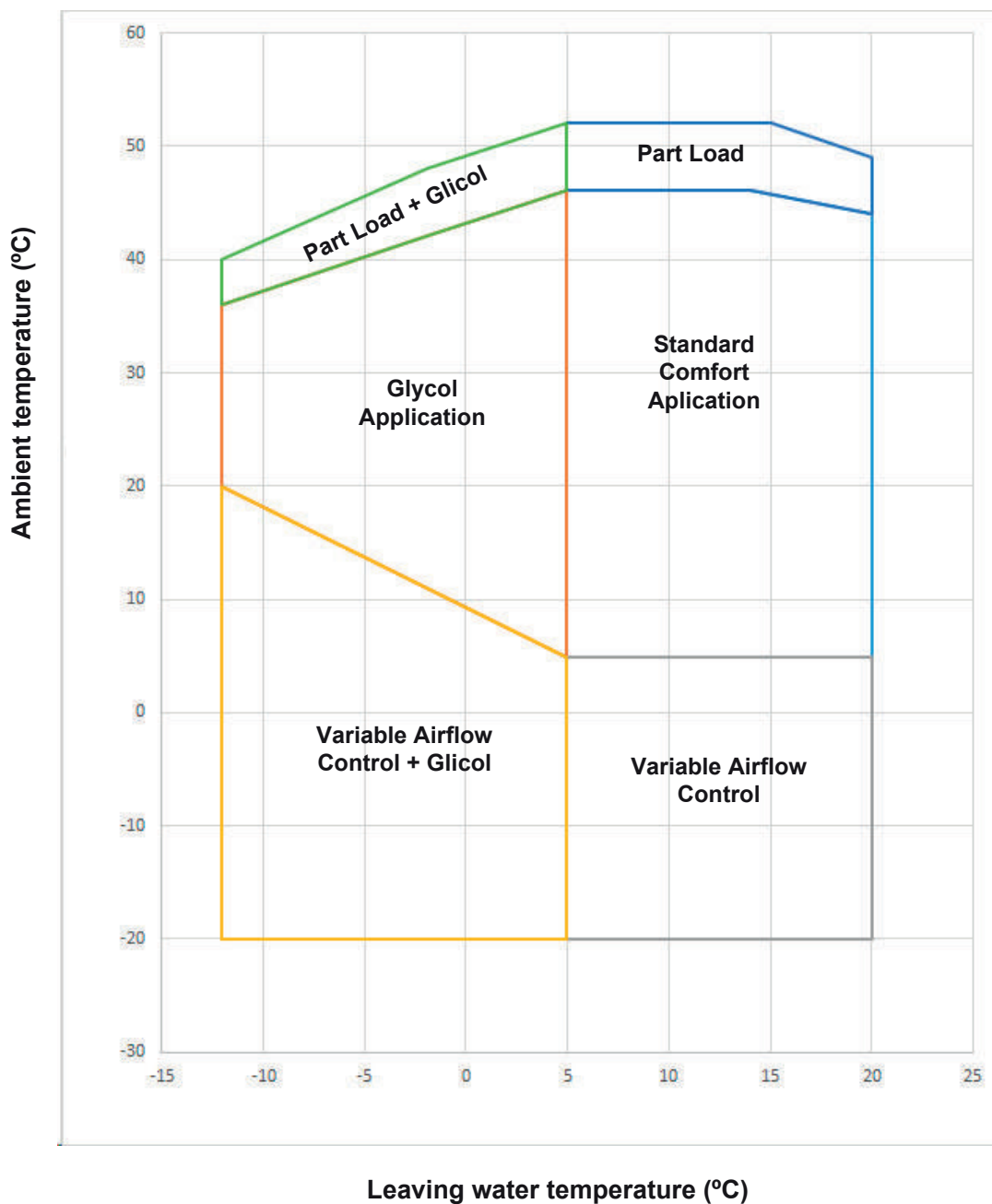

HEAT PUMP UNIT

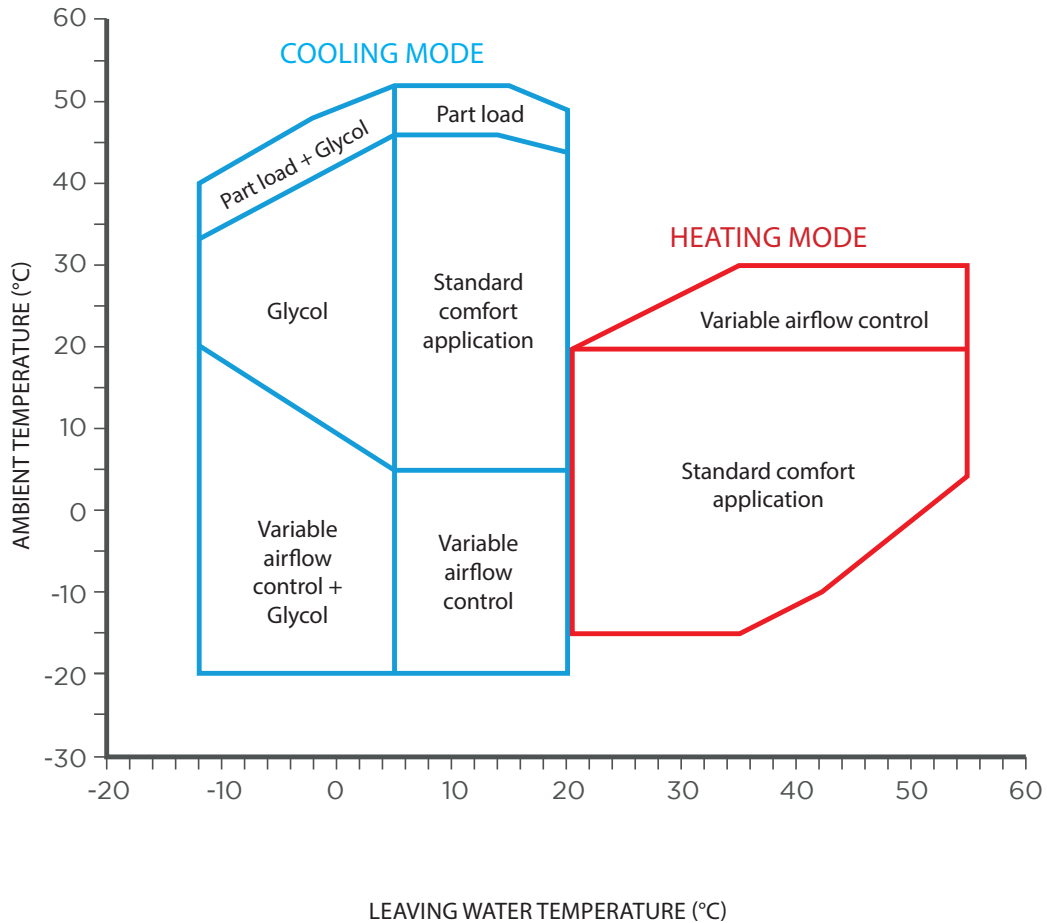

	GAC/GAH Cooling mode		GAH Heating mode	
	minimum	maximum	minimum	maximum
<b>Water outlet temperature</b>				
Standard	5	20	20	55
With low leaving water temperature option (LLWT) + antifreeze option	-12	20	NA	NA
Inlet/outlet temperature difference	3	10	3	10
<b>Air temperature</b>				
Standard unit (variable airflow control or high pressure EC fans (HIPF))	-20°C	46°C	-15°C	30°C
With AC fan option (SFAC)	5°C	46°C	-15°C	20°C

## eCOMFORT R32 - GAC

eCOMFORT R32 - GAC		220D	250D	300D	330D	370D	400D
Maximum power	KW	94,0	108,4	129,2	143,5	159,1	180,8
Maximum current	A	157,3	176,6	211,6	234,2	260,5	296,7
<b>Locked rotor current</b>							
Starting current	A	322,0	327,2	393,5	416,1	442,4	606,6
Starting current with softstarter		278,4	297,7	358,9	381,5	407,8	534,3
<b>AC FAN (SFAC)</b>							
Additional power	KW	0,00	0,00	0,00	0,00	0,00	0,00
Additional current	A	2,9	3,2	3,2	4,2	4,2	4,8
<b>Low pressure water pump (SPLP)</b>							
Additional power	KW	3,50	3,50	5,70	5,70	5,70	5,70
Additional current	A	6,33	6,33	10,50	10,50	10,50	10,50
<b>High pressure water pump (DPLP)</b>							
Additional power	KW	3,40	3,40	5,80	5,80	5,80	5,80
Additional current	A	6,33	6,33	10,50	10,50	10,50	10,50
<b>Antifreeze electrical heater (APEP &amp; APPP)</b>							
Additional power	KW	0,5					
Additional current	A	1,2					

eCOMFORT R32 - GAH		220D	250D	280D	300D	330D	370D	400D	450D
Maximum power	KW	96,05	108,37	118,47	133,04	152,74	157,71	177,41	197,11
Maximum current	A	160,41	176,59	193,87	216,75	249,17	256,91	289,33	321,75
<b>Locked rotor current</b>									
Starting current	A	96,05	108,37	118,47	133,04	152,74	157,71	177,41	197,11
Starting current with softstarter		160,41	176,59	193,87	216,75	249,17	256,91	289,33	321,75
<b>AC FAN (SFAC)</b>									
Additional power	KW	96,05	108,37	118,47	133,04	152,74	157,71	177,41	197,11
Additional current	A	160,41	176,59	193,87	216,75	249,17	256,91	289,33	321,75
<b>Low pressure water pump (SPLP)</b>									
Additional power	KW	3,50	3,50	5,70	5,70	5,70	5,70	5,70	7,80
Additional current	A	6,33	6,33	10,50	10,50	10,50	10,50	10,50	14,10
<b>High pressure water pump (DPLP)</b>									
Additional power	KW	3,40	3,40	5,80	5,80	5,80	5,80	5,80	8,20
Additional current	A	6,33	6,33	10,50	10,50	10,50	10,50	10,50	14,10
<b>Antifreeze electrical heater (APEP &amp; APPP)</b>									
Additional power	KW	0,5							
Additional current	A	1,2							

GAC220 DP2M / GAC250 DP2M / GAC300 DP2M

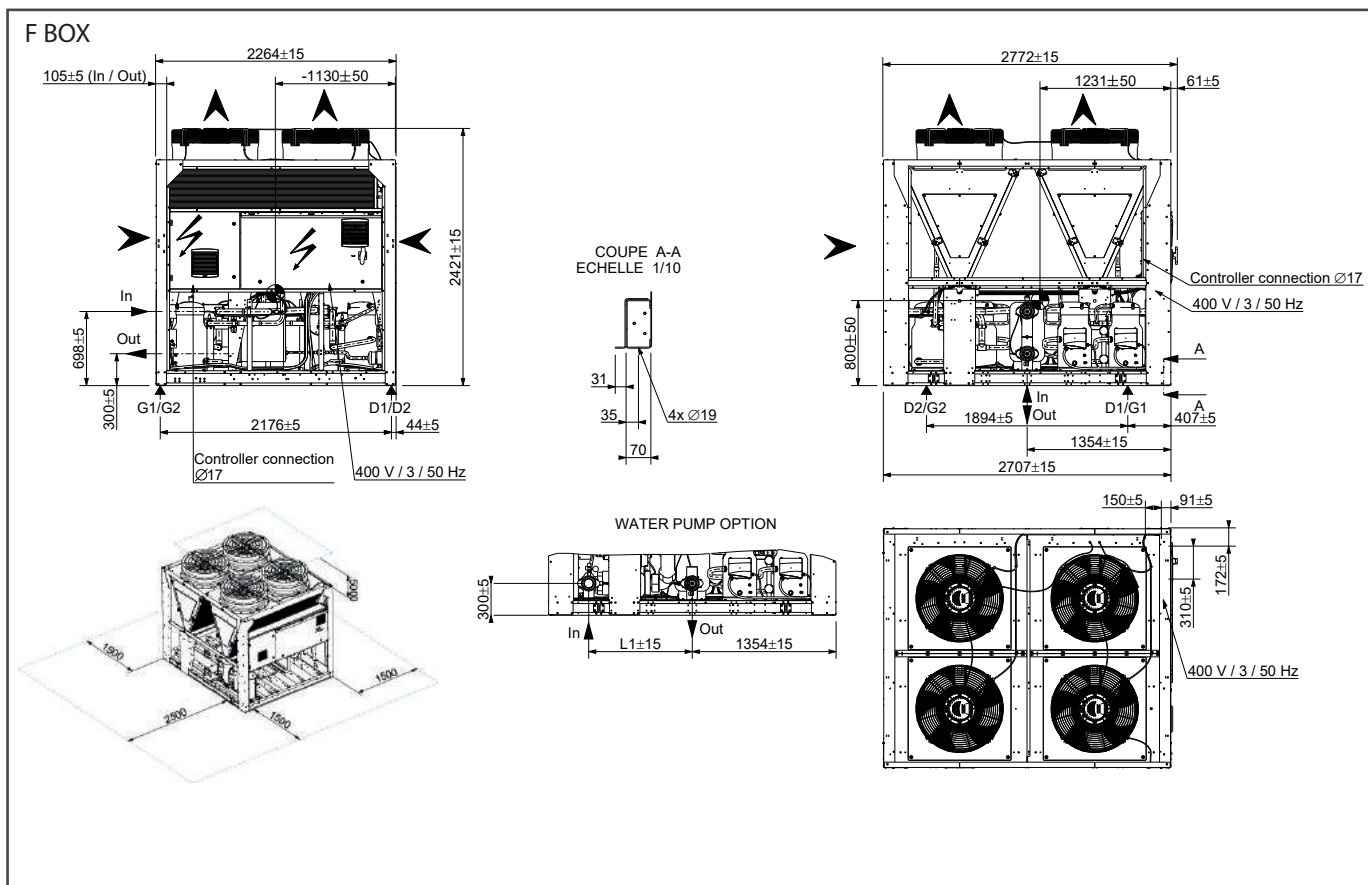

GAC300 DP2M / GAC370 DP2M / GAC400 DP2M

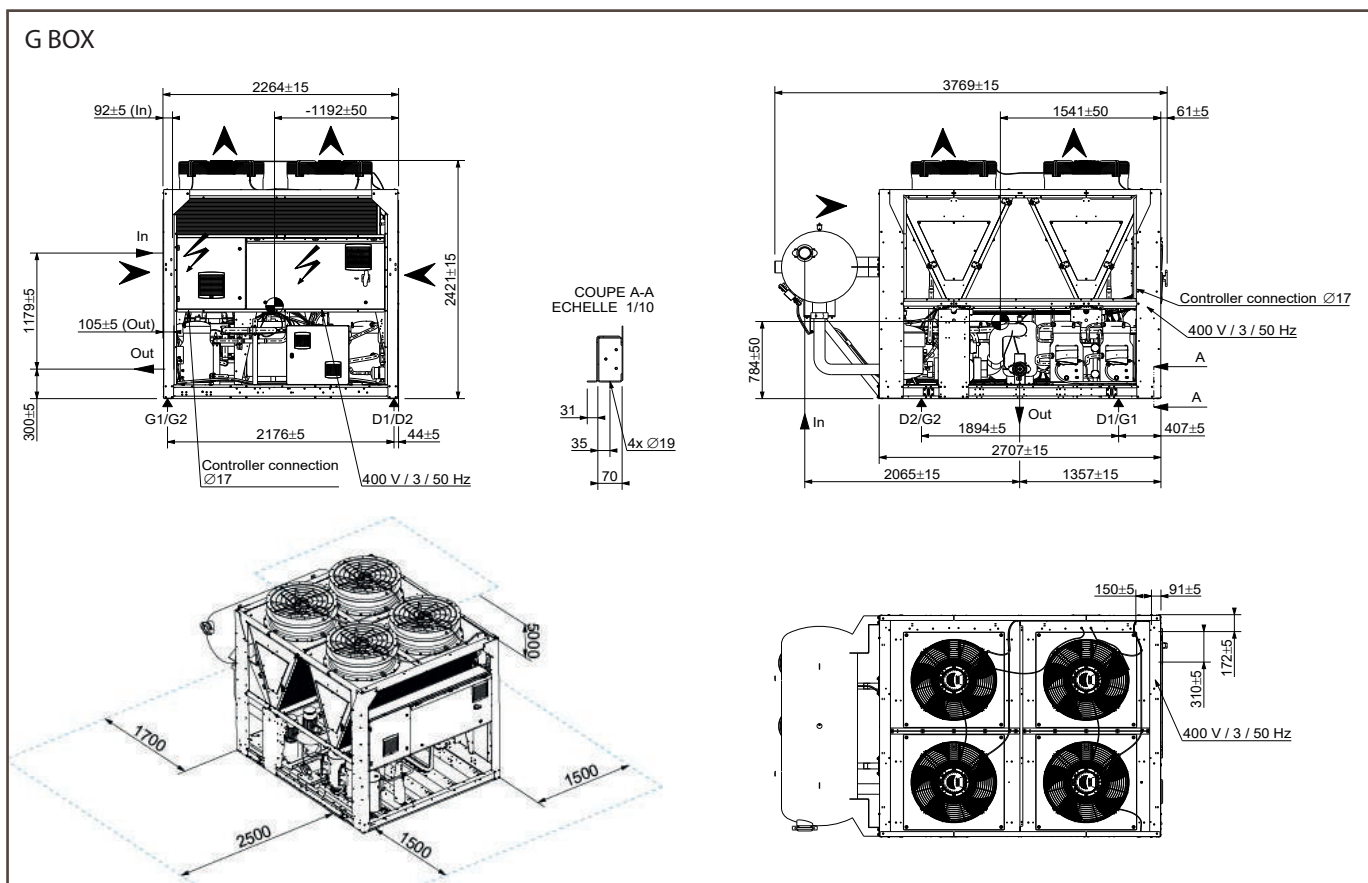

GAH 220DP2M / GAH250 DP2M

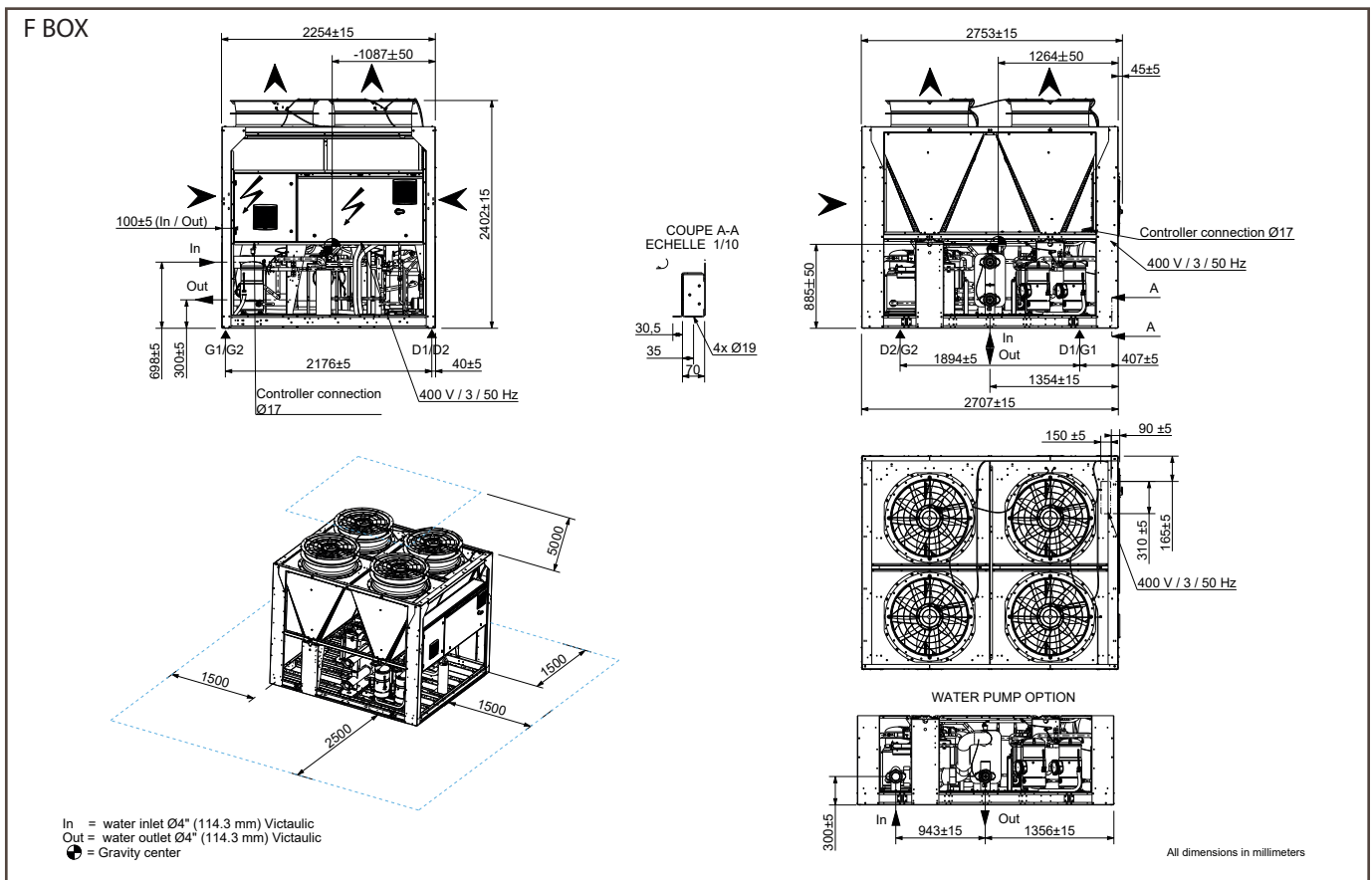

GAH280 DP2M / GAH350 DP2M

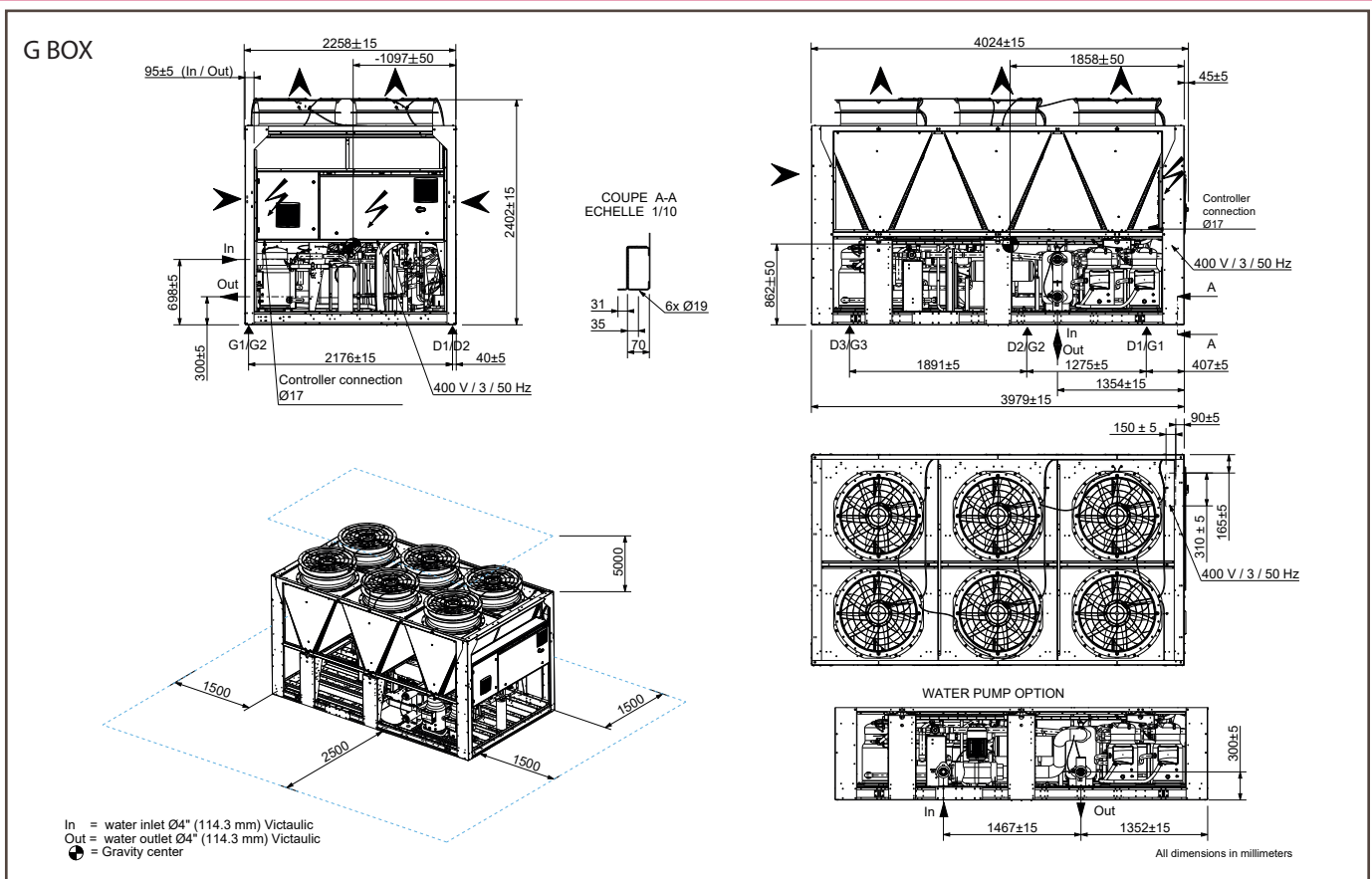

GAH370 DP2M / GAH400 DP2M / GAH450 DP2M

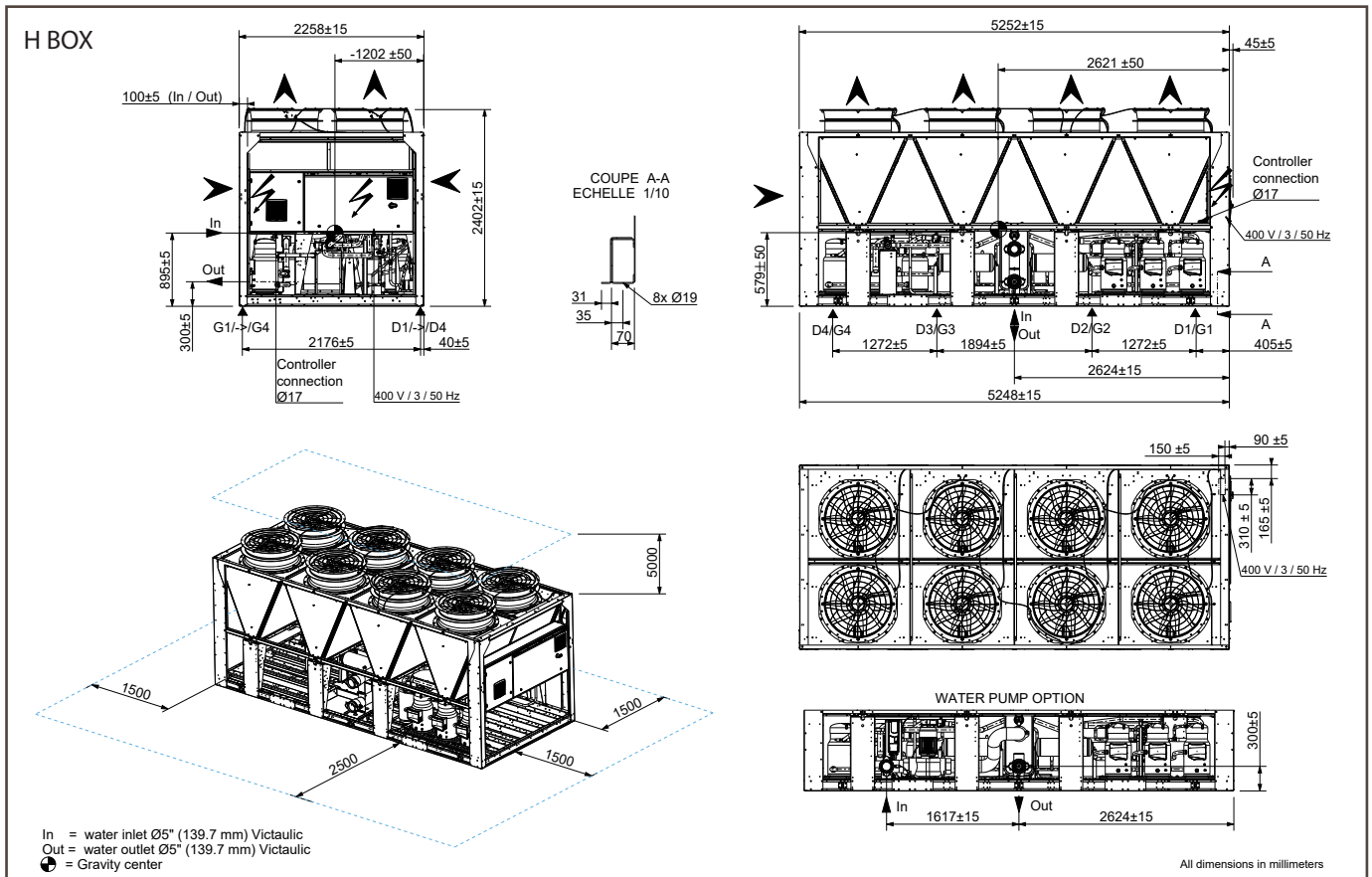



Due to LENNOX EMEA ongoing commitment to quality, the specifications, ratings and dimensions are subject to change without notice and without incurring liability.

Improper installation, adjustment, alteration, service or maintenance can cause property damage or personal injury.

Installation and service must be performed by a qualified installer and servicing agency.



brand of LENNOX EMEA

**Headquarters LENNOX EMEA**

7 rue des Albatros - Z.I. Les Meurières, 69780 Mions - France

+33 (0) 810 502 502

[www.lennoxemea.com](http://www.lennoxemea.com)

