



# eComfort + eComfort Advanced

Air cooled liquid chiller and heat pump

**Application guide**



**eComfort Advanced -AGU-2305-EN**



LENNOX participates in the ECP  
programme for RT.  
Check ongoing validity of certificate :  
[www.eurovent-certification.com](http://www.eurovent-certification.com)

<b>3</b>	<b>GENERAL DESCRIPTION</b>
<b>13</b>	<b>OPTIONS AND ACCESSORIES</b>
<b>19</b>	<b>GENERAL DATA</b>
<b>29</b>	<b>TECHNICAL DATA</b>
<b>35</b>	<b>HYDRAULIC EQUIPMENT</b>
<b>50</b>	<b>PARTIAL HEAT RECOVERY</b>
<b>52</b>	<b>SOUND POWER LEVEL</b>
<b>54</b>	<b>OPERATING LIMITS</b>
<b>55</b>	<b>ELECTRICAL DATA</b>
<b>59</b>	<b>DIMENSIONAL DATA</b>



Product designed and manufactured under :

- Quality management system: ISO 9001
- Environmental management system: ISO 14001.
- Occupational health and safety management systems : OHSAS 18001



[www.eurovent-certification.com](http://www.eurovent-certification.com)  
[www.certiflash.com](http://www.certiflash.com)



Our company's products comply with European standards

All the technical and technological information contained in this manual, including any drawing and technical descriptions provided by us, remain the property of Lennox and must not be utilised (except in operation of this product), reproduced, issued to or made available to third parties without the prior written agreement of Lennox.

\*For out of EEC countries, non CE marked, and non EUROVENT certified units are available on request, please consult us.



## THE EXPERIENCE & COMMITMENT OF THE EUROPEAN LEADER TO DRIVE CONTINUOUS ENERGY SAVINGS

Lennox contribution to combat rising energy costs and global warming is to design innovative, efficient and dependable products, while providing best comfort and air quality.

As a major player in the European HVAC market, Lennox is a reference in sustainable development and has been assembling its products in ISO-14001 certified factories since 2007.

The eCOMFORT complete range is Eurovent certified.

## APPLICATION

The eCOMFORT range is perfect for air conditioning applications in tertiary and commercial buildings such as offices, hotels, shops and restaurants as well as for cooling processes in, for example, industrial, medical, food, winemaking and data centre environments.



## LOWER ENERGY BILLS

The eCOMFORT water chillers and heat pumps have been optimized so you don't need to worry about your energy bill.

In thermal comfort applications, 80% of the operating times are between -2 and 10°C outside air in heating mode and 17 and 26°C in cooling mode.

The eCOMFORT units have been optimized primarily for these partial load operating conditions.

The eCOMFORT range therefore offers seasonal energy efficiencies (SEER & SCOP) that exceed the European ecodesign requirements for 2021 (cooling mode) and 2017 (heating mode).

These seasonal energy efficiencies refer to the ratio between the annual requirements of buildings in cooling or heating and the annual electricity consumption. The high seasonal energy efficiencies of the eCOMFORT range help reduce your energy bill by 12% to 15% on average compared to a traditional unit and, therefore, facilitate a rapid return on investment.

The scenario is similar in industrial cooling applications, where 90% of the operating times are between -2°C and 25°C outside air.

The eCOMFORT units, in conjunction with variable air flow control, ensure the best SEPR seasonal energy efficiencies, which exceed the European requirements for 2021 regarding high-temperature process cooling (7°C outlet water temperature) and for 2018 regarding medium temperature process cooling (-8°C outlet water temperature).



## F-GAS DIRECTIVE RELATED TO THE EU REGULATION NO. 517/2014

It entered in force in January 2015, to contribute to the reduction of the global warming by limiting the use of HFCs.

High GWP refrigerants may have a speculative price increase after each quota, due to the reduced availability of bulk HFC on the market.

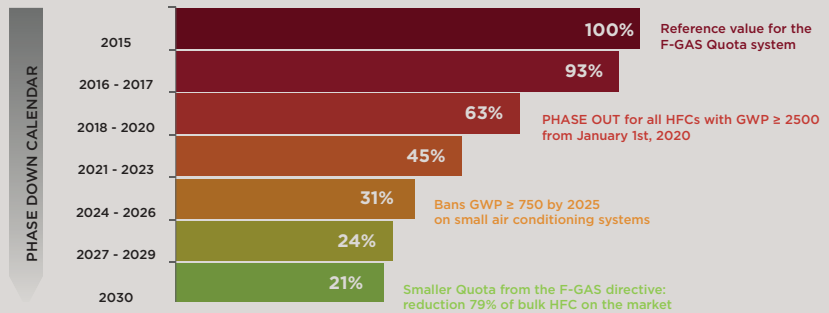

## REFRIGERANT SAFETY CLASS: R32

A2L refrigerants have a low burning velocity and a low heat of combustion. These characteristics makes them hard to ignite and eliminates the risk of an explosion.

The European standard EN378 classifies R32 as an A2 refrigerant, while ASHRAE Standard 34 classifies it as an A2L. Both regulations define R32 as a mildly flammable gas. However, it is unlikely to start the fire, as a large amount of refrigerant is required to sustain combustion.

A1 eCOMFORT R410a	B1	No flame propagation
A2L eCOMFORT R32	B2L	Lower flammability
A2	B2	Lower flammability
A3	B3	Higher flammability
Higher toxicity	Higher toxicity	

## BENEFITS OF R32

Low charge refrigerant:

- Up to 30% charge reduction on the total thermodynamic circuit

Single component substance:

- No glide
- Easy to handle and recover

Availability:

- Largely applied on the residential market
- Low price and easy to source

ASHRAE safety group: A2L

Composition:

- 100% Difluoromethane (HFC)

## CO<sub>2</sub>e : CARBON DIOXIDE EQUIVALENT

CO<sub>2</sub>e indicates the amount of CO<sub>2</sub> which would have the equivalent global warming impact of any refrigerant.

To limit the use of high GWP refrigerants, many countries have set taxes to be applied on the sale those substances.

The tax is usually proportional to the CO<sub>2</sub>e and to the amount of fluorinated refrigerant used on the system (HFCs).

$$\text{CO}_2\text{e} = \frac{\text{Refrigerant charge (kg)} \times \text{GWP}}{1000}$$

### FRENCH TAXES

Step 1: 15€/CO<sub>2</sub>e

Step 2: 30€/CO<sub>2</sub>e

## ADDITIONAL REFRIGERANT CHARGES

To exemplify one of the benefits of the eCOMFORT over its previous version (eCOMFORT R410a/Ecolean), a comparison between two models with similar capacity presents 74% of savings on the additional refrigerant charges along the unit lifespan.

UNIT	eCOMFORT R410a GAH160DM	eCOMFORT R32 GAH160DP
Refrigerant	R410a	R32
GWP <sup>1</sup>	1924	677
Refrigerant Price <sup>2</sup> (€/kg)	€ 38,00	€ 15,00
Total Refrigerant Charge (kg)	37	27
Leakage Charge per year <sup>3</sup> (kg)	1,85	1,35
Leakage Charge / 10 years (kg)	18,5	13,5
Refrigerant Cost (€/10years)	€ 703	€ 202
Leaked charge during step 1	7,4	5,4
CO <sub>2</sub> e	14,2	3,6
French taxes step 1	€ 213	€ 54
Leaked charge during step 2	11,1	8,1
CO <sub>2</sub> e	21,3	5,4
French taxes step 2	€ 640	€ 162
<b>TOTAL COST</b>	<b>€ 1.556</b>	<b>€ 418</b>

1. GWP values based on the IPCC 5th assessment report
2. Average price for French market (2019)
3. Considering average leakage rate of 5% per year

**74% OF SAVINGS**

## LEAK TEST FREQUENCY

According to F-Gas, the amount of CO<sub>2</sub>e of the total refrigerant charge on a circuit will define how often a leakage test will be required.

A leak test usually takes a technician half day of work on the job site and may cost around 450€/test<sup>1</sup>.

Considering the same units from the previous example, the eCOMFORT can offer 50% of savings on the leak test costs along the unit lifespan.

TeqCO <sub>2</sub>	F-GAS LEAK CHECKING FREQUENCY	
	With no leak detection equipment fitted	With leak detection equipment fitted
TeqCO <sub>2</sub> ≤ 5	None	None
5 < TeqCO <sub>2</sub> ≤ 50	once every 12 months	once every 24 months
50 < TeqCO <sub>2</sub> ≤ 500	once every 6 months	once every 12 months
TeqCO <sub>2</sub> ≥ 500	once every 3 months	once every 6 months

UNIT	eCOMFORT R410a GAH160DM	eCOMFORT R32 GAH160DP
Refrigerant	R410a	R32
GWP <sup>2</sup>	1924	677
Refrigerant Charge per circuit (kg)	18.5 / 18.5	13.5 / 13.5
CO <sub>2</sub> e per circuit	35.6 / 35.6	9.1 / 9.1
Leak detection equipment	Optional feature	Optional feature
Leak test frequency on each circuit	once every 12 months	once every 24 months
Leak tests along 10 years of lifespan	20 (10 on each circuit)	10 (5 on each circuit)
Leak test cost (€/test) <sup>1</sup>	450 €/test	450 €/test
<b>TOTAL COST</b>	<b>€ 9.000</b>	<b>€ 4.500</b>

1. The leakage test cost may diverge by region
2. GWP values based on the IPCC 5th assessment report

**50% OF SAVINGS**

## G<sub>(A)</sub> A<sub>(B)</sub> C<sub>(C)</sub> 035<sub>(D)</sub> S<sub>(E)</sub> P<sub>(F)</sub> 1<sub>(G)</sub> M<sub>(H)</sub>

- (A) **G** = eComfort
- (B) **A** = Air cooled unit fix compressor - **B** = Air cooled unit advanced version
- (C) **C** = Cooling only unit - **H** = Heat pump unit
- (D) **035** = Approximate power in kW
- (E) **S** = Single circuit - **D** = Double circuit
- (F) **P** = Refrigerant R32
- (G) **1** = Revision number
- (H) **M** = 400V/3/50Hz

## KEY FEATURES

- Fast and easy installation and commissioning thanks to the integration of a complete hydraulic module with buffer tank and immersed heating rods.
- Compact and discreet design for perfect architectural integration.
- Excellent SEPR and SCOP seasonal energy efficiencies, which exceed the European EcoDesign 2021 requirements.
- Precise water temperature control in cooling and heating modes thanks to highly efficient components.

## ECODESIGN 2021



### eDrive

Variable speed pump allowing capacity modulation.



### Desuperheater

Free hot water production for sanitary or industrial purposes.



### Highly efficiency compressors

Multi-scroll compressors, mounted in tandem or trio, and variable speed compressor, allowing capacity modulation.

## RANGE PRESENTATION

### STRAIGHTFORWARD INSTALLATION

Installation and commissioning are fast and easy since the following features are integrated in the unit:



Complete hydraulic module with low or high-pressure single or twin pump, comprising pump(s), expansion tank with pressure gage and safety valve, pressure taps, water filter with sieve, air bleed and water flow controller.

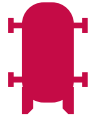

Large-capacity buffer tank (100 to 325 litres of water depending on the size of the unit), providing sizable energy storage and a buffer effect of approximately 2.7 litres/kW on average across the entire range.



Immersion heating rods, medium or high-power modulating auxiliary electric heating elements incorporated directly in a buffer tank inside the unit.

Only electric and hydraulic connections are required for the eCOMFORT unit.

Furthermore, the eCOMFORT range is compact and discreet for perfect architectural integration. Low profile, the equipped with AC fans does not exceed 1.5 to 1.7 m and all the cooling and hydraulic components are concealed within the unit.

### USER COMFORT THROUGHOUT THE YEAR

With extended operating ranges, the eCOMFORT range has been designed to guarantee thermal comfort throughout the year.

- In heating mode, the eCOMFORT range produces hot water at 42°C up to an outdoor temperature of -10°C: thermal comfort is maintained throughout the winter. Furthermore, the unit works in extreme cold, right down to -15°C, and the heating rods ensure thermal comfort is always maintained and guaranteed. Medium- or high-power modulating auxiliary electric heating elements are incorporated in a buffer tank inside the unit.
- In cooling mode, the unit works at full load from -20°C to 46°C ambient air. In addition, it can work at partial load up to ambiances reaching 52°C. For industrial applications, the outlet water temperature can go as low as -12°C.
- The eCOMFORT units offer precise control of the outlet water temperature in cooling and heating modes thanks to multistage scroll compressors in conjunction with an electronic expansion valve and a large-capacity buffer tank. In addition, this water tank ensures sizable energy storage. Its buffer effect eliminates the constraints of high variable load systems and the inconvenience associated with the defrost phases for heat pumps.

### ACOUSTIC COMFORT

- The eCOMFORT range has different noise levels, meeting all external constraints.
- The eCOMFORT units offer quiet operation as standard thanks to:
  - The use of optimized components with small, silent compressors and high-performance propeller fans with profiled blades, producing a significant reduction in the noise level.
  - A compact design with compressors, pumps and fans inside a closed box.
- This range also offers a second effective noise level with integration of the optional, high-performance acoustic cover, which can halve the noise of the unit (-3 dBA).
- Furthermore, the eCOMFORT range has an intelligent noise attenuation system called the Active Acoustic Attenuation System. Combined with the variable air flow controller (available on standard units - EC fan), this system automatically adjusts the air flow to remain within the daytime and night-time noise level constraints (programmable) while guaranteeing thermal comfort within the building. (Not available with the optional SFAC - AC fan)

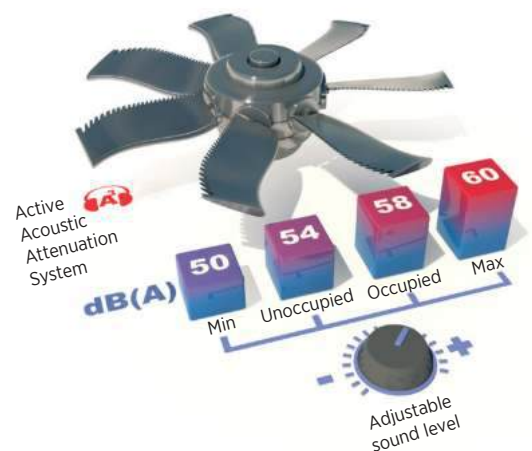

## 3 SILENT MODES AVAILABLE:

### PERFORMANCE MODE

1. The fan starts in low speed to maintain a minimum condensing pressure
2. The fan will switch to high speed to optimize the performance and energy consumption based on the condensing temperature (around 30°C outside air)

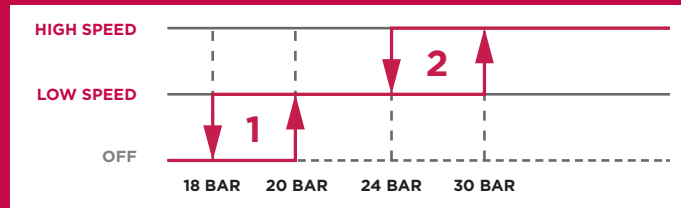

### QUIET MODE

1. The fan operates in low speed to achieve a low noise
2. The fan will switch to high speed only if the maximum condensing pressure is reached (around 40°C outside air)

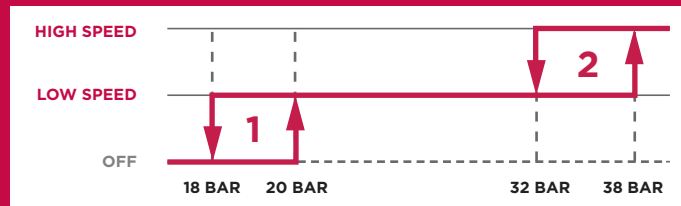

### QUIET++ MODE<sup>1</sup>

1. The fan operates in low speed to achieve a low noise
2. The fan will never switch to high speed and a compressor will be unloaded if the maximum condensing pressure is reached

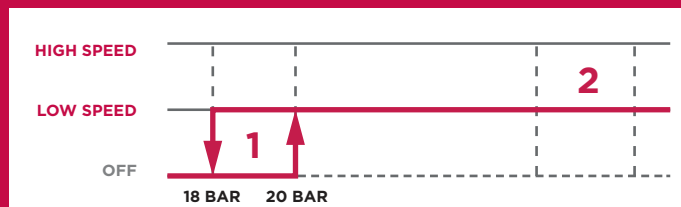

## ECOMFORT WITH TOTAL MODULATION

The eCOMFORT Advanced range benefits from the latest technologies to achieve very high seasonal efficiencies of over 195% / 4.94 (η<sub>s, c</sub> / SEER) for cooling applications and over 3.9 (SCOP) for heating applications.

These technologies provide total modulation of the unit with control and flow variation of:

- refrigerant : thanks to a very high efficiency variable speed compressor with permanent magnet motor,
- air : with high-efficiency EC fans with "Owlet" type blades and high performance integrated diffusers to improve airflow efficiency,
- water : thanks to the variable speed inverter of the water pump.

Moreover, thanks to the variable speed technology on the compressor part, the cooling demand is precisely adapted to the needs of the application. The control of the water outlet temperature is perfect as for example: 7°C +/- 0.5°C in case of fast variable thermal load or for example: 7°C +/- 0.1°C in case of slow variable thermal load.

In addition, buffer tank requirements in case of low water volume or rapid variable heat load are reduced.



1. QUIET++ MODE: The unit operating limits are reduced (around 42°C of max outside air temp.)

## TECHNICAL DESCRIPTION

### CONNECTIVITY FOR COMFORT

LennoxHydrocontrol is a user-friendly interface for local supervision of the entire hydraulic system. It guarantees constant comfort throughout the year and saves energy thanks to:

- zoning of the building,
- time programming by zone,
- precise control of setpoints by zone,



### CONNECTIVITY FOR PERFORMANCE

LennoxCloud facilitates remote monitoring of the unit, making it possible to achieve significant energy savings while avoiding performance drifts throughout the unit's life cycle. The eComfort units can be remotely controlled, adjusted and diagnosed:

- through online verification of all unit data trends,
- through optimization of unit operation by analysing this data,
- by facilitating maintenance thanks to alarm and alert reports.

Also, LennoxCloud is a single system able to supervise several units located on different installations.



### CONSTRUCTION OF THE UNIT, CASING AND BASE FRAME

The eCOMFORT range complies with the standards and directives of the European Community. All the eCOMFORT units are designed and manufactured according to an ISO 9001 quality and ISO 14001 environmental management system.

The casing and the base frame are in painted or pre-lacquered galvanized steel, guaranteeing **high corrosion resistance**. The casing is white in color (RAL 9003) with red uprights (RAL3003) and the base frame is gray (RAL7016). The design is **modern, compact and discreet**. The cooling components, fans and the entire hydraulic module are concealed for perfect architectural integration.

The **unit height is optimized** (1.5 to 1.7 m with SFAC option) for discreet installation on a roof or on the ground without the need for a peripheral screen.

### COMPRESSORS

The standard units are equipped with **R32 compatible multi-scroll compressors, mounted in single (only for the advanced version) tandem or trio**, to provide the best seasonal efficiencies (ESEER, SEER, SCOP and SEPR) and acoustic noise level.

The Compliance® scroll compressors are of simple and robust design, thus increasing their reliability and service life thanks to:

- axial and radial play, which allows the compressor to tolerate the liquid slugging,
- motor winding cooled by the gas intake,
- electronic control of the compressor discharge temperature,
- a device to protect the motor against overcurrent and overheating, based on size,
- a non-return valve on the discharge,
- an oil equalization sight glass,
- mounting on an independent base frame insulated by anti-vibration pads.



### WATER HEAT EXCHANGER

The evaporator on the eCOMFORT unit is of the latest generation of heat exchangers made from stainless steel plates with copper brazing.

These exchangers **improve the seasonal efficiencies and reduce internal pressure drops**.

They are thermally insulated and frost-protected:

- either through the use of glycol,
- or through activation of the pump managed by the control system,
- or through optional electric tracing.



## AIR HEAT EXCHANGER

As standard, the eCOMFORT cooling only water chillers are equipped with all-aluminum microchannel condenser coils which provide:

- a **significant improvement in efficiency**,
- a **60% reduction** in the amount of refrigerant required,
- **better corrosion resistance**, especially in moderate urban or coastal environments.

The eCOMFORT heat pumps are themselves equipped with traditional condenser coils made from copper tubing and aluminum fins.

All the coils can given an optional anti-corrosion treatment for resistance against highly aggressive environments.

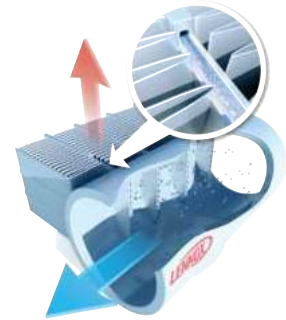

## FANS

As standard, the unit is equipped with latest-generation, high performance propeller fans with profiled blades. The aerodynamic shape of the blades is optimized, **reducing the noise level considerably** while significantly increasing the efficiency compared to conventional blades. These high-performance propeller fans are equipped with EC (electronic commutation) technology, allowing the variable air flow rate to be controlled.

As an option, these high-performance propeller fans can be equipped with AC (alternating current) technology.

All the electric fan motors are class F and are protected against overheating by internal thermal protection as well as IP55 protection.

## REFRIGERATION CIRCUIT

The eCOMFORT range has 1 or 2 independent refrigeration circuits using R32 refrigerant.

Each refrigeration circuit includes:

- the required amount of refrigerant, which is 60% less thanks to the use of R32 refrigerant and microchannel heat exchangers (only on the cool-only version), and 30% less thanks to R32 refrigerant and new coils design.
- a dehydration filter with filter cartridge,
- an electronic expansion valve
- temperature and pressure sensors,
- a high-pressure safety switch.
- a fluid reservoir, a cycle reversing valve and a liquid/vapor exchanger (heat pump version only).



## ELECTRICAL CABINET

- Electrical cabinet, components and cabling compliant with the EN 60204-1 standard.
- 400 V three-phase power supply, 50 Hz, + earth without neutral.
- Power cable inlet is in the lower part of the cabinet.
- IP54 tightness class.
- Electric components are of an international brand to facilitate maintenance and ensure fast replacement.
- Main on/off switch mounted on the front.
- Customer display accessible on the front.
- 400/24 V transformer for control circuit power supply.
- Electrical cables numbered to facilitate maintenance and diagnostic operations.
- Frequency converters (VFD) for controlling the pump with enhanced ventilation (optional eDrive).

## REGULATION

The eCOMFORT range is equipped with the latest generation eCLIMATIC controller.

The eCLIMATIC control system is designed to offer the best seasonal energy efficiencies throughout the unit's service life while ensuring reliable operation, with user-friendly interfaces.

This control system offers numerous possibilities. The main functions are as follows:

- 7 programmable time periods a day, 7 days a week, making it possible to manage the energy savings and the noise level according to the environmental constraints and the constraints on usage of the premises. There are 4 operating modes to choose from,



- Dynamic management of the setpoints: water logic based on outdoor temperature. This control system automatically adjusts the outlet water temperature setpoint based on the cooling (floating LP) or heating requirement and the outdoor temperature,
- Controlling the variable-speed pumps with maintenance of constant delta P, constant delta T or fixed speed/ dead zone control, guaranteeing a reduction in the annual energy consumption related to pumping,
- Control of the bypass valve (if this option is chosen) in constant delta P regulation,
- Intelligent management of the noise level by controlling the variable air flow of the fans,
- Management of compressor and pump run-time balancing and automatic changeover in the event of a pump fault (if twin pump option is chosen),
- Dynamic, intelligent and independent defrost system for each circuit, limiting the number and duration of defrost cycles in winter to ensure high seasonal energy performance (SCOP) in heating mode,
- Automatic unloading of a compressor in case of excessive condensation pressure, allowing the machine to operate even when outside air temperature is high, (operation up to 52°C ambience in partial load),
- Control and protection of all operating ranges,
- Management and regulation of several master/slave units (cascade, takeover),
- Automatic summer/winter changeover.

The eCLIMATIC control system offers an interface on the front, the “DC Advanced” display, equipped with a graphic screen providing access to the main user parameters:

- Reading the variables: temperatures of ambient air, water and refrigerant,
- Reading the refrigerant pressures,
- Reading and programming the operating times and modes,
- Reading and programming the water temperature setpoints,
- Reading and programming the noise level setpoints,
- Alarm history.



## COMMUNICATION

The eCLIMATIC control system is equipped as standard with a GTC port enabling remote control via a communication bus.

Depending on the desired communication protocol, the eCLIMATIC control system can be equipped with an optional ModBUS® communication card.

The control system allows remote control of the unit as standard via programmable dry contacts (2 inputs/1 output). These dry contacts are by default:

- One input: on/off,
- Another configurable input (e.g. summer/winter changeover),
- An output for alarm reports or information.

## STANDARDS: OVERVIEW

The unit is manufactured in compliance with the European standards and directives:

- Pressure equipment, 2014/68/EU,
- Machinery Directive 2006/42/EC,
- Low voltage, 2014/35/EU,
- Electromagnetic compatibility, 2014/30/EU,
- Environment and safety, EN 378-2,
- Use of certain hazardous substances (ROHS), 2011/65/EU,
- Energy-related products: ecodesign, 2009/125/EC,
- WEEE, 2012/19/EU.

LENNOX CLOUD

Lennox cloud is the best tool to remotely monitor and manage all your rooftop and chiller units, independent of their location and condition.



It allows you to monitor and control all units on the same place, from any web browser. Remotely adjust set points from any installation site through a friendly and self-explanatory layout. Lennox Cloud grants you access to alarm history and dashboards with real-time system performance and energy consumption<sup>1</sup> from the entire installation site or from individual units.

WEBVIEW

Remote adjust of system setpoints:

1. Inlet water temperature;
2. Outlet water temperature;
3. Alarm indication;
4. System ON or OFF button;
5. External temperature;
6. Adjust set points;
7. Adjust settings;
8. Adjust time schedule;
9. System mode status:

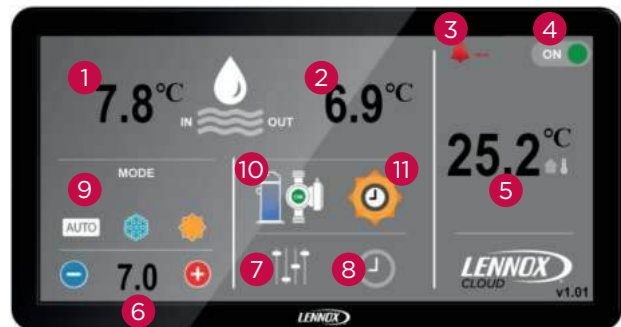

AUTO

Auto mode

Lock:  
Only cool

Lock:  
Only heat

10. Compressor and pump

Pump off

Pump off  
Heat

Pump off  
Cool

Pump on

Pump on  
Heat

Pump on  
Cool

11. Time schedule status

BMS mode (building  
management system)

Day 2 mode

Day 1 mode

Daytime  
operation

Night operation

1. Require Electric Energy Meter - optional feature

<b>LNCJ</b>	Low noise: rigid acoustic compressors enclosure	<b>APEP</b>	Antifreeze protection on exchangers and pipings down to -20°C
<b>SFAC</b>	Fix speed standard AC fans	<b>APPP</b>	Antifreeze protection on exchangers, pipings,pump(s) down to -20°C
<b>HIFP</b>	Variable air flow control with high pressure EC fans	<b>APPW</b>	"Antifreeze protection on exchangers, pump(s) piping and water tank down to -20°C"
<b>ACTR</b>	LenGuard anti-corrosion condenser coil treatment	<b>CGSM</b>	Lennox Cloud conectivity GSM communication
<b>CPGR</b>	Coils protection : metallic grille	<b>CETH</b>	Lennox Cloud connectivity Ethernet communication
<b>LLWT</b>	Low leaving water temperature down to -12°C	<b>ECLO</b>	LonWorks® interface FTT10
<b>PHRF</b>	Hot sanitary water supply : desuperheater	<b>BNET</b>	BACnet® interface MSTP
<b>RLKD</b>	Refrigerant leak detection	<b>MBUS</b>	ModBus interface RS485
<b>SPLP</b>	Hydraulic module with low-pressure single pump	<b>MBIP</b>	ModBus and BACnet® interface TCP/IP
<b>DPLP</b>	Hydraulic module with low-pressure twin pump	<b>DM60</b>	Remote advanced display (supplied loose)
<b>SPEL</b>	"Hydraulic module with eDrive low-pressure single pump"	<b>DS60</b>	Service display (supplied loose)
<b>DPEL</b>	Hydraulic module with eDrive low-pressure twin pump	<b>DCBO</b>	Remote control: customer drive contact input/output
<b>SPHP</b>	Hydraulic module with high-pressure single pump	<b>ELME</b>	Electric energy meter
<b>DPHP</b>	Hydraulic module with high-pressure twin pump	<b>PHCT</b>	Phase reversal protection
<b>SPEH</b>	"Hydraulic module with eDrive high-pressure single pump"	<b>POWF</b>	Power factor correction
<b>DPEH</b>	"Hydraulic module with eDrive high-pressure twin pump"	<b>SOFT</b>	Soft starter
<b>BYVC</b>	Bypass Valve for delta P control with eDrive pump (supplied loose)	<b>EBFM1</b>	Electrical box upgrade ventilation : 1 fan
<b>WTNG</b>	Water tank	<b>EBFM2</b>	Electrical box upgrade ventilation : 2 fan
<b>WTHS</b>	Water tank electrical heater Standard	<b>ALWA</b>	Aluminum wires adaptor (supplied loose)
<b>WTHH</b>	Water tank electrical heater High	<b>AVUB</b>	Anti-vibration mounts rubber type (supplied loose)
<b>WFIF</b>	Water fi lter (supplied loose)	<b>SLCR</b>	Wooden crate for long distance
<b>KGRL</b>	Flange connection (supplied loose)		

## ACOUSTIC OPTION

### LOW NOISE LEVEL OPTION (CODE LNCJ)

For noise-sensitive environments and areas, the compressors are equipped with a high-performance acoustic cover allowing **the noise level to be reduced without any reduction in performance.**

## OPTIONS FOR FAN AND EXTERNAL COILS

### STANDARD VARIABLE AIR FLOW CONTROL BY EC FAN

The standard variable air flow control by EC fan offers the following advantages comparing to the option fix speed AC fan (SFAC):

- Year-round operation down to -20 °C outdoor temperature in cooling mode.
- Year-round operation up to 30 °C outdoor temperature in heating mode (heat pump).
- A further increase in energy savings through improved
- seasonal efficiencies (floating HP).
- Intelligent noise attenuation management, programmable night and day, combined with acoustic covers.
- Available static pressure up to 210/250 Pa for encased and indoor applications (fan curves on page 30).

Option code	Type	Available static pressure
<b>Standard</b>	EC fan	90 to 140 Pa
<b>SFAC</b>	AC fan	70 to 90 Pa
<b>HIFP</b>	High-pressure EC fan	210 to 250 Pa

### FLOATING HIGH PRESSURE IN COOL MODE

LENNOX optimizes the performance of its eCOMFORT units in cool mode by using EC fans , allowing maximum savings to be achieved. We determine an optimal correlation between the condensation temperature and the outside air temperature, which allows us to obtain the lowest possible consumption for the compressors/condenser fan motors.

### ANTI-CORROSION PROTECTION: LENGUARD (CODE ACTR)

For installations in potentially aggressive environments such as coastal or industrial areas, LENNOX offers the option of non-toxic, water-based anti-corrosion protection treatment for condensers, validated over 10,000 hours of salt spray testing (ASTM B117 standard)

### METAL COIL PROTECTION GRILLS (CODE CPGR)

Black metal grills are used to protect the coils from impact during transport of the unit and for protection against bad weather. They also protect the users from sustaining cuts.

## OPTIONS FOR REFRIGERATION CIRCUIT

### LOW WATER TEMPERATURE OPERATION DOWN TO -12°C (CODE LLWT)

This option is necessary to increase the cooling operating range between +5°C and -12°C outlet water for industrial processes or ice storage.

### DESUPERHEATER: HOT WATER FOR SANITARY PURPOSES (CODE PHRF)

On eCOMFORT units from 90 to 210 kW, a plate heat exchanger on each refrigeration circuit enables production of hot water up to 70°C. **Heat recovery is greater than 20%** of the rejected heat depending on the temperatures required. The plate heat exchangers are thermally insulated.

### REFRIGERANT LEAK DETECTION (CODE RLKD)

Refrigerant leak detection prevents performance and efficiency degradation as well as unwanted downtime and **extends maintenance intervals** in terms of leak checking.

Refrigerant leak detection allows the customer to check, via the temperature and pressure sensors in the refrigeration circuit, whether the amount of refrigerant varies during the life cycle of the unit.

Via the eClimatic controller, these sensors provide the customer with information about the status of the refrigeration circuit.

## HYDRAULIC OPTIONS:

### Hydraulic module:

The hydraulic module is integrated in the eCOMFORT unit. It is composed of one or two pumps and all the hydraulic equipment required for **fast commissioning** on-site:

- single pump or twin pumps,
- vane-type water flow controller,
- expansion tank,
- pressure gage,
- drain valve,
- water temperature sensor,
- safety valve,
- air bleed,
- pressure tap,
- water pressure sensor with eDrive option.



Numerous hydraulic modules are available depending on the type of pump and static pressure requirement:

Option code	Type of pump	Available static pressure up to
SPLP	One single pump	130 kPa
DPLP	Two single pumps	
SPEL	One single pump with a speed variator (eDrive)	50 to 130 kPa
DPEL	Two single pumps with a speed variator (eDrive)	
SPHP	One single pump	200 kPa
DPHP	Two single pumps	
SPEH	One single pump with a speed variator (eDrive)	130 to 200 kPa
DPEH	Two single pumps with a speed variator (eDrive)	

The twin pumps are two independent single pumps and are mounted in tandem in normal/emergency operation.

The hydraulic modules with speed variator (eDrive) adapt to requirements from 50 to 200 kPa. Numerous control modes are available, **enabling significant savings on installation and energy consumption** as well as rapid returns on investment.

Please refer to the corresponding chapter on variable water flow.

### BYPASS VALVE FOR $\Delta P$ CONTROL WITH VARIABLE SPEED PUMP (EDRIVE) (CODE BYVC)

The bypass valve controlled by the unit is essential on variable water flow systems regulated in constant  $\Delta P$  and with terminals equipped with 2-way valves.

This configuration ensures the best energy savings on the installation and the energy costs of operating the pump. Please refer to the corresponding chapter on variable water flow.

The bypass valve is supplied not mounted on the unit.

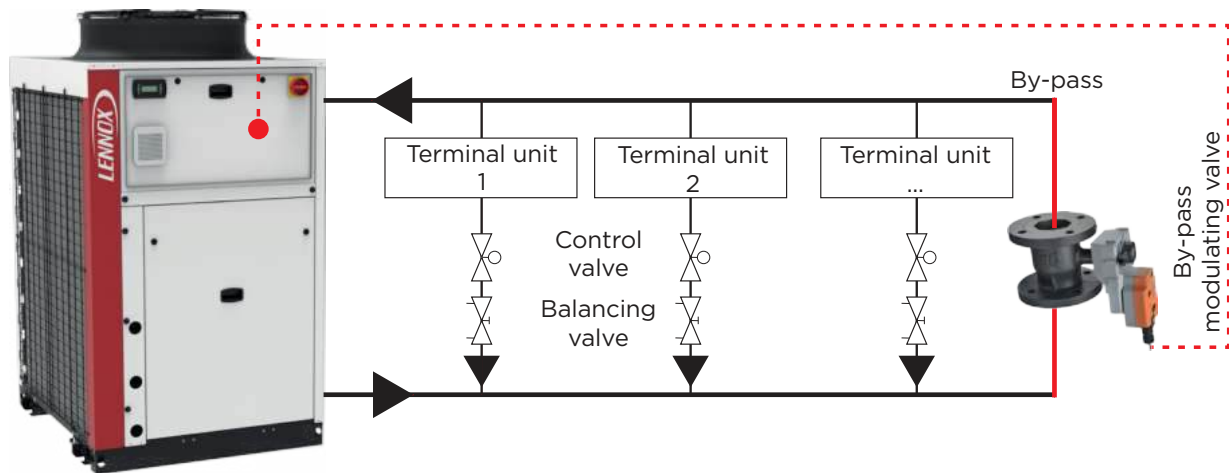

By-pass valve information	035S → 045S	055S → 080S	090S → 125D	160D → 210D
Connection diameter	DN 20	DN 25	DN 32	DN 40
Connection type	Threaded - Female			

## HYDRAULIC OPTIONS (CONT.) :

### BUFFER TANK (CODE WTNG)

The buffer tank is an essential option in the case of a water loop of low volume or with fast variable thermal load.

This tank is placed on the water return and **ensures sizable energy storage as well as a buffer effect** with:

- precision and stability in the outlet water temperature,
- inertia on water return, avoiding untimely operation and thus short cycles unacceptable for the compressors = reliability,
- elimination of the discomfort associated with the defrost cycles on the heat pumps.

The water chillers (GAC type) benefit from a large-volume buffer tank:

Size	Volume (liters)
<b>035S → 060S</b> <b>35 → 60 kW</b> *060S only Advanced version	100
<b>065S → 115S</b> <b>65 → 115 kW</b>	175
<b>125S → 140S</b> <b>125 → 140 kW</b> <b>110D → 140D</b> <b>110 → 140 kW</b>	250
<b>160D → 210D</b> <b>160 → 210 kW</b>	325

### MODULATING ELECTRIC HEATING ELEMENTS (ON HEAT PUMP ONLY):

In extreme cold, auxiliary modulating electric heating elements **ensure thermal comfort is maintained**. They are integrated in the unit, directly in the buffer tank.

High-power auxiliary modulating electric heating elements are also available **to guarantee and secure thermal comfort** should a thermodynamic circuit fail.

Power of electric heating elements:

Option code	Type	Size of unit			
		035S → 060S	065S → 115S	125S → 140S 110D → 140D	160D → 210D
<b>WTHS</b>	Standard electrical power	9kW	18kW	27kW	36kW
<b>WTHH</b>	Higher electrical power	24kW	24kW	36kW	48kW

### WATER FILTER (CODE WFIF)

A Y filter with stainless steel sieve (filtration diameter: 1 mm) is available:

- to screw on sizes **035S** to **060S** (from 35 to 60 kW),
- with PN16 flange on sizes **065S** to **210D** (from 65 to 210kW).

This protection must be mounted on the customer's supply piping in order to protect the evaporator from all possible impurities. The filter is supplied not mounted on the unit.

### FLANGE CONNECTION: (CODE KGRL)

Two connection sleeves with Victaulic groove on one side and flange on the opposite side are available. The connections are supplied not mounted on the unit.

### FROST PROTECTION (CODE APEP, APPP OR APPW)

On water chillers and heat pumps, if the water is not glycoled, frost protection down to -20 °C outdoor temperature is available:

- electric tracing of plate exchanger and pipes,
- electric heating elements included in the buffer tank.

Electric power of frost-protection heating elements in tank:

	Size of unit			
	035S → 060S	065S → 115S	125S → 140S 110D → 140D	160D → 210D
Electrical power	2.25 kW	6 kW	9 kW	12 kW

## CONTROL AND COMMUNICATION

### LONWORKS FTT10 COMMUNICATION INTERFACE (CODE ECLO)

This card is a LonWorks interface, required for any connection between a GTC system with Lon protocol. No other equipment is required to establish LonWorks® dialog. One card per machine is required. The list of variables can be found in the eClimatic controller manual.

### BACNET MSTP COMMUNICATION INTERFACE (CODE BNET)

This card is a communication interface that uses the BACnet® protocol and enables communication with a BACnet MSTP system. This card is essential for any connection between the unit and a LennoxHydrocontrol system. The list of variables can be found in the eClimatic manual

### MODBUS RS485 COMMUNICATION INTERFACE (CODE MBUS)

This card is a communication interface that uses the Modbus protocol and enables communication with a Modbus RS485 system. The list of variables can be found in the eClimatic manual.

### MODBUS OR BACNET TCP/IP COMMUNICATION INTERFACE (CODE EWFS)

This card is a communication interface that uses the Modbus/BACnet TCP/IP protocol and enables communication with an IP network. The list of variables can be found in the eClimatic manual.

### REMOTE DISPLAY (CODE DM60)

The optional “DM Multi” remote display has the same design and the same advanced functions as the “DC Advanced” display on the front. It offers the following additional functions:

- remote connection up to 500 m,
- wall mounting,
- ability to manage up to 8 units with a single display, the units must be connected to the master/slave bus.



### SERVICE DISPLAY (CODE DS60)

The “DS Service” service display, specifically for the experts, allows the technical service or maintenance personnel to adjust, read and modify all parameters of the unit.



### REMOTE CONTROL:

#### ADDITIONAL CLIENT INPUTS/OUTPUTS (CODE DCBO)

An expansion card is available with 10 universal inputs (NTC, 4/20mA, TOR dry contact) and 6 additional logic outputs. Each input/output can be parameterized to **allow remote control of the installation.**



## ELECTRIC OPTIONS

### ELECTRICAL ENERGY METER (CODE ELME)

Current transformers (TI) are placed on the customer's power supply cables. They convert the main current into a secondary current (0 to 5 A) sent to an energy meter.

The energy meter communicates the following values to the eClimatic system:

- active power at the time t in kW,
- power factor (cos phi),
- total active energy meter in kWh.

These values are displayed on the energy meter and forwarded to the display on the front as well as the remote and service displays.

They can be forwarded to a GTC via Modbus or BACnet (RS485 or TCP/IP) or LonWorks communication and made available on our LennoxCloud remote monitoring system.

### PHASE PROTECTION (CODE PHCT)

The phase controller is recommended when the power supply is unreliable or unstable, or when using an emergency generator. It **protects the components of the unit** against overvoltage, undervoltage or phase failure (phase reversal or loss).

### POWER FACTOR CORRECTION (CODE POWF)

On eCOMFORT units from 90 to 210 kW, power factor correction improves the electrical efficiency of the unit. The module compensates the phase angle (Cos Phi) between the voltage and the current by using capacitors and thus **helps reduce electrical energy consumption**.

### COMPRESSOR SOFT START (CODE SOFT)

With compressor soft start, the starter reduces the stresses on the installation:

- **Reduction of installation cost** by reducing the size of the upstream transformer,
- Reduction of loads in electrical distribution, current spikes down to -40% and drops in voltages related to engine start-ups,
- **Reduction of machine operating costs** by reducing the mechanical stresses,
- Automatic adaptation to network frequency,
- Protection against transient or permanent underload and overcurrent.

### ENHANCED VENTILATION OF THE ELECTRICAL CABINET: 1 FAN (CODE EBFM1)

A **system for cooling the electrical cabinet** is available as an option for specific climates and applications.

This option is obligatory on units from 35 to 80 kW:

- for operation above 48°C outside air,
- with the eDrive option: variable-speed pump(s).

This option is obligatory on units from 90 to 210 kW with the eDrive option (variable speed pump(s)).

### ENHANCED VENTILATION OF THE ELECTRICAL CABINET: 2 FANS (CODE EBFM1)

On units from 90 to 210 kW, a **double system for cooling** the electrical cabinet is available as an option for specific climates and applications.

This option is obligatory on units from 90 to 210 kW for operation above 48°C outside air.

### ADAPTER FOR POWER SUPPLY WITH ALUMINUM CABLES (CODE ALWA)

A special adapter kit is available for connecting the unit with aluminum cables.

This kit is supplied not mounted on the unit.

### ANTI-VIBRATION MOUNTS (CODE AVUB)

These rubber anti-vibration mounts reduce the transmission of vibrations to the ground and the noise level in general. They are fixed underneath the unit at the points specified in the installation manual. They are supplied not mounted.

### PROTECTION FOR LONG-DISTANCE TRANSPORT (CODE SLCR)

The entire unit can be packaged in a slatted crate for protection during very long distance transport by truck or container.



# GENERAL DATA

eCOMFORT - GAC		B BOX			B+ BOX			C BOX			
		035S	040S	045S	050S	055S	060S	065S	070S	080S	
<b>Cooling mode</b>											
Cooling capacity	kW	38,4	41,6	47,5	51,8	55	63,6	64,3	70	86,3	
Total absorbed power <sup>(1)</sup>		12,7	13,8	15,8	17	18,5	21,1	20,4	22,6	26,9	
EER <sup>(1)</sup>		3,02	3	3,02	3,05	2,97	3,02	3,14	3,09	3,21	
Eurovent energy class <sup>(1)</sup> - Full load operation											
		B	B	B	B	B	B	A	B	A	
Comfort Application	Seasonal Energy Efficiency Ratio <sup>(2)</sup> <b>SEER</b>	4,36	4,6	4,3	4,46	4,35	4,38	4,6	4,58	4,61	
	Seasonal energy efficiency <sup>(3)</sup> <b>η<sub>s,c</sub></b>	171	181	169	175	171	172	181	180	181	
Process Application	Seasonal Energy Performance Ratio <sup>(4)</sup> <b>SEPR</b> - High temperature (7°C)	6,15	6,63	5,61	5,68	5,59	5,53	5,79	5,72	5,90	
	Seasonal Energy Performance Ratio <sup>(5)</sup> <b>SEPR</b> - Medium temperature (-8°C)	3,68	3,88	3,83	3,80	3,81	3,81	3,81	3,83	3,96	
Comfort Application	with AC Fans	Seasonal Energy Efficiency Ratio <sup>(2)</sup> <b>SEER</b>	4,26	4,51	4,23	4,37	4,2	4,21	4,35	4,39	4,5
		Seasonal energy efficiency <sup>(3)</sup> <b>η<sub>s,c</sub></b>	167	177	166	172	165	165	171	173	177
Process Application	with AC Fans	Seasonal Energy Performance Ratio <sup>(4)</sup> <b>SEPR</b> - High temperature (7°C)	5,78	6,30	5,41	5,49	5,23	5,18	5,37	5,35	5,66
		Seasonal Energy Performance Ratio <sup>(5)</sup> <b>SEPR</b> - Medium temperature (-8°C)	3,53	3,84	3,74	3,81	3,55	3,56	3,68	3,63	3,87
<b>Refrigeration circuit</b>											
Number of circuits											
Refrigerant charge (circuit 1)	kg	3	3,5	3,7	4,5	4,6	4,7	6	6,2	7,4	
Refrigerant charge (circuit 2)	kg	-	-	-	-	-	-	-	-	-	
Refrigerant charge (total)	kg	3	3,5	3,7	4,5	4,6	4,7	6	6,2	7,4	
Type of expansion valve											
-											
<b>Compressors</b>											
Multi stage Scroll compressors											
Number of compressors											
		2	2	2	2	2	2	2	2	2	
Type											
		Tandem	Tandem	Tandem	Tandem	Tandem	Tandem	Tandem	Tandem	Tandem	
Capacity steps											
		0-50-100 %	0-50-100 %	0-50-100 %	0-46-54-100%	0-50-100 %	0-44-56-100%	0-44-56-100%	0-40-60-100%	0-50-100%	
Rotation Speed (RPM)											
		2900									
Oil type											
		4MA POE R32 Only									
Oil load	kg	2x1.77	2x1.77	2x2.51	2x2.51	2x2.51	2.51+3.25	2.51+3.25	2.51+3.25	2x3.25	
<b>Condenser</b>											
Microchannel, aluminium tubes and fins											
Number of condensers											
		1	1	1	1	1	1	1	1	1	
<b>Condenser fan</b>											
Axial fan											
Number of condenser fans											
		1	1	1	1	1	1	2	2	2	
Nominal airflow rate	m <sup>3</sup> /h	15897	15897	15897	16818	16818	24381	31794	31794	31794	
Rotation speed (rpm)		741	741	741	742	742	1008	741	741	741	
<b>Evaporator</b>											
Braze plate heat exchanger											
Number of evaporators											
		1	1	1	1	1	1	1	1	1	
Nominal water flow rate	m <sup>3</sup> /h	6,6	7,18	8,13	8,86	9,74	10,94	10,93	12,13	14,85	
Nominal pressure drop	kPa	38	33	41	36	42	43	33	40	40	
Water volume	L	3,9	4,5	4,5	5,3	5,3	5,9	7,4	7,4	7,4	
Hydraulic service pressure without hydraulic module	kPa	1000									
<b>Hydraulic module (option)</b>											
Type of pump - Low or high pressure pump											
		Stainless steel centrifugal single or twin pump mounted in parallel									
Expansion vessel volume	L	18						35			
Hydraulic service pressure with pump(s)	kPa						350				
Insulated water tank	L	100						175			
Hydraulic service pressure with pump(s) and water tank	kPa						350				
<b>Hydraulic connections</b>											
Type of standard connection											
		Threaded male					Victaulic or Welded				
Inlet / Outlet connection diameters		1"1/2	1"1/2	1"1/2	1"1/2	1"1/2	1"1/2	2"			
Inlet / Outlet external diameters	mm	48,3	48,3	48,3	48,3	48,3	48,3	60,3			
Type of optional connection		Non Available					Flange DN65				
<b>Electrical data</b>											
Power supply											
		400V / 3 / 50Hz + T									
Maximum power	kW	17,4	18,8	20,6	22,3	24,0	28,8	28,3	30,9	37,0	
Maximum running current	A	28,1	31,0	35,4	38,1	40,9	47,5	47,0	52,6	62,9	
Starting current	A	115,98	108,43	146,6	157,6	160,35	164,35	163,8	208,8	219,09	
Short circuit unit capacity	kA	10									
Power factor		0,84									
<b>Acoustic data</b>											
Global sound power level - Standard unit											
		75,3	75,3	74,4	74,9	75,3	78,6	77,9	78,5	80,2	
Global sound power level Low noise unit with acoustic jacket	dB(A)	72,6	72,6	71,8	72,2	72,6	76,5	75,2	75,8	77,4	
<b>Dimensions</b>											
Length		1125	1125	1125	1125	1125	1125	2250	2250	2250	
Width	mm	1320	1320	1320	1320	1320	1320	1320	1320	1320	
Height with standard fan(s) and HIFP*		1740	1740	1740	2109	2109	2109	1779	1779	1779	
Height with SFAC*		1562	1562	1562	1854	1854	1854	1562	1562	1562	
Operating weight	kg	325	339	350	379	385	405	565	559	605	

(1) EUROVENT certified data, in accordance with standard EN 14511 :  
Cooling mode : Evaporator water temperature = 12/7°C / Outdoor air temperature = 35°C  
Heating mode : Condenser water temperature = 40/45°C / Outdoor air temperature = 7°C  
(2) SEER in accordance with standard EN 14825  
(3) Following ecodesign regulation EU 2016/2281 on space cooling, normalized leaving water temperature at 7°C, in accordance with standard EN 14825.

(4) Following ecodesign regulation EU 2016/2281 on process cooling units, normalized leaving water temperature at 7°C, in accordance with standard EN 14825.  
(5) Following ecodesign regulation EU 2015/1095 on process cooling chillers, normalized leaving water temperature at -8°C, in accordance with standard EN 14825

# GENERAL DATA

eCOMFORT - GAC		C+ BOX			D BOX					
		095S	110S	115S	125S	140S	110D	125D	140D	
<b>Cooling mode</b>										
Cooling capacity	kW	95,8	108,3	119,3	128,8	156,3	111,4	127,5	142,3	
Total absorbed power <sup>(1)</sup>		29,9	34,8	37,9	41,1	51,1	36,9	41,9	46,6	
EER <sup>(1)</sup>		3,2	3,11	3,15	3,13	3,03	3,02	3,04	3,05	
Eurovent energy class <sup>(1)</sup> - Full load operation		A	A	A	A	B	B	B	B	
Comfort Application	Seasonal Energy Efficiency Ratio <sup>(2)</sup> <b>SEER</b>	4,67	4,73	4,6	4,73	4,53	4,66	4,6	4,65	
	Seasonal energy efficiency <sup>(3)</sup> <b>η<sub>s,c</sub></b>	184	186	181	186	178	183	181	183	
Process Application	Seasonal Energy Performance Ratio <sup>(4)</sup> <b>SEPR</b> - High temperature (7°C)	5,86	5,80	5,77	5,77	5,52	5,70	5,54	5,51	
	Seasonal Energy Performance Ratio <sup>(5)</sup> <b>SEPR</b> - Medium temperature (-8°C)	3,87	3,90	3,93	3,91	3,89	3,94	3,89	3,92	
Comfort Application	with AC Fans	Seasonal Energy Efficiency Ratio <sup>(2)</sup> <b>SEER</b>	4,56	4,43	4,39	4,45	4,35	4,6	4,46	4,48
		Seasonal energy efficiency <sup>(3)</sup> <b>η<sub>s,c</sub></b>	179	174	173	175	171	181	175	176
Process Application	with AC Fans	Seasonal Energy Performance Ratio <sup>(4)</sup> <b>SEPR</b> - High temperature (7°C)	5,68	5,35	5,35	5,47	5,36	5,54	5,22	5,22
		Seasonal Energy Performance Ratio <sup>(5)</sup> <b>SEPR</b> - Medium temperature (-8°C)	3,90	3,60	3,65	3,74	3,71	3,93	3,67	3,71
<b>Refrigeration circuit</b>										
Number of circuits		1	1	1	1	1	2	2	2	
Refrigerant charge (circuit 1)	kg	9	9,2	9,4	9,2	9,4	4,5	4,6	4,7	
Refrigerant charge (circuit 2)	kg	-	-	-	-	-	4,5	4,6	4,7	
Refrigerant charge (total)	kg	9	9,2	9,4	9,2	9,4	9	9,2	9,4	
Type of expansion valve		Electronic expansion valve								
<b>Compressors</b>										
Multi stage Scroll compressors										
Number of compressors		2	2	2	3	3	2+2	2+2	2+2	
Type		Tandem	Tandem	Tandem	Trio	Trio	Tandem / Tandem	Tandem / Tandem	Tandem / Tandem	
Capacity steps		0-44-56-100%	0-38-62-100%	0-44-56-100%	0-33-67-100%	0-33-67-100%	0-25-50-75-100%	0-22-28-44-50-56-72-78-100%	0-20-30-40-50-60-70-80-100%	
Rotation Speed (RPM)		2900								
Oil type		4MA POE R32 Only								
Oil load	kg	3.25+4.44	3.25+4.44	2x4.44	3x3.25	3x4.44	2x(2x2.51)	2x(2.51+3.25)	2x(2.51+3.25)	
<b>Condenser</b>										
Microchannel, aluminium tubes and fins										
Number of condensers		1	1	1	1	1	1	1	1	
<b>Condenser fan</b>										
Axial fan										
Number of condenser fans		2	2	2	2	2	2	2	2	
Nominal airflow rate	m <sup>3</sup> /h	33636	33636	48763	47791	48374	33636	48763	53867	
Rotation speed (rpm)		742	742	1008	987	995	742 / 742	1008 / 1008	1106 / 1106	
<b>Evaporator</b>										
Braze plate heat exchanger										
Number of evaporators		1	1	1	1	1	1	1	1	
Nominal water flow rate	m <sup>3</sup> /h	16,44	19,03	19,16	20,67	21,92	22,13	24,13	26,26	
Nominal pressure drop	kPa	49	20	40	46	26	35	20	48	
Water volume	L	7,9	9,7	9,7	11,7	11,7	12,0	12,0	15,8	
Hydraulic service pressure without hydraulic module	kPa	1000								
<b>Hydraulic module (option)</b>										
Type of pump - Low or high pressure pump		Stainless steel centrifugal single or twin pump mounted in parallel								
Expansion vessel volume	L	35			35		50			
Hydraulic service pressure with pump(s)	kPa	350					250			
Insulated water tank	L	175								
Hydraulic service pressure with pump(s) and water tank	kPa	350								
<b>Hydraulic connections</b>										
Type of standard connection		Victaulic or Welded								
Inlet / Outlet connection diameters		2"1/2								
Inlet / Outlet external diameters	mm	76,1								
Type of optional connection		Flange DN65								
<b>Electrical data</b>										
Power supply		400V / 3 / 50Hz + E								
Maximum power	kW	41,5	47,1	54,3	57,4	72,4	48,0	57,6	64,5	
Maximum running current	A	70,0	79,2	90,0	96,9	120,0	81,6	95,0	108,6	
Starting current	A	273,34	320,34	331,2	253,13	323,3	201,1	211,78	264,79	
Short circuit unit capacity	kA	10								
Power factor		0,8								
<b>Acoustic data</b>										
Global sound power level - Standard unit	dB(A)	84,1	84,1	86,3	82,6	88,3	78,3	81,6	84,1	
Global sound power level Low noise unit with acoustic jacket		81,1	81,1	83,7	80,4	86,3	75,6	79,5	82,8	
<b>Dimensions</b>										
Length	mm	2250	2250	2250	2250	2250	2250	2250	2250	
Width		1320	1320	1320	1740	1740	1740	1740	1740	
Height with standard fan(s) and HIFP*		2071	2071	2071	2071	2071	2071	2071	2071	
Height with SFAC*		1854	1854	1854	1854	1854	1854	1854	1854	
Operating weight	kg	679	701	730	846	932	893	932	911	

(1) EUROVENT certified data, in accordance with standard EN 14511 :  
Cooling mode : Evaporator water temperature = 12/7°C / Outdoor air temperature = 35°C  
Heating mode : Condenser water temperature = 40/45°C / Outdoor air temperature = 7°C  
(2) SEER in accordance with standard EN 14825.  
(3) Following ecodesign regulation EU 2016/2281 on space cooling, normalized leaving water temperature at 7°C, in accordance with standard EN 14825.

(4) Following ecodesign regulation EU 2016/2281 on process cooling units, normalized leaving water temperature at 7°C, in accordance with standard EN 14825.  
(5) Following ecodesign regulation EU 2015/1095 on process cooling chillers, normalized leaving water temperature at -8°C, in accordance with standard EN 14825.

# GENERAL DATA

eCOMFORT - GAC		E BOX			
		160D	185D	210D	
<b>Cooling mode</b>					
Cooling capacity	kW	167,8	187,2	210,5	
Total absorbed power <sup>(1)</sup>		53,6	60,7	69,9	
EER <sup>(1)</sup>		3,13	3,08	3,01	
Eurovent energy class <sup>(1)</sup> - Full load operation					
		A	B	B	
Comfort Application	Seasonal Energy Efficiency Ratio <sup>(2)</sup> <b>SEER</b>	4,72	4,71	4,64	
	Seasonal energy efficiency <sup>(3)</sup> <b>η<sub>s,c</sub></b>	186	185	183	
Process Application	Seasonal Energy Performance Ratio <sup>(4)</sup> <b>SEPR</b> - High temperature (7°C)	5,80	5,64	5,45	
	Seasonal Energy Performance Ratio <sup>(5)</sup> <b>SEPR</b> - Medium temperature (-8°C)	3,98	3,93	3,87	
Comfort Application	with AC Fans	Seasonal Energy Efficiency Ratio <sup>(2)</sup> <b>SEER</b>	4,64	4,6	4,36
		Seasonal energy efficiency <sup>(3)</sup> <b>η<sub>s,c</sub></b>	183	181	171
Process Application	with AC Fans	Seasonal Energy Performance Ratio <sup>(4)</sup> <b>SEPR</b> - High temperature (7°C)	5,55	5,44	5,09
		Seasonal Energy Performance Ratio <sup>(5)</sup> <b>SEPR</b> - Medium temperature (-8°C)	3,87	3,85	3,56
<b>Refrigeration circuit</b>					
Number of circuits					
		2	2	2	
Refrigerant charge (circuit 1)	kg	7,3	7,5	7,6	
Refrigerant charge (circuit 2)	kg	7,3	7,5	7,6	
Refrigerant charge (total)	kg	14,5	15	15,2	
Type of expansion valve					
Electronic expansion valve					
<b>Compressors</b>					
Multi stage Scroll compressors					
Number of compressors					
		2+2	2+2	2+2	
Type					
		Tandem / Tandem	Tandem / Tandem	Tandem / Tandem	
Capacity steps					
		0-25-50-75-100 %	0-22-28-44-50-56-72-78-100%	0-19-31-38-50-62-69-81-100%	
Rotation Speed (RPM)					
		2900			
Oil type					
		4MA POE R32 Only			
Oil load	kg	2x(2x3.25)	2x(3.25+4.44)	2x(3.25+4.44)	
<b>Condenser</b>					
Microchannel, aluminium tubes and fins					
Number of condensers					
		1	1	1	
<b>Condenser fan</b>					
Axial fan					
Number of condenser fans					
		4	4	4	
Nominal airflow rate	m <sup>3</sup> /h	62693	92327	92327	
Rotation speed (rpm)		741 / 741	1004 / 1004	1004 / 1004	
<b>Evaporator</b>					
Braze plate heat exchanger					
Number of evaporators					
		1	1	1	
Nominal water flow rate	m <sup>3</sup> /h	28,85	32,21	36,35	
Nominal pressure drop	kPa	28	31	39	
Water volume	L	16,3	17,9	17,9	
Hydraulic service pressure without hydraulic module	kPa	1000			
<b>Hydraulic module (option)</b>					
Type of pump - Low or high pressure pump					
Stainless steel centrifugal single or twin pump mounted in parallel					
Expansion vessel volume	L	50			
Hydraulic service pressure with pump(s)	kPa	350			
Insulated water tank	L	325			
Hydraulic service pressure with pump(s) and water tank	kPa	350			
<b>Hydraulic connections</b>					
Type of standard connection					
Victaulic or Welded					
Inlet / Outlet connection diameters					
		3"			
Inlet / Outlet external diameters					
	mm	88,9			
Type of optional connection					
		Flange DN80			
<b>Electrical data</b>					
Power supply					
		400V / 3 / 50Hz + E			
Maximum power	kW	73,9	88,3	99,5	
Maximum running current	A	125,6	147,5	165,8	
Starting current	A	281,77	350,83	406,99	
Short circuit unit capacity	kA	10			
Power factor		0,8			
<b>Acoustic data</b>					
Global sound power level - Standard unit					
		83,2	87,5	87,5	
Global sound power level					
		80,4	85	85	
Low noise unit with acoustic jacket					
<b>Dimensions</b>					
Length		2250	2250	2250	
Width		2650	2650	2650	
Height with standard fan(s) and HIFP*	mm	2071	2071	2071	
Height with SFAC*		1854	1854	1854	
Operating weight		kg	1216	1340	1340

- (1) EUROVENT certified data, in accordance with standard EN 14511 :  
Cooling mode : Evaporator water temperature = 12/7°C / Outdoor air temperature = 35°C  
Heating mode : Condenser water temperature = 40/45°C / Outdoor air temperature = 7°C
- (2) SEER in accordance with standard EN 14825
- (3) Following ecodesign regulation EU 2016/2281 on space cooling, normalized leaving water temperature at 7°C, in accordance with standard EN 14825.

- (4) Following ecodesign regulation EU 2016/2281 on process cooling units, normalized leaving water temperature at 7°C, in accordance with standard EN 14825.
- (5) Following ecodesign regulation EU 2015/1095 on process cooling chillers, normalized leaving water temperature at -8°C, in accordance with standard EN 14825

# GENERAL DATA

eCOMFORT ADVANCED - GBC		B BOX	B+ BOX	C BOX		C+BOX		D BOX	
		040S	060S	070S	080S	110S	120S	125D	140D
<b>Cooling mode</b>									
Cooling capacity	kW	34,5	51,3	61,5	77,4	94,6	117,0	124,8	146,7
Total absorbed power <sup>(1)</sup>		10,2	15,8	19,5	23,9	28,9	36,8	40,9	48,6
EER <sup>(1)</sup>		3,38	3,24	3,15	3,24	3,28	3,18	3,05	3,02
Maximum Cooling capacity :	kW	43,7	65,1	71,2	87,7	108,3	132,1	133,8	154,9
EER at maximum capacity <sup>(1)</sup>		2,89	2,86	2,92	3,05	2,98	2,98	2,91	2,88
Minimum Cooling capacity :	kW	18,9	28,6	19,1	19,7	29,9	30,0	20,8	21,1
EER at minimum capacity <sup>(1)</sup>		2,95	2,77	2,25	1,59	2,91	2,00	1,66	1,43
Comfort Application	Seasonal Energy Efficiency Ratio <sup>(2)</sup> <b>SEER</b>	4.85	5.13	4.65	4.75	4.95	4.93	4.98	4.95
	Seasonal energy efficiency <sup>(3)</sup> <b>η<sub>s,c</sub></b>	191	202	183	187	195	194	196	195
Process Application	Seasonal Energy Performance Ratio <sup>(4)</sup> <b>SEPR</b> - High temperature (7°C)	6.72	6.62	6.05	6.08	6.33	6.01	5.71	5.53
	Seasonal Energy Performance Ratio <sup>(5)</sup> <b>SEPR</b> - Medium temperature (-8°C)	3.57	3.67	3.41	3.44	3.58	3.48	3.68	3.74
<b>Refrigeration circuit</b>									
Number of circuits		1	1	1	1	1	2	2	2
Refrigerant charge (circuit 1)	kg	9	9,2	9,4	9,2	9,4	4,5	4,6	4,7
Refrigerant charge (circuit 2)	kg	-	-	-	-	-	4,5	4,6	4,7
Refrigerant charge (total)	kg	9	9,2	9,4	9,2	9,4	9	9,2	9,4
Type of expansion valve		Electronic expansion valve							
<b>Compressors</b>									
Multi stage Scroll compressors									
Number of compressors		1	1	2	2	2	2	2+2	2+2
Type		Scroll variable	Scroll variable	Scroll tandem (variable + fix)	Scroll tandem (variable + fix)	Scroll tandem (variable + fix)	Scroll tandem (variable + fix)	Scroll (variable + fix) + tandem (fix + fix)	Scroll (variable + fix) + tandem (fix + fix)
Capacity steps		Variable	Variable	Variable	Variable	Variable	Variable	Variable	Variable
Rotation Speed (RPM)		1200 - 7200							
Oil type		4MA POE R32 Only							
Oil load	kg	2,51	2,51	2x2.51+1	2.51+3.58 +1	2.51+3.58 +1	2.51+4.44 +1	(2x2.51+1)+ (2.51+3.58)	(2.51+3.58+1)+ (2.51+3.58)
<b>Condenser</b>									
Microchannel, aluminium tubes and fins									
Number of condensers		1	1	1	1	1	1	1	1
<b>Condenser fan</b>									
Number of condenser fans		1	1	2	2	2	2	2	2
Nominal airflow rate	m <sup>3</sup> /h	15897	24381	31794	46707	33636	48763	48763	53867
Rotation speed (rpm)		741	1008	741	1005	742	1008	1008 / 1008	1106 / 1106
<b>Evaporator</b>									
Braze plate heat exchanger									
Number of evaporators		1	1	1	1	1	1	1	1
Nominal water flow rate	m <sup>3</sup> /h	5,96	8,85	10,61	13,35	16,31	20,17	21,53	25,31
Nominal pressure drop	kPa	23	29	31	33	30	29	25	22
Water volume	L	7,9	9,7	9,7	11,7	11,7	12,0	12,0	15,8
Hydraulic service pressure without hydraulic module	kPa	1000							
<b>Hydraulic module (option)</b>									
Type of pump - Low or high pressure pump		Stainless steel centrifugal single or twin pump mounted in parallel							
Expansion vessel volume	L	18				35			35
Hydraulic service pressure with pump(s)	kPa	350							
Insulated water tank	L	100				175			250
Hydraulic service pressure with pump(s) and water tank	kPa	350							
<b>Hydraulic connections</b>									
Type of standard connection		Victaulic or Welded							
Inlet / Outlet connection diameters		1"1/2	1"1/2	2		2"1/2			
Inlet / Outlet external diameters	mm	48,3	48,3	60,3		76,1			
Type of optional connection		Non available		Flange DN65		Flange DN65			
<b>Electrical data</b>									
400V / 3 / 50Hz + E									
Power supply		400V / 3 / 50Hz + E							
Maximum power	kW	16.4	25.3	28.7	37.5	42.4	55.2	58	68.3
Maximum running current	A	26.1	41	47.1	61.4	70.5	90.5	95.1	113.4
Starting current	A	26.1	41	166.6	217.6	226.7	331.7	211.9	269.6
Short circuit unit capacity	kA	10							
Power factor		0,84							
<b>Acoustic data</b>									
Global sound power level - Standard unit	dB(A)	82,5	83,3	82,8	84,1	84	86,3	84,4	86,1
Global sound power level Low noise unit with acoustic jacket		79,5	80,6	80,6	81,6	81,1	83,7	81,9	84,3
<b>Dimensions</b>									
Length	mm	1125	1125	2250	2250	2250	2250	2250	2250
Width		1320	1320	1320	1320	1320	1320	1740	1740
Height with standard fan(s) and HIFP*		1740	2109	1779	1779	2071	2071	2071	2071
Operating weight		kg	332	367	547	640	682	721	894

(1) EUROVENT certified data, in accordance with standard EN 14511 :  
Cooling mode : Evaporator water temperature = 12/7°C / Outdoor air temperature = 35°C  
Heating mode : Condenser water temperature = 40/45°C / Outdoor air temperature = 7°C  
(2) SEER in accordance with standard EN 14825  
(3) Following ecodesign regulation EU 2016/2281 on space cooling, normalized leaving water temperature at 7°C, in accordance with standard EN 14825.

(4) Following ecodesign regulation EU 2016/2281 on process cooling units, normalized leaving water temperature at 7°C, in accordance with standard EN 14825.  
(5) Following ecodesign regulation EU 2015/1095 on process cooling chillers, normalized leaving water temperature at -8°C, in accordance with standard EN 14825

# GENERAL DATA

eCOMFORT ADVANCED - GBC		E BOX		
		160D	185D	210D
<b>Cooling mode</b>				
Cooling capacity	kW	159,5	170,0	196,6
Total absorbed power <sup>(1)</sup>		50,6	54,1	64,2
EER <sup>(1)</sup>		3,15	3,14	3,06
Maximum Cooling capacity :	kW	169,0	179,5	210,5
EER at maximum capacity <sup>(1)</sup>		3,05	3,05	2,95
Minimum Cooling capacity :	kW	20,9	20,5	30,7
EER at minimum capacity <sup>(1)</sup>		1,85	0,99	1,34
Comfort Application	Seasonal Energy Efficiency Ratio <sup>(2)</sup> <b>SEER</b>	5.05	5.03	5.08
	Seasonal energy efficiency <sup>(3)</sup> <b>η<sub>s,c</sub></b>	199	198	200
Process Application	Seasonal Energy Performance Ratio <sup>(4)</sup> <b>SEPR</b> - High temperature (7°C)	6.01	5.95	5.64
	Seasonal Energy Performance Ratio <sup>(5)</sup> <b>SEPR</b> - Medium temperature (-8°C)	3.77	3.75	3.7
<b>Refrigeration circuit</b>				
Number of circuits		2	2	2
Refrigerant charge (circuit 1)	kg	7,3	7,5	7,6
Refrigerant charge (circuit 2)	kg	7,3	7,5	7,6
Refrigerant charge (total)	kg	14,6	15	15,2
Type of expansion valve		Electronic expansion valve		
<b>Compressors</b>				
Multi stage Scroll compressors				
Number of compressors		2+2	2+2	2+2
Type		Scroll (variable + fix) + tandem (fix + fix)	Scroll (variable + fix) + tandem (fix + fix)	Scroll (variable + fix) + tandem (fix + fix)
Capacity steps		Variable	Variable	Variable
Rotation Speed (RPM)		1200 - 7200		
Oil type		4MA POE R32 Only		
Oil load	kg	(2.51+3.58+1)+(2x3.58)	(2.51+3.58+1)+(3.58+4.44)	(2.51+3.58+1)+(3.58+4.44)
<b>Condenser</b>				
Microchannel, aluminium tubes and fins				
Number of condensers		1	1	1
<b>Condenser fan</b>				
Axial fan				
Number of condenser fans		4	4	4
Nominal airflow rate	m <sup>3</sup> /h	62693	92327	92327
Rotation speed (rpm)		741 / 741	1004 / 1004	1004 / 1004
<b>Evaporator</b>				
Braze plate heat exchanger				
Number of evaporators		1	1	1
Nominal water flow rate	m <sup>3</sup> /h	27,52	29,32	33,91
Nominal pressure drop	kPa	26	26	34
Water volume	L			
Hydraulic service pressure without hydraulic module	kPa	1000		
<b>Hydraulic module (option)</b>				
Type of pump - Low or high pressure pump		Stainless steel centrifugal single or twin pump mounted in parallel		
Expansion vessel volume	L	50		
Hydraulic service pressure with pump(s)	kPa	350		
Insulated water tank	L	400		
Hydraulic service pressure with pump(s) and water tank	kPa	350		
<b>Hydraulic connections</b>				
Type of standard connection		Victaulic or Welded		
Inlet / Outlet connection diameters		3"		
Inlet / Outlet external diameters	mm	88,9		
Type of optional connection		Flange DN80		
<b>Electrical data</b>				
Power supply		400V / 3 / 50Hz + E		
Maximum power	kW	71.7	81.6	94.8
Maximum running current	A	120	135.1	157.1
Starting current	A	276.3	338.5	398.3
Short circuit unit capacity	kA		10	
Power factor			0,8	
<b>Acoustic data</b>				
Global sound power level - Standard unit	dB(A)	85,2	87,3	87,5
Global sound power level		82,3	84,8	85,0
Low noise unit with acoustic jacket				
<b>Dimensions</b>				
Length	mm	2250	2250	2250
Width		2650	2650	2650
Height with standard fan(s) and HIFP*		2071	2071	2071
Operating weight		kg	1201	1283

(1) EUROVENT certified data, in accordance with standard EN 14511 :  
Cooling mode : Evaporator water temperature = 12/7°C / Outdoor air temperature = 35°C  
Heating mode : Condenser water temperature = 40/45°C / Outdoor air temperature = 7°C  
(2) SEER in accordance with standard EN 14825.  
(3) Following ecodesign regulation EU 2016/2281 on space cooling, normalized leaving water temperature at 7°C, in accordance with standard EN 14825.

(4) Following ecodesign regulation EU 2016/2281 on process cooling units, normalized leaving water temperature at 7°C, in accordance with standard EN 14825.  
(5) Following ecodesign regulation EU 2015/1095 on process cooling chillers, normalized leaving water temperature at -8°C, in accordance with standard EN 14825

# GENERAL DATA

eCOMFORT - GAH		B BOX			B+ BOX			C BOX			
		035S	040S	045S	050S	055S	060S	065S	070S	080S	
<b>Cooling mode</b>											
Cooling capacity		kW	37,7	41,2	46,9	50,5	56,1	63,2	64,3	69,6	84,7
Total absorbed power <sup>(1)</sup>			13,2	14,2	16,5	17,7	19	22	20,8	23,1	27,7
EER <sup>(1)</sup>			2,87	2,9	2,85	2,86	2,96	2,87	3,09	3,02	3,06
Eurovent energy class <sup>(1)</sup> - Full load operation		C	C	C	C	C	C	C	C	C	C
Comfort Application	Seasonal Energy Efficiency Ratio <sup>(2)</sup> <b>SEER</b>	4.21	4.48	4.26	4.33	4.18	4.18	4.56	4.53	4.46	
	Seasonal energy efficiency <sup>(3)</sup> <b>η<sub>s,c</sub></b>	165	176	167	170	164	164	179	178	175	
Process Application	Seasonal Energy Performance Ratio <sup>(4)</sup> <b>SEPR</b> - High temperature (7°C)	6.03	6.58	5.58	5.59	5.5	5.43	5.78	5.69	5.82	
	Seasonal Energy Performance Ratio <sup>(5)</sup> <b>SEPR</b> - Medium temperature (-8°C)	3.71	3.94	3.89	3.85	3.87	3.86	3.92	3.88	3.99	
Comfort Application	with AC Fans	Seasonal Energy Efficiency Ratio <sup>(2)</sup> <b>SEER</b>	4,15	4,40	4,19	4,25	4,13	4,15	4,28	4,35	4,40
		Seasonal energy efficiency <sup>(3)</sup> <b>η<sub>s,c</sub></b>	163	173	165	167	162	163	168	171	173
Process Application	with AC Fans	Seasonal Energy Performance Ratio <sup>(4)</sup> <b>SEPR</b> - High temperature (7°C)	5,71	6,21	5,38	5,40	5,17	5,14	5,29	5,32	5,57
		Seasonal Energy Performance Ratio <sup>(5)</sup> <b>SEPR</b> - Medium temperature (-8°C)	3,52	3,83	3,75	3,77	3,53	3,55	3,64	3,64	3,84
<b>Heating mode</b>											
Net Heating Capacity		kW	39	42,1	48,4	52,2	56,6	64,2	64,9	70,4	84,9
Total absorbed power <sup>(1)</sup>			13,2	14,1	15,8	17,4	18,9	21,8	20,4	23	26,8
COP			2,95	2,99	3,06	2,99	2,99	2,95	3,18	3,06	3,17
Eurovent energy class <sup>(1)</sup> - Full load operation		C	C	B	C	C	C	B	B	B	B
Comfort Application	with AC Fans	Seasonal Coefficient of Performance <sup>(6)</sup> <b>SCOP</b>	3.46	3.54	3.57	3.56	3.54	3.54	3.65	3.63	3.63
		Seasonal energy efficiency <sup>(7)</sup> <b>η<sub>s,h</sub></b>	136	139	140	140	139	139	143	142	142
	with AC Fans	Seasonal Coefficient of Performance <sup>(6)</sup> <b>SCOP</b>	3,31	3,44	3,45	3,49	3,28	3,3	3,58	3,64	3,5
		Seasonal energy efficiency <sup>(7)</sup> <b>η<sub>s,h</sub></b>	129	134	135	137	128	129	140	143	137
Seasonal energy efficiency class <sup>(8)</sup>		A+	A+	A+	A+	A+	A+	A+	A+	A+	A+
<b>Refrigeration circuit</b>											
Number of circuits		1	1	1	1	1	1	1	1	1	1
Refrigerant charge (circuit 1)		kg	5,5	6,5	7	8,5	8,8	9	10	10,5	14
Refrigerant charge (circuit 2)		kg	-	-	-	-	-	-	-	-	-
Refrigerant charge (total)		kg	5,5	6,5	7	8,5	8,8	9	10	10,5	14
Type of expansion valve		Electronic expansion valve									
<b>Compressors</b>											
Multi stage Scroll compressors											
Number of compressors		2	2	2	2	2	2	2	2	2	2
Type		Tandem	Tandem	Tandem	Tandem	Tandem	Tandem	Tandem	Tandem	Tandem	Tandem
Capacity steps		0-50-100%	0-50-100%	0-50-100%	0-46-54-100%	0-50-100%	0-44-56-100%	0-44-56-100%	0-40-60-100%	0-50-100%	0-50-100%
Rotation Speed (RPM)		2900									
Oil type		4MA POE R32 only									
Oil load		kg	2x1.77	2x1.77	2x2.51	2x2.51	2x1.325	2.51+3.25	2.51+3.25	2x3.25	2x3.25
<b>Condenser</b>											
Microchannel, aluminium tubes and fins											
Number of condensers		1	1	1	1	1	1	1	1	1	1
<b>Condenser fan</b>											
Axial fan											
Number of condenser fans		1	1	1	1	1	1	2	2	2	2
Nominal airflow rate		m <sup>3</sup> /h	15697	15697	15697	16771	24218	24218	31395	31395	31395
Rotation speed (rpm)		741	741	741	742	1007	1007	741	741	741	741
<b>Evaporator</b>											
Brazed plate heat exchanger											
Number of evaporators		1	1	1	1	1	1	1	1	1	1
Nominal water flow rate		m <sup>3</sup> /h	6,51	7,11	8,09	8,71	9,67	10,9	11,09	12,01	14,61
Nominal pressure drop		kPa	37	32	30	34	34	33	34	39	39
Water volume		L	3,9	4,5	5,3	5,3	5,9	6,9	7,4	7,4	7,4
Hydraulic service pressure without hydraulic module		kPa	1000								
<b>Hydraulic module (option)</b>											
Type of pump - Low or high pressure pump		Stainless steel centrifugal single or twin pump mounted in parallel									
Expansion vessel volume		L	18						35		
Hydraulic service pressure with pump(s)		kPa	350			350					
Insulated water tank		L	100				-		175		
Hydraulic service pressure with pump(s) and water tank		kPa	350						350		
<b>Hydraulic connections</b>											
Type of standard connection		Threaded male						Victaulic or Welded			
Inlet / Outlet connection diameters		1"1/2	1"1/2	1"1/2	1"1/2	1"1/2	1"1/2	2"			
Inlet / Outlet external diameters		mm	48,3	48,3	48,3	48,3	48,3	60,3			
Type of optional connection		Non Available						Bride DN65			
<b>Electrical data</b>											
Power supply		400V / 3 / 50Hz + E									
Maximum power		kW	17,38	18,82	20,64	22,33	25,38	28,83	28,33	30,93	36,98
Maximum running current		A	28,11	31,01	35,35	38,1	42,85	47,53	46,98	52,59	62,88
Starting current		A	115,98	108,43	146,6	157,6	162,35	164,35	163,8	208,8	219,09
Short circuit unit capacity		kA	10								
Power factor		0,84									
<b>Acoustic data</b>											
Global sound power level - Standard unit		dB(A)	75,3	75,3	74,4	74,9	75,3	78,6	77,9	78,5	80,2
Global sound power level			72,6	72,6	71,8	72,2	72,6	76,5	75,2	75,8	77,4
Low noise unit with acoustic jacket											
<b>Dimensions</b>											
Length		mm	1125	1125	1125	1125	1125	1125	2250	2250	2250
Width			1320	1320	1320	1320	1320	1320	1320	1320	1320
Height with standard fan(s) and HIFP*			1740	1740	1740	2109	2109	2109	1779	1779	1779
Height with SFAC*			1562	1562	1562	1854	1854	1854	1562	1562	1562
Operating weight		kg	350	369	385	416	424	448	614	608	649

- (1) EUROVENT certified data, in accordance with standard EN 14511 :  
Cooling mode : Evaporator water temperature = 12/7°C / Outdoor air temperature = 35°C  
Heating mode : Condenser water temperature = 40/45°C / Outdoor air temperature = 7°C
- (2) SEER in accordance with standard EN 14825.
- (3) Following ecodesign regulation EU 2016/2281 on space cooling, normalized leaving water temperature at 7°C, in accordance with standard EN 14825.
- (4) Following ecodesign regulation EU 2016/2281 on process cooling units, normalized leaving water temperature at 7°C, in accordance with standard EN 14825.

- (5) Following ecodesign regulation EU 2015/1095 on process cooling chillers, normalized leaving water temperature at -8°C, in accordance with standard EN 14825
- (6) SCOP in accordance with standard EN 14825. Heating mode performance is defined for average climate conditions.
- (7) Following ecodesign regulation EU 813/2013 on space heaters, normalized leaving water temperature at 35°C, in accordance with standard EN 14825, average climate conditions.
- (8) Following energy labelling regulation EU 811/2013 on space heaters.

# GENERAL DATA

eCOMFORT - GAH		C+ BOX			D BOX					
		095S	110S	115S	125S	140S	110D	125D	140D	
<b>Cooling mode</b>										
Cooling capacity	kW	94,1	105,3	118	126,4	152	108,6	125,3	140,3	
Total absorbed power <sup>(1)</sup>		30,9	36,4	39,4	42,7	54,8	38,4	43,3	48,4	
EER <sup>(1)</sup>		3,05	2,9	2,99	2,96	2,78	2,83	2,89	2,9	
Eurovent energy class <sup>(1)</sup> - Full load operation										
		C	C	C	C	C	C	C	C	
Comfort Application	Seasonal Energy Efficiency Ratio <sup>(2)</sup> <b>SEER</b>	4.56	4.6	4.39	4.62	4.36	4.56	4.42	4.49	
	Seasonal energy efficiency <sup>(3)</sup> <b>η<sub>s,c</sub></b>	180	181	173	182	171	179	174	177	
Process Application	Seasonal Energy Performance Ratio <sup>(4)</sup> <b>SEPR</b> - High temperature (7°C)	5.81	5.73	5.59	5.65	5.31	5.64	5.4	5.36	
	Seasonal Energy Performance Ratio <sup>(5)</sup> <b>SEPR</b> - Medium temperature (-8°C)	3.93	3.94	3.94	3.9	3.85	3.92	3.84	3.85	
Comfort Application	Seasonal Energy Efficiency Ratio <sup>(2)</sup> <b>SEER</b>	4,46	4,34	4,27	4,37	4,25	4,48	4,35	4,38	
	Seasonal energy efficiency <sup>(3)</sup> <b>η<sub>s,c</sub></b>	175	171	168	172	167	176	171	172	
Process Application	Seasonal Energy Performance Ratio <sup>(4)</sup> <b>SEPR</b> - High temperature (7°C)	5,58	5,25	5,24	5,39	5,25	5,47	5,11	5,10	
	Seasonal Energy Performance Ratio <sup>(5)</sup> <b>SEPR</b> - Medium temperature (-8°C)	3,87	3,57	3,60	3,69	3,65	3,88	3,61	3,64	
<b>Heating mode</b>										
Net Heating Capacity	kW	94,8	106,7	117,5	126,1	154,5	114	129,3	142,5	
Total absorbed power <sup>(1)</sup>		30,1	33,9	38,9	40,7	52,9	35,4	41,4	45,9	
COP		3,15	3,15	3,02	3,1	2,92	3,22	3,12	3,11	
Eurovent energy class <sup>(1)</sup> - Full load operation										
		B	B	B	B	C	A	B	B	
Comfort Application	Seasonal Coefficient of Performance <sup>(6)</sup> <b>SCOP</b>	3.59	3.61	3.58	3.73	3.7	3.78	3.76	3.79	
	Seasonal energy efficiency <sup>(7)</sup> <b>η<sub>s,h</sub></b>	141	141	140	146	145	148	147	148	
	with AC Fans	Seasonal Coefficient of Performance <sup>(6)</sup> <b>SCOP</b>	3,61	3,51	3,31	3,71	3,54	3,71	3,48	3,51
		Seasonal energy efficiency <sup>(7)</sup> <b>η<sub>s,h</sub></b>	141	137	129	146	139	145	136	138
			A+	A+	A+	A+	A+	A+	A+	A+
<b>Refrigeration circuit</b>										
Number of circuits		1	1	1	1	1	2	2	2	
Refrigerant charge (circuit 1)	kg	17	17,5	17,5	18	18,3	8,9	9,5	10	
Refrigerant charge (circuit 2)	kg	?	?	?	?	8,9	9,5	10	-	
Refrigerant charge (total)	kg	17	17,5	17,5	18	18,3	17,8	19	20	
Type of expansion valve		Electronic expansion valve								
<b>Compressors</b>										
Multi stage Scroll compressors										
Number of compressors		2	2	2	3	3	2+2	2+2	2+2	
Type		Tandem	Tandem	Tandem	Trio	Trio	Tandem / Tandem	Tandem / Tandem	Tandem / Tandem	
Capacity steps		0-44-56-100%	0-38-62-100%	0-44-56-100%	0-33-67-100%	0-33-67-100%	0-25-50-75-100%	0-22-28-44-50-56-72-78-100%	0-20-30-40-50-60-70-80-100%	
Rotation Speed (RPM)		2900								
Oil type		4MA POE R32 only								
Oil load	kg	3,25+4,44	3,25+4,44	2x4,44	3x3,25	3x4,44	2x(2x2,51)	2x(2,51+3,25)	2x(2,51+3,25)	
<b>Condenser</b>										
Microchannel, aluminium tubes and fins										
Number of condensers		1	1	1	1	1	1	1	1	
<b>Condenser fan</b>										
Axial fan										
Number of condenser fans		2	2	2	2	2	2	2	2	
Nominal airflow rate	m <sup>3</sup> /h	33541	33541	48437	48437	53425	33541	48437	53425	
Rotation speed (rpm)		742	742	1007	1007	1106	742 / 742	1007 / 1007	1106 / 1106	
<b>Evaporator</b>										
Braze plate heat exchanger										
Number of evaporators		1	1	1	1	1	1	1	1	
Nominal water flow rate	m <sup>3</sup> /h	16,23	18,17	20,35	21,8	26,22	18,74	21,61	24,2	
Nominal pressure drop	kPa	48	36	45	34	48	20	25	21	
Water volume	L	7,9	9,7	9,7	11,7	11,7	12,0	12,0	15,8	
Hydraulic service pressure without hydraulic module	kPa	1000								
<b>Hydraulic module (option)</b>										
Stainless steel centrifugal single or twin pump mounted in parallel										
Type of pump - Low or high pressure pump										
Expansion vessel volume	L	35			35			50		
Hydraulic service pressure with pump(s)	kPa				350					
Insulated water tank	L	175						250		
Hydraulic service pressure with pump(s) and water tank	kPa				350					
<b>Hydraulic connections</b>										
Victaulic or Welded										
Inlet / Outlet connection diameters		2"/2								
Inlet / Outlet external diameters	mm	76,1								
Type of optional connection		Flange DN65								
<b>Electrical data</b>										
400V / 3 / 50Hz + E										
Power supply										
Maximum power	kW	41,53	47,13	54,3	57,35	72,37	48	57,62	64,47	
Maximum running current	A	69,99	79,15	90,01	96,92	119,95	81,6	94,96	108,58	
Starting current	A	273,34	320,34	331,2	253,13	323,3	201,1	211,78	264,79	
Short circuit unit capacity	kA	10								
Power factor		0,84								
<b>Acoustic data</b>										
Global sound power level - Standard unit	dB(A)	84,1	84,1	86,3	82,6	88,3	78,3	81,6	84,1	
Global sound power level		81,1	81,1	83,7	80,4	86,3	75,6	79,5	82,8	
Low noise unit with acoustic jacket										
<b>Dimensions</b>										
Length	mm	2250	2250	2250	2250	2250	2250	2250	2250	
Width		1320	1320	1320	1740	1740	1740	1740	1740	
Height with standard fan(s) and HIFP*		2071	2071	2071	2071	2071	2071	2071	2071	
Height with SFAC*		1854	1854	1854	1854	1854	1854	1854	1854	
Operating weight		kg	742	771	793	918	1006	975	1017	998

- (1) EUROVENT certified data, in accordance with standard EN 14511:  
Cooling mode : Evaporator water temperature = 12/7°C / Outdoor air temperature = 35°C  
Heating mode : Condenser water temperature = 40/45°C / Outdoor air temperature = 7°C
- (2) SEER in accordance with standard EN 14825.
- (3) Following ecodesign regulation EU 2016/2281 on space cooling, normalized leaving water temperature at 7°C, in accordance with standard EN 14825.
- (4) Following ecodesign regulation EU 2016/2281 on process cooling units, normalized leaving water temperature at 7°C, in accordance with standard EN 14825.

- (5) Following ecodesign regulation EU 2015/1095 on process cooling chillers, normalized leaving water temperature at -8°C, in accordance with standard EN 14825
- (6) SCOP in accordance with standard EN 14825. Heating mode performance is defined for average climate conditions.
- (7) Following ecodesign regulation EU 813/2013 on space heaters, normalized leaving water temperature at 35°C, in accordance with standard EN 14825, average climate conditions.
- (8) Following energy labelling regulation EU 811/2013 on space heaters.

# GENERAL DATA

eCOMFORT - GAH		E BOX			
		160D	185D	210D	
<b>Cooling mode</b>					
Cooling capacity		kW	166,1	187,3	209,1
Total absorbed power <sup>(1)</sup>			55,1	62,5	73
EER <sup>(1)</sup>			3,01	3	2,86
Eurovent energy class <sup>(1)</sup> - Full load operation			C	C	C
Comfort Application	Seasonal Energy Efficiency Ratio <sup>(2)</sup> <b>SEER</b>		4.62	4.56	4.49
	Seasonal energy efficiency <sup>(3)</sup> <b>η<sub>s,c</sub></b>		182	179	176
Process Application	Seasonal Energy Performance Ratio <sup>(4)</sup> <b>SEPR</b> - High temperature (7°C)		5.73	5.49	5.27
	Seasonal Energy Performance Ratio <sup>(5)</sup> <b>SEPR</b> - Medium temperature (-8°C)		3.99	3.92	3.82
Comfort Application	with AC Fans	Seasonal Energy Efficiency Ratio <sup>(2)</sup> <b>SEER</b>	4,55	4,50	4,26
		Seasonal energy efficiency <sup>(3)</sup> <b>η<sub>s,c</sub></b>	179	177	167
Process Application	with AC Fans	Seasonal Energy Performance Ratio <sup>(4)</sup> <b>SEPR</b> - High temperature (7°C)	5,48	5,34	4,95
		Seasonal Energy Performance Ratio <sup>(5)</sup> <b>SEPR</b> - Medium temperature (-8°C)	3,85	3,81	3,50
<b>Heating mode</b>					
Net Heating Capacity		kW	170,7	190,3	216
Total absorbed power <sup>(1)</sup>			53,3	61	72,9
COP			3,2	3,12	2,96
Eurovent energy class <sup>(1)</sup> - Full load operation			A	B	C
Comfort Application	Seasonal Coefficient of Performance <sup>(6)</sup> <b>SCOP</b>		3.78	3.74	3.71
	Seasonal energy efficiency <sup>(7)</sup> <b>η<sub>s,h</sub></b>		148	147	145
with AC Fans	with AC Fans	Seasonal Coefficient of Performance <sup>(6)</sup> <b>SCOP</b>	3,64	3,64	3,38
		Seasonal energy efficiency <sup>(7)</sup> <b>η<sub>s,h</sub></b>	143	143	132
Seasonal energy efficiency class <sup>(8)</sup>			A+	A+	A+
<b>Refrigeration circuit</b>					
Number of circuits			2	2	2
Refrigerant charge (circuit 1)		kg	13,5	13,8	14
Refrigerant charge (circuit 2)		kg	13,5	13,8	14
Refrigerant charge (total)		kg	27	27,5	28
Type of expansion valve			Electronic expansion valve		
<b>Compressors</b>			Multi stage Scroll compressors		
Number of compressors			2+2	2+2	2+2
Type			Tandem / Tandem	Tandem / Tandem	Tandem / Tandem
Capacity steps			0-25-50-75-100	0-22-28-44-50-56-72-78-100	0-19-31-38-50-62-69-81-100%
Rotation Speed (RPM)			2900		
Oil type			4MA POE R32 only		
Oil load		kg	2x(2x3.25)	2x(3.25+4.44)	2x(3.25+4.44)
<b>Condenser</b>			Microchannel, aluminium tubes and fins		
Number of condensers			1	1	1
<b>Condenser fan</b>			Axial fan		
Number of condenser fans			4	4	4
Nominal airflow rate		m <sup>3</sup> /h	61740	90118	90118
Rotation speed (rpm)			741 / 741	1003 / 1003	1003 / 1003
<b>Evaporator</b>			Brazed plate heat exchanger		
Number of evaporators			1	1	1
Nominal water flow rate		m <sup>3</sup> /h	28,64	32,3	36,07
Nominal pressure drop		kPa	28	31	38
Water volume		L	16,3	17,9	17,9
Hydraulic service pressure without hydraulic module		kPa	1000		
<b>Hydraulic module (option)</b>			Stainless steel centrifugal single or twin pump mounted in parallel		
Type of pump - Low or high pressure pump			Stainless steel centrifugal single or twin pump mounted in parallel		
Expansion vessel volume		L	50		
Hydraulic service pressure with pump(s)		kPa	350		
Insulated water tank		L	325		
Hydraulic service pressure with pump(s) and water tank		kPa	350		
<b>Hydraulic connections</b>			Victaulic or Welded		
Type of standard connection			3"		
Inlet / Outlet connection diameters			88,9		
Inlet / Outlet external diameters		mm	88,9		
Type of optional connection			Flange DN80		
<b>Electrical data</b>			400V / 3 / 50Hz + E		
Power supply			400V / 3 / 50Hz + E		
Maximum power		kW	73,88	88,3	99,5
Maximum running current		A	125,56	147,48	165,8
Starting current		A	281,77	350,83	406,99
Short circuit unit capacity		kA	10		
Power factor			0,84		
<b>Acoustic data</b>					
Global sound power level - Standard unit		dB(A)	83,2	87,5	87,5
Global sound power level			80,4	85	85
Low noise unit with acoustic jacket					
<b>Dimensions</b>					
Length		mm	2250	2250	2250
Width			2650	2650	2650
Height with standard fan(s) and HIFP*			2071	2071	2071
Height with SFAC*			1854	1854	1854
			kg	1388	1463

- (1) EUROVENT certified data, in accordance with standard EN 14511 :  
Cooling mode : Evaporator water temperature = 12/7°C / Outdoor air temperature = 35°C  
Heating mode : Condenser water temperature = 40/45°C / Outdoor air temperature = 7°C
- (2) SEER in accordance with standard EN 14825.
- (3) Following ecodesign regulation EU 2016/2281 on space cooling, normalized leaving water temperature at 7°C, in accordance with standard EN 14825.
- (4) Following ecodesign regulation EU 2016/2281 on process cooling units, normalized leaving water temperature at 7°C, in accordance with standard EN 14825.

- (5) Following ecodesign regulation EU 2015/1095 on process cooling chillers, normalized leaving water temperature at -8°C, in accordance with standard EN 14825
- (6) SCOP in accordance with standard EN 14825. Heating mode performance is defined for average climate conditions.
- (7) Following ecodesign regulation EU 813/2013 on space heaters, normalized leaving water temperature at 35°C, in accordance with standard EN 14825, average climate conditions.
- (8) Following energy labelling regulation EU 811/2013 on space heaters.

# GENERAL DATA

		B BOX	B+ BOX	C BOX		C+ BOX		D BOX	
eCOMFORT ADVANCED - GBH		040S	060S	070S	080S	110S	120S	125D	140D
<b>Cooling mode</b>									
Cooling capacity	kW	33,6	50,0	60,6	71,9	87,6	109,2	123,5	144,1
Total absorbed power <sup>(1)</sup>		10,4	16,0	19,7	24,0	29,1	37,6	42,3	50,4
EER <sup>(1)</sup>		3,22	3,12	3,07	3,00	3,01	2,90	2,92	2,86
Maximum Colling Capacity	kg	42,0	62,6	69,7	81,0	99,1	121,5	131,2	151,5
EER at maximum capacity <sup>(1)</sup>		2,70	2,66	2,81	2,81	2,69	2,69	2,75	2,70
Minimum Cooling capacity	kg	18,7	27,9	18,0	17,5	27,0	26,8	21,3	21,4
EER at minimum capacity <sup>(1)</sup>		2,93	2,64	2,39	1,45	2,99	1,84	1,78	1,51
Comfort Application	Seasonal Energy Efficiency Ratio <sup>(2)</sup> <b>SEER</b>	4.73	4.73	4.6	4.6	4.68	4.68	4.85	4.8
	Seasonal energy efficiency <sup>(3)</sup> <b>η<sub>s,c</sub></b>	186	186	181	181	184	184	191	189
Process Application	Seasonal Energy Performance Ratio <sup>(4)</sup> <b>SEPR - High temperature (7°C)</b>	6.52	6.29	5.7	5.57	5.75	5.51	5.59	5.34
	Seasonal Energy Performance Ratio <sup>(5)</sup> <b>SEPR - Medium temperature (-8°C)</b>	3.66	3.7	3.32	3.08	3.24	3.14	3.66	3.67
<b>Heating mode</b>									
Net Heating Capacity	kW	34,4	51,1	64,0	78,4	94,0	116,5	126,8	146,9
Total absorbed power <sup>(1)</sup>		10,3	15,3	19,8	24,3	28,6	37,8	40,4	48,2
COP		3,36	3,33	3,23	3,23	3,29	3,08	3,14	3,05
Maximum Heating capacity	kg	45,6	66,9	75,2	89,5	108,2	130,6	137,8	156,4
EER at maximum capacity <sup>(1)</sup>		3,02	2,93	3,02	3,03	3,12	2,97	3,04	3,00
Minimum Heating capacity	kg	19,3	29,0	19,9	20,0	31,2	31,2	20,9	21,4
EER at minimum capacity <sup>(1)</sup>		4,06	3,82	4,42	3,81	4,81	3,55	1,89	2,02
Comfort Application	Seasonal Coefficient of Performance <sup>(6)</sup> <b>SCOP</b>	3.93	3.93	4	3.95	4.05	4.05	3.88	3.88
	Seasonal energy efficiency <sup>(7)</sup> <b>η<sub>s,h</sub></b>	154	154	157	155	159	159	152	152
<b>Refrigeration circuit</b>									
Number of circuits		1	1	1	1	1	1	2	2
Refrigerant charge (circuit 1)	kg	6,5	8,2	10,5	14	18,5	21	10	11
Refrigerant charge (circuit 2)	kg	-	-	-	-	-	-	10	11
Refrigerant charge (total)	kg	6,5	8,2	10,5	14	18,5	21	20	22
Type of expansion valve		Electronic expansion valve							
<b>Compressors</b>									
Number of compressors		1	1	2	2	2	2	2+2	2+2
Type of expansion valve		Scroll variable	Scroll variable	Scroll tandem (variable + fix)	Scroll tandem (variable + fix)	Scroll tandem (variable + fix)	Scroll tandem (variable + fix)	Scroll (variable + fix) + tandem (fix + fix)	Scroll (variable + fix) + tandem (fix + fix)
Capacity steps		Variable	Variable	Variable	Variable	Variable	Variable	Variable	Variable
Rotation Speed (RPM)		1200 - 7200							
Oil type		4MA POE R32 only							
Oil load	kg	2,51	2,51	2x2,51+1	2,51+3,58+1	2,51+3,58+1	2,51+4,44+1	(2x2,51+1)+(2,51+3,58)	(2,51+3,58+1)+(2,51+3,58)
<b>Condenser</b>									
Aluminium tubes and fins									
Number of condensers		1	1	1	1	1	1	1	1
<b>Condenser fan</b>									
Axial fan									
Number of condenser fans		1	1	2	2	2	2	2	2
Nominal airflow rate	m <sup>3</sup> /h	15697	24218	31395	45786	33541	48437	48437	53425
Rotation speed (rpm)		741	1007	741	1004	742	1007	1007 / 1007	1106 / 1106
<b>Evaporator</b>									
Braze plate heat exchanger									
Number of evaporators		1	1	1	1	1	1	1	1
Nominal water flow rate	m <sup>3</sup> /h	5,8	8,63	10,46	12,41	15,11	18,84	21,31	24,85
Nominal pressure drop	kPa	22	21	30	29	26	26	25	22
Water volume	L								
Hydraulic service pressure without hydraulic module	kPa	1000							
<b>Hydraulic module (option)</b>									
Type of pump - Low or high pressure pump		Stainless steel centrifugal single or twin pump mounted in parallel							
Expansion vessel volume	L	18				35			
Hydraulic service pressure with pump(s)	kPa					350			
Insulated water tank	L	100				170		250	
Hydraulic service pressure with pump(s) and water tank	kPa					350			
<b>Hydraulic connections</b>									
Type of standard connection		Threaded male			Victaulic or Welded				
Inlet / Outlet connection diameters		1 1/2	1 1/2	2"		2 1/2"			
Inlet / Outlet external diameters	mm	48,3	48,3	60,3		76,1			
Type of optional connection		Non available			Flange DN65				
<b>Electrical data</b>									
Power supply		400V / 3 / 50Hz + E							
Maximum power	kW	16.4	25.3	28.7	37.5	42.4	55.2	58	68.3
Maximum running current	A	26.1	41	47.1	61.4	70.5	90.5	95.1	113.4
Starting current	A	26.1	41	166.6	217.6	226.7	331.7	211.9	269.6
Short circuit unit capacity	kA	10							
Power factor		0,84							
<b>Acoustic data</b>									
Global sound power level - Standard unit	dB(A)	82,5	83,3	82,8	84,1	84	86,3	84,4	86,1
Global sound power level		79,5	80,6	80,6	81,6	81,1	83,7	81,9	84,3
Low noise unit with acoustic jacket									
<b>Dimensions</b>									
Length	mm	1125	1125	2250	2250	2250	2250	2250	2250
Width		1320	1320	1320	1320	1320	1320	1740	1740
Height with standard fan(s) and HIFP*		1740	2109	1779	1779	2071	2071	2071	2071
Operating weight		kg	351	401	609	705	746	789	1001

(1) EUROVENT certified data, in accordance with standard EN 14511 :  
Cooling mode : Evaporator water temperature = 12/7°C / Outdoor air temperature = 35°C  
Heating mode : Condenser water temperature = 40/45°C / Outdoor air temperature = 7°C  
(2) SEER in accordance with standard EN 14825.  
(3) Following ecodesign regulation EU 2016/2281 on space cooling, normalized leaving water temperature at 7°C, in accordance with standard EN 14825.  
(4) Following ecodesign regulation EU 2016/2281 on process cooling units, normalized leaving water temperature at 7°C, in accordance with standard EN 14825.

(5) Following ecodesign regulation EU 2015/1095 on process cooling chillers, normalized leaving water temperature at -8°C, in accordance with standard EN 14825  
(6) SCOP in accordance with standard EN 14825. Heating mode performance is defined for average climate conditions.  
(7) Following ecodesign regulation EU 813/2013 on space heaters, normalized leaving water temperature at 35°C, in accordance with standard EN 14825, average climate conditions.  
(8) Following energy labelling regulation EU 811/2013 on space heaters.

# GENERAL DATA

eCOMFORT ADVANCED - GBH		E BOX		
		160D	185D	210D
<b>Cooling mode</b>				
Cooling capacity	kW	158,1	169,9	196,0
Total absorbed power <sup>(1)</sup>		51,7	55,6	66,6
EER <sup>(1)</sup>		3,06	3,05	2,94
Maximum Colling Capacity	kg	166,1	179,3	209,1
EER at maximum capacity <sup>(1)</sup>		2,92	2,96	2,81
Minimum Cooling capacity :	kg	21,3	20,9	31,5
EER at minimum capacity <sup>(1)</sup>		2,04	1,05	1,42
Comfort Application	Seasonal Energy Efficiency Ratio <sup>(2)</sup> <b>SEER</b>	4,98	4,9	4,95
	Seasonal energy efficiency <sup>(3)</sup> <b>η<sub>s,c</sub></b>	196	193	195
Process Application	Seasonal Energy Performance Ratio <sup>(4)</sup> <b>SEPR - High temperature (7°C)</b>	5,93	5,69	5,46
	Seasonal Energy Performance Ratio <sup>(5)</sup> <b>SEPR - Medium temperature (-8°C)</b>	3,78	3,76	3,69
<b>Heating mode</b>				
Net Heating Capacity	kW	161,1	171,3	199,9
Total absorbed power <sup>(1)</sup>		49,9	53,6	65,3
COP		3,23	3,20	3,06
Maximum Heating capacity	kg	172,1	182,3	216,8
EER at maximum capacity <sup>(1)</sup>		3,14	3,12	2,93
Minimum Heating capacity	kg	21,1	20,6	31,2
EER at minimum capacity <sup>(1)</sup>		2,34	1,62	2,13
Comfort Application	Seasonal Coefficient of Performance <sup>(6)</sup> <b>SCOP</b>	3,9	3,88	3,93
	Seasonal energy efficiency <sup>(7)</sup> <b>η<sub>s,h</sub></b>	153	152	154
<b>Refrigeration circuit</b>				
Number of circuits		2	2	2
Refrigerant charge (circuit 1)	kg	13,5	13,6	13,8
Refrigerant charge (circuit 2)	kg	13,5	13,6	13,8
Refrigerant charge (total)	kg	27	27,2	27,6
Type of expansion valve		Electronic expansion valve		
<b>Compressors</b>				
Multi stage Scroll compressors				
Number of compressors		2+2	2+2	2+2
Type of expansion valve		Scroll (variable + fix) + tandem (fix + fix)	Scroll (variable + fix) + tandem (fix + fix)	Scroll (variable + fix) + tandem (fix + fix)
Capacity steps		Variable	Variable	Variable
Rotation Speed (RPM)		1200 - 7200		
Oil type		4MA POE R32 only		
Oil load	kg	2,51	2,51	2x2,51+1
<b>Condenser</b>				
Aluminium tubes and fins				
Number of condensers		1	1	1
<b>Condenser fan</b>				
Axial Fan				
Number of condenser fans		4	4	4
Nominal airflow rate	m <sup>3</sup> /h	61740	90118	90118
Rotation speed (rpm)		741 / 741	1003 / 1003	1003 / 1003
<b>Evaporator</b>				
Braze plate heat exchanger				
Number of evaporators		1	1	1
Nominal water flow rate	m <sup>3</sup> /h	27,28	29,31	33,8
Nominal pressure drop	kPa	26	26	34
Water volume	L			
Hydraulic service pressure without hydraulic module	kPa	1000		
<b>Hydraulic module (option)</b>				
Type of pump - Low or high pressure pump				
Stainless steel centrifugal single or twin pump mounted in parallel				
Expansion vessel volume	L	50		
Hydraulic service pressure with pump(s)	kPa	350		
Insulated water tank	L	400		
Hydraulic service pressure with pump(s) and water tank	kPa	350		
<b>Hydraulic connections</b>				
Type of standard connection				
Victaulic or Welded				
Inlet / Outlet connection diameters				
3"				
Inlet / Outlet external diameters				
88,9				
Type of optional connection				
Flange DN80				
<b>Electrical data</b>				
Power supply				
400V / 3 / 50Hz + E				
Maximum power	kW	71,7	81,6	94,8
Maximum running current	A	120	135,1	157,1
Starting current	A	276,3	338,5	398,3
Short circuit unit capacity	kA	10		
Power factor		0,84		
<b>Acoustic data</b>				
Global sound power level - Standard unit				
85,2				
Global sound power level				
82,3				
Low noise unit with acoustic jacket				
84,8				
87,5				
85,0				
<b>Dimensions</b>				
Length		2250	2250	2250
Width	mm	2650	2650	2650
Height with standard fan(s) and HIFP*		2071	2071	2071
Operating weight	kg	1360	1427	1427

- (1) EUROVENT certified data, in accordance with standard EN 14511 :  
Cooling mode : Evaporator water temperature = 12/7°C / Outdoor air temperature = 35°C  
Heating mode : Condenser water temperature = 40/45°C / Outdoor air temperature = 7°C
- (2) SEER in accordance with standard EN 14825.
- (3) Following ecodesign regulation EU 2016/2281 on space cooling, normalized leaving water temperature at 7°C, in accordance with standard EN 14825.
- (4) Following ecodesign regulation EU 2016/2281 on process cooling units, normalized leaving water temperature at 7°C, in accordance with standard EN 14825.

- (5) Following ecodesign regulation EU 2015/1095 on process cooling chillers, normalized leaving water temperature at -8°C, in accordance with standard EN 14825
- (6) SCOP in accordance with standard EN 14825. Heating mode performance is defined for average climate conditions.
- (7) Following ecodesign regulation EU 813/2013 on space heaters, normalized leaving water temperature at 35°C, in accordance with standard EN 14825, average climate conditions.
- (8) Following energy labelling regulation EU 811/2013 on space heaters.

FAN DATA

**GAC 035S - 040S - 045S  
GBC 040S**

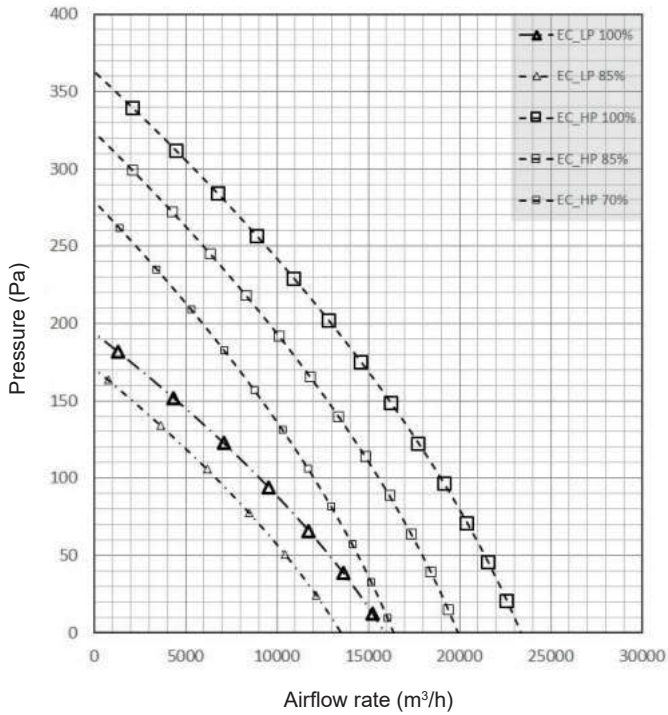

**GAH 035S - 040S - 045S  
GBH 040S**

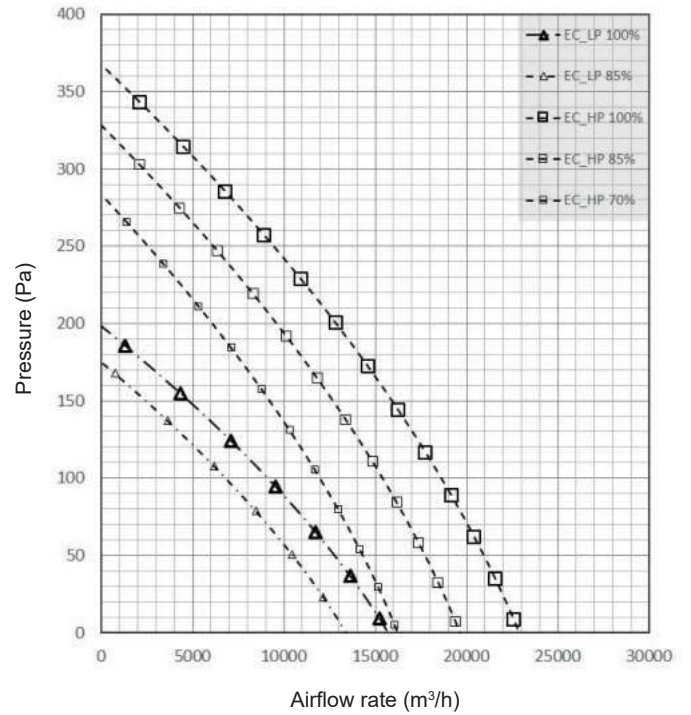

FAN DATA

**GAC 050S - 055S**

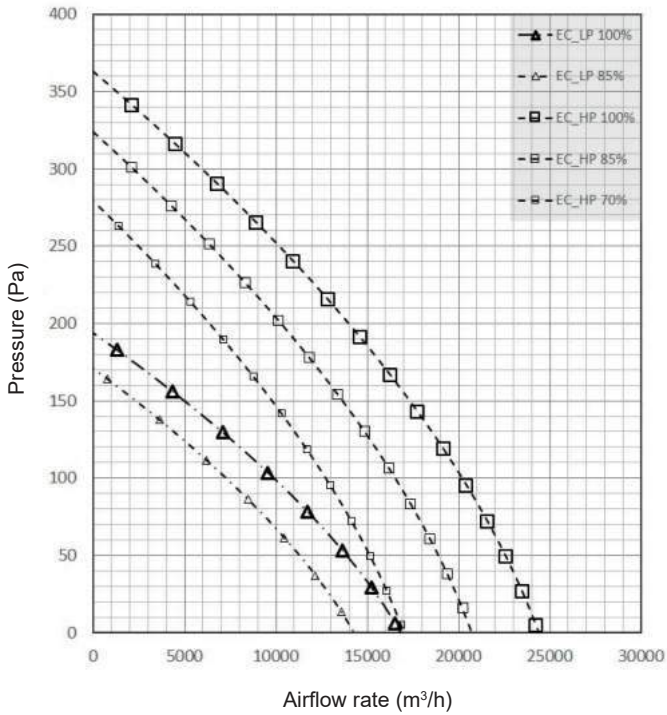

**GAH 050S**

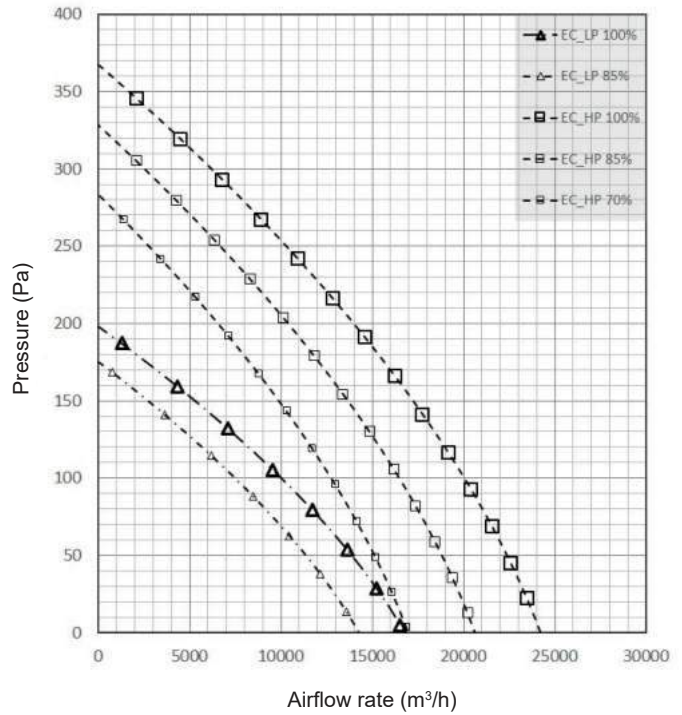

**GAC 060S  
GBC 060S**

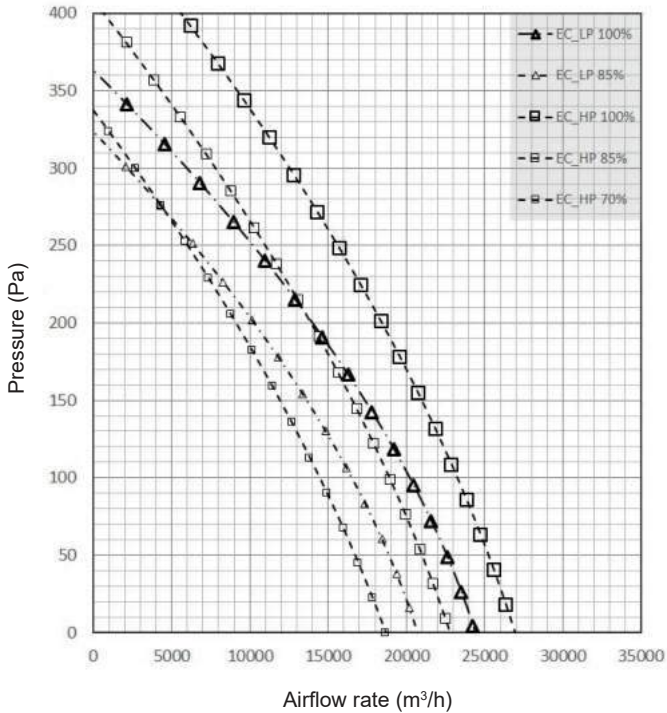

**GAH 055S - 060S  
GBH 060S**

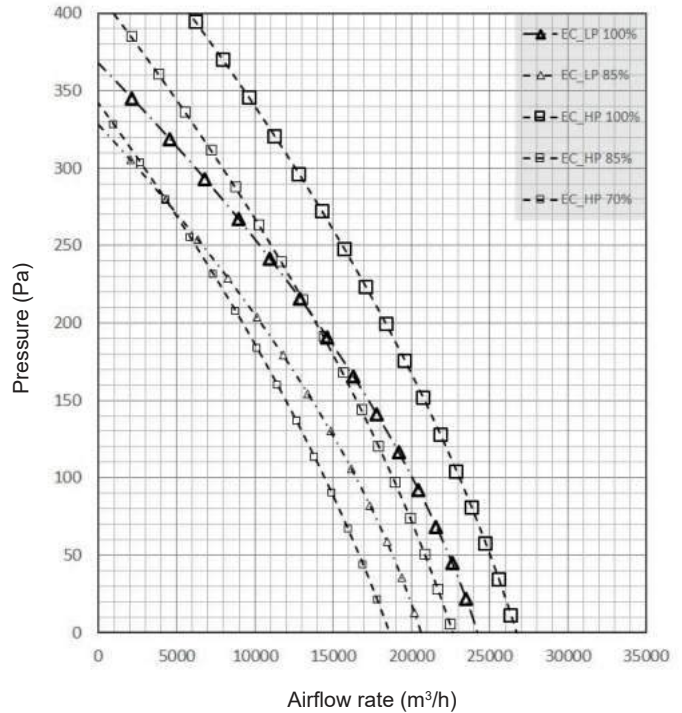

FAN DATA

**GAC 065S - 070S - 080S  
GBC 070S**

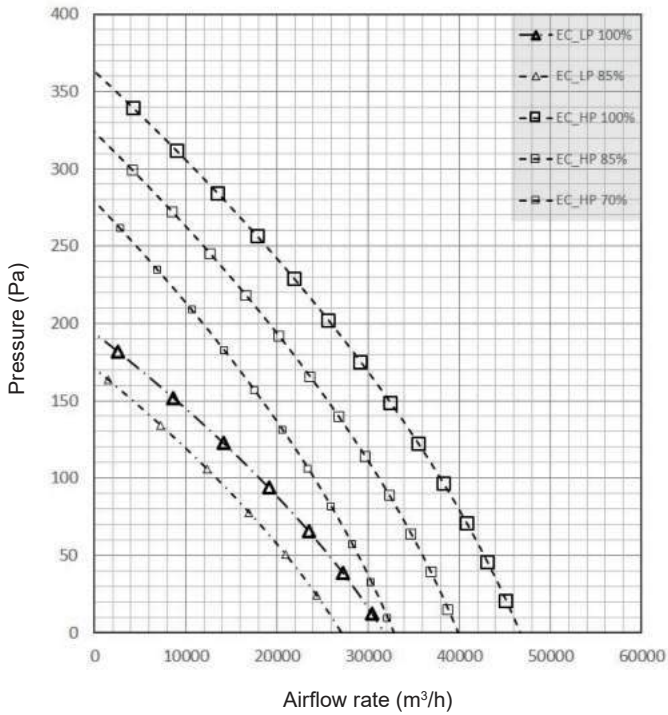

**GBC 080S**

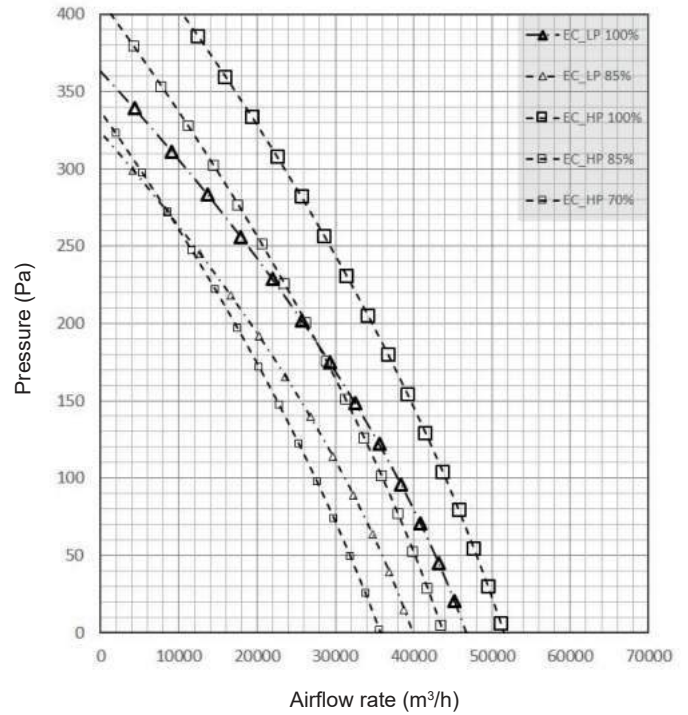

**GAH 065S - 070S - 080S  
GBH 070S**

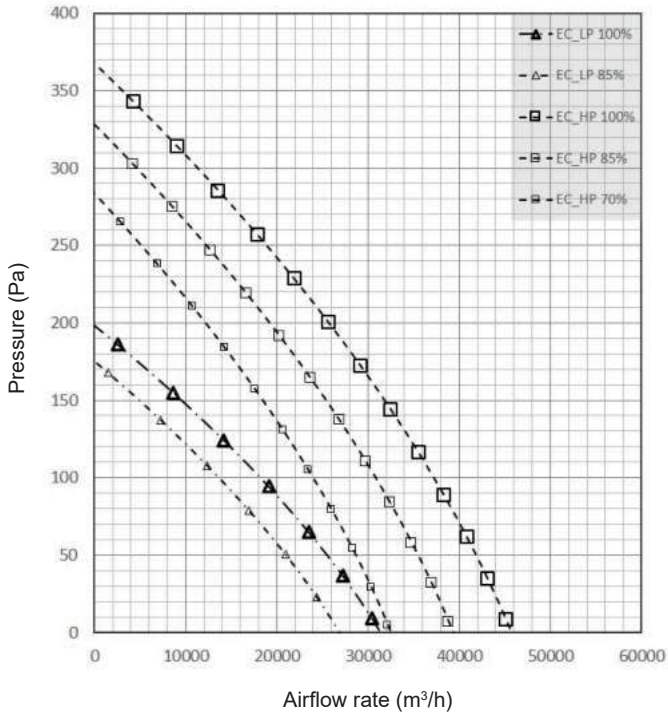

**GBH 080S**

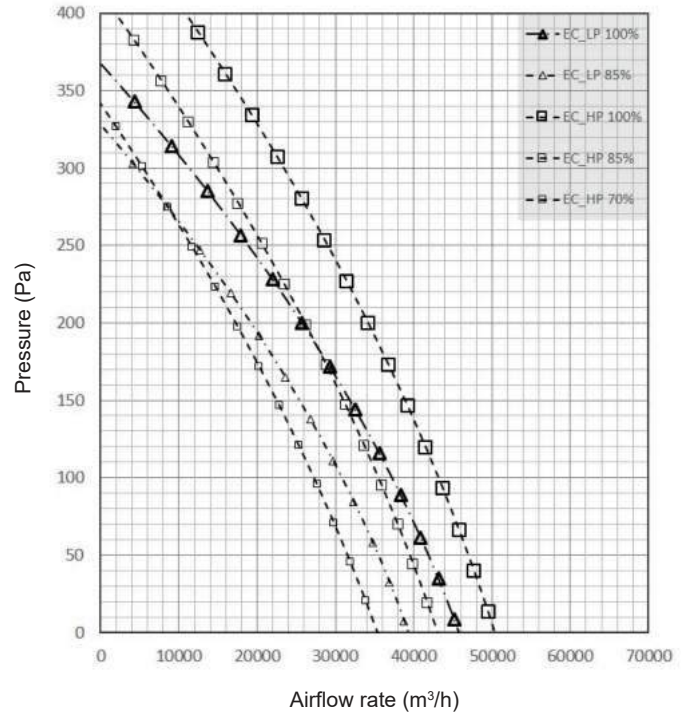

FAN DATA

**GAC 095S - 110S - 110D  
GBC 110S**

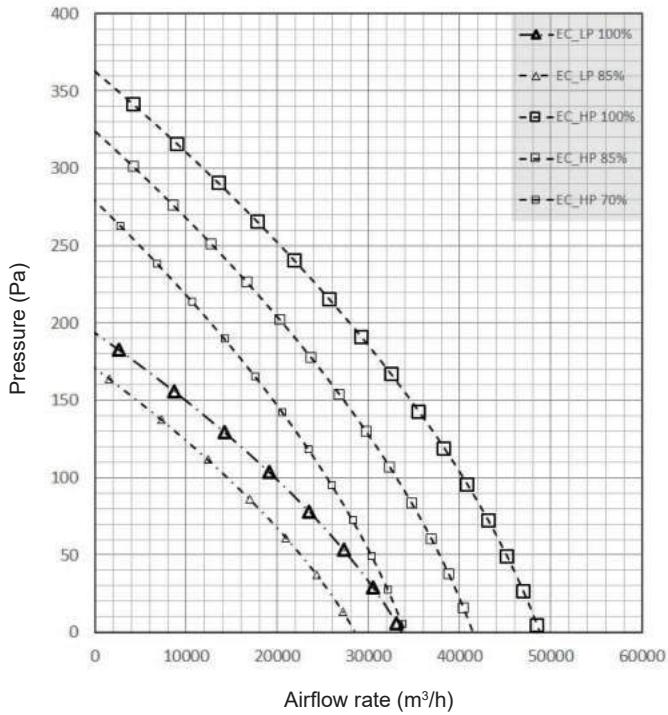

**GAH 095S - 110S - 110D  
GBH 110S**

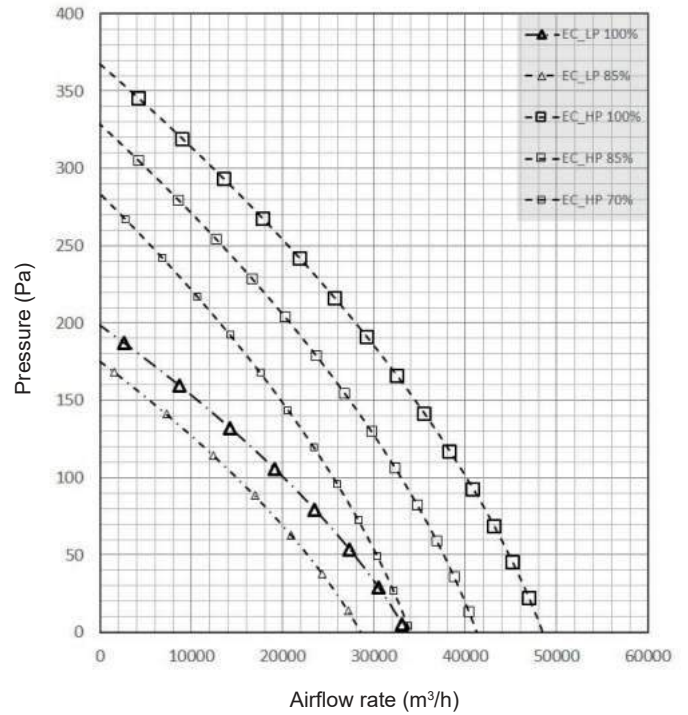

**GAC 115S - 125S - 125D  
GBC 120S - 125D**

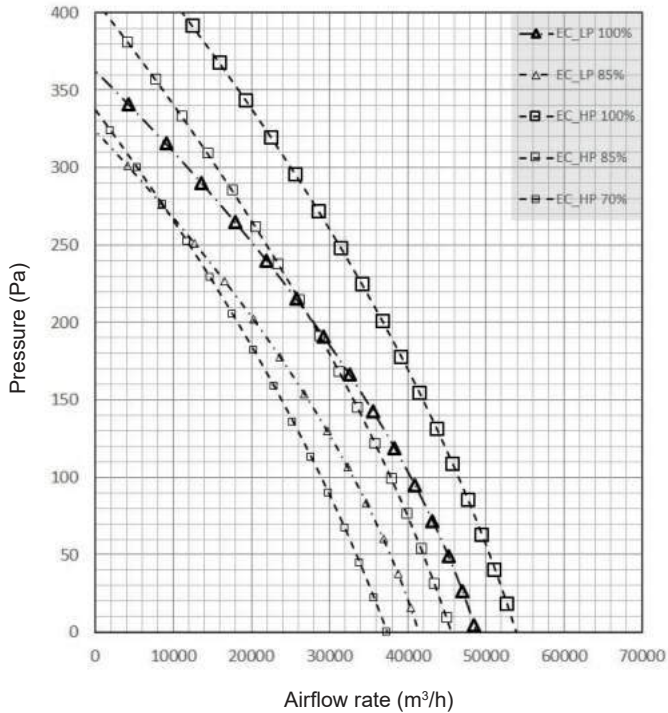

**GAH 115S - 125S - 125D  
GBH 120S - 125D**

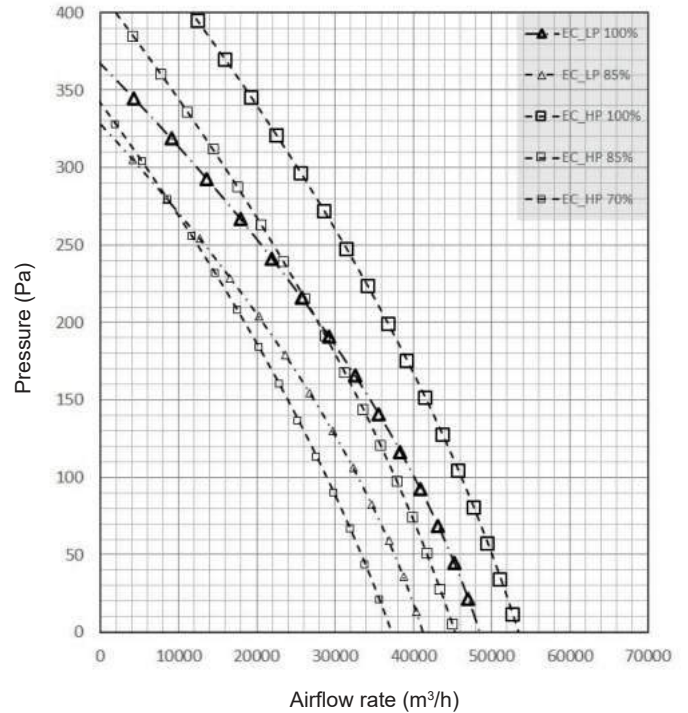

FAN DATA

**GAC 140S - 140D**  
**GBC 140D**

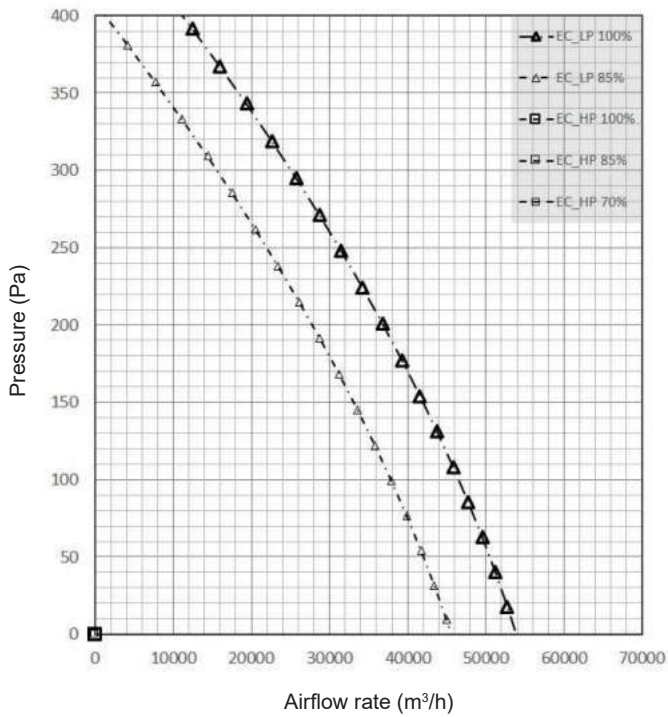

**GAH 140S - 140D**  
**GBH 140D**

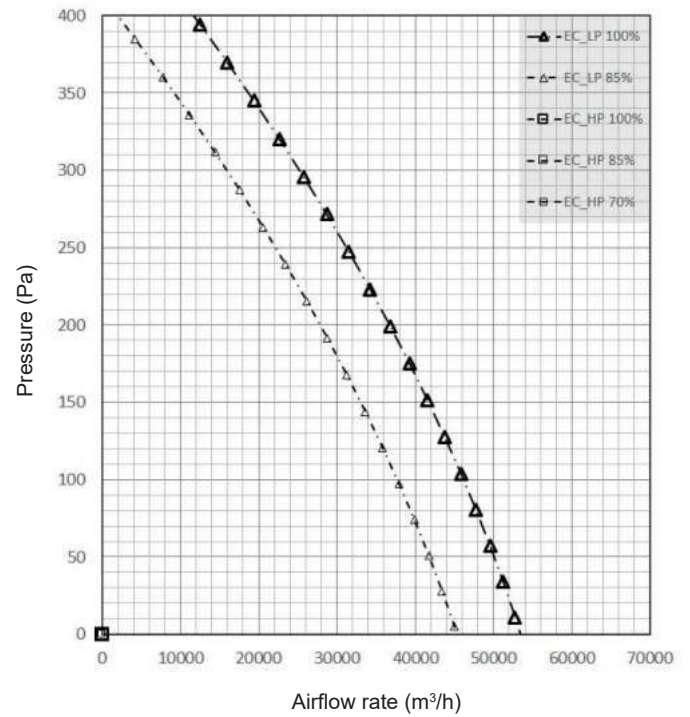

**GAC 160D**  
**GBC 160D**

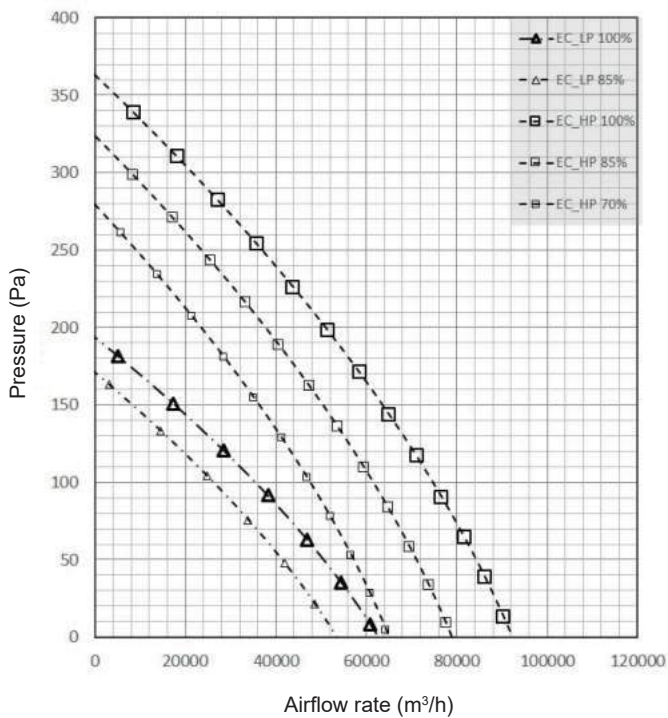

**GAH 160D**  
**GBH 160D**

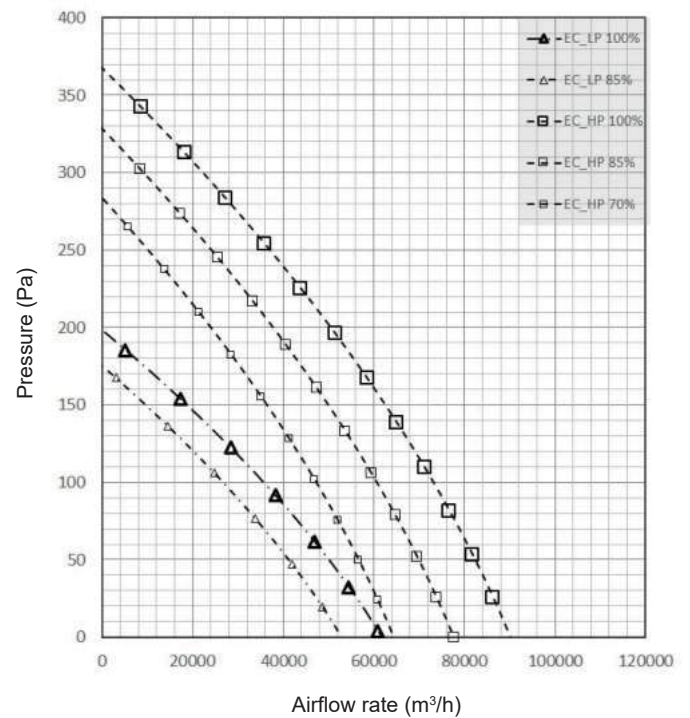

FAN DATA

**GAC 185D - 210D**  
**GBC 185D - 210D**

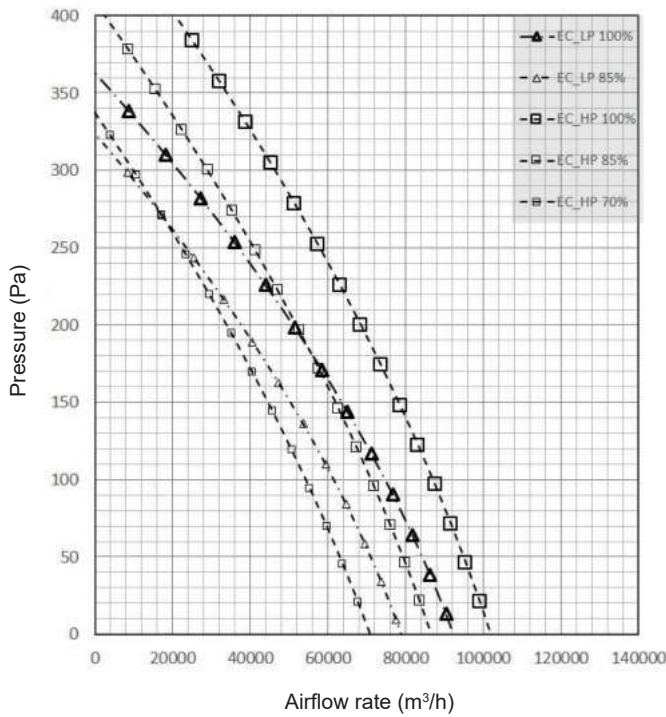

**GAH 185D - 210D**  
**GBH 185D - 210D**

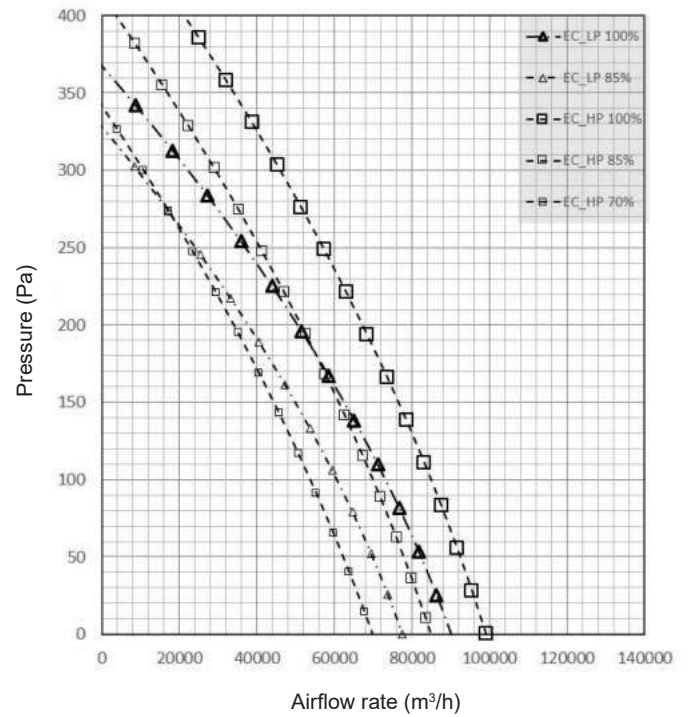

WATER PRESSURE DROPS



**INSTALLATION ADVICE**

The units **MUST** be fitted with a water filter at the inlet to the unit (trapping any particles with a diameter greater than 1 mm.)

**BASIC UNITS - PRESSURE DROP OF THE UNIT WITHOUT WATER FILTER**

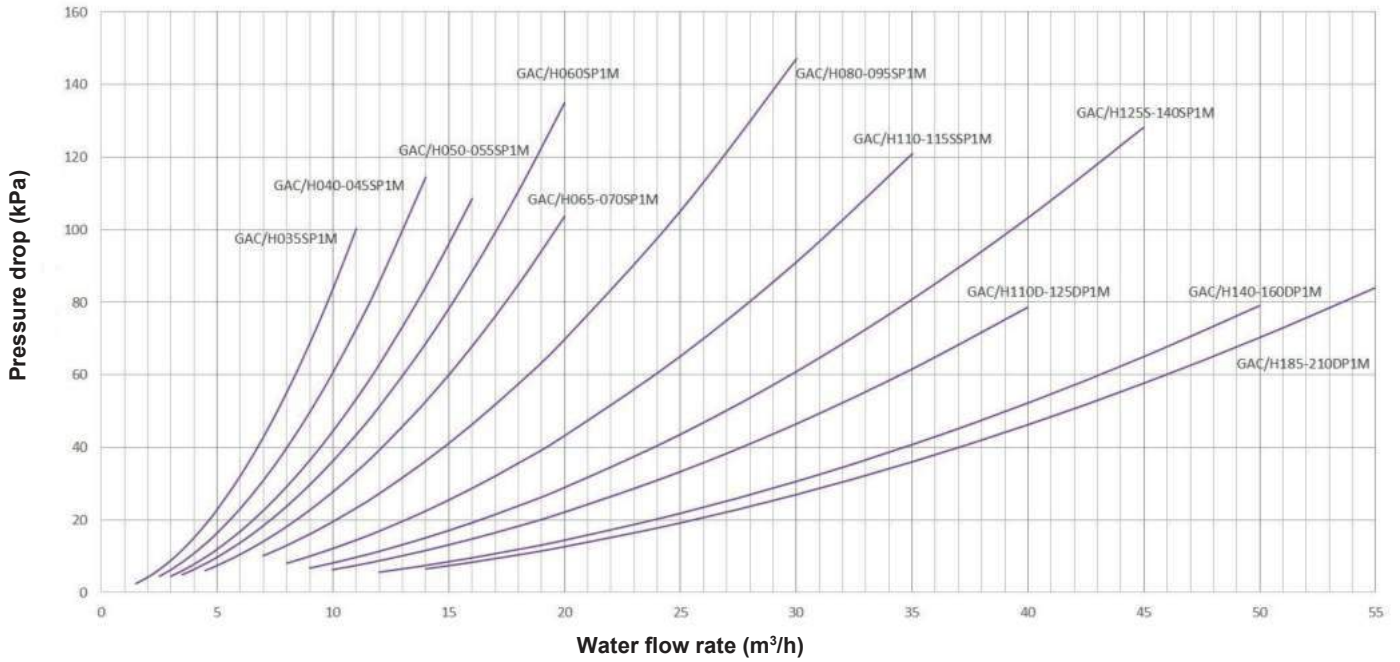

**BASIC UNITS - PRESSURE DROP FOR OPTION WATER FILTER**

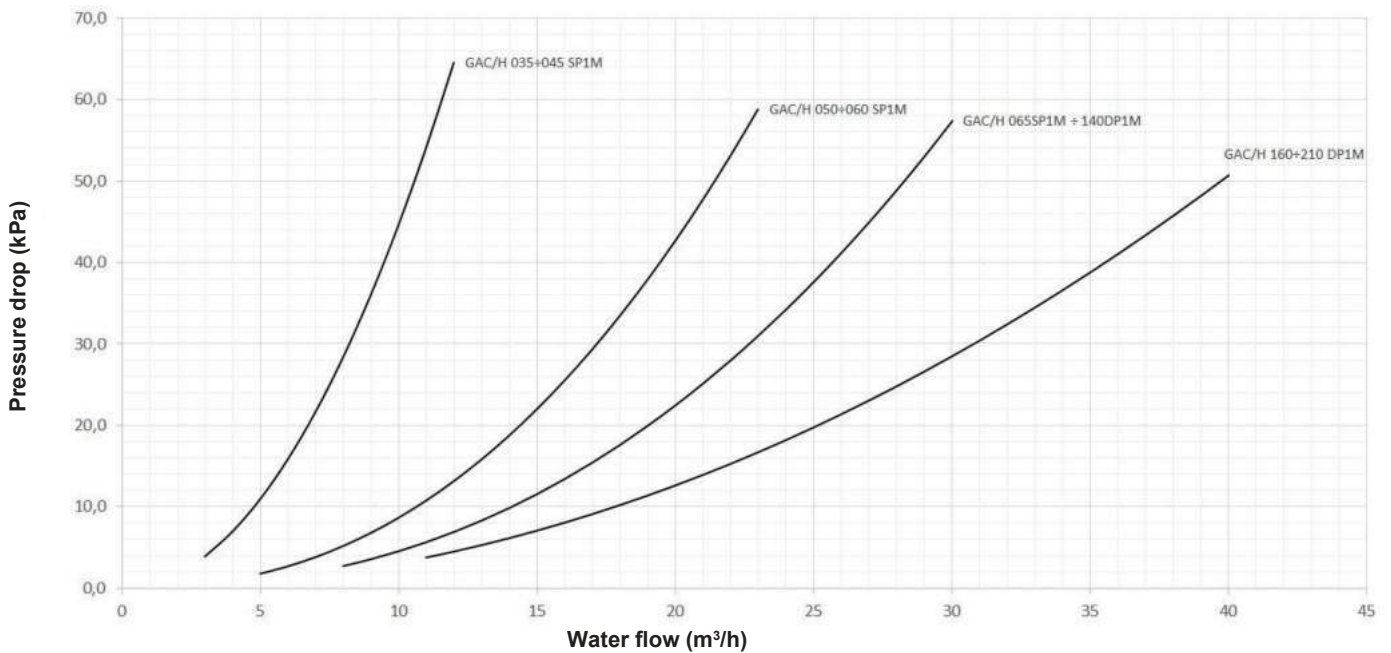

Filter included as standard.

## WATER PRESSURE DROPS



### INSTALLATION ADVICE

The units **MUST** be fitted with a water filter at the inlet to the unit (trapping any particles with a diameter greater than 1 mm.)

### ADVANCED UNITS - PRESSURE DROP OF THE UNIT WITHOUT WATER FILTER

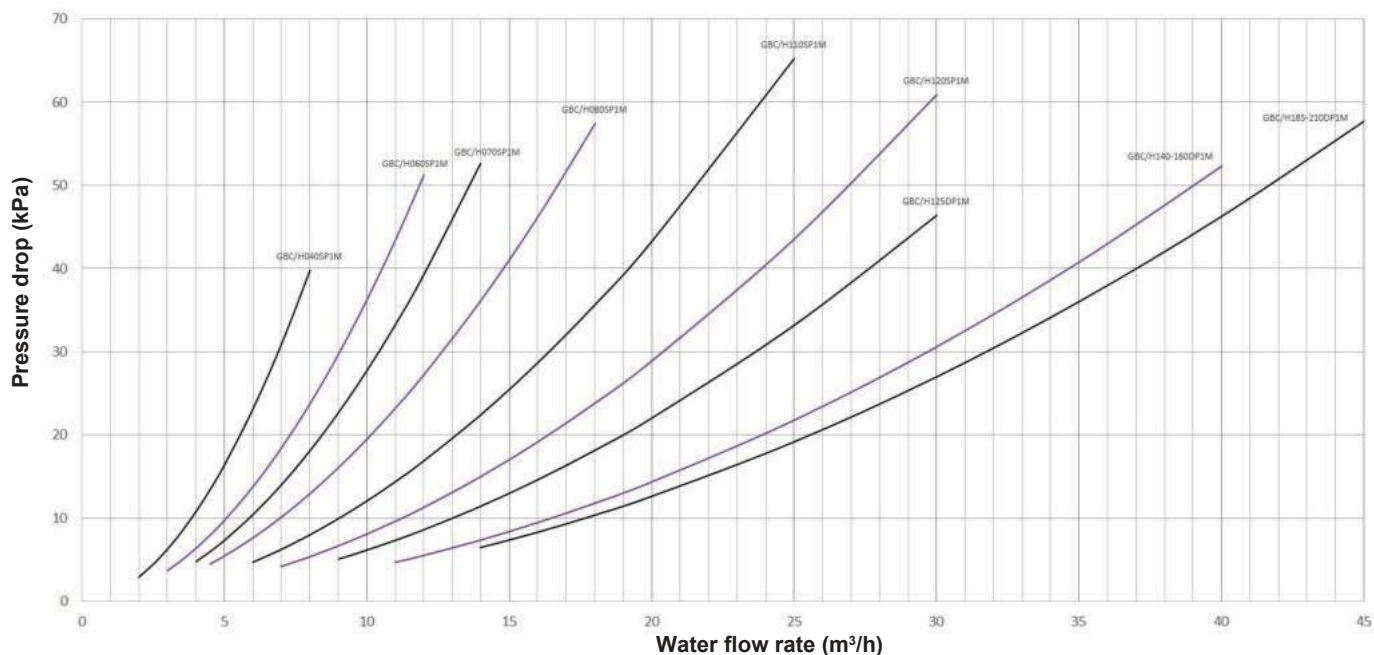

### ADVANCED UNITS - PRESSURE DROP FOR OPTION WATER FILTER

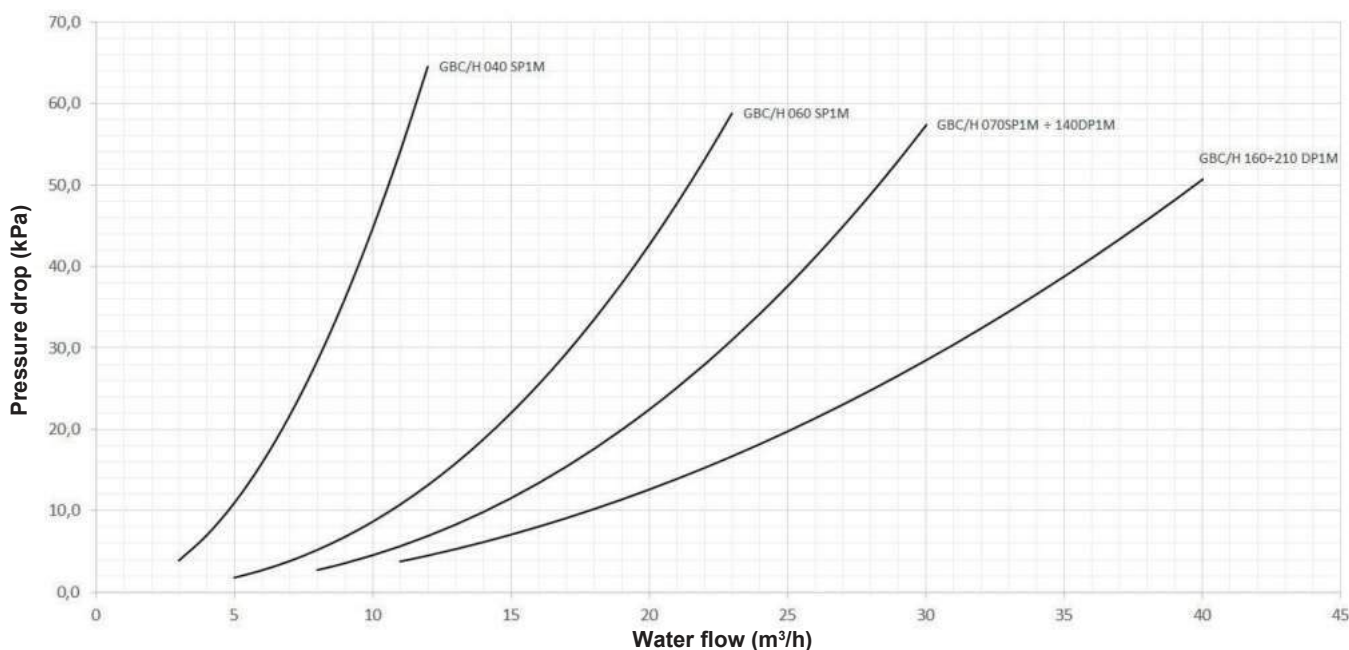

Filter included as standard.

## STANDARD UNIT

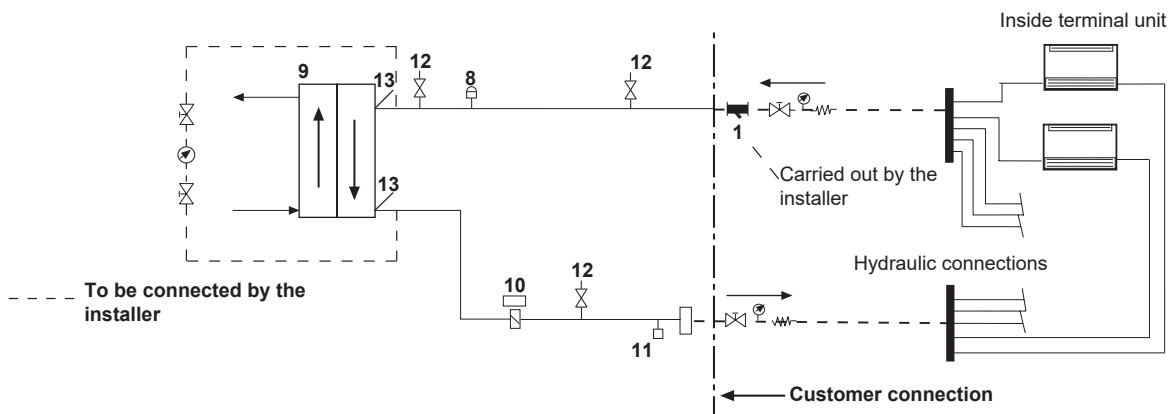

## UNIT WITH WATER PUMP OPTION

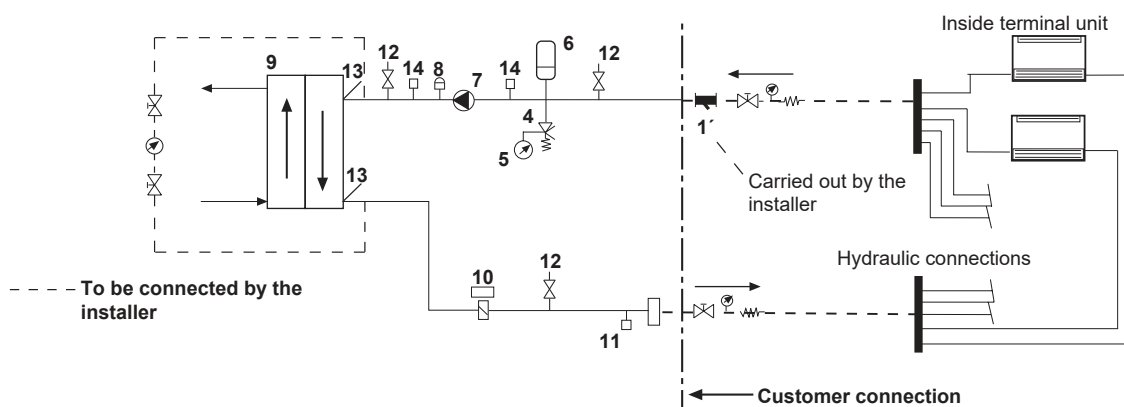

## UNIT WITH WATER TANK OPTION

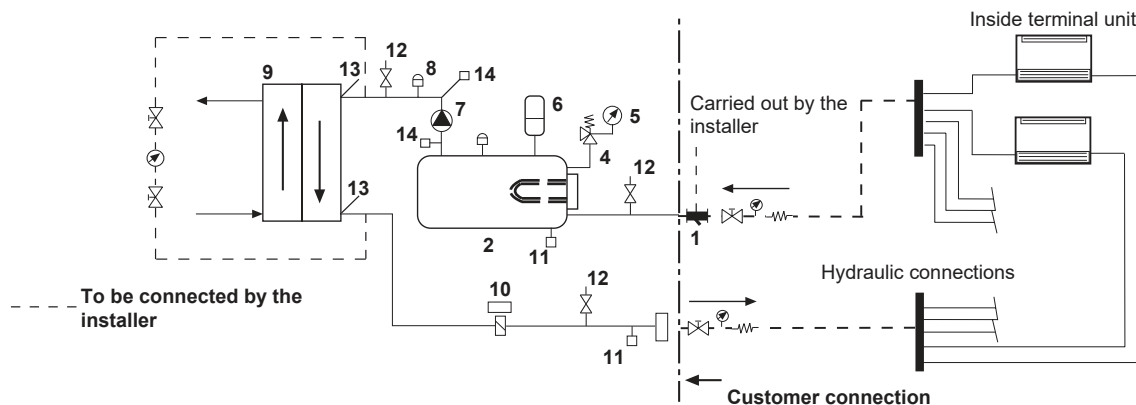

### COMPOSANTS :

VERSION STANDARD	UNITÉ AVEC POMPE À EAU (OPTION)	UNITÉ AVEC BALLON TAMPON (OPTION)
8, 9, 10, 11, 12, 13	4, 5, 6, 7, 8, 9, 10, 11, 12, 13, 14	2, 3, 4, 5, 6, 7, 8, 9, 10, 11, 12, 13, 14

1	Water filter (additional option, supplied loose)	6	Expansion vessel	11	Drain valve
2	Water tank	7	Water pump	12	Pressure tap
3	Water tank heater	8	Air purge valve	13	Water temperature sensor
4	Safety valve	9	Plate exchanger	14	Pressure transducer (when variable water flow option is selected)
5	Pressure gauge	10	Flow switch		

The use of a water filter in the circuit upstream of the heat exchanger is mandatory. These filters must remove all particles with a diameter greater than 1 mm, and must be positioned within 1 meter of the inlet of the exchanger. They may be supplied as an option by the manufacturer.

WATER PUMPS DATA

**GAC/H 035S**

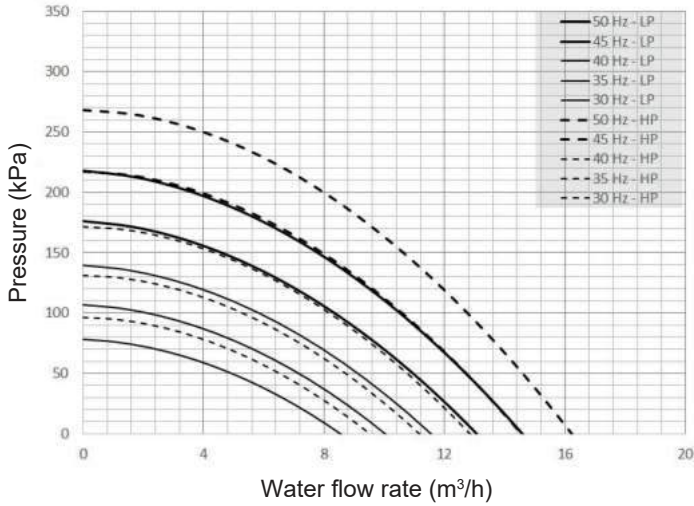

**GAC/H 040S - GAC 045S  
GBC/H 040S**

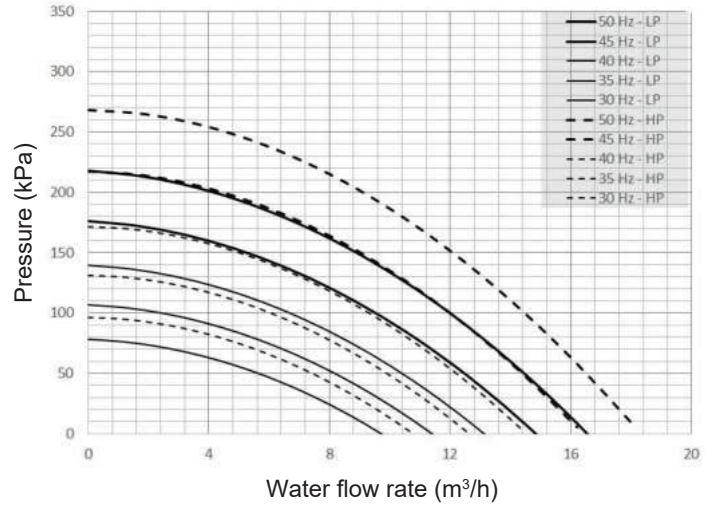

**GAH 045S - GAC/H 050S - GAC 055S**

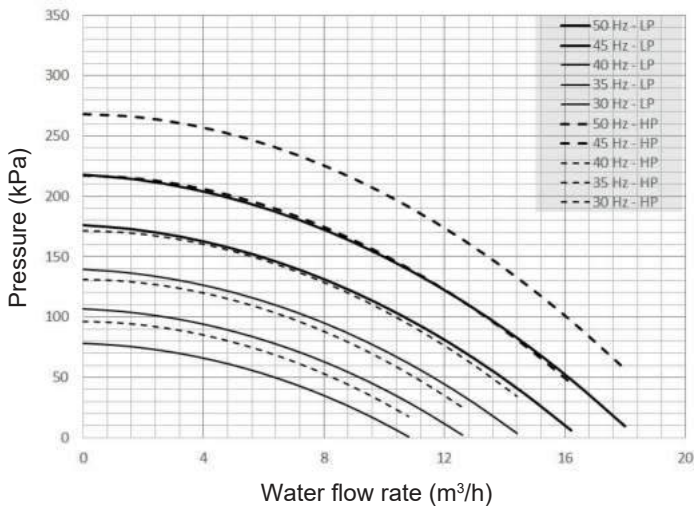

**GAH 055S - GAC 060S  
GBC 060S**

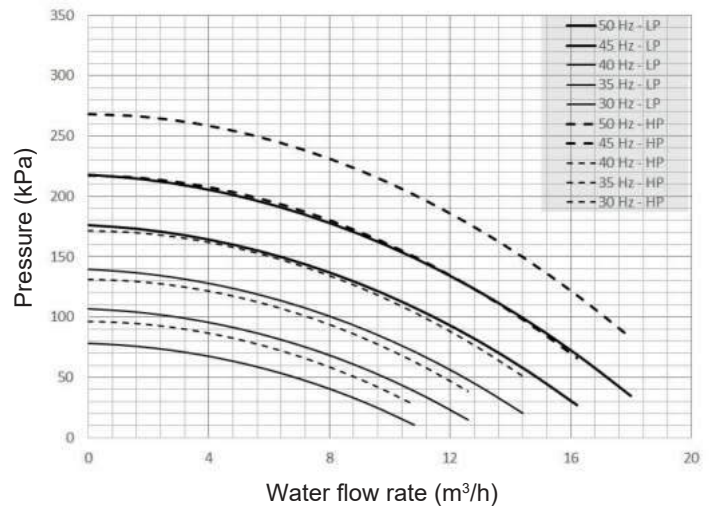

WATER PUMPS DATA

**GAH 060S  
GBH 060S**

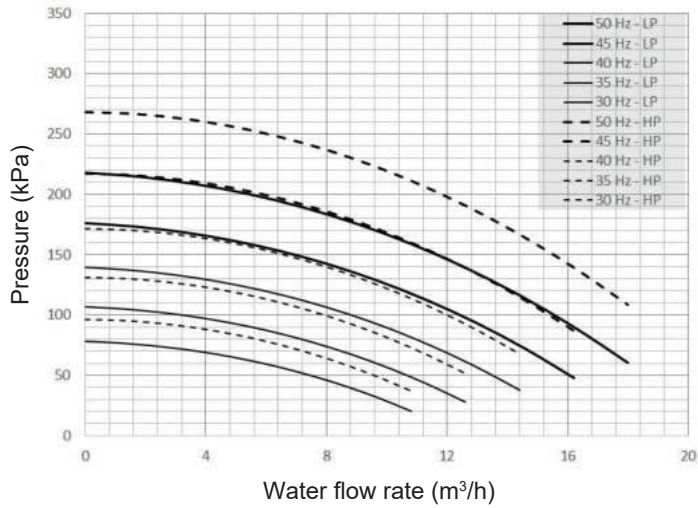

**GAC/H 065S - 070S  
GBC/H 070S**

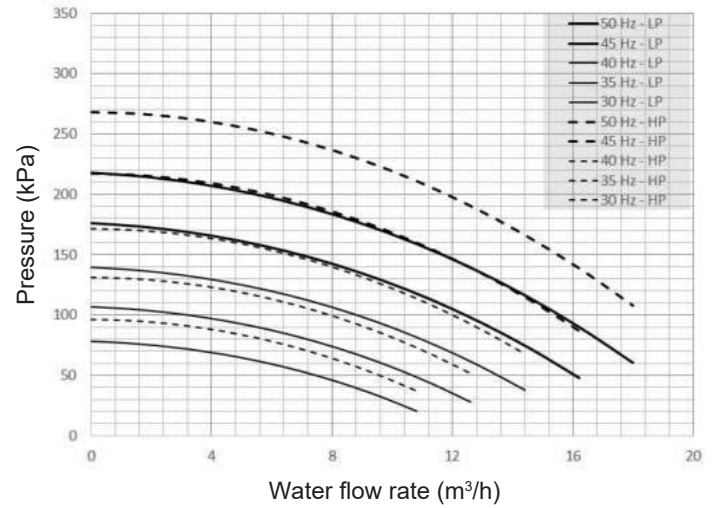

**GAC/H 080S  
GBC/H 080S**

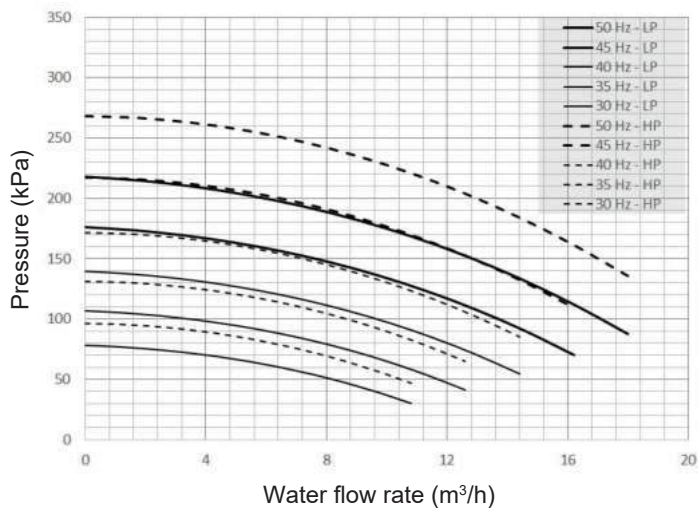

**GAC/H 095S**

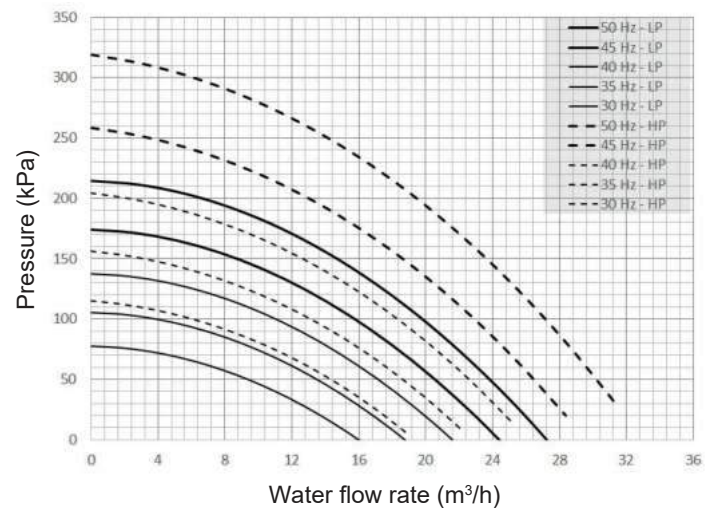

WATER PUMPS DATA

**GAC/H 110S - 115S  
GBC/H 110S**

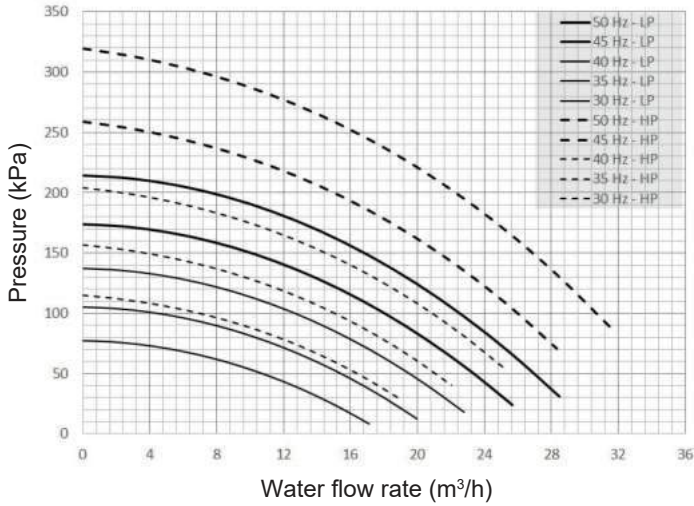

**GAC/H 125S - 140S  
GBC/H 120S**

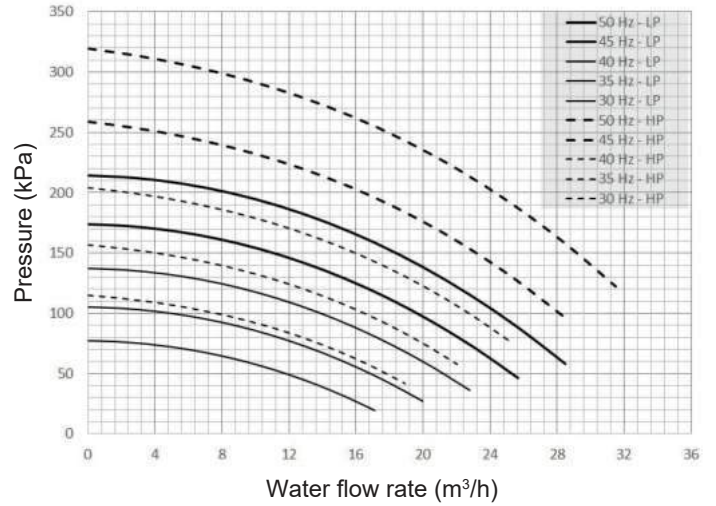

**GAC/H 110D - 125D  
GBC/H 125D**

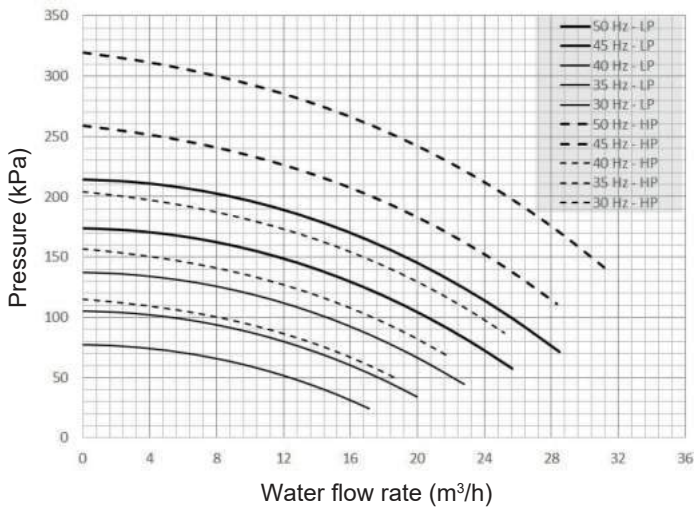

**GAC/H 140D  
GBC/H 140D**

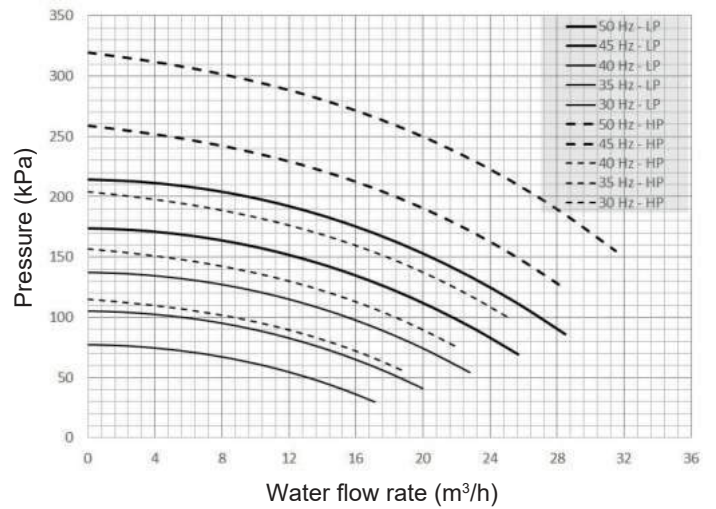

WATER PUMPS DATA

**GAC/H 160D  
GBC/H 160D**

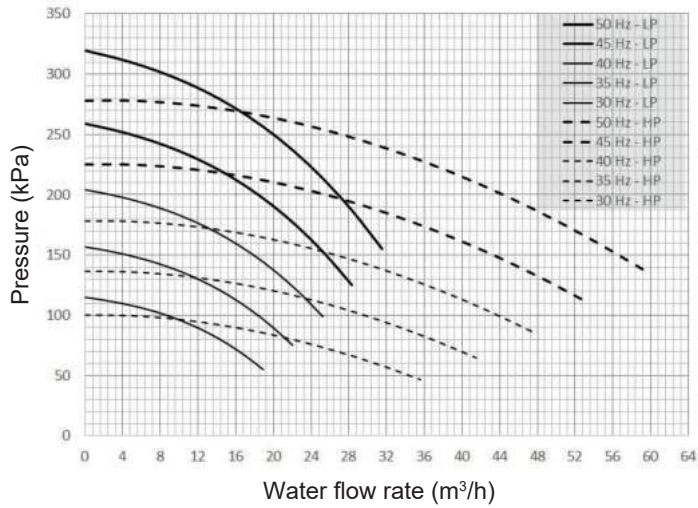

**GAC/H 185D - 210D  
GBC/H 185D - 210D**

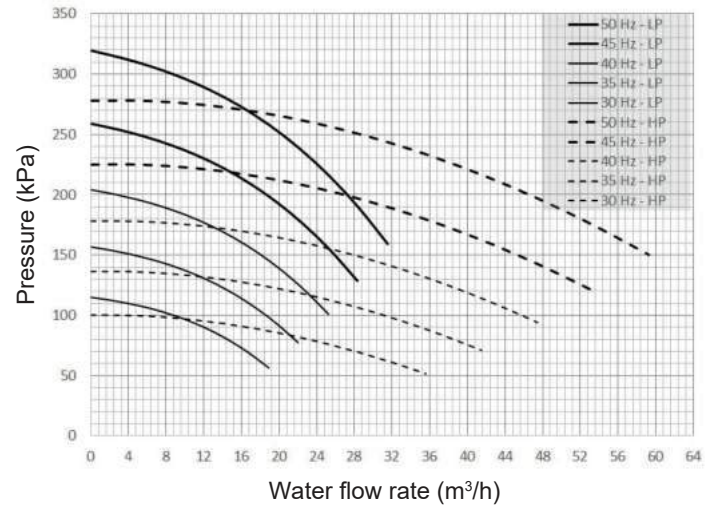

GLYCOL SOLUTION UNIT

If the outside temperature where the system is to be installed or the water outlet temperature is likely to drop below 5°C, it is very important to use glycol anti-freeze.

The amount of anti-freeze required will vary depending on the minimum ambient temperature or the water outlet temperature. When the percentage of glycol increases the standard pump flow decreases, the pressure drop increases and the cooling and thermal capacities drop. As a result the minimum flow must be multiplied by the coefficient shown in the table:

	Minimum ambient temperature or water outlet temperature			
	+ 5°C → 0°C	0 °C → - 5°C	-5°C → - 10°C	- 10°C → - 15°C
Ethylene glycol %	10%	20%	30%	35%
Pressure drop	1,05	1,10	1,15	1,18
Water flow	1,02	1,05	1,08	1,10
Power input	0,997	0,996	0,995	0,994
Capacities Cooling mode	0,995	0,985	0,975	0,965
Capacities Heating mode	0,994	0,993	0,99	0,987

**Example : 10 % glycol**

Pressure drop : 210 x 1,05  
 Minimum flow : 12,38 m³/h x 1,02  
 System capacity x 0,99

WATER VOLUME

**MINIMUM WATER VOLUME IN THE INSTALLATION**

Thanks to an intelligent algorithm and short cycle protection of compressors, eCOMFORT can operate with low volumes of water. The water volume of the installation (piping + exchangers) must be capable of storing the energy supplied by the chilled water cooler or the heat pump during the minimum operating time. When this volume is insufficient, a buffer tank must be installed.

The minimum capacity in liters of water of the whole installation is then expressed by the following formula :

$$\text{Minimum water loop volume (litre)} = \frac{\text{Minimum capacity stage (kW)} \times \text{Minimum operating time (s)} \times 1000}{\text{Water density (1000 kg/m}^3\text{)} \times \text{Water specific heat (4,18 kJ/Kg.}^\circ\text{C)} \times \text{Acceptable temperature deviation (}^\circ\text{C)}}$$

This formula may be simplified that way :

$$\text{Minimum water loop volume (litre)} = \text{Water density (1000 kg/m}^3\text{)} \times \frac{\text{Minimum capacity stage (kW)} \times \text{Minimum operating time (s)} \times 1000}{\text{Acceptable temperature deviation (}^\circ\text{C)}}$$

## HYDRAULIC EQUIPMENT

Size	Nominal cooling capacity	Minimum capacity stage	Minimum water loop of the installation (litres)			GAC Water volume with tank option	GAH Water volume with tank option
	kW	%	(acceptable deviation = 6°C)	(acceptable deviation = 4°C)	(acceptable deviation = 2°C)	Liters	Liters
<b>E-COMFORT</b>							
<b>035S</b>	38	50	92	138	276	104	104
<b>040S</b>	42	50	99	149	298	105	105
<b>045S</b>	48	50	114	170	341	105	105
<b>050S</b>	52	46	114	171	342	105	105
<b>055S</b>	55	60	158	237	474	105	106
<b>060S</b>	64	44	134	201	402	106	107
<b>065S</b>	64	44	135	203	406	182	182
<b>070S</b>	70	40	134	201	402	182	182
<b>080S</b>	86	50	206	310	619	182	182
<b>095S</b>	96	44	202	302	605	183	183
<b>110S</b>	108	38	197	295	591	185	185
<b>115S</b>	119	44	251	377	753	185	185
<b>125S</b>	129	33	203	304	609	262	262
<b>140S</b>	155	33	244	367	733	262	262
<b>110D</b>	111	25	133	200	400	262	262
<b>125D</b>	128	22	134	201	403	262	262
<b>140D</b>	142	20	136	204	408	266	266
<b>160D</b>	168	25	201	301	602	416	416
<b>185D</b>	187	22	197	295	591	418	418
<b>210D</b>	211	19	191	287	574	418	418
<b>E-COMFORT ADVANCED</b>							
<b>040S</b>	35	25	41	62	124	105	105
<b>060S</b>	51	25	61	92	184	106	107
<b>070S</b>	62	13	38	57	115	180	180
<b>080S</b>	77	11	41	61	122	180	180
<b>110S</b>	95	13	59	88	176	183	183
<b>120S</b>	117	10	56	84	168	262	262
<b>125D</b>	125	6	36	54	107	262	262
<b>140D</b>	147	5	35	53	105	266	266
<b>160D</b>	160	5	38	57	114	341	341
<b>185D</b>	170	5	41	61	122	343	343
<b>210D</b>	197	6	56	85	169	343	343

Note: In cases where the unit operates with a low volume of water with an air handling unit or if the unit is used for industrial processes, the buffer tank is essential (see the section on hydraulic options). For heat pump applications, we also recommend using a buffer tank to maintain a stable temperature during defrost cycles. In addition, the eCOMFORT unit equipped with modulating immersion heaters in the balloon guarantees and secures the thermal.

### MAXIMUM WATER VOLUME IN THE INSTALLATION

The units with hydraulic module include a expansion vessel. The table below details the maximum water volume in the system.

If the water volume in the system is greater than that detailed in the table, it will be necessary to add additional expansion vessel(s).

The system design must allow for water expansion and contraction.

Models	035S ▶ 060S	065S ▶ 140D	160D ▶ 210D
Volume of the expansion vessel (liters)	18	35	50
Refrigerant	Maximum water volume in Liters		
WATER	775	1500	2145
WATER + 10% glycol	560	1150	1640
WATER + 20% glycol	490	950	1430
WATER + 30% glycol	420	860	1240
WATER + 35% glycol	310	650	950

## MINIMUM WATER FLOW THROUGH THE EVAPORATOR

**In case of installation with fixed speed pump, to prevent from freezing risk, the flow rate through the evaporator must be higher than the minimum flow given in the table below.**

In case of variable primary flow, the pump speed must be controlled through the eCLIMATIC control. Additionally, the hydraulic system must be properly designed and balanced to ensure a right water flow distribution through the chiller evaporator and the terminal units.

This is especially important when the system is designed with fan coils equipped with two-way valves. When the two-way valves are closing in response to building load change, it is important that the system is designed to ensure a minimum evaporator flow that is always minimum 60% of the chiller's design flow rate. This can be done with a bypass from chilled water supply to chilled water return opened via a signal from a flow meter.

Additionally, some terminals can be fitted with three way control valves in order to ensure the flow will not drop below the minimum value at any load condition as indicated in the table below.

Size	Water flow rate(m3h)						Water content (Liter)		
	Minimum		Nominal		Maximum		Unit without buffer tank	Buffer tank	
	GAC	GAH	GAC	GAH	GAC	GAH		GAC	GAH
035S	3,28	3,25	6,55	6,49	10,87	10,77	3,928	100	100
040S	3,6	3,54	7,21	7,09	11,96	11,77	4,538	100	100
045S	4,08	4,03	8,15	8,07	13,53	13,39	4,538	100	100
050S	4,44	4,34	8,88	8,69	14,73	14,42	5,27	100	100
055S	4,73	4,82	9,46	9,65	15,71	16,01	5,27	100	100
060S	5,41	5,44	10,83	10,87	17,98	18,05	-	-	-
065S	5,41	5,53	10,83	11,06	17,98	18,35	7,356	173	173
070S	5,83	5,99	11,65	11,98	19,34	19,88	7,356	173	173
080S	6,86	7,29	13,71	14,57	22,77	24,19	7,358	173	173
095S	7,56	8,09	15,13	16,19	25,11	26,87	7,858	173	173
110S	8,74	9,06	17,49	18,12	29,03	30,07	9,676	173	173
115S	9,46	10,15	18,92	20,29	31,41	33,68	9,676	173	173
125S	10,36	10,87	20,71	21,74	34,38	36,09	11,696	250	250
140S	12,51	13,07	25,01	26,14	41,52	43,4	11,696	250	250
110D	9,38	9,34	18,75	18,68	31,13	31,01	11,99	250	250
125D	10,58	10,77	21,17	21,55	35,14	35,77	11,99	250	250
140D	11,86	12,07	23,71	24,13	39,37	40,06	15,77	250	250
160D	13,95	14,28	27,91	28,56	46,33	47,41	16,27	325	325
185D	15,72	16,11	31,44	32,21	52,19	53,47	17,89	325	325
210D	17,66	17,99	35,32	35,97	58,64	59,71	17,89	325	325

Size	Water flow rate(m3h)						Water content (Liter)		
	Minimum		Nominal		Maximum		Unit without buffer tank	Buffer tank	
	GBC	GBH	GBC	GBH	GBC	GBH		GBC	GBH
040S	2,97	2,89	5,94	5,78	7,72	7,51	4,538	100	100
060S	4,41	4,3	8,83	8,61	11,47	11,19	6,856	100	100
070S	5,29	5,21	10,58	10,43	13,75	13,55	7,356	173	173
080S	6,66	6,19	13,32	12,37	17,31	16,08	7,356	173	173
110S	8,13	7,54	16,26	15,07	21,14	19,59	9,676	173	173
120S	10,06	9,39	20,12	18,78	26,15	24,42	11,696	173	173
125D	10,73	10,62	21,47	21,25	27,91	27,62	11,99	250	250
140D	12,62	12,39	25,24	24,78	32,81	32,22	15,77	250	250
160D	13,72	13,6	27,44	27,2	35,67	35,36	16,27	325	325
185D	14,62	14,61	29,23	29,23	38	38	17,89	325	325
210D	16,91	16,85	33,82	33,71	43,96	43,82	17,89	325	325

**EDRIVE TECHNOLOGY, THE RIGHT CHOICE TO SAVE 75% OF PUMP ENERGY COSTS**

LENNOX offers the eDrive, a variable speed drive pump option (with single or double pump) which modulates the water flow through the evaporator and reduces energy costs. This option is available on chillers and heat pumps from 20 to 1000 kW.

In a water system, one major contributor to annual energy consumption is the pump motor. Pumping energy cost can represent 20% of the total cost of owning a chiller. This ratio can be even higher for a heat-pump.

**eDrive™ variable speed driven pump is contributing to continuous Lennox efforts to save energy while exploring possibilities to reduce installation cost.**

eDrive™ variable speed driven pump benefits:

- Cost savings on the energy consumption especially at part-load conditions and during off period.
- 75% of this energy could be saved !
- Cost savings on the initial system cost. Fewer pumps and piping connections than primary-secondary systems, terminal units equipped with two-way control valves instead of three-way valves, elimination of water flow set valve.
- Flexibility and accuracy in the pump operation control (smooth start and stop, gradual change of speed, accuracy and stability of control)
- Reduction of the repeated stress on the pump and piping resulting in longer equipment life time (elimination of the «hammer blow» in pipes).
- Elimination of the start-up current thanks to variable frequency drive that controls a gradual pump motor supply.

Designing a variable primary flow chilled water plant that performs reliably at all load conditions requires careful attention to chiller design. Thanks to the newest generation of chiller controllers and intensive testing, eCOMFORT can reliably maintain the desired chilled water temperature with a flow range from 60% to 100% that gives up to 75% annual energy savings.

LENNOX eDrive™ Technology modulates the Water Flow especially in Part-Load Conditions through a Specific Algorithm and a Variable Frequency Driver.

TYPICAL COST SPLIT IN A CHILLER THROUGH 15-YEAR LIFESPAN

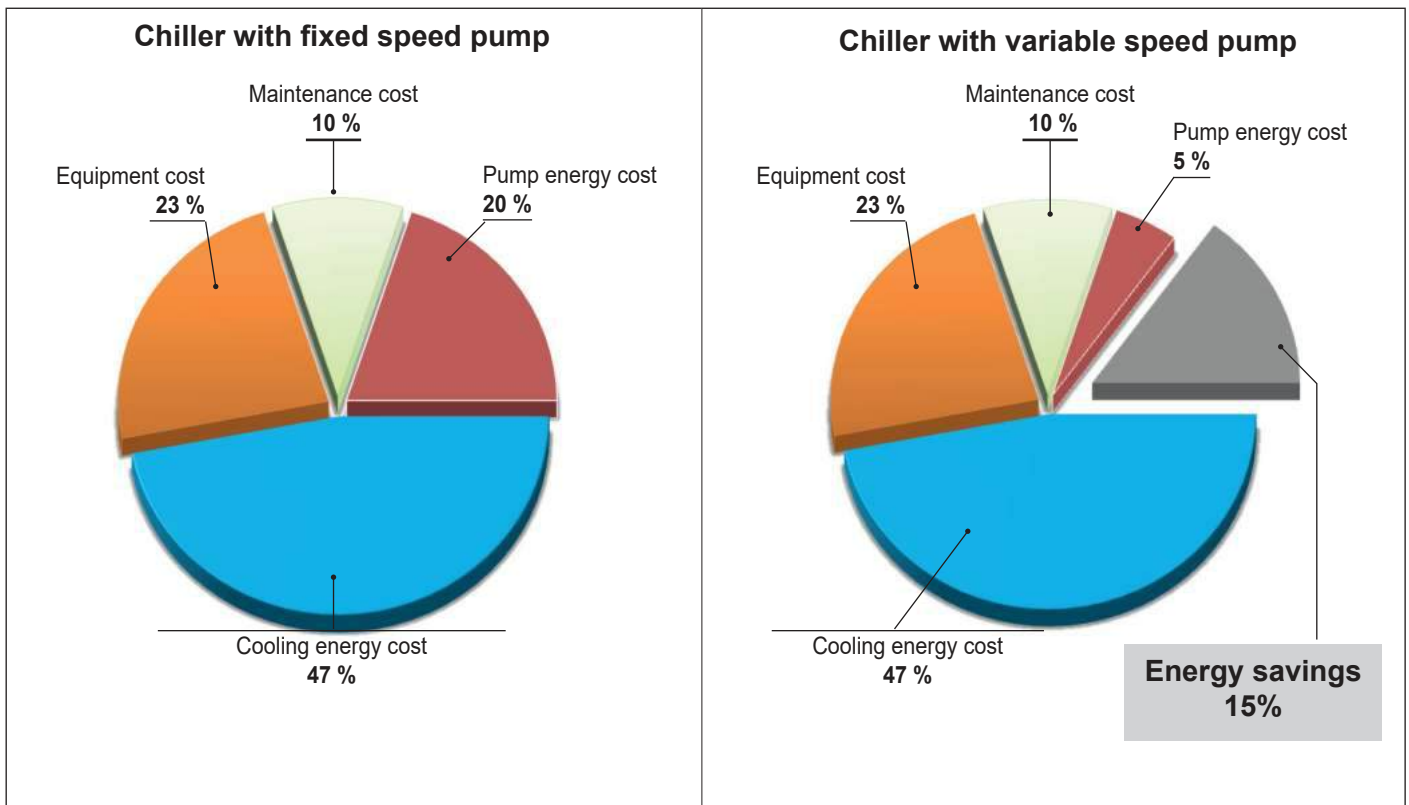

EDRIVE™ VARIABLE WATER FLOW SAVES YOUR MONEY IN THE ENERGY COST

- Through the elimination of the energy normally lost in the water flow control valve during unit full-load operation (Variable water flow = perfect pump curve adjustment to the required nominal water flow and delta P)
- Through pump rotation speed reduction during unit part-load operation.
- Thanks to pump running at minimum speed during Chiller “off” period (night, unoccupied)

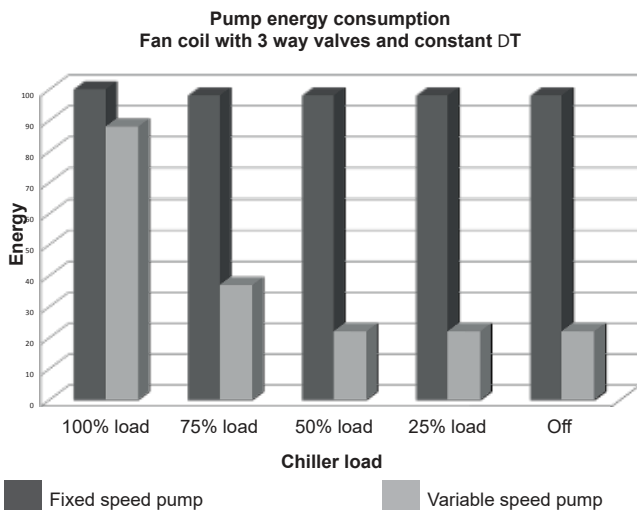

**PUMP AFFINITY LAWS**

“The power required for pumps varies as the cube of the flow rate.”

20% water flow reduction = 50% energy reduction.  
40% water flow reduction = 80% energy reduction.

## EDRIVE VARIABLE WATER FLOW MAY SAVE MONEY IN THE SYSTEM DESIGN COST

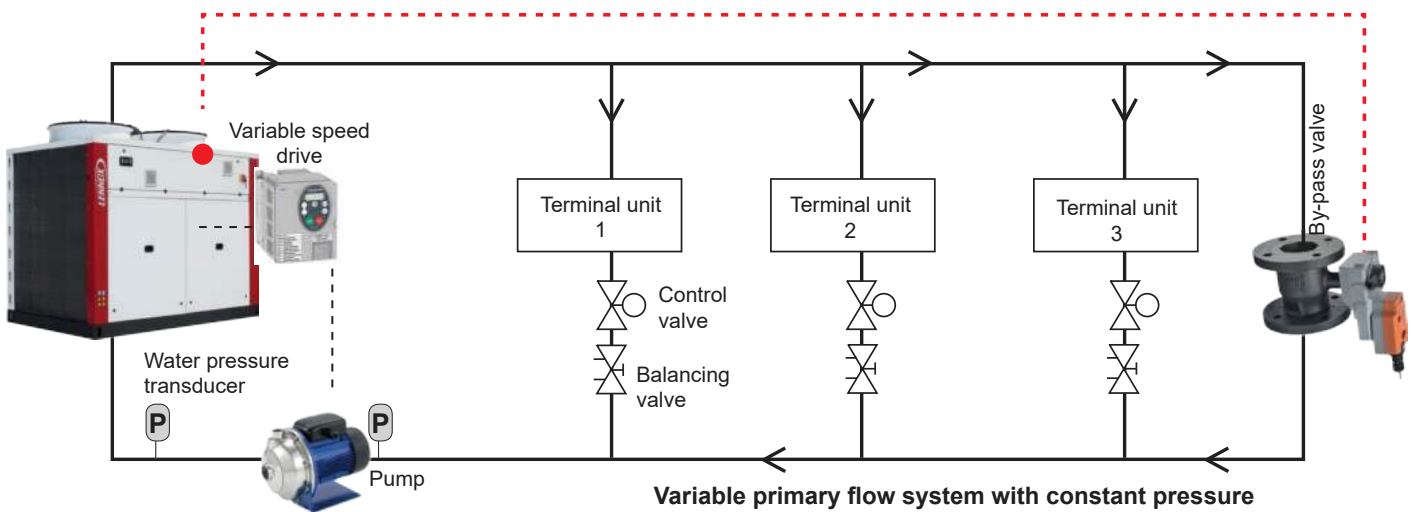

A variable primary flow design uses fewer components than primary-secondary systems as the pumps of the secondary distribution loop and the mixing tank are eliminated. When compared with constant primary flow systems, terminal units can be equipped with two-way control valves instead of three-way valves often used in constant volume systems. Using two-way valves instead of three-way valves on fan coils represent a budget reduction that pays for the variable frequency driver cost. On top of that, the water flow set valve is eliminated as the pump adjustment to real installation needs can be done electronically. These factors may reduce the initial cost of the chilled water system.

## EDRIVE VARIABLE WATER FLOW BY LENNOX

### 3 CONTROL MODES AVAILABLE :

#### Constant speed / Dead zone

- Interest to set the right installation design flow (avoid setting valve).

#### Constant Delta P (setting to declare the required working pressure)

- Easy to install and operate with 2 way valves installation.

#### Constant Delta T (Setting to declare the required delta T)

- Need a good installation with well balanced circuits to ensure good flow distribution when the flow is reduced.
- Installation with terminal units fitted with 3-way valves.

### OPERATION FOR EACH MODE:

- **Constant speed / dead zone :** eDrive pilots the pump to the water flow desired when the compressors are in operation. When the compressors are stopped (dead zone), control will automatically reduce the speed of the pump to the minimum water flow. This minimum flow is also adjustable within minimum 30Hz (60% flow).
- **Constant delta P :** the eDrive™ regulation is managing the pump to maintain the required delta P in order to keep constant the customer available static pressure. When the terminals control valves close in response to decreased building loads, the pump controller slows the pump speed to maintain the target delta P. In this mode the pump does not detect terminal capacity reduction (fan speed staging)
- **Constant Delta T :** the eDrive™ regulation is managing the pump to maintain the required Delta T. When the Delta T is increasing in response to the number of compressors running, the pump controller increases the speed of the pump. Conversely, when the compressors are stopping in response to decreased building loads, the pump controller slows the pump speed to maintain the target Delta T.

### SAFETY PARAMETERS:

- If the evaporating pressure reaches the low limit (risk of evaporator frosting), the flow is increased.
- If the outlet evaporator temperature reaches the low limit, the flow is set to the maximum.
- When the pump speed varies and the flow switch trips, the flow is automatically increased.
- During defrost procedure (HP), the flow is set to the maximum.
- Pump motor supply range from 30 Hz minimum to 50Hz maximum. Minimum pump motor frequency set at 30Hz. Below this value, risk of pump motor failure due to overheat.
- For safe operation of the chiller, the unit is protected by the flow switch.

- Minimum and maximum admissible water flow per unit size: with constant delta T, the flow may vary from 60% to 100% of the selected pump nominal flow.
- Maximum change in flow rate through the evaporator: a 10% per minute change in flow rate is admissible in most of air conditioning applications.

### Installation instructions to respect in case of variable primary flow:

- The hydraulic system will have to be properly designed and balanced to ensure a right water flow distribution through the chiller evaporator and the terminal units.
- The hydraulic system will have to be properly designed to respect minimum and maximum water flow through each chiller following the values given by the manufacturer.

### Case of constant Delta P mode :

- In case of system designed with terminal units equipped with 2 way valves, the hydraulic system will need to have a bypass flow to ensure a minimum water flow through the chiller evaporator.
- By-pass method :
  - Bypass adequate water flow can be achieved with a slow modulating opening as soon as the water flow rate is near the minimum. When the water flow rises according to predefined setting, this valve closes. This bypass modulating valve provided by LENNOX as an option is controlled by our eClimatic control. The bypass should be positioned at the beginning of the installation near the unit and allows significant energy savings and cost as opposed to a location at the end of the system.
  - An alternative is to install some 3-way valves at different points of the terminal units. This approach allows constant minimum flow in the chiller or heat pump and ensures a cheaper system.
- The minimum water flow through the chiller evaporator will need to respect a minimum value that is 60% of the nominal chiller water flow.
- The flow bypass from chilled water supply to chilled water return can be done with a motorized bypass valve opened via a signal from a flow meter.
- For safe operation some terminals can be equipped with three way control valves in order to ensure the flow will not drop below the minimum value at any load condition.
- The water flow must not vary by more than 10% per minute.
- Check the control valve authority in low load periods, especially in case of long pipe hydraulic systems.

### OPERATING WEIGHT OF ADDITIONAL OPTION (KG)

Hydraulic module GAC/GAH	035S	040S	045S	050S	055S	060S	065S	070S	080S	095S
With low-pressure single pump	16,5	21,4	21,4	26,4	26,4	26,4	26,4	26,4	26,4	27,6
With low-pressure twin pump	33	42,8	42,8	52,8	52,8	52,8	52,8	52,8	52,8	55,2
With high-pressure single pump	22,9	22,9	22,9	27,9	27,9	27,9	27,9	27,9	27,9	31
With high-pressure twin pump	45,8	45,8	45,8	55,8	55,8	55,8	55,8	55,8	55,8	62
With eDrive low-pressure single pump	18,5	23,4	23,4	28,4	28,4	28,4	28,4	28,4	28,4	29,6
With eDrive low-pressure twin pump	24,9	24,9	24,9	29,9	29,9	29,9	29,9	29,9	29,9	34,3
With eDrive high-pressure single pump	35	44,8	44,8	54,8	54,8	54,8	54,8	54,8	54,8	57,2
With eDrive high-pressure twin pump	47,8	47,8	47,8	57,8	57,8	57,8	57,8	57,8	57,8	65,3
Water tank	145	145	145	295	295	295	295	295	295	360

Hydraulic module GAC/GAH	110S	115S	125S	140S	110D	125D	140D	160D	185D	210D
With low-pressure single pump	27,6	27,6	27,6	27,6	27,6	27,6	36	36	36	36
With low-pressure twin pump	55,2	55,2	55,2	55,2	55,2	55,2	72	72	72	72
With high-pressure single pump	31	31	31	31	31	31	57	57	57	57
With high-pressure twin pump	62	62	62	62	62	62	114	114	114	114
With eDrive low-pressure single pump	29,6	29,6	29,6	29,6	29,6	29,6	39,3	39,3	39,3	39,3
With eDrive low-pressure twin pump	34,3	34,3	34,3	34,3	34,3	34,3	60,3	60,3	60,3	60,3
With eDrive high-pressure single pump	57,2	57,2	57,2	57,2	57,2	57,2	75,3	75,3	75,3	75,3
With eDrive high-pressure twin pump	65,3	65,3	65,3	65,3	65,3	65,3	117,3	117,3	117,3	117,3
Water tank	360	360	360	360	360	360	580	580	580	580

Hydraulic module GBC/GBH	040S	060S	070S	080S	110S	120S	125D	140D	160D	185D	210D
With eDrive low-pressure single pump	23,4	28,4	28,4	28,4	29,6	29,6	29,6	39,3	39,3	39,3	39,3
With eDrive low-pressure twin pump	24,9	29,9	29,9	29,9	34,3	34,3	34,3	60,3	60,3	60,3	60,3
With eDrive high-pressure single pump	44,8	54,8	54,8	54,8	57,2	57,2	57,2	75,3	75,3	75,3	75,3
With eDrive high-pressure twin pump	47,8	57,8	57,8	57,8	65,3	65,3	65,3	117,3	117,3	117,3	117,3
Water tank	145	295	295	295	360	360	360	580	580	580	580

## DESUPERHEATER : PARTIAL HEAT RECOVERY

On eCOMFORT units from 90 to 210 kW, an additional plate heat exchanger (water / refrigerant) on each circuit allows a 20 to 25% recovery of the heat rejected. This heat exchanger is sized to recover heat for the production of free hot water up to 70 °C.

Typical applications for heat recovery are installations with high demand for hot water :

- for domestic use, such as hospitals and hotels
- for industrial use.

This option is available on both cooling only and heat pump versions. Heat recovery can only be applied when the unit is operating (either in cooling or in heating mode).

GAC with Desuperheater option		GAC 095S	GAC 110S	GAC 115S	GAC 125S	GAC 140S	GAC 110D	GAC 125D	GAC 140D	GAC 160D	GAC 185D	GAC 210D
Cooling Capacity	kW	95,8	111,4	108,3	119,3	127,5	128,6	142,3	154,8	167,8	187,2	210,5
Heat recovery capacity		21	28	25,6	24,7	28,6	27,6	31,5	37,3	38	38,2	46
Water flow rate	m <sup>3</sup> /h	3,63	4,83	4,42	4,26	4,93	4,76	5,43	6,44	6,55	6,59	7,94
Exchanger pressure drop	kPa	9,7	6,3	11	10,2	6,5	12,7	7,9	22,7	8	7	10,1
Water Volume	dm <sup>3</sup>	1,296	1,566	1,566	1,566	1,566	2,052	2,052	2,052	2,592	2,862	2,862
Connection diameters Inlet / Outlet		1" 1/2										

GAH with Desuperheater option		GAH 095S	GAH 110S	GAH 115S	GAH 125S	GAH 140S	GAH 110D	GAH 125D	GAH 140D	GAH 160D	GAH 185D	GAH 210D
Cooling Capacity	kW	94,1	108,6	105,3	118	125,3	126,4	140,3	152	166,1	187,3	209,1
Heating capacity without recovery mode		94,8	114	106,7	117,5	129,3	126,1	142,5	154,5	170,7	190,3	216
Heating capacity in recovery mode		52,8	61,4	57,6	65,4	71,4	71	78,7	84	93,8	107	117,1
Heat recovery capacity		42	52,6	49,1	52,1	57,9	55,1	63,8	70,5	76,9	83,3	98,9
Water flow rate	m <sup>3</sup> /h	7,24	9,07	8,47	8,99	9,99	9,5	11,01	12,17	13,26	14,37	17,05
Exchanger pressure drop	kPa	36,4	21	38,4	43	25,3	47,9	30,5	77,1	30,7	31,4	43,7
Water Volume	dm <sup>3</sup>	1,296	2,052	1,566	1,566	2,052	1,566	2,052	1,566	2,592	2,862	2,862
Connection diameters		1" 1/2										

<b>GBC with Desuperheater option</b>		<b>GBC 110S</b>	<b>GBC 120S</b>	<b>GBC 125D</b>	<b>GBC 140D</b>	<b>GBC 160D</b>	<b>GBC 185D</b>	<b>GBC 210D</b>
Cooling Capacity	kW	94,6	117	124,8	146,7	159,5	170	196,6
Heat recovery capacity		23	27,8	30,8	37,2	38,7	37,9	46,6
Water flow rate	m <sup>3</sup> /h	0,6	0,73	0,81	0,97	1,01	0,99	1,22
Exchanger pressure drop	kPa	0,2	0,3	0,2	0,3	0,2	0,2	0,3
Water Volume	dm <sup>3</sup>	1,566	1,566	2,052	2,052	2,592	2,862	2,862
Connection diameters Inlet / Outlet		1" 1/2						

<b>GBH with Desuperheater option</b>		<b>GBH 110S</b>	<b>GBH 120S</b>	<b>GBH 125D</b>	<b>GBH 140D</b>	<b>GBH 160D</b>	<b>GBH 185D</b>	<b>GBH 210D</b>
Cooling Capacity	kW	87,6	109,2	123,5	144,1	158,1	169,9	196
Heating capacity without recovery mode		94	116,5	126,8	146,9	161,1	171,3	199,9
Heating capacity in recovery mode		69,2	85,7	92,6	106,5	117,7	126,5	146,2
Heat recovery capacity		24,8	30,8	34,2	40,4	43,4	44,8	53,7
Water flow rate	m <sup>3</sup> /h	4,28	5,31	5,9	6,97	7,48	7,73	9,26
Exchanger pressure drop	kPa	10,3	15,6	9,2	12,7	10,3	9,6	13,5
Water Volume	dm <sup>3</sup>	1,566	1,566	2,052	2,052	2,592	2,862	2,862
Connection diameters		1" 1/2						

**DESUPERHEATER : OPERATING LIMITS**

Minimum outlet water temperature	°C	25
Maximum outlet water temperature		70
Minimum difference water inlet / outlet		3
Maximum difference water inlet / outlet		15

# SOUND POWER LEVEL



GAC GAH	Spectrum per octave band (dB)								Global sound power Lw dB(A)
	63 Hz	125 Hz	250 Hz	500 Hz	1000 Hz	2000 Hz	4000 Hz	8000 Hz	
035S	73,5	62,3	60,7	65,8	72,8	67,8	65,5	59,2	75,3
040S	73,5	62,3	60,4	66,4	71,7	68,2	67,8	59,6	75,3
045S	73,5	62,3	62,8	64,3	70,1	67,0	67,8	62,8	74,4
050S	73,5	62,3	62,9	64,0	70,2	68,1	68,5	62,4	74,9
055S	73,5	62,4	62,9	63,7	70,3	69,0	69,1	62,0	75,3
060S	76,9	68,6	67,9	70,9	73,4	73,1	70,5	64,6	78,6
065S	76,6	65,4	64,0	68,4	72,6	72,6	70,0	63,8	77,8
070S	76,6	65,4	64,0	67,6	73,2	73,8	70,2	63,8	78,5
080S	76,6	65,4	63,2	69,1	74,8	76,0	71,0	64,9	80,2
095S	76,6	65,4	64,5	69,2	75,6	81,3	74,2	64,4	84,1
110S	76,6	65,3	66,7	69,7	75,8	81,2	74,2	64,6	84,1
115S	79,9	71,6	71,6	73,5	77,3	83,7	76,3	65,7	86,4
125S	79,9	71,6	70,5	73,8	77,3	78,1	73,4	67,5	82,6
140S	81,7	78,3	76,8	78,9	80,0	85,6	78,4	68,7	88,6
110D	76,6	65,4	65,9	66,7	73,3	72,0	72,1	65,0	78,3
125D	79,9	71,6	70,9	73,9	76,4	76,1	73,5	67,6	81,6
140D	81,7	78,3	76,7	78,8	78,9	78,3	74,7	69,3	84,1
160D	79,6	68,4	66,2	72,1	77,8	79,0	74,0	67,9	83,2
185D	82,9	74,6	73,8	76,3	79,6	84,5	77,7	68,9	87,5
210D	82,9	74,6	74,4	76,5	79,8	84,4	77,7	69,1	87,5

## LOW NOISE UNITS WITH ACOUSTIC JACKET

GAC GAH	Spectrum per octave band (dB)								Global sound power Lw dB(A)
	63 Hz	125 Hz	250 Hz	500 Hz	1000 Hz	2000 Hz	4000 Hz	8000 Hz	
035S	73,5	62,3	60,3	63,9	69,9	65,2	62,7	56,8	72,6
040S	73,5	62,3	60,1	64,3	68,9	65,5	65	57,2	72,6
045S	73,5	62,3	61,6	62,8	67,4	64,4	65	60	71,8
050S	73,5	62,3	61,6	62,5	67,5	65,5	65,6	59,7	72,2
055S	73,5	62,3	61,7	62,3	67,6	66,3	66,2	59,3	72,6
060S	76,9	68,6	67,7	69,9	71,3	70,8	68,1	62,5	76,5
065S	76,6	65,4	63,5	66,6	69,9	69,9	67,2	61,3	75,2
070S	76,6	65,3	63,5	66	70,5	71	67,4	61,2	75,8
080S	76,6	65,3	63	67,1	72	73,1	68,2	62,2	77,4
095S	76,6	65,3	63,7	67,2	72,8	78,3	71,3	61,8	81,1
110S	76,6	65,3	65,2	67,6	73	78,3	71,2	62	81,1
115S	79,9	71,6	71,1	72,7	75	80,8	73,7	64	83,7
125S	79,9	71,6	70,5	72,9	75,1	75,5	71	65,5	80,4
140S	81,7	78,3	76,7	78,6	78,4	82,9	75,9	67,6	86,3
110D	76,6	65,3	64,7	65,3	70,6	69,3	69,2	62,4	75,6
125D	79,9	71,6	70,7	72,9	74,3	73,8	71,1	65,5	79,5
140D	81,7	78,3	76,7	78,5	77,6	76,5	72,9	68	82,8
160D	79,6	68,4	66	70,1	75	76,1	71,2	65,3	80,4
185D	82,9	74,6	73,6	75,6	77,5	81,7	75,2	67,2	85
210D	82,9	74,6	74	75,7	77,6	81,6	75,1	67,3	85

GBC GBH	Spectrum per octave band (dB)								Global sound power Lw dB(A)
	63 Hz	125 Hz	250 Hz	500 Hz	1000 Hz	2000 Hz	4000 Hz	8000 Hz	
040S	73,5	62,4	63,8	66,6	76,6	78,5	73,5	67,6	82,5
060S	76,9	68,6	68,9	70,8	77	79,7	73,8	68	83,3
070S	78,5	69,5	69,3	71	77,4	78,9	74,5	68,6	82,8
080S	79,9	71,6	71	73,3	78,4	79,8	75	69,3	84,1
110S	76,6	65,4	66,3	69,8	77,8	80,4	74,6	68,6	84
120S	79,9	71,6	72	73,7	78,9	83,2	76,6	69,2	86,3
125D	79,9	71,6	71,3	73,8	78,8	79,9	75,9	70	84,4
140D	81,7	78,3	76,8	78,9	80,7	81,3	76,8	71,3	86,1
160D	79,6	68,4	67,4	72,3	79,6	81,2	76,2	70,2	85,2
185D	82,9	74,6	73,9	76,3	80,6	83,7	77,9	70,9	87,3
210D	82,9	74,6	74,3	76,5	80,7	84	77,9	71	87,5

## LOW NOISE UNITS WITH ACOUSTIC JACKET

GBC GBH	Spectrum per octave band (dB)								Global sound power Lw dB(A)
	63 Hz	125 Hz	250 Hz	500 Hz	1000 Hz	2000 Hz	4000 Hz	8000 Hz	
040S	73,5	62,4	62,2	64,5	73,6	75,6	70,6	64,7	79,5
060S	76,9	68,6	68,2	69,9	74,4	76,8	71,1	65,5	80,6
070S	78,5	69,5	68,7	70,3	74,9	76,1	71,8	66	80,6
080S	79,9	71,6	70,7	72,6	76	77,1	72,5	66,9	81,6
110S	76,6	65,4	64,9	67,7	74,9	77,4	71,7	65,8	81,1
120S	79,9	71,6	71,3	72,8	76,4	80,3	73,9	66,8	83,7
125D	79,9	71,6	70,9	72,9	76,4	77,2	73,3	67,5	81,9
140D	81,7	78,3	76,7	78,6	78,9	78,9	74,6	69,5	84,3
160D	79,6	68,4	66,7	70,2	76,7	78,2	73,3	67,4	82,3
185D	82,9	74,6	73,7	75,6	78,3	81	75,3	68,8	84,8
210D	82,9	74,6	73,9	75,7	78,4	81,3	75,3	68,8	85

## BASIC UNITS + ADVANCED UNITS: COOLING ONLY

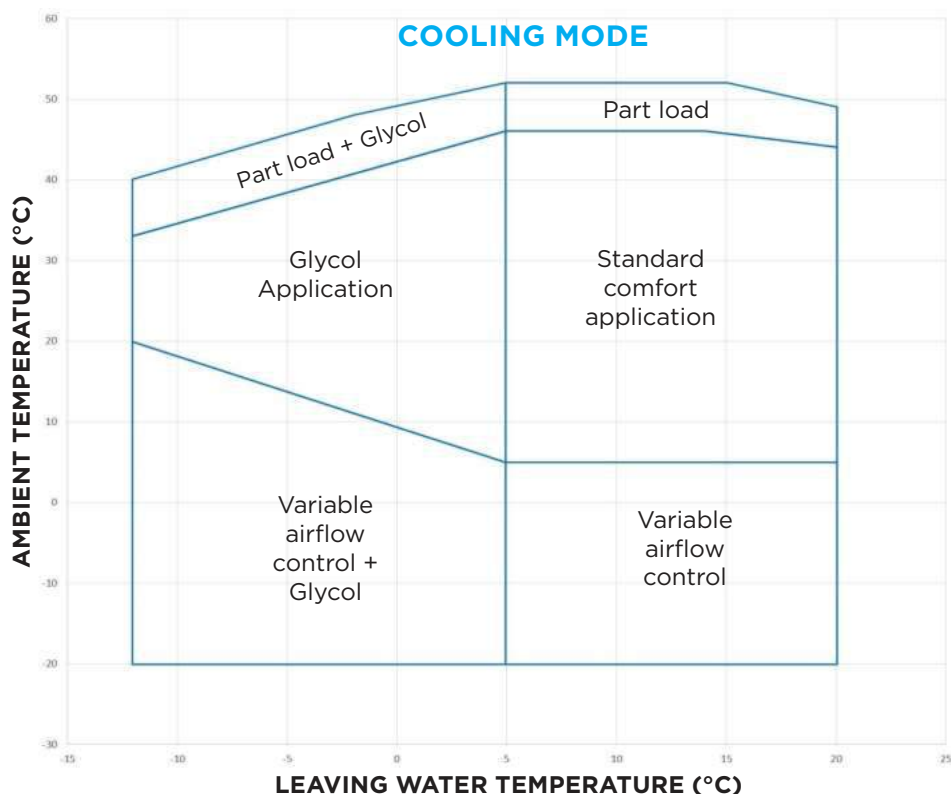

# OPERATING LIMITS



## ADVANCED UNITS - SINGLE CIRCUIT: HEAT PUMP

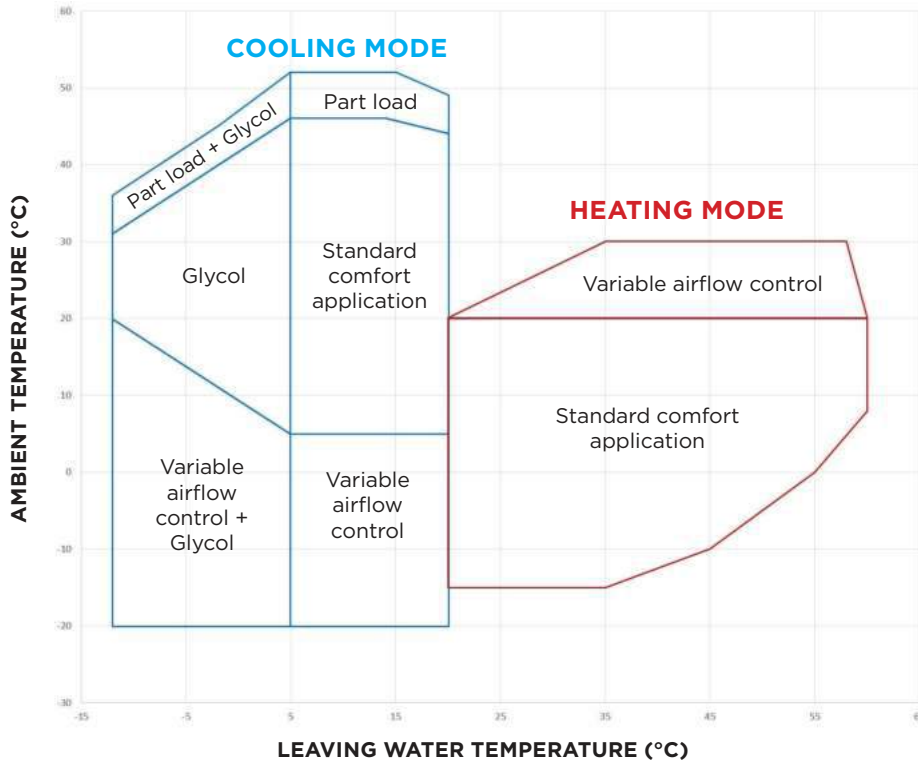

## BASIC UNITS + ADVANCED UNITS - DUAL CIRCUIT: HEAT PUMP

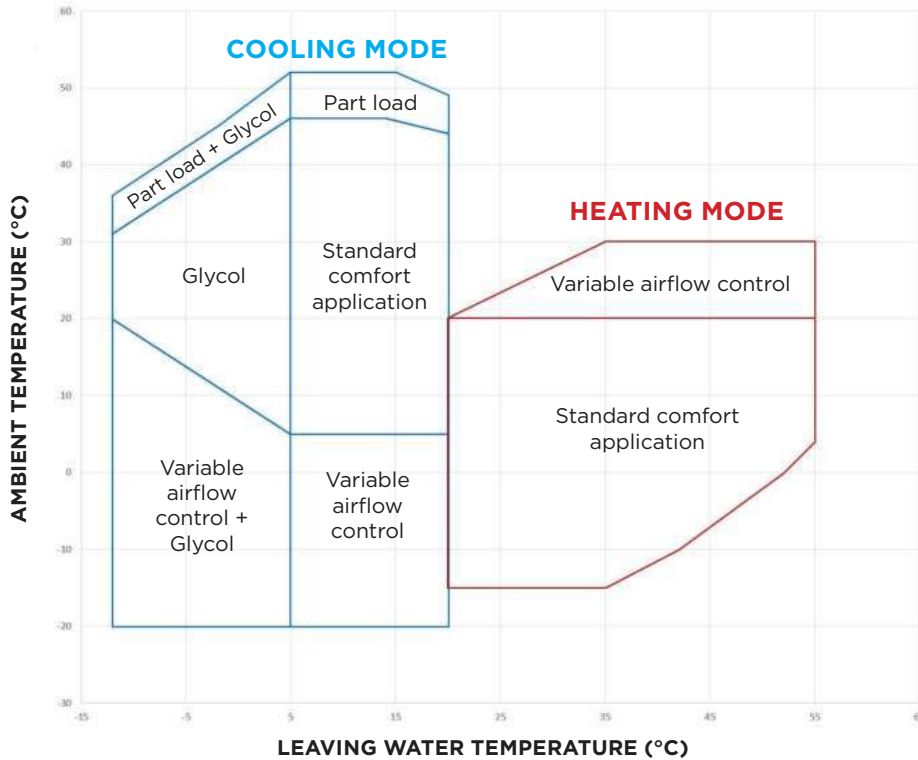

### UNITS WITH LOW WATER TEMPERATURE KIT (OPTION)

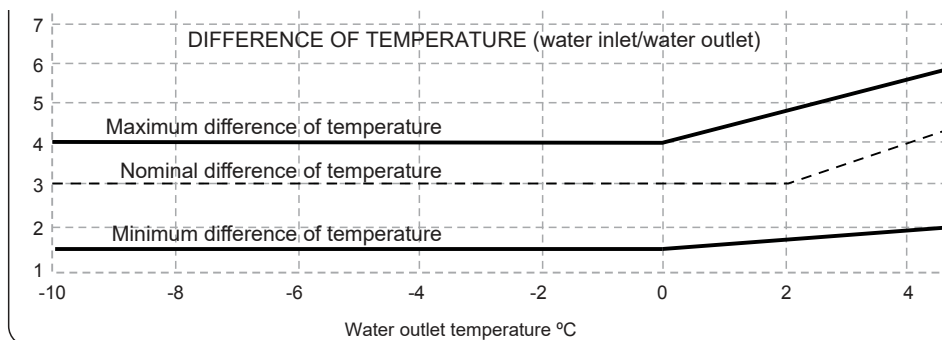

## eCOMFORT R32 - GAC

GAC		035S	040S	045S	050S	055S	060S	065S	070S	080S	095S
Maximun power	kW	17,38	18,82	20,64	22,33	24,02	28,83	28,33	30,93	36,98	41,53
Maximun current	A	28,11	31,01	35,35	38,10	40,85	47,53	46,98	52,59	62,88	69,99
<b>LRC</b>											
Starting current	A	115,98	108,43	146,60	157,60	160,35	164,35	163,80	208,80	219,09	273,34
Starting current with SoftStarter	A	75,58	71,63	95,40	102,00	104,75	107,95	107,40	134,40	144,69	177,34
<b>SFAC FAN</b>											
Additional power	kW	0,05	0,05	0,05	0,05	1,10	-0,26	-0,48	0,10	0,10	0,10
Additional current	A	0,82	0,82	0,82	0,82	2,50	0,50	-0,40	1,64	1,64	1,64
<b>HIPF FAN</b>											
Additional power	kW	1,36	1,36	1,36	1,36	1,36	0,83	2,72	2,72	2,72	2,72
Additional current	A	2,00	2,00	2,00	2,00	2,00	1,20	4,00	4,00	4,00	4,00
<b>LOW PRESSURE WATER PUMP</b>											
Additional power	kW	1,35	1,35	1,35	1,35	1,35	1,35	1,35	1,35	1,35	1,95
Additional current	A	2,45	2,45	2,45	2,45	2,45	2,45	2,45	2,45	2,45	3,43
<b>HIGH PRESSURE WATER PUMP</b>											
Additional power	kW	1,73	1,73	1,73	1,73	1,73	1,73	1,73	1,73	1,73	3,28
Additional current	A	3,15	3,15	3,15	3,15	3,15	3,15	3,15	3,15	3,15	6,24
<b>ANTIFREEZE ELECTRICAL HEAT</b>											
Additional power	kW	2,25	2,25	2,25	6,00	6,00	6,00	6,00	6,00	6,00	6,00
Additional current	A	3,25	3,25	3,25	8,66	8,66	8,66	8,66	8,66	8,66	8,66

GAC		110S	115S	125S	140S	110D	125D	140D	160D	185D	210D
Maximun power	kW	47,13	54,30	57,35	72,37	48,00	57,62	64,47	73,88	88,30	99,50
Maximun current	A	79,15	90,01	96,92	119,95	81,60	94,96	108,58	125,56	147,48	165,80
<b>LRC</b>											
Starting current	A	320,34	331,20	253,13	323,30	201,10	211,78	264,79	281,77	350,83	406,99
Starting current with SoftStarter	A	205,54	216,40	178,73	227,30	145,50	155,38	190,39	207,37	254,83	292,19
<b>SFAC FAN</b>											
Additional power	kW	2,20	-0,52	-0,52	-2,17	0,10	-0,52	-2,17	0,20	-5,24	-1,04
Additional current	A	5,00	1,00	1,00	-1,40	1,64	1,00	-1,40	3,28	-4,72	2,00
<b>HIPF FAN</b>											
Additional power	kW	2,72	1,65	1,65	0,00	2,72	1,65	0,00	5,44	3,30	3,30
Additional current	A	4,00	2,40	2,40	0,00	4,00	2,40	0,00	8,00	4,80	4,80
<b>LOW PRESSURE WATER PUMP</b>											
Additional power	kW	1,95	1,95	1,95	1,95	1,95	1,95	1,95	3,28	3,28	3,28
Additional current	A	3,43	3,43	3,43	3,43	3,43	3,43	3,43	6,24	6,24	6,24
<b>HIGH PRESSURE WATER PUMP</b>											
Additional power	kW	3,28	3,28	3,28	3,28	3,28	3,28	3,28	4,50	4,50	4,50
Additional current	A	6,24	6,24	6,24	6,24	6,24	6,24	6,24	7,62	7,62	7,62
<b>ANTIFREEZE ELECTRICAL HEAT</b>											
Additional power	kW	6,00	6,00	6,00	6,00	9,00	9,00	9,00	12,00	12,00	12,00
Additional current	A	8,66	8,66	8,66	8,66	12,99	12,99	12,99	17,32	17,32	17,32

SFAC	Variable airflow control with standard AC fans
HIPP	Variable airflow control with high pressure EC fans

**eCOMFORT R32 - GAH**

<b>GAH</b>		<b>035S</b>	<b>040S</b>	<b>045S</b>	<b>050S</b>	<b>055S</b>	<b>060S</b>	<b>065S</b>	<b>070S</b>	<b>080S</b>	<b>095S</b>
Maximum power	kW	17,38	18,82	20,64	22,33	25,38	28,83	28,33	30,93	36,98	41,53
Maximum current	A	28,11	31,01	35,35	38,10	42,85	47,53	46,98	52,59	62,88	69,99
<b>LRC</b>											
Starting current	A	115,98	108,43	146,60	157,60	162,35	164,35	163,80	208,80	219,09	273,34
Starting current with SoftStarter	A	75,58	71,63	95,40	102,00	106,75	107,95	107,40	134,40	144,69	177,34
<b>SFAC FAN</b>											
Additional power	kW	0,05	0,05	0,05	0,05	-0,26	-0,26	-0,48	0,10	0,10	0,10
Additional current	A	0,82	0,82	0,82	0,82	0,50	0,50	-0,40	1,64	1,64	1,64
<b>HIPF FAN</b>											
Additional power	kW	1,36	1,36	1,36	1,36	0,83	0,83	2,72	2,72	2,72	2,72
Additional current	A	2,00	2,00	2,00	2,00	1,20	1,20	4,00	4,00	4,00	4,00
<b>LOW PRESSURE WATER PUMP</b>											
Additional power	kW	1,35	1,35	1,35	1,35	1,35	1,35	1,35	1,35	1,35	1,95
Additional current	A	2,45	2,45	2,45	2,45	2,45	2,45	2,45	2,45	2,45	3,43
<b>HIGH PRESSURE WATER PUMP</b>											
Additional power	kW	1,73	1,73	1,73	1,73	1,73	1,73	1,73	1,73	1,73	3,28
Additional current	A	3,15	3,15	3,15	3,15	3,15	3,15	3,15	3,15	3,15	6,24
<b>ANTIFREEZE ELECTRICAL HEAT</b>											
Additional power	kW	2,25	2,25	2,25	6,00	6,00	6,00	6,00	6,00	6,00	9,00
Additional current	A	3,25	3,25	3,25	8,66	8,66	8,66	8,66	8,66	8,66	12,99
<b>STANDARD ELECTRICAL HEATER</b>											
Additional power	kW	9,00	9,00	9,00	18,00	18,00	18,00	18,00	18,00	18,00	27,00
Additional current	A	12,99	12,99	12,99	25,98	25,98	25,98	25,98	25,98	25,98	38,97
<b>HIGH ELECTRICAL HEATER</b>											
Additional power	kW	12,00	12,00	12,00	24,00	24,00	24,00	24,00	24,00	24,00	36,00
Additional current	A	17,32	17,32	17,32	34,64	34,64	34,64	34,64	34,64	34,64	51,96

<b>GAH</b>		<b>110S</b>	<b>115S</b>	<b>125S</b>	<b>140S</b>	<b>110D</b>	<b>125D</b>	<b>140D</b>	<b>160D</b>	<b>185D</b>	<b>210D</b>
Maximum power	kW	47,13	54,30	57,35	72,37	48,00	57,62	64,47	73,88	88,30	99,50
Maximum current	A	79,15	90,01	96,92	119,95	81,60	94,96	108,58	125,56	147,48	165,80
<b>LRC</b>											
Starting current	A	320,34	331,20	253,13	323,30	201,10	211,78	264,79	281,77	350,83	406,99
Starting current with SoftStarter	A	205,54	216,40	178,73	227,30	145,50	155,38	190,39	207,37	254,83	292,19
<b>SFAC FAN</b>											
Additional power	kW	2,20	-0,52	-0,52	-2,17	0,10	-0,52	-2,17	0,20	-5,24	-1,04
Additional current	A	5,00	1,00	1,00	-1,40	1,64	1,00	-1,40	3,28	-4,72	2,00
<b>HIPF FAN</b>											
Additional power	kW	2,72	1,65	1,65	0,00	2,72	1,65	0,00	5,44	3,30	3,30
Additional current	A	4,00	2,40	2,40	0,00	4,00	2,40	0,00	8,00	4,80	4,80
<b>LOW PRESSURE WATER PUMP</b>											
Additional power	kW	1,95	1,95	1,95	1,95	1,95	1,95	1,95	3,28	3,28	3,28
Additional current	A	3,43	3,43	3,43	3,43	3,43	3,43	3,43	6,24	6,24	6,24
<b>HIGH PRESSURE WATER PUMP</b>											
Additional power	kW	3,28	3,28	3,28	3,28	3,28	3,28	3,28	4,50	4,50	4,50
Additional current	A	6,24	6,24	6,24	6,24	6,24	6,24	6,24	7,62	7,62	7,62
<b>ANTIFREEZE ELECTRICAL HEAT</b>											
Additional power	kW	9,00	9,00	9,00	9,00	9,00	9,00	9,00	12,00	12,00	12,00
Additional current	A	12,99	12,99	12,99	12,99	12,99	12,99	12,99	17,32	17,32	17,32
<b>STANDARD ELECTRICAL HEATER</b>											
Additional power	kW	27,00	27,00	27,00	27,00	27,00	27,00	27,00	36,00	36,00	36,00
Additional current	A	38,97	38,97	38,97	38,97	38,97	38,97	38,97	51,96	51,96	51,96
<b>HIGH ELECTRICAL HEATER</b>											
Additional power	kW	36,00	36,00	36,00	36,00	36,00	36,00	36,00	48,00	48,00	48,00
Additional current	A	51,96	51,96	51,96	51,96	51,96	51,96	51,96	69,28	69,28	69,28

<b>SFAC</b>	Variable airflow control with standard AC fans
<b>HIPP</b>	Variable airflow control with high pressure EC fans

## eCOMFORT R32 - GBC

GBC			040S	060S	070S	080S	110S	120S
Maximun power	kW		16,37	25,28	28,73	37,50	42,43	55,20
Maximun current	A		26,13	40,99	47,08	61,37	70,48	89,85
<b>LRC</b>								
Starting current	A		26,13	40,99	166,58	217,58	226,69	331,69
Starting current with SoftStarter	A		26,13	40,99	110,98	143,18	152,29	225,33
<b>HIPF FAN</b>								
Additional power	kW		1,36	0,83	2,72	1,65	2,72	1,65
Additional current	A		2,00	1,20	4,00	2,40	4,00	2,40
<b>LOW PRESSURE WATER PUMP</b>								
Additional power	kW		1,35	1,35	1,35	1,35	1,95	1,95
Additional current	A		2,45	2,45	2,45	2,45	3,43	3,43
<b>HIGH PRESSURE WATER PUMP</b>								
Additional power	kW		1,73	1,73	1,73	1,73	3,28	3,28
Additional current	A		3,15	3,15	3,15	3,15	6,24	6,24
<b>ANTIFREEZE ELECTRICAL HEATER</b>								
Additional power	kW		2,25	6,00	6,00	6,00	6,00	6,00
Additional current	A		3,25	8,66	8,66	8,66	8,66	8,66

GBC			125D	140D	160D	185D	210D
Maximun power	kW		58,02	68,32	71,68	81,65	94,80
Maximun current	A		95,06	113,36	120,05	134,29	156,48
<b>LRC</b>							
Starting current	A		211,88	269,57	276,26	338,46	398,32
Starting current with SoftStarter	A		155,48	195,17	201,86	241,78	291,96
<b>HIPF FAN</b>							
Additional power	kW		1,65	0,00	5,44	3,30	3,30
Additional current	A		2,40	0,00	8,00	4,80	4,80
<b>LOW PRESSURE WATER PUMP</b>							
Additional power	kW		1,95	1,95	3,28	3,28	3,28
Additional current	A		3,43	3,43	6,24	6,24	6,24
<b>HIGH PRESSURE WATER PUMP</b>							
Additional power	kW		3,28	3,28	4,50	4,50	4,50
Additional current	A		6,24	6,24	7,62	7,62	7,62
<b>ANTIFREEZE ELECTRICAL HEATER</b>							
Additional power	kW		9,00	9,00	12,00	12,00	12,00
Additional current	A		12,99	12,99	17,32	17,32	17,32

HIPP	Variable airflow control with high pressure EC fans
------	---

## eCOMFORT R32 - GBH

GBH		040S	060S	070S	080S	110S	120S
Maximun power	kW	16,37	25,28	28,73	37,50	42,43	55,20
Maximun current	A	26,13	40,99	47,08	61,37	70,48	89,85
<b>LRC</b>							
Starting current	A	26,13	40,99	166,58	217,58	226,69	331,69
Starting current with SoftStarter	A	26,13	40,99	110,98	143,18	152,29	225,33
<b>HIPF FAN</b>							
Additional power	kW	1,36	0,83	2,72	1,65	2,72	1,65
Additional current	A	2,00	1,20	4,00	2,40	4,00	2,40
<b>LOW PRESSURE WATER PUMP</b>							
Additional power	kW	1,35	1,35	1,35	1,35	1,95	1,95
Additional current	A	2,45	2,45	2,45	2,45	3,43	3,43
<b>HIGH PRESSURE WATER PUMP</b>							
Additional power	kW	1,73	1,73	1,73	1,73	3,28	3,28
Additional current	A	3,15	3,15	3,15	3,15	6,24	6,24
<b>ANTIFREEZE ELECTRICAL HEATER</b>							
Additional power	kW	2,25	6,00	6,00	6,00	9,00	9,00
Additional current	A	3,25	8,66	8,66	8,66	12,99	12,99
<b>STANDARD ELECTRICAL HEATER</b>							
Additional power	kW	9,00	18,00	18,00	18,00	27,00	27,00
Additional current	A	12,99	25,98	25,98	25,98	38,97	38,97
<b>HIGH ELECTRICAL HEATER</b>							
Additional power	kW	12,00	24,00	24,00	24,00	36,00	36,00
Additional current	A	17,32	34,64	34,64	34,64	51,96	51,96

GBH		125D	140D	160D	185D	210D
Maximun power	kW	58,02	68,32	71,68	81,65	94,80
Maximun current	A	95,06	113,36	120,05	134,29	156,48
<b>LRC</b>						
Starting current	A	211,88	269,57	276,26	338,46	398,32
Starting current with SoftStarter	A	155,48	195,17	201,86	241,78	291,96
<b>HIPF FAN</b>						
Additional power	kW	1,65	0,00	5,44	3,30	3,30
Additional current	A	2,40	0,00	8,00	4,80	4,80
<b>LOW PRESSURE WATER PUMP</b>						
Additional power	kW	1,95	1,95	3,28	3,28	3,28
Additional current	A	3,43	3,43	6,24	6,24	6,24
<b>HIGH PRESSURE WATER PUMP</b>						
Additional power	kW	3,28	3,28	4,50	4,50	4,50
Additional current	A	6,24	6,24	7,62	7,62	7,62
<b>ANTIFREEZE ELECTRICAL HEATER</b>						
Additional power	kW	9,00	9,00	12,00	12,00	12,00
Additional current	A	12,99	12,99	17,32	17,32	17,32
<b>STANDARD ELECTRICAL HEATER</b>						
Additional power	kW	27,00	27,00	36,00	36,00	36,00
Additional current	A	38,97	38,97	51,96	51,96	51,96
<b>HIGH ELECTRICAL HEATER</b>						
Additional power	kW	36,00	36,00	48,00	48,00	48,00
Additional current	A	51,96	51,96	69,28	69,28	69,28

HIPP Variable airflow control with high pressure EC fans

**GAC/H 035S**

**STANDARD VERSION (EC FAN) AND HIGH PRESSURE EC FAN (HIPF)**

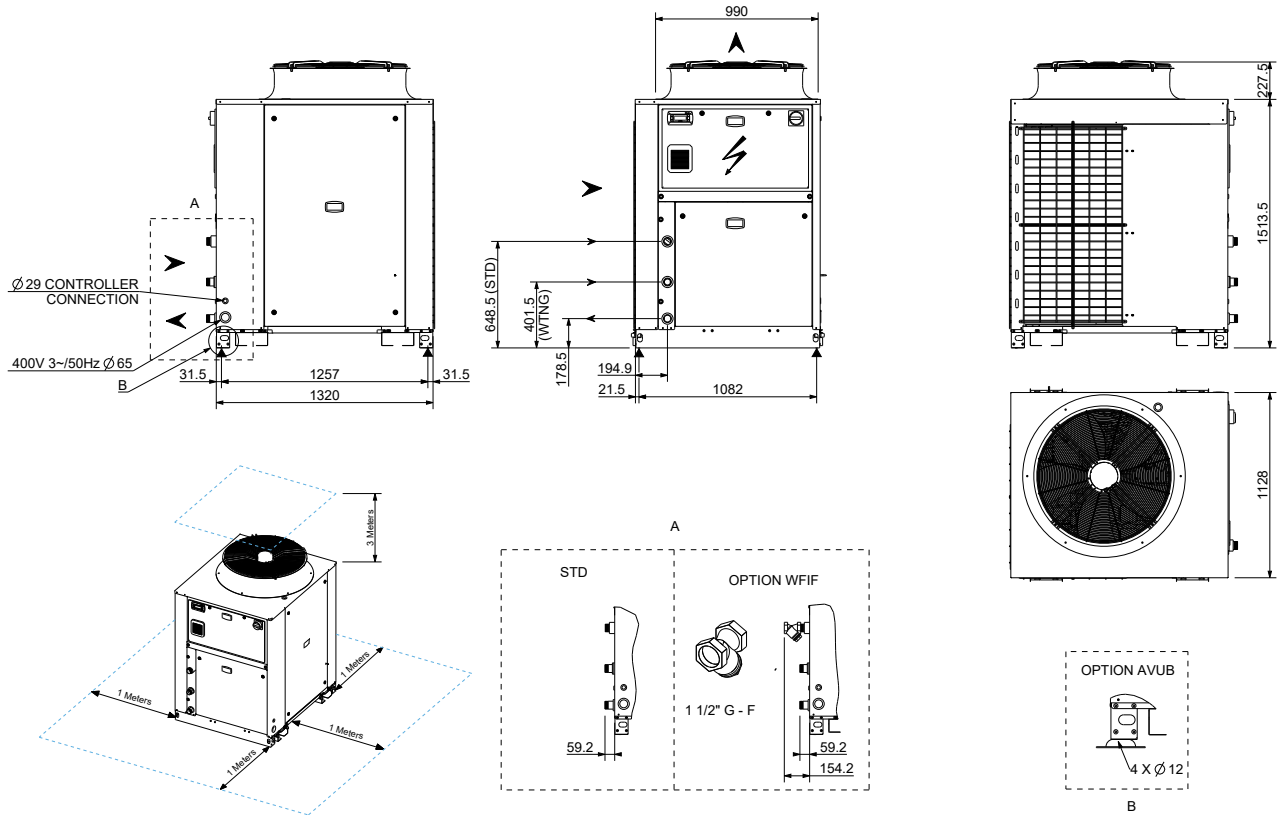

All dimensions in millimeters

**UNIT WITH AC FAN (SFAC)**

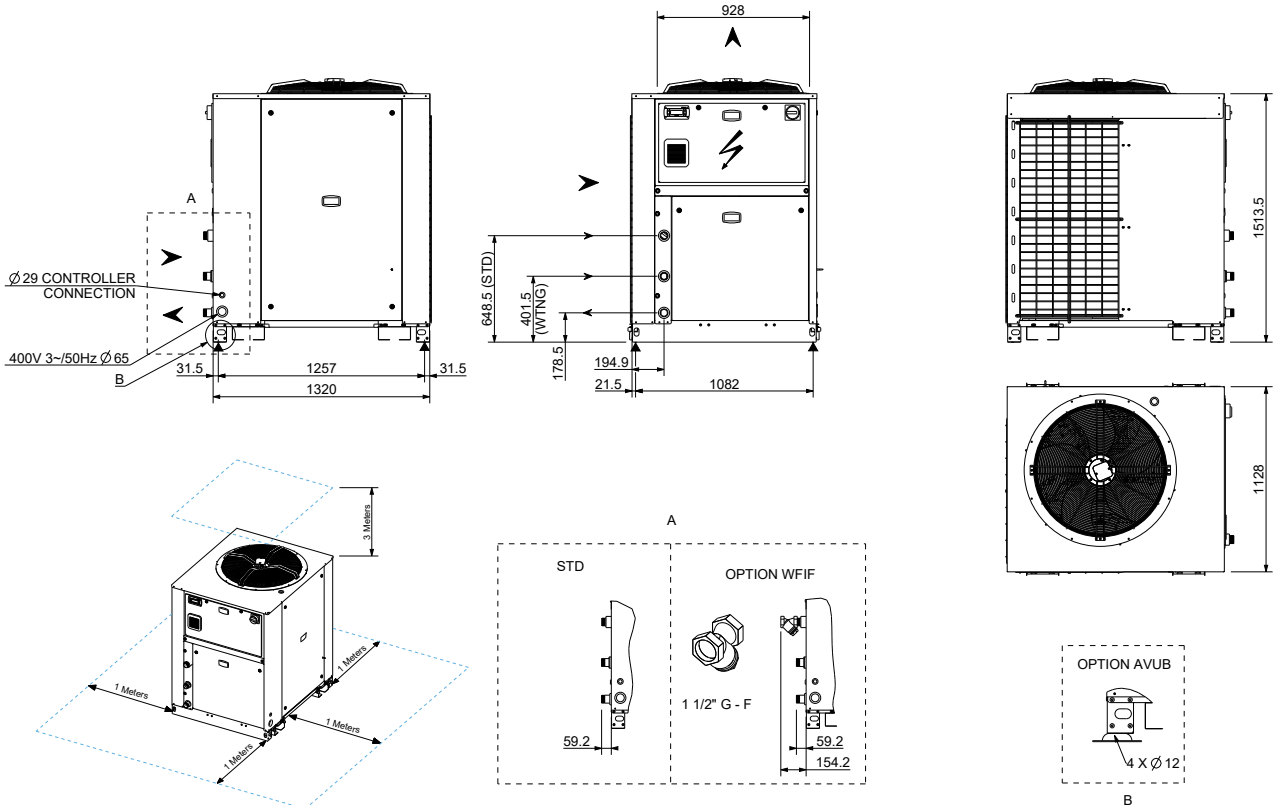

All dimensions in millimeters

**GAC/H 040S - 045S**

**STANDARD VERSION (EC FAN) AND HIGH PRESSURE EC FAN (HIPF)**

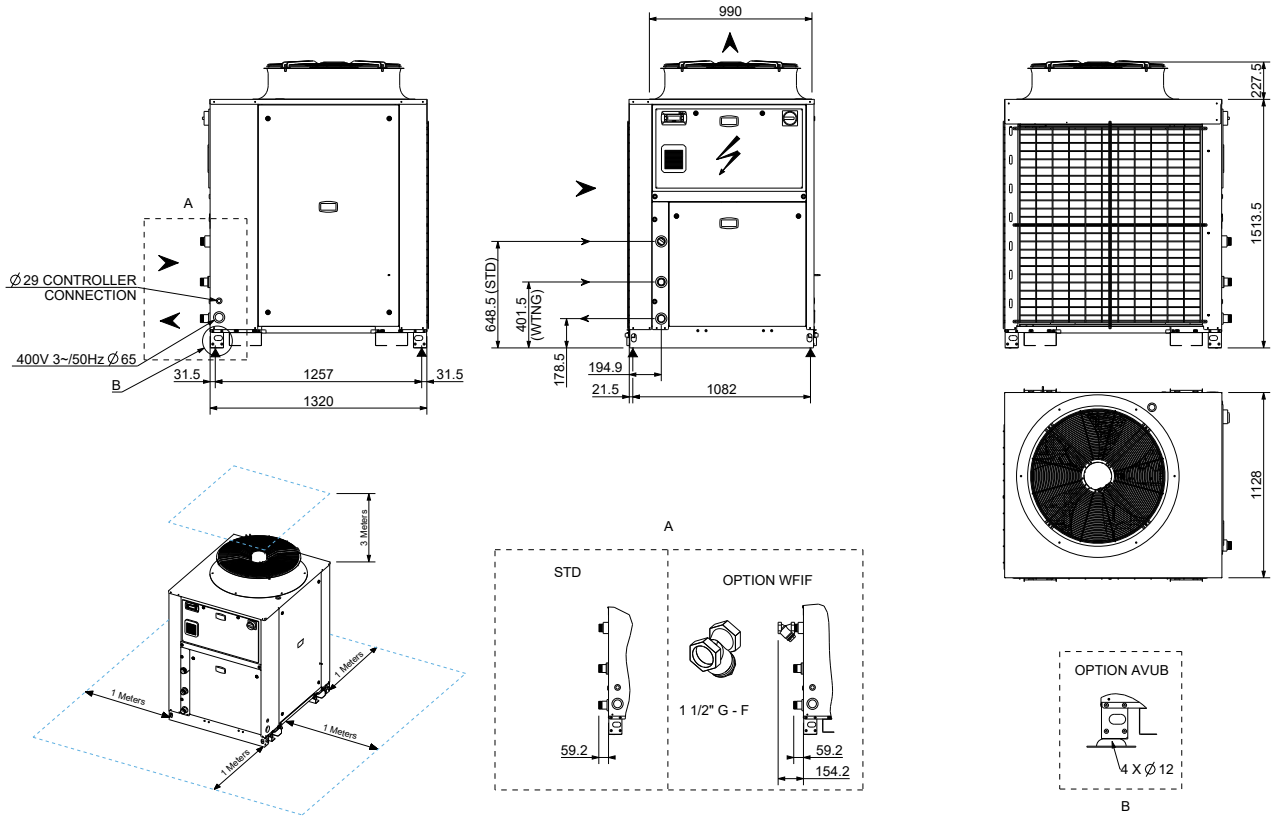

All dimensions in millimeters

**UNIT WITH AC FAN (SFAC)**

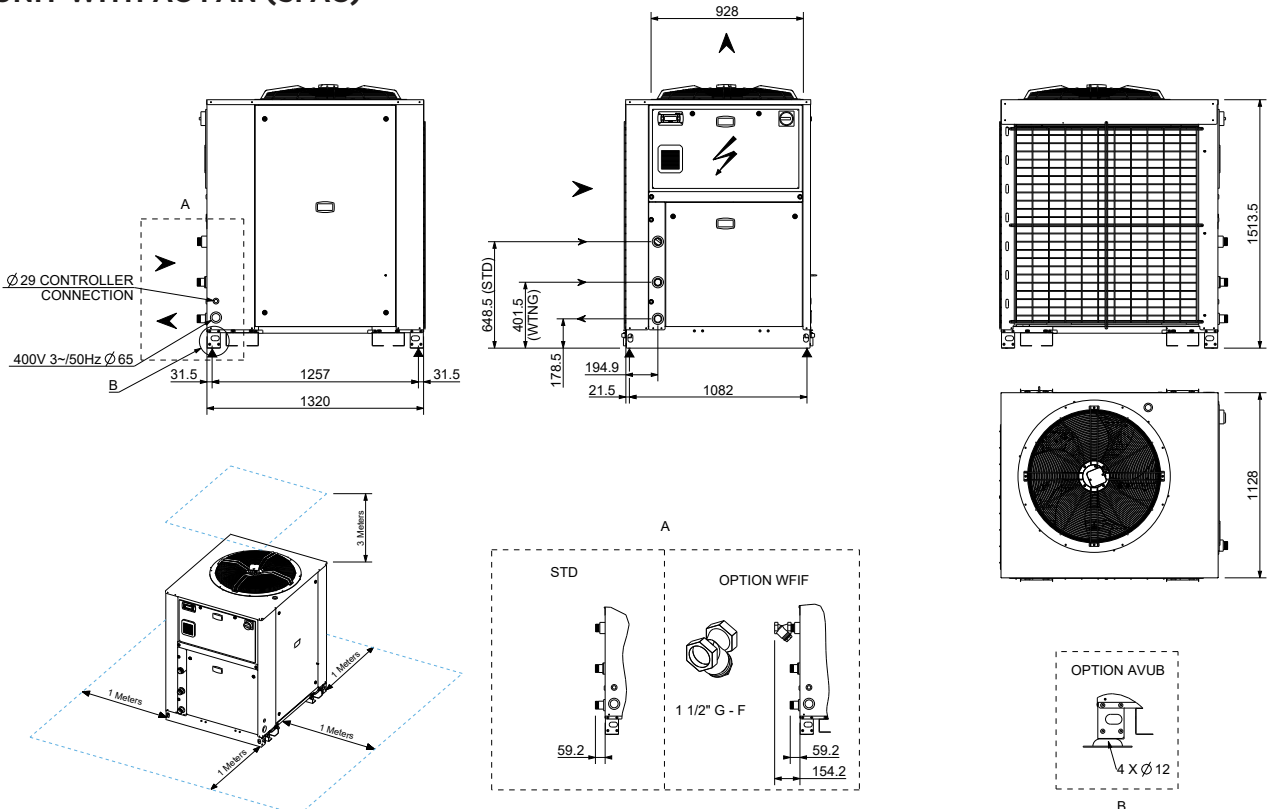

All dimensions in millimeters

**GAC/H 050S-055S-060S**

**STANDARD VERSION (EC FAN) AND HIGH PRESSURE EC FAN (HIPF)**

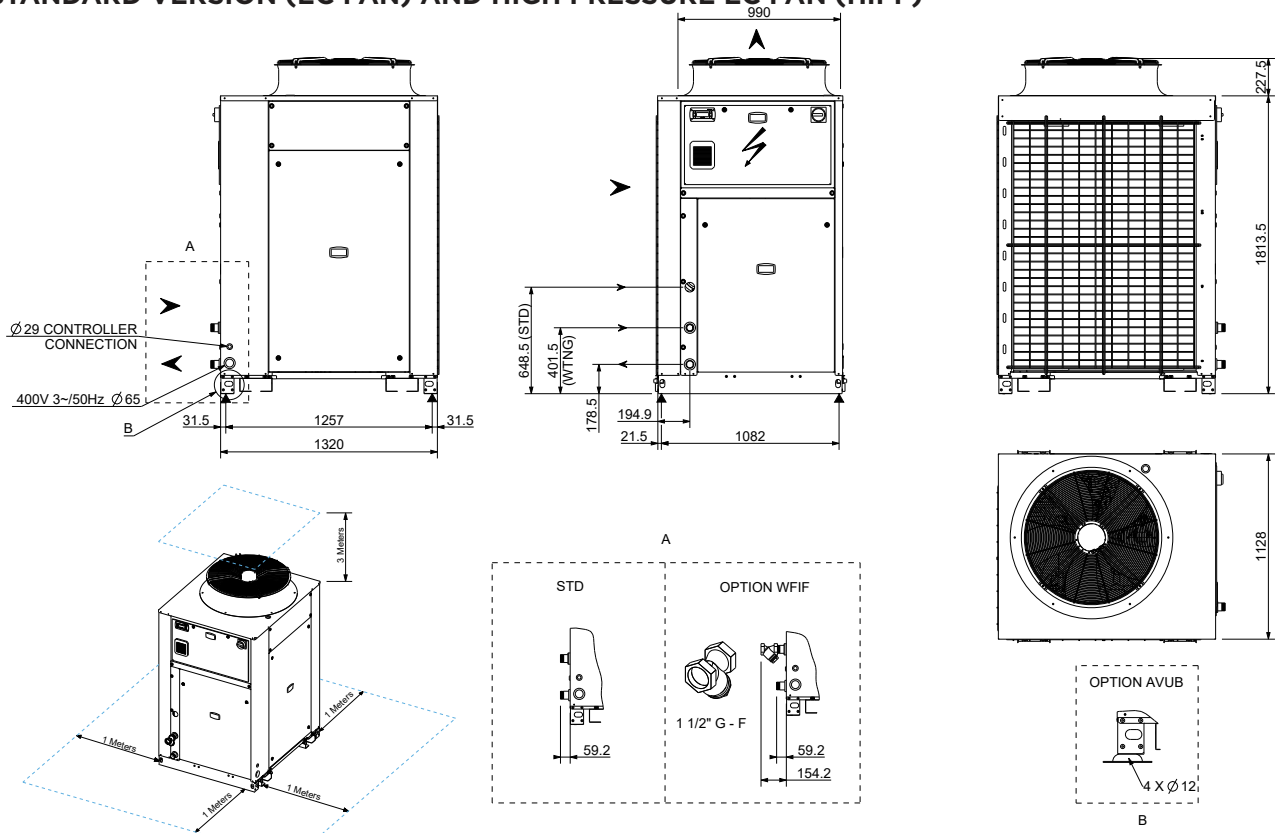

All dimensions in millimeters

**UNIT WITH AC FAN (SFAC)**

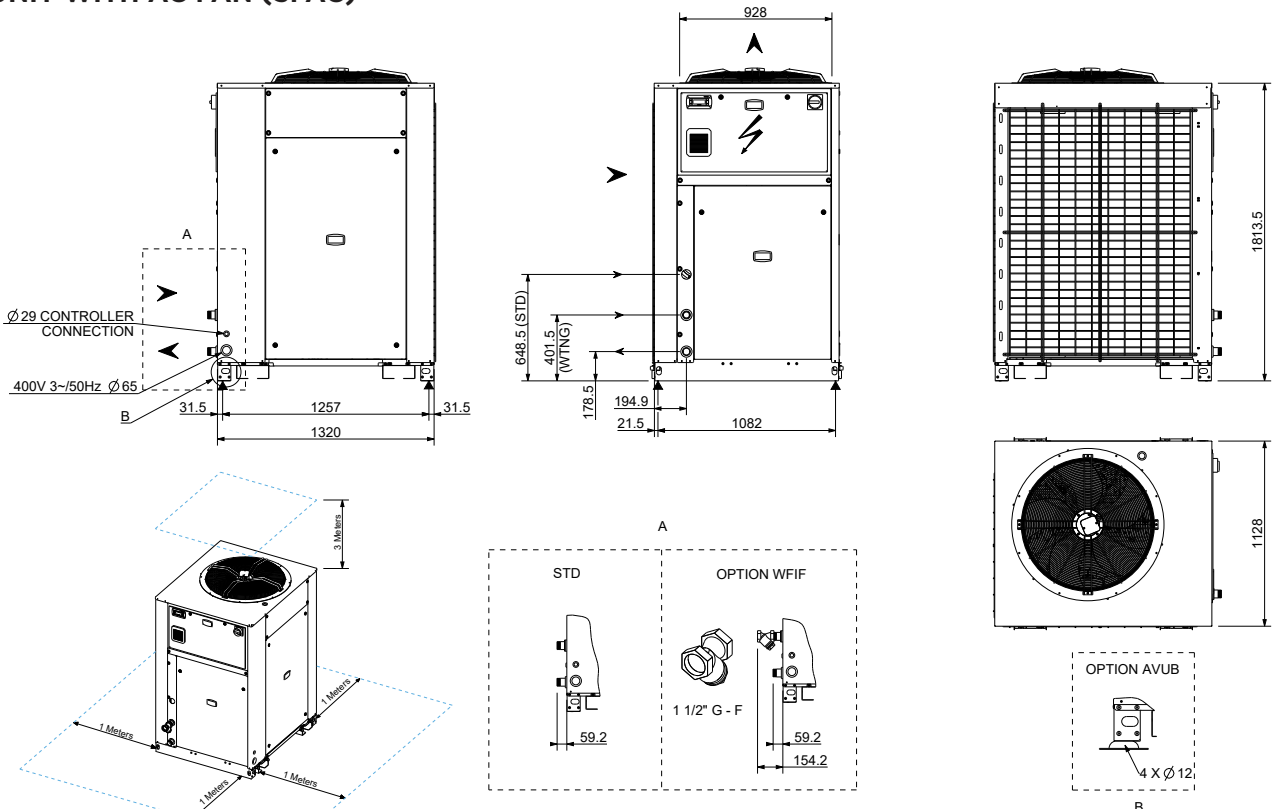

All dimensions in millimeters

GAC/H 065S - 070S

STANDARD VERSION (EC FAN) AND HIGH PRESSURE EC FAN (HIPF)

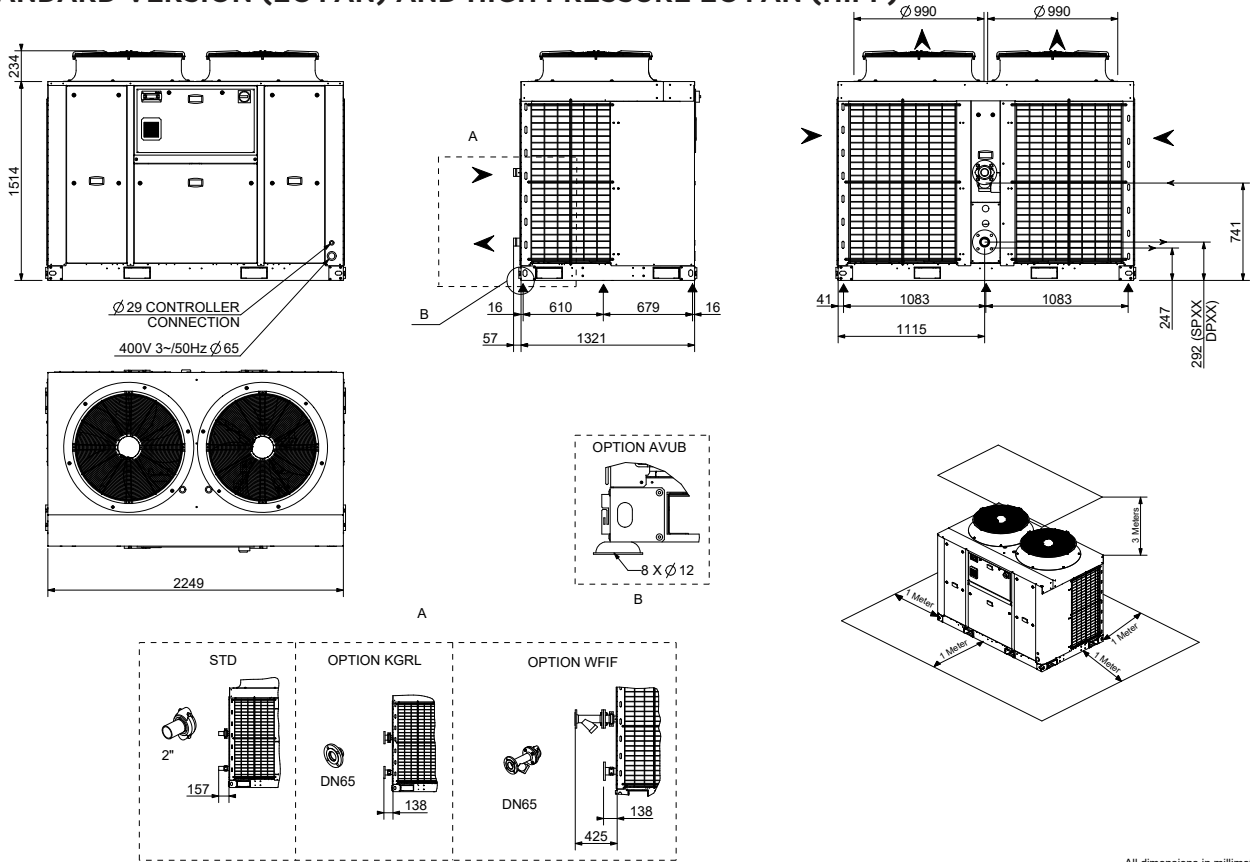

All dimensions in millimeters

UNIT WITH AC FAN (SFAC)

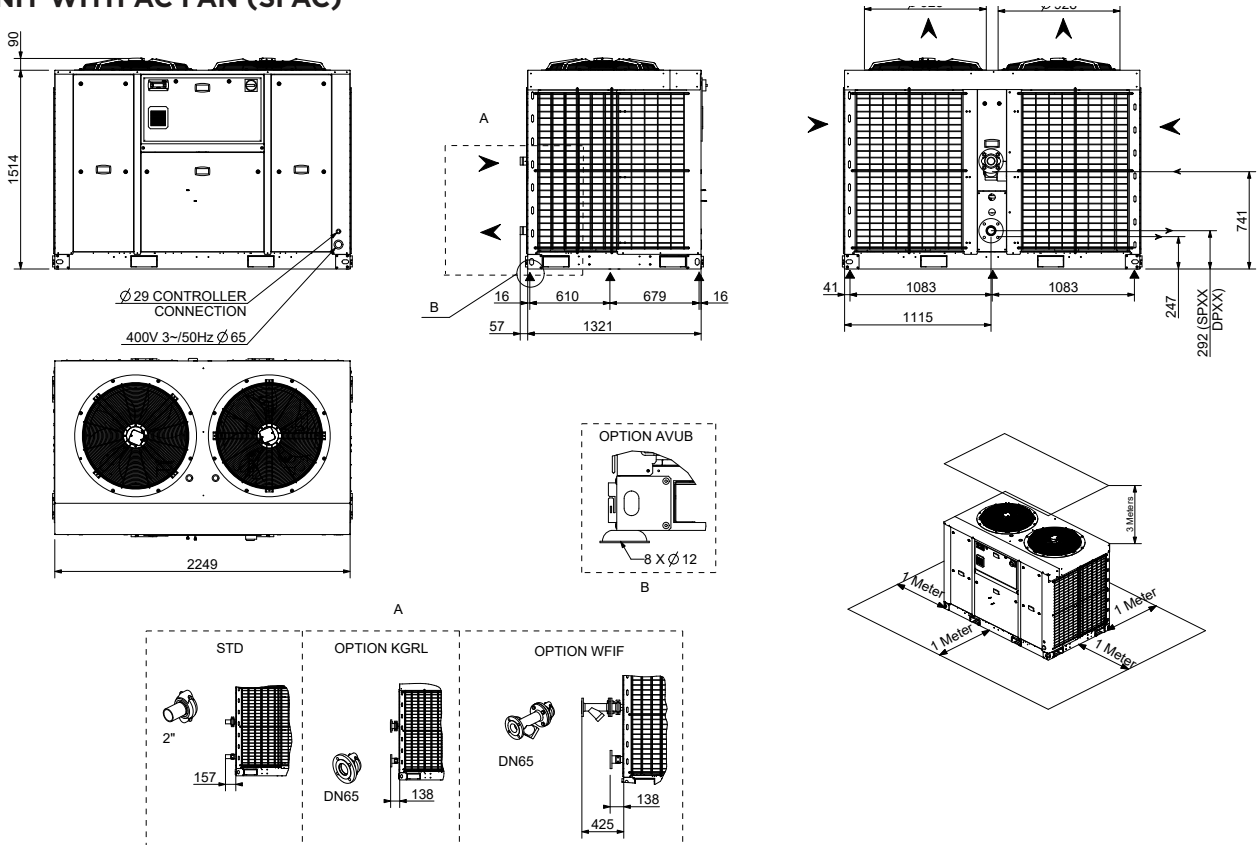

All dimensions in millimeters

**GAC/H 080S**

**STANDARD VERSION (EC FAN) AND HIGH PRESSURE EC FAN (HIPF)**

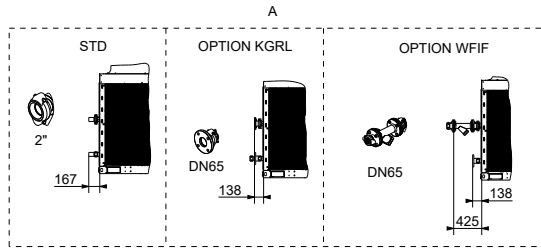
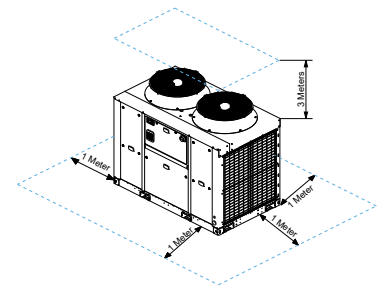
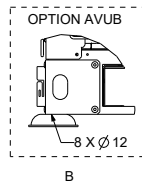
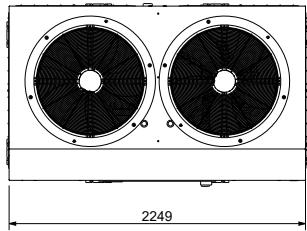
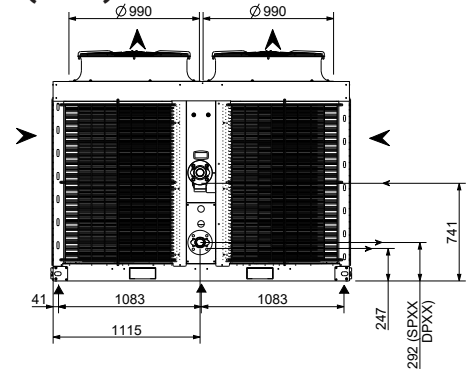
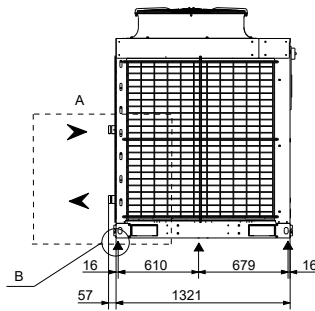
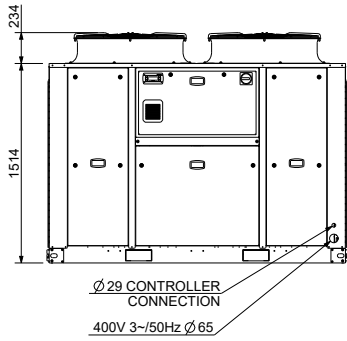

All dimensions in millimeters

**UNIT WITH AC FAN (SFAC)**

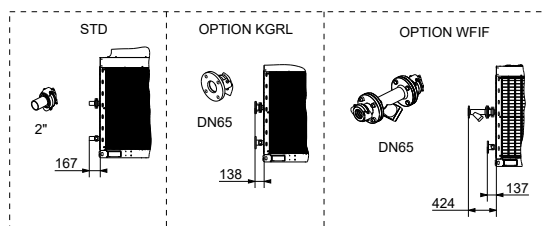
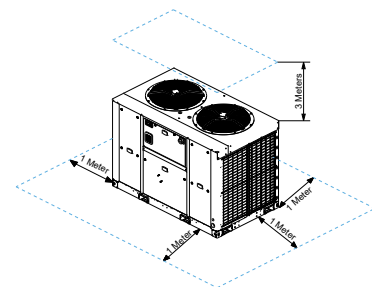
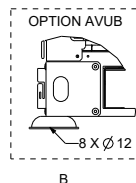
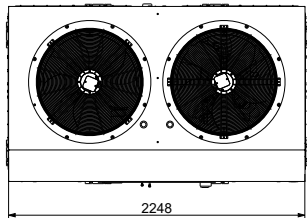
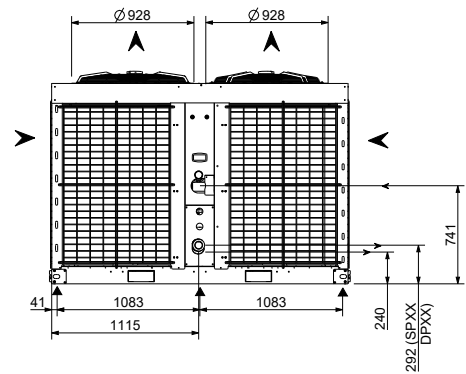
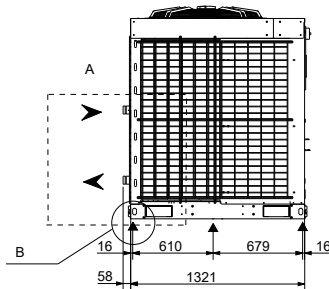
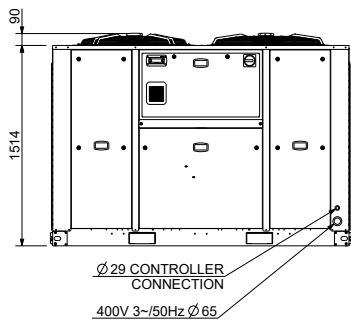

All dimensions in millimeters

**GAC/H 095S - 110S - 115S**

**STANDARD VERSION (EC FAN) AND HIGH PRESSURE EC FAN (HIPF)**

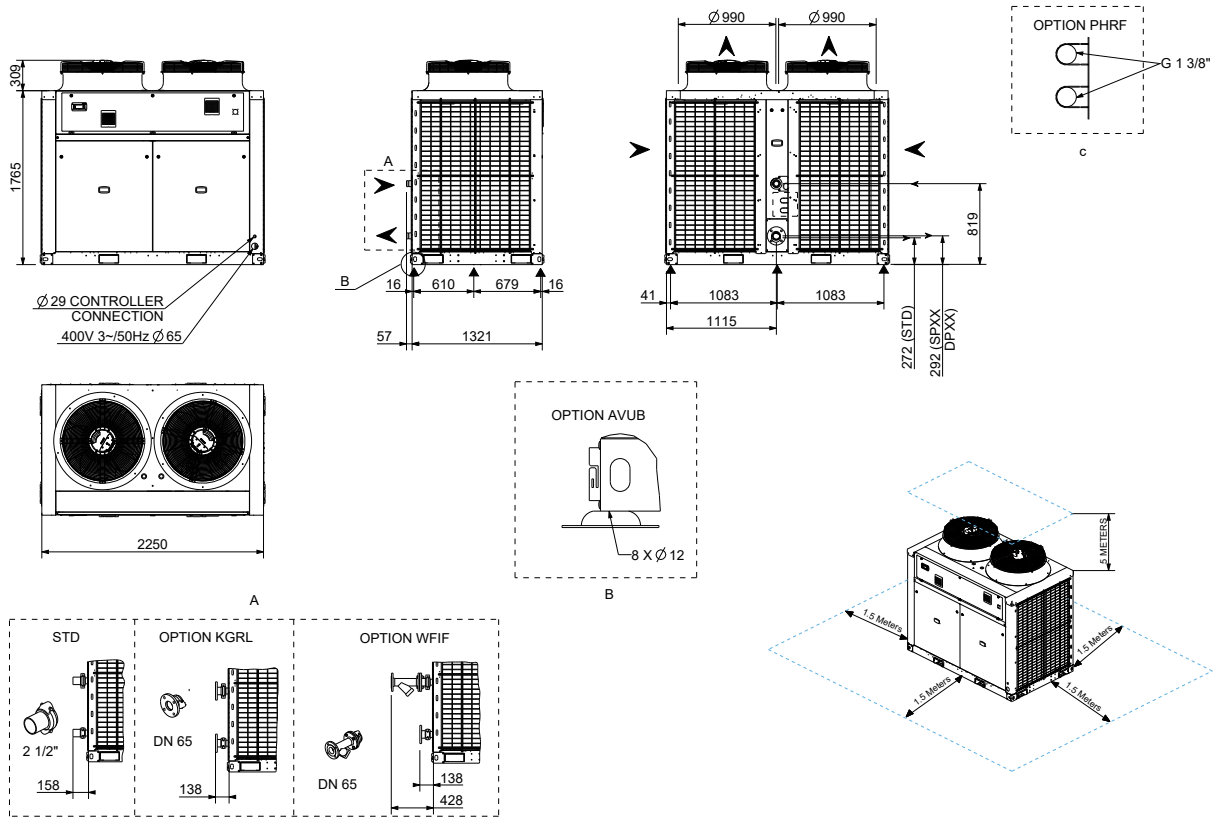

All dimensions in millimeters

**UNIT WITH AC FAN (SFAC)**

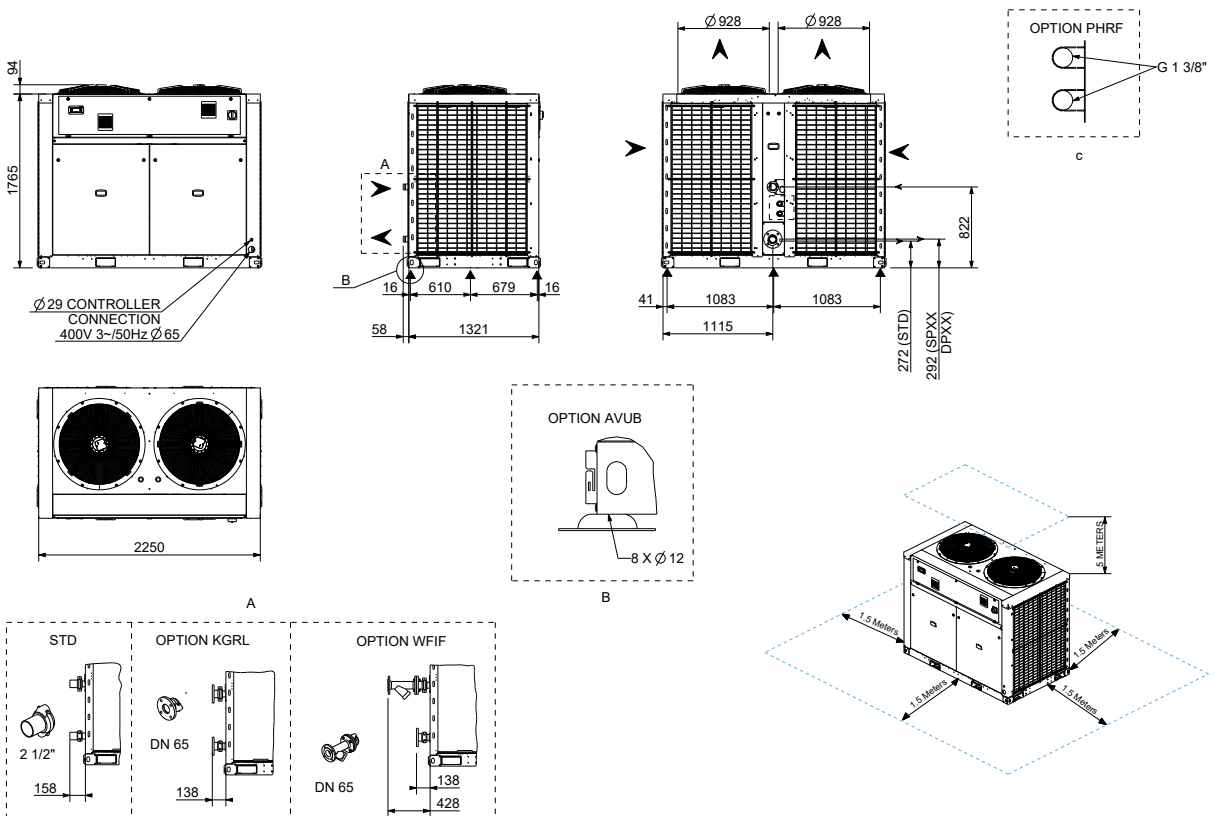

All dimensions in millimeters

**GAC/H 125S - 140S**

**STANDARD VERSION (EC FAN) AND HIGH PRESSURE EC FAN (HIPF)**

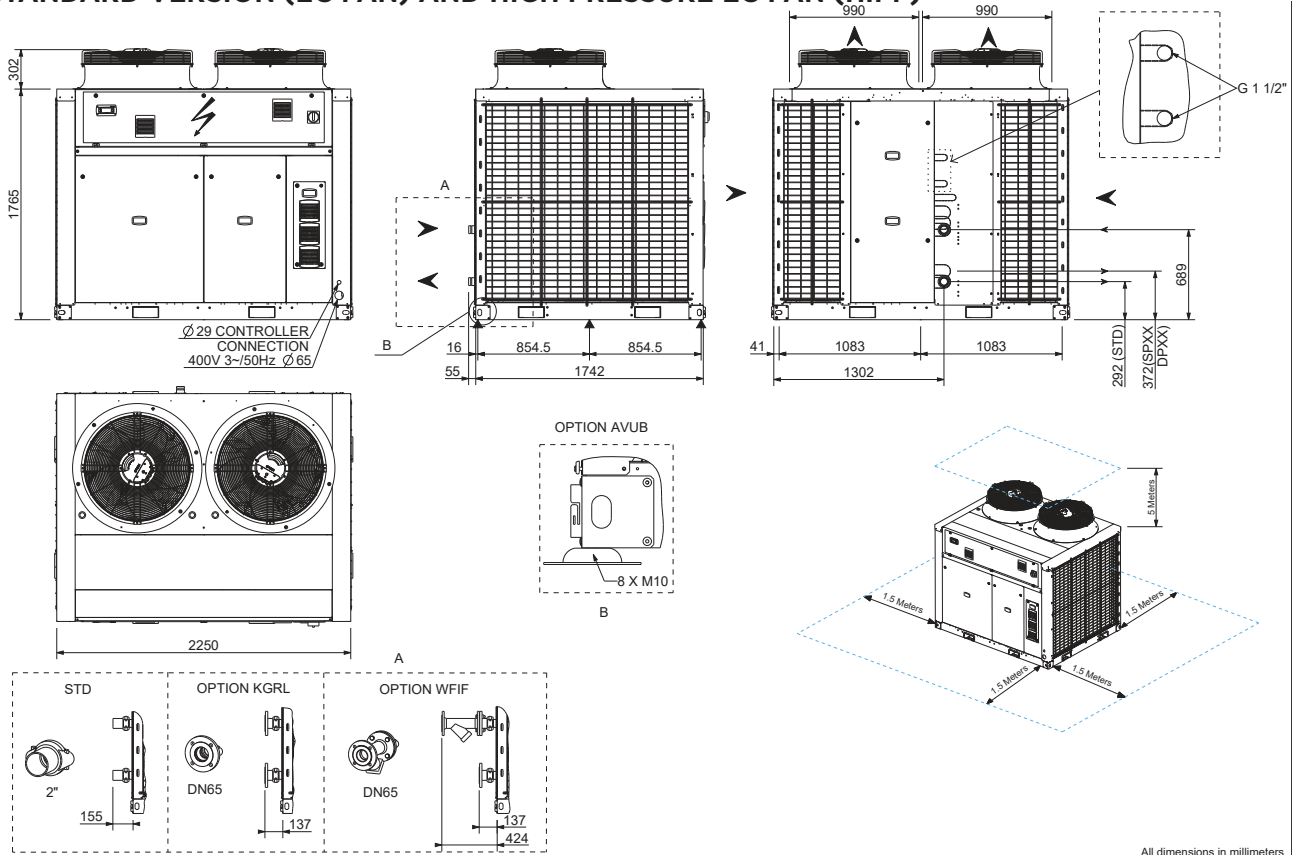

**UNIT WITH AC FAN (SFAC)**

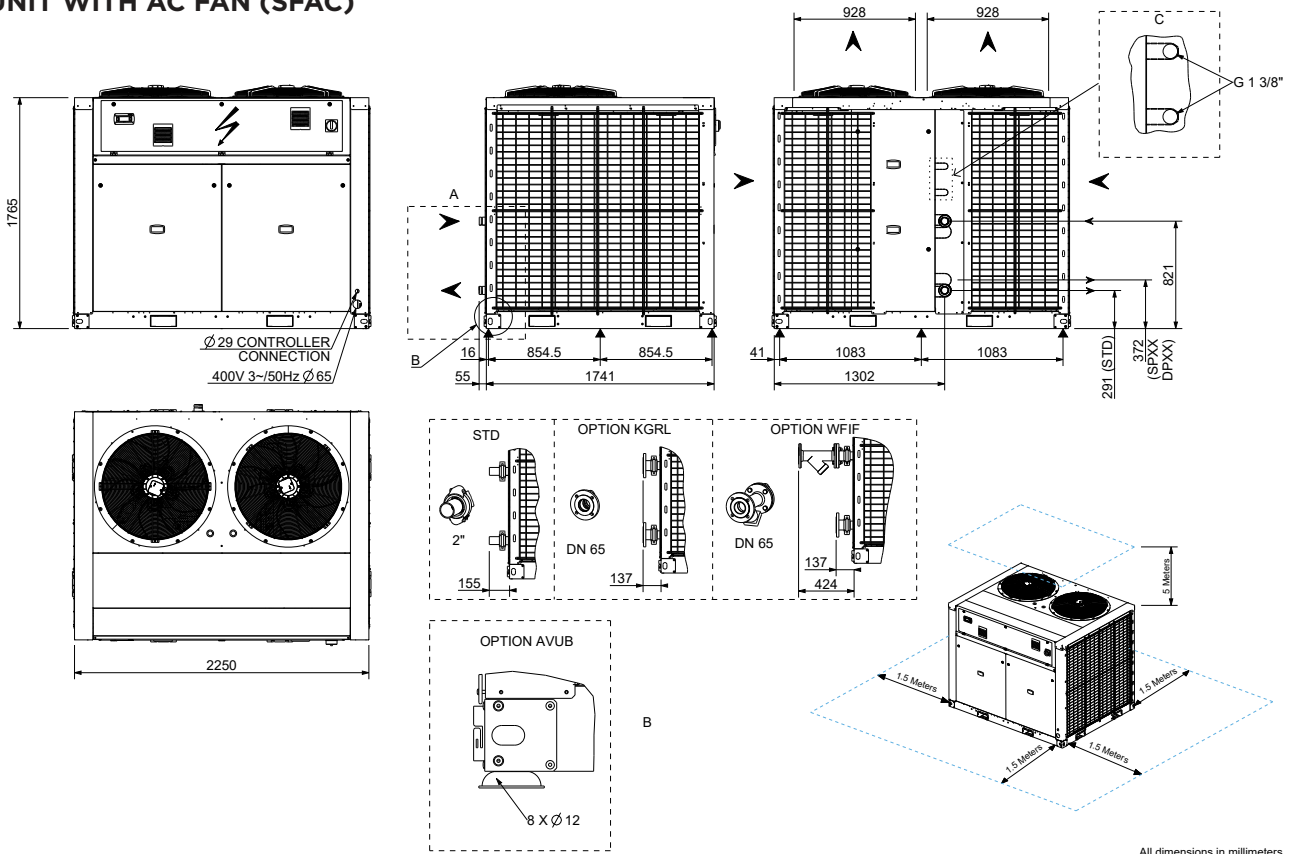



**GAC/H 160D - 185D - 210D**

**STANDARD VERSION (EC FAN) AND HIGH PRESSURE EC FAN (HIPF)**

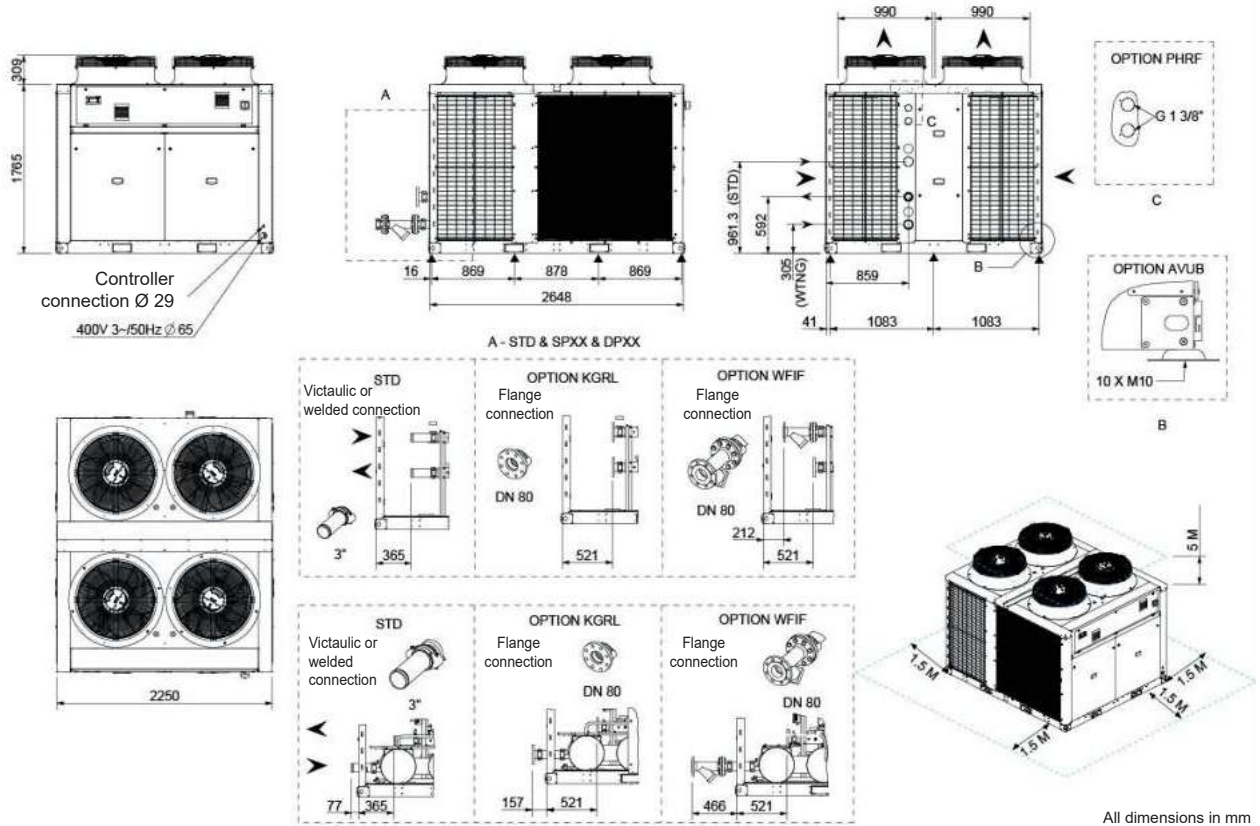

**UNIT WITH AC FAN (SFAC)**

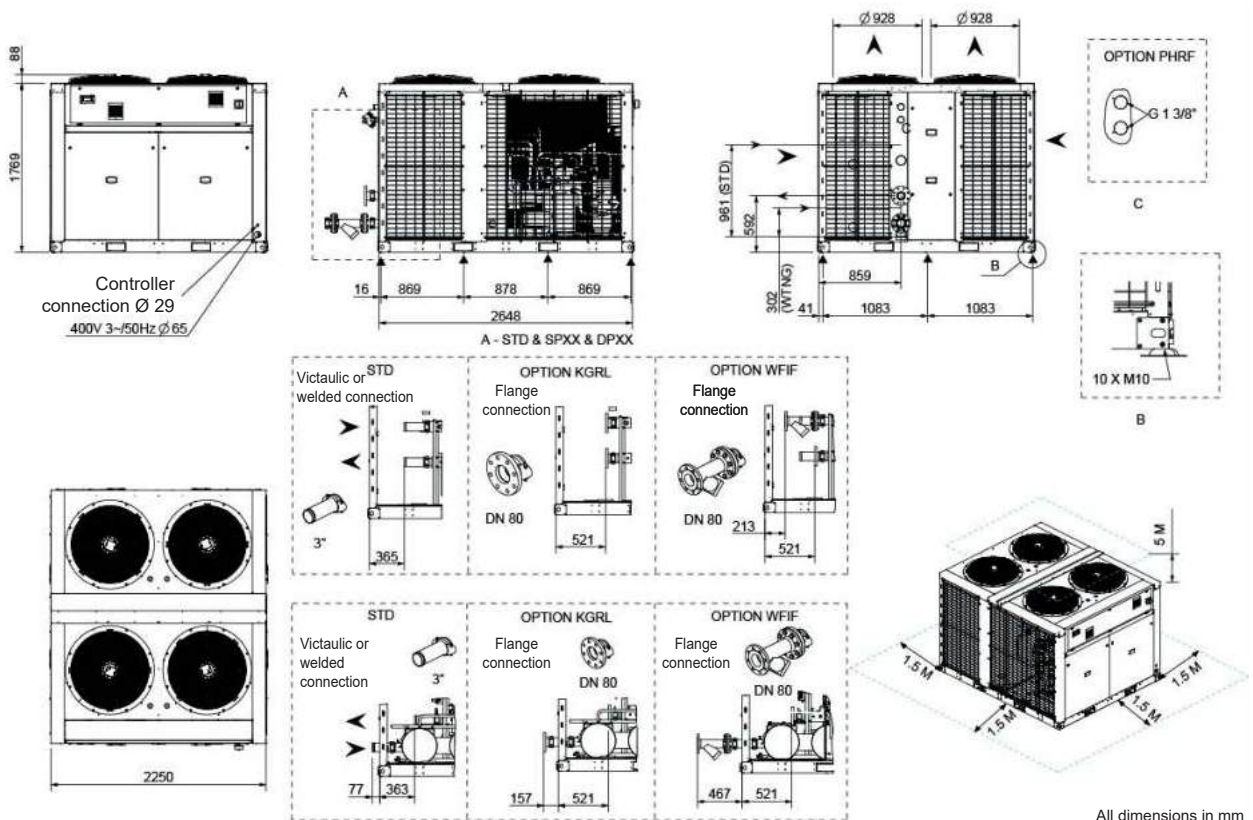

**GBC/H 040S**

**STANDARD VERSION (EC FAN) AND HIGH PRESSURE EC FAN (HIPF)**

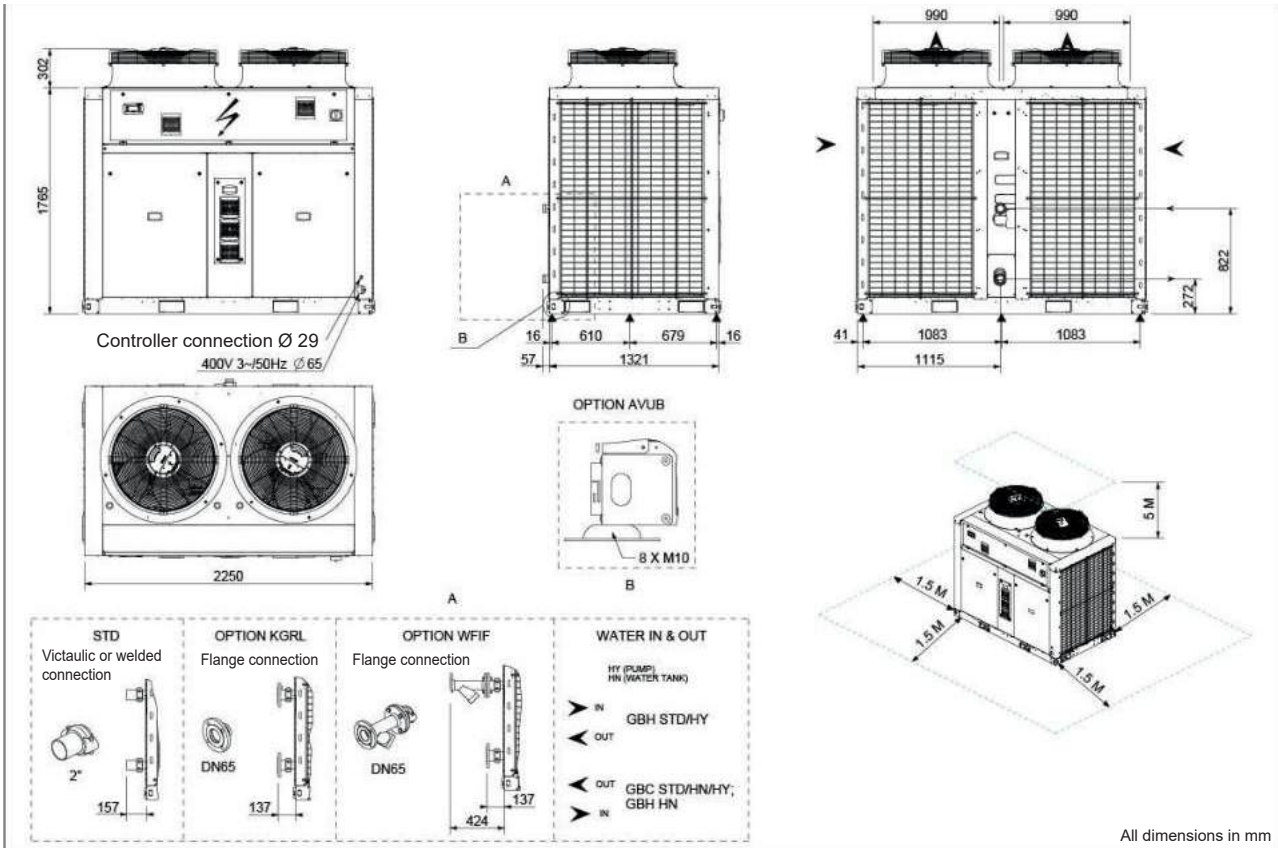

**GBC/H 060S**

**STANDARD VERSION OR WITH HIGH PRESSURE EC FANS (HIPF)**

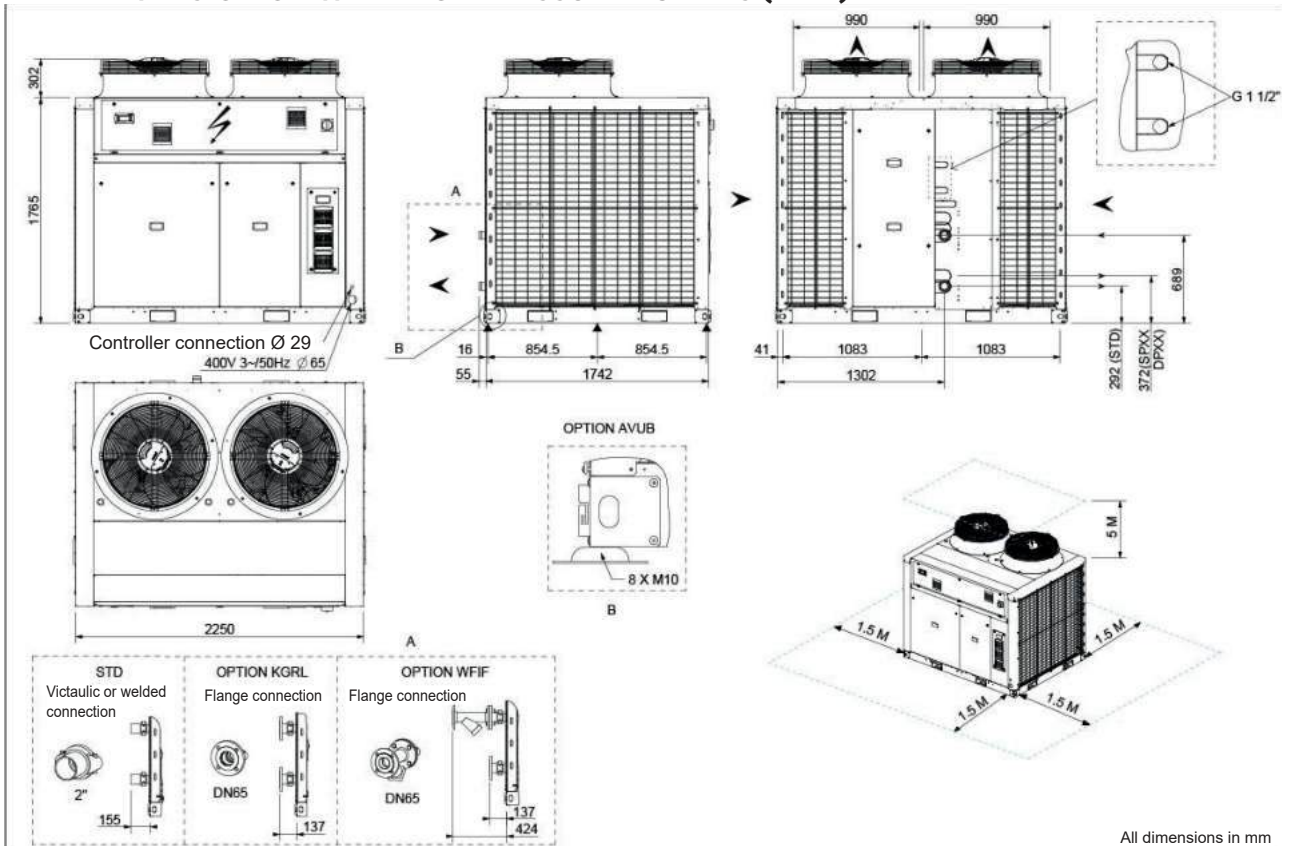

**GBC/H 070D**

**STANDARD VERSION (EC FAN) AND HIGH PRESSURE EC FAN (HIPF)**

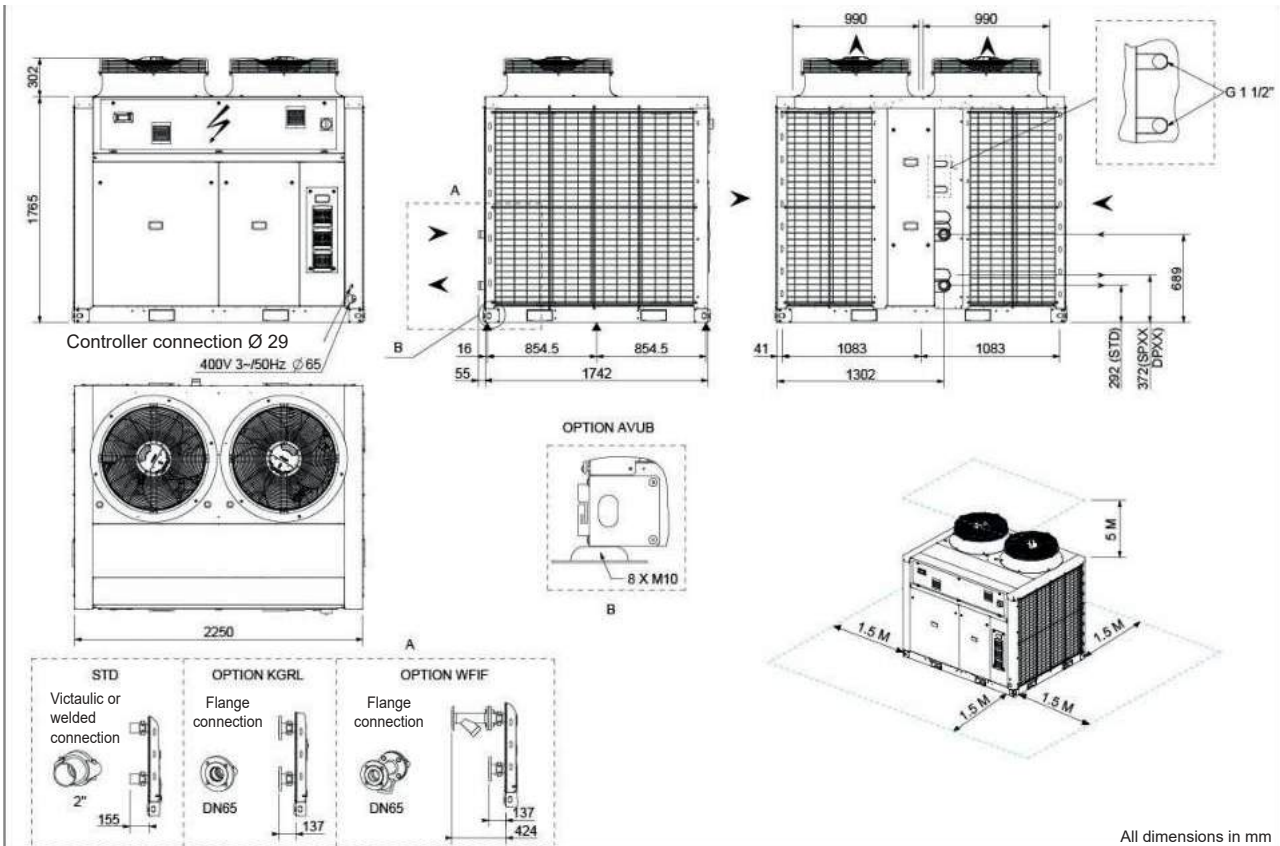

All dimensions in mm

**GBC/H 080S**

**STANDARD VERSION (EC FAN) AND HIGH PRESSURE EC FAN (HIPF)**

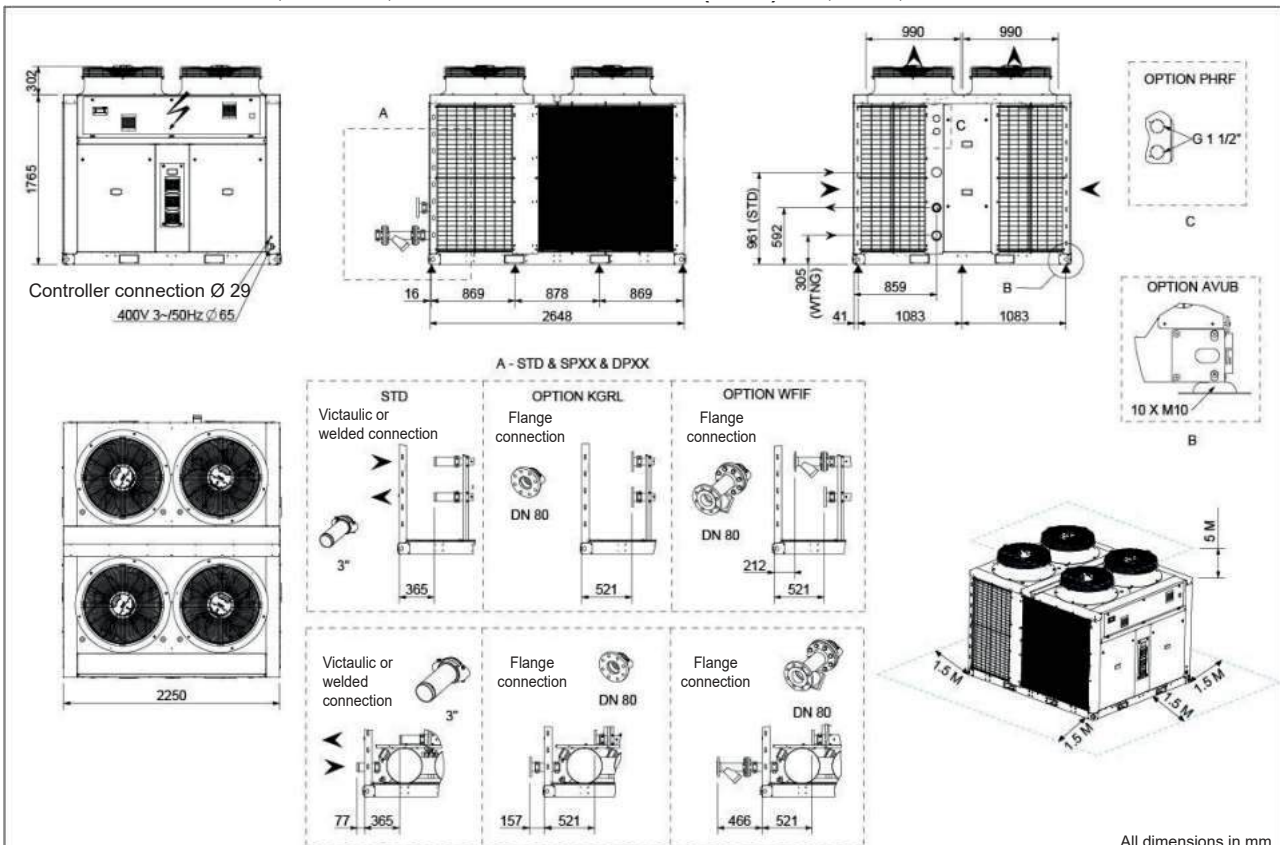

All dimensions in mm

**GBC/H 110S-120S**

**STANDARD VERSION (EC FAN) AND HIGH PRESSURE EC FAN (HIPF)**

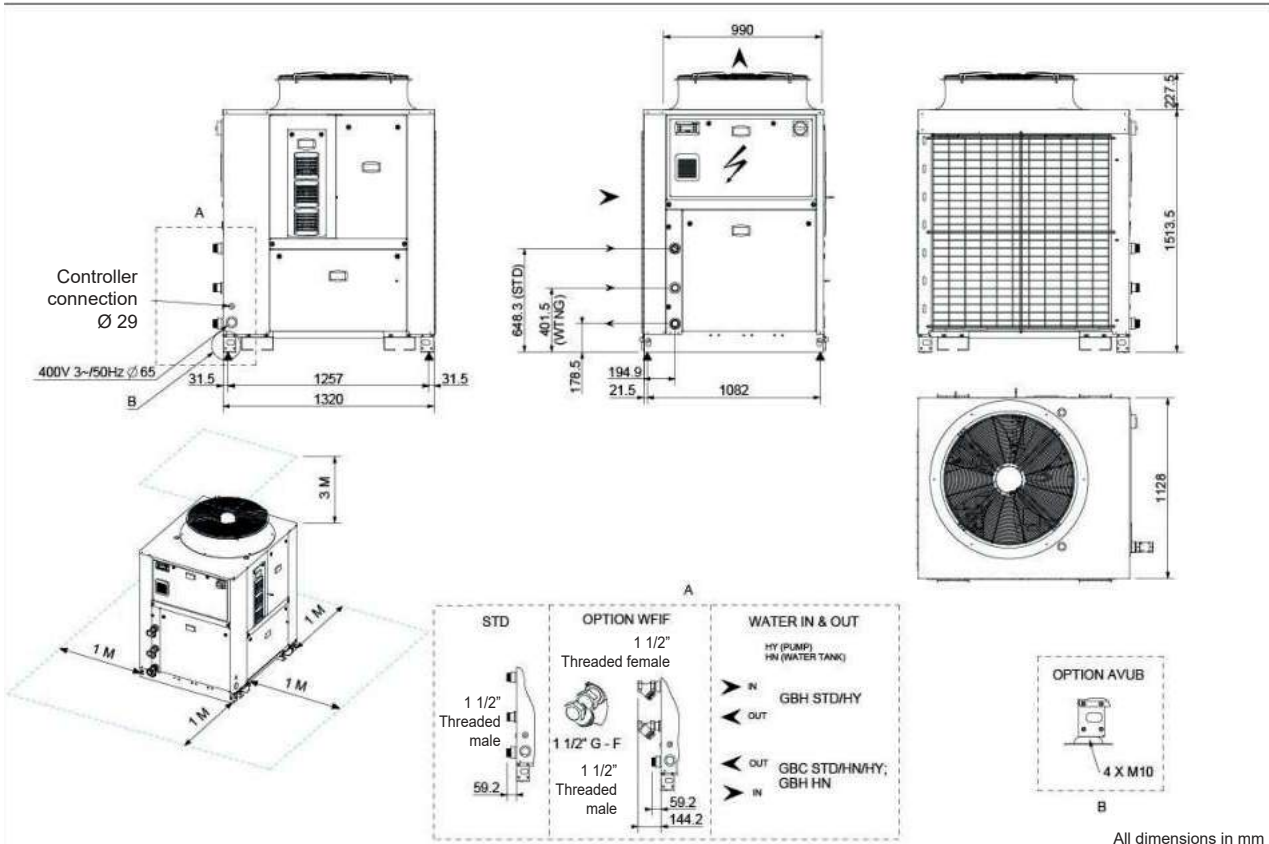

All dimensions in mm

**GBC 125D-140D**

**STANDARD VERSION OR WITH HIGH PRESSURE EC FANS (HIPF)**

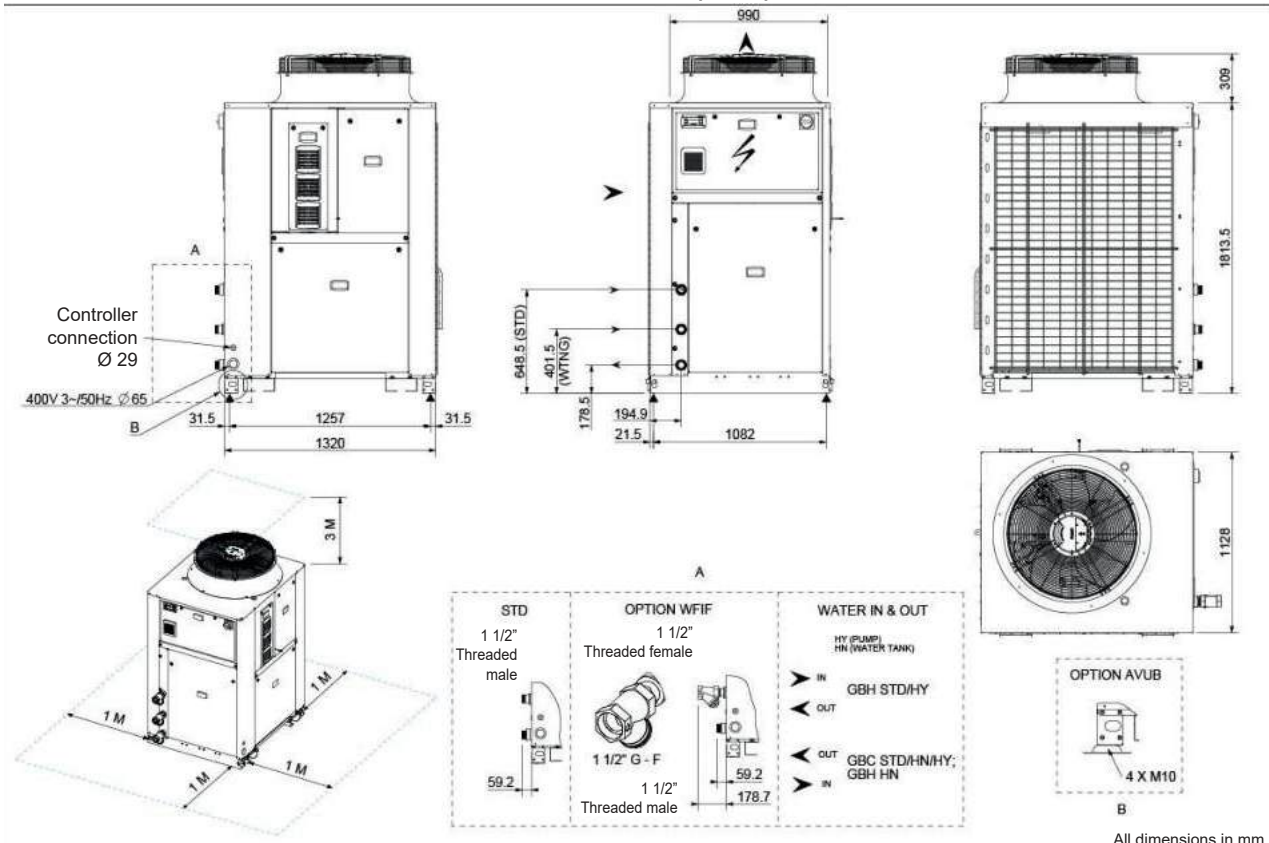

All dimensions in mm

**GBH 125D-140D**

**STANDARD VERSION (EC FAN) AND HIGH PRESSURE EC FAN (HIPF)**

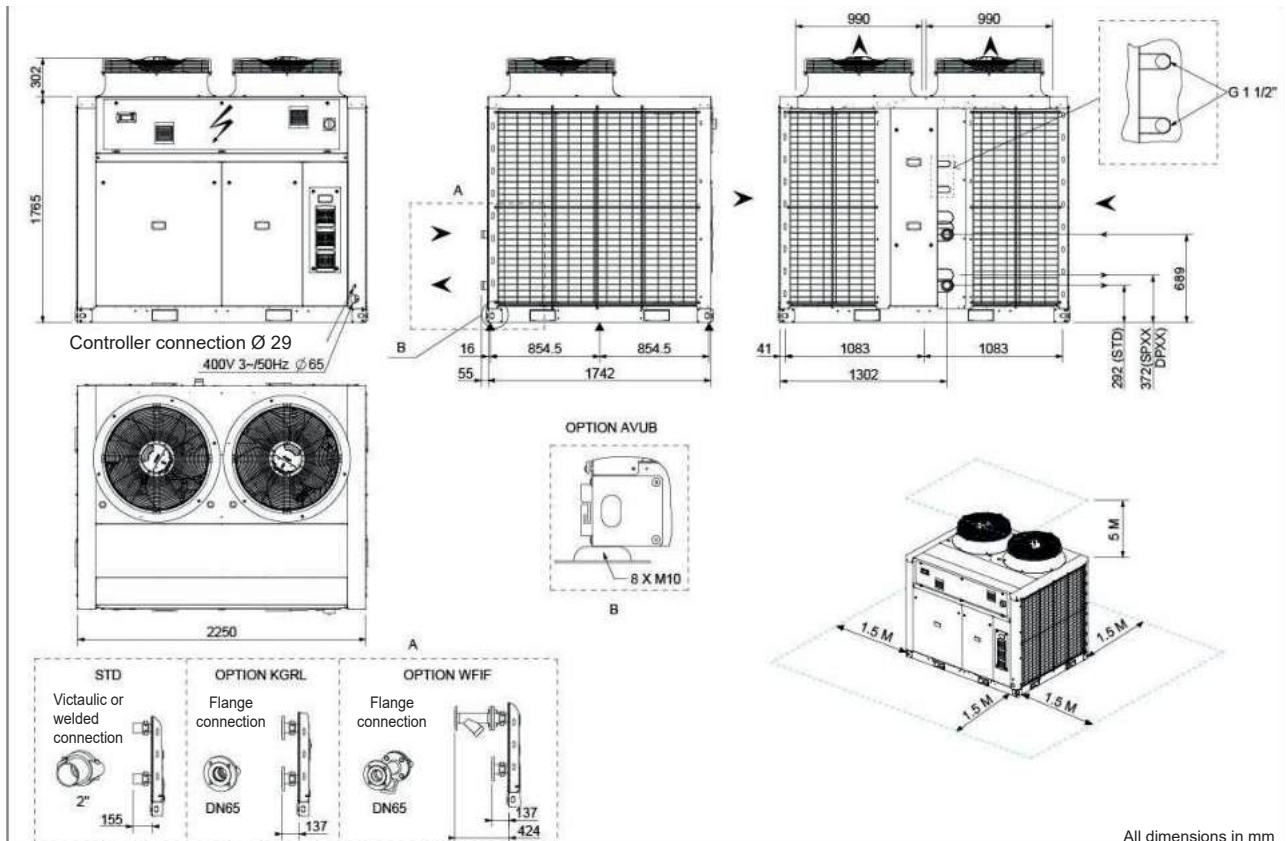

All dimensions in mm

**GBC/H 160D-185D-210D**

**STANDARD VERSION (EC FAN) AND HIGH PRESSURE EC FAN (HIPF)**

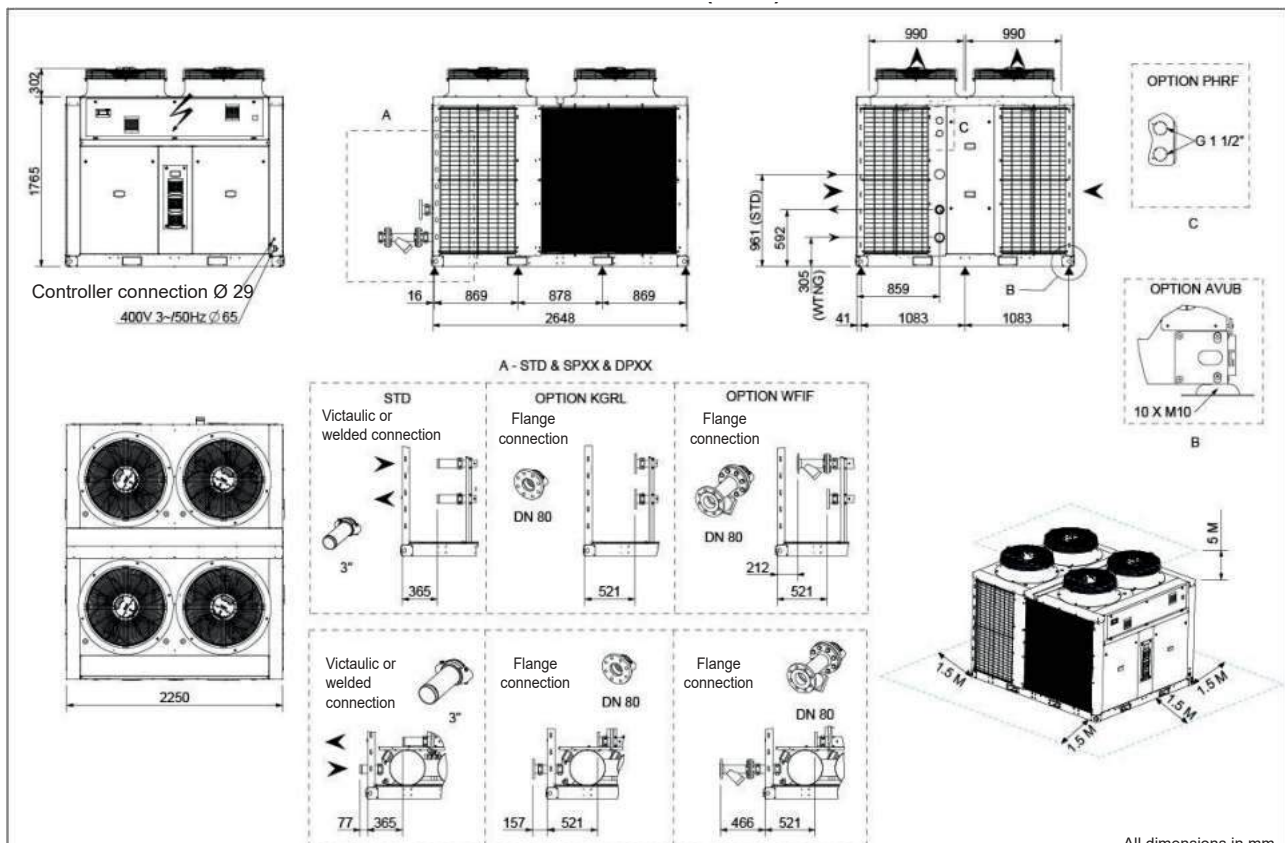

All dimensions in mm

Due to LENNOX EMEA ongoing commitment to quality, the specifications, ratings and dimensions are subject to change without notice and without incurring liability.

Improper installation, adjustment, alteration, service or maintenance can cause property damage or personal injury.

Installation and service must be performed by a qualified installer and servicing agency.



brand of LENNOX EMEA

**Headquarters LENNOX EMEA**

7 rue des Albatros - Z.I. Les Meurières, 69780 Mions - France

+33 (0) 810 502 502

[www.lennoxemea.com](http://www.lennoxemea.com)

