

LG

MULTI V™ S

Heat Pump 380-415V + 380V
R410A(50Hz/60Hz)
0CVM0-01A

TOTAL HVAC SOLUTION PROVIDER

ENGINEERING PRODUCT DATA BOOK



LG participates in the ECP programme for EUROVENT VRF program.
Check ongoing validity of certification : www.eurovent-certification.com



P/No. : MFL67474080

MULTI V™ S
Outdoor Unit

General information

Product Data

Installation of Outdoor Units

Special Guide



MULTI V™ S
Outdoor Unit

General information



- 1. Model Line-up & External Appearance**
- 2. Nomenclature**

1. Model Line-up & External Appearance

◆ 1 Phase

Chassis	Model Name		External Appearance
	Standard	Compact	
U4	ARUN040GSS0	ARUN050GSL0	
U3	ARUN050GSS0 ARUN060GSS0	-	

◆ 3 Phase

Chassis	Model Name		External Appearance
	Standard		
U3	ARUN040LSS0 ARUN050LSS0 ARUN060LSS0 ARUN080LSS0		
U7	ARUN100LSS0 ARUN120LSS0		

2. Nomenclature

Model Name	ARU	N	100	L	S	S	0
No.	1	2	3	4	5	6	7

No.	Signification
1	MULTI V System Outdoor Unit using R410A
2	Combination of Inverter Type and Cooling Only or Heat Pump N: Inverter and H/P, V: Inverter and C/O
3	Total Cooling Capacity in Horse Power (HP) unit EX) 8HP → '080', 10HP → '100'
4	Electrical Ratings L : 3Ø, 380-415V, 50Hz / 3Ø, 380V, 60Hz G : 1Ø, 220-240V, 50Hz / 1Ø, 220V, 60Hz
5	Air Discharge Type S : Side Discharge
6	Model Type S : Standard L : Compact
7	Serial number

MULTI V™ S

Outdoor Unit

Product Data

- 1. List of Functions**
- 2. Specifications**
- 3. Dimensions**
- 4. Electric Characteristics**
- 5. Indoor Unit and Outdoor Unit Capacity Index**
- 6. Capacity Tables**
- 7. Capacity Correction Factor**
- 8. Operation Limits**
- 9. Piping Diagrams**
- 10. Wiring Diagrams**
- 11. Field Wiring**
- 12. Sound Levels**

1. List of Functions

Basic functions

Category	Functions	Multi V S	
		1 Phase	3 Phase
Reliability	Defrost / Deicing	O	O
	High pressure switch	O	O
	Phase protection	X	O
	Restart delay (3-minutes)	O	O
	Self diagnosis	O	O
	Soft start	O	O
	Test Run function	X	X
Convenience	Night Low Noise Operation	O	O
CAC network function	Network solution(LGAP)	O	O

Note

1. O : Applied X : Not applied

Network solution Accessory List

	Device	Accessory Model Name
Central Controller	AC Ez (Simple Controller)	PQCSZ250S0
	AC Ez Touch	PACEZA000
	AC Smart IV	PACS4B000
	AC Smart 5	PACS5A000
	ACP(Advanced Control Platform) IV	PACP4B000
	ACP(Advanced Control Platform) 5	PACP5A000
	AC Manager 5	PACM5A000
	ACS IO Module	PEXPMB000
	DO(Digital Output) Kit	PQNFP00T0
BNU (Building Network Unit)	ACP Lonworks	PLNWKB000
	ACP BACnet	PQNFB17C0
Installation	Refrigerant Charging Kit	O (Logical operation)
PDI (Power Distribution Indicator)	Standard	PPWRDB000
	Premium	PQNUD1S40
Cool / Heat Selector		PRDSBM
Low Ambient Kit		PRVC2
IO Module (ODU Dry Contact)		PVDSMN000
Cycle Monitoring Device	LGMV	PRCTIL0
	Mobile LGMV	PLGMVW100
DS(Data Saving) Module		PVADTN000

Note

1. O : Applied, X : Not applied

Accessory : Ordered and purchased separately the accessory package referring to the model name provided and install at field.

Accessory line-ups varies by region, so check your local catalogue or local sales material.

2. Specifications

1 Phase / Heat Pump

HP			4	5
Model Name			ARUN040GSS0	ARUN050GSL0
Capacity	Cooling	kW	12.1	14.0
		kcal/h	10,400	12,000
		Btu/h	41,300	47,800
	Heating	kW	12.5	15.0
		kcal/h	10,800	12,900
		Btu/h	42,700	51,200
Input (Rated)	Cooling	kW	4.03	5.34
	Heating	kW	3.10	3.98
EER			3.00	2.62
SEER			5.63	6.19
COP			4.03	3.77
SCOP			3.97	4.21
Power Factor	Rated	-	0.93	0.93
Exterior	Color		Warm Gray	Warm Gray
	RAL (Classis)		RAL 7044	RAL 7044
Heat Exchanger			Wide Louver Plus	Wide Louver Plus
Compressor	Type		BLDC Inverter Twin Rotary	BLDC Inverter Twin Rotary
	Piston Displacement	cm ³ /rev	44.2	44.2
	Number of Revolution	rev/min	3,600	3,600
	Motor Output	W	4,000	4,000
	Starting Method		Inverter	Inverter
	Oil Type		FW68D(PVE)	FW68D(PVE)
	Oil Charge		1,300	1,300
Fan	Type		Axial Flow Fan	Axial Flow Fan
	Motor Output x Number	W	124 x 1	124 x 1
	Air Flow Rate(High)	m ³ /min	60	60
		ft ³ /min	2,119	2,119
	Drive		DC INVERTER	DC INVERTER
Pipe Connections	Liquid	mm(inch)	Ø 9.52(3/8)	Ø 9.52(3/8)
	Gas	mm(inch)	Ø 15.88(5/8)	Ø 15.88(5/8)
Dimensions(W x H x D)		mm	950 × 834 × 330	950 × 834 × 330
		inch	37-13/32 × 32-27/32 × 13	37-13/32 × 32-27/32 × 13
Net Weight		kg	70	73
		lbs	154	161
Sound Pressure Level	Cooling	dB(A)	50	52
	Heating	dB(A)	52	58
Sound Power Level	Cooling	dB(A)	72	72
	Heating	dB(A)	75	75
Protection Devices	High pressure protection	-	High pressure sensor	High pressure sensor
	Compressor/ Fan	-	Over-heat protection / Fan driver overload protector	Over-heat protection / Fan driver overload protector
	Inverter	-	Over-heat protection / Over-current protection	Over-heat protection / Over-current protection
Communication Cable (VCTF-SB)		No. x mm ²	2C x 1.0 ~ 1.5	2C x 1.0 ~ 1.5
Refrigerant	Refrigerant name		R410A	R410A
	Precharged Amount	kg	1.8	2.4
		lbs	4.0	5.3
	t-CO ₂ eq.		3.758	5.010
Control			Electronic Expansion Valve	Electronic Expansion Valve
Power Supply		V, Ø, Hz	220 - 230 - 240 , 1 , 50/60	220 - 230 - 240 , 1 , 50/60
Running Current	Cooling	A	19.70 - 18.84 - 18.06	26.10 - 24.96 - 23.92
	Heating	A	15.15 - 14.49 - 13.89	19.45 - 18.61 - 17.83
Number of maximum connectable indoor units			8	8*

Note

- Due to our policy of innovation some specifications may be changed without notification.
- Wiring cable size must comply with the applicable local and national codes. And "Electric characteristics" chapter should be considered for electrical work and design. Especially the power cable and circuit breaker should be selected in accordance with that.
- Sound pressure level is measured on the rated condition in the anechoic rooms by ISO 3745 standard.
Sound power level is measured on the rated condition in the semi-anechoic rooms by ISO 9614 standard.
Therefore, these values can be increased owing to ambient conditions during operation.
- Performances are based on the following conditions :
 - *Cooling : Indoor Ambient Temp. 27°CDB / 19°CWB, Outdoor Ambient Temp. 35°CDB / 24°CWB
 - *Heating : Indoor Ambient Temp. 20°CDB / 15°CWB, Outdoor Ambient Temp. 7°CDB / 6°CWB
 - Interconnected Pipe Length is 7.5m and difference of Elevation (Outdoor ~ Indoor Unit) is 0m.
- EUROVENT Test Condition :
 - Performance values in this PDB are based on Ceiling mounted cassette combination.
 - Refer to EUROVENT web site(www.eurovent-certification.com) for other indoor unit combination and more detail test conditions.
- The maximum combination ratio is 160%.
- This product contains Fluorinated greenhouse gases.
- * : In case of ARUN050GSL0, maximum combination ratio is 130%.

2. Specifications

HP			5	6
Model Name			ARUN050GSS0	ARUN060GSS0
Capacity	Cooling	kW	14.0	15.5
		kcal/h	12,000	13,300
		Btu/h	47,800	52,900
	Heating	kW	16.0	18.0
		kcal/h	13,800	15,500
Btu/h		54,600	61,400	
Input (Rated)	Cooling	kW	4.59	5.17
	Heating	kW	4.18	5.00
EER			3.05	3.00
SEER			7.40	7.53
COP			3.83	3.60
SCOP			4.16	4.35
Power Factor	Rated	-	0.93	0.93
Exterior	Color		Warm Gray	Warm Gray
	RAL (Classis)		RAL 7044	RAL 7044
Heat Exchanger			Wide Louver Plus	Wide Louver Plus
Compressor	Type		BLDC Inverter Twin Rotary	BLDC Inverter Twin Rotary
	Piston Displacement	cm ³ /rev	44.2	44.2
	Number of Revolution	rev/min	3,600	3,600
	Motor Output	W	4,000	4,000
	Starting Method		Inverter	Inverter
	Oil Type		FW68D(PVE)	FW68D(PVE)
	Oil Charge		1,300	1,300
Fan	Type		Axial Flow Fan	Axial Flow Fan
	Motor Output x Number	W	124 x 2	124 x 2
	Air Flow Rate(High)	m ³ /min	110	110
		ft ³ /min	3,885	3,885
	Drive		DC INVERTER	DC INVERTER
Pipe Connections	Discharge	Side / Top	Side	Side
	Liquid	mm(inch)	Ø 9.52(3/8)	Ø 9.52(3/8)
	Gas	mm(inch)	Ø 15.88(5/8)	Ø 19.05(3/4)
Dimensions(W x H x D)		mm	950 x 1,380 x 330	950 x 1,380 x 330
		inch	37-13/32 x 54-11/32 x 13	37-13/32 x 54-11/32 x 13
Net Weight		kg	94	94
		lbs	207	207
Sound Pressure Level	Cooling	dB(A)	51	52
	Heating	dB(A)	53	54
Sound Power Level	Cooling	dB(A)	72	72
	Heating	dB(A)	76	77
Protection Devices	High pressure protection	-	High pressure sensor	High pressure sensor
	Compressor/ Fan	-	Over-heat protection / Fan driver overload protector	Over-heat protection / Fan driver overload protector
	Inverter	-	Over-heat protection / Over-current protection	Over-heat protection / Over-current protection
Communication Cable (VCTF-SB)		No. x mm ²	2C x 1.0 ~ 1.5	2C x 1.0 ~ 1.5
Refrigerant	Refrigerant name		R410A	R410A
	Precharged Amount	kg	3.0	3.0
		lbs	6.6	6.6
	t-CO ₂ eq.		6.263	6.263
Control			Electronic Expansion Valve	Electronic Expansion Valve
Power Supply		V, Ø, Hz	220 - 230 - 240 , 1 , 50/60	220 - 230 - 240 , 1 , 50/60
Running Current	Cooling	A	22.43 - 21.46 - 20.56	25.27 - 24.17 - 23.16
	Heating	A	20.43 - 19.54 - 18.73	24.44 - 23.38 - 22.40
Number of maximum connectable indoor units			10	13

Note

- Due to our policy of innovation some specifications may be changed without notification.
- Wiring cable size must comply with the applicable local and national codes. And "Electric characteristics" chapter should be considered for electrical work and design. Especially the power cable and circuit breaker should be selected in accordance with that.
- Sound pressure level is measured on the rated condition in the anechoic rooms by ISO 3745 standard.
Sound power level is measured on the rated condition in the semi-anechoic rooms by ISO 9614 standard.
Therefore, these values can be increased owing to ambient conditions during operation.
- Performances are based on the following conditions :
 - *Cooling : Indoor Ambient Temp. 27°CDB / 19°CWB, Outdoor Ambient Temp. 35°CDB / 24°CWB
 - *Heating : Indoor Ambient Temp. 20°CDB / 15°CWB, Outdoor Ambient Temp. 7°CDB / 6°CWB
 - Interconnected Pipe Length is 7.5m and difference of Elevation (Outdoor ~ Indoor Unit) is 0m.
- EUROVENT Test Condition :
 - Performance values in this PDB are based on Ceiling mounted cassette combination.
 - Refer to EUROVENT web site(www.eurovent-certification.com) for other indoor unit combination and more detail test conditions.
- The maximum combination ratio is 160%.
- This product contains Fluorinated greenhouse gases.
- * : In case of ARUN050GSL0, maximum combination ratio is 130%.

2. Specifications

3 Phase / Heat Pump

HP			4	5
Model Name			ARUN040LSS0	ARUN050LSS0
Capacity	Cooling	kW	12.1	14.0
		kcal/h	10,400	12,000
		Btu/h	41,300	47,800
	Heating	kW	12.5	16.0
		kcal/h	10,800	13,800
Btu/h		42,700	54,600	
Input (Rated)	Cooling	kW	3.39	4.59
	Heating	kW	2.75	4.18
EER			3.57	3.05
SEER			7.42	7.40
COP			4.55	3.83
SCOP			4.30	4.16
Power Factor	Rated	-	0.93	0.93
Exterior	Color		Warm Gray	Warm Gray
	RAL (Classis)		RAL 7044	RAL 7044
Heat Exchanger			Wide Louver Plus	Wide Louver Plus
Compressor	Type		BLDC Inverter Twin Rotary	BLDC Inverter Twin Rotary
	Piston Displacement	cm ³ /rev	44.2	44.2
	Number of Revolution	rev/min	3,600	3,600
	Motor Output	W	4,000	4,000
	Starting Method		Inverter	Inverter
	Oil Type		FW68D(PVE)	FW68D(PVE)
	Oil Charge		1,300	1,300
Fan	Type		Axial Flow Fan	Axial Flow Fan
	Motor Output x Number	W	124 x 2	124 x 2
	Air Flow Rate(High)	m ³ /min	110	110
		ft ³ /min	3,885	3,885
	Drive		DC INVERTER	DC INVERTER
Discharge		Side / Top	Side	
Pipe Connections	Liquid	mm(inch)	Ø 9.52(3/8)	Ø 9.52(3/8)
	Gas	mm(inch)	Ø 15.88(5/8)	Ø 15.88(5/8)
Dimensions(W x H x D)		mm	950 × 1,380 × 330	950 × 1,380 × 330
		inch	37-13/32 × 54-11/32 × 13	37-13/32 × 54-11/32 × 13
Net Weight		kg	96	96
		lbs	212	212
Sound Pressure Level	Cooling	dB(A)	50	51
	Heating	dB(A)	52	53
Sound Power Level	Cooling	dB(A)	72	72
	Heating	dB(A)	76	76
Protection Devices	High pressure protection		High pressure sensor	High pressure sensor
	Comperssor/ Fan		Over-heat protection / Fan driver overload protector	Over-heat protection / Fan driver overload protector
	Inverter		Over-heat protection / Over-current protection	Over-heat protection / Over-current protection
Communication Cable (VCTF-SB)		No. x mm ²	2C x 1.0 ~ 1.5	2C x 1.0 ~ 1.5
Refrigerant	Refrigerant name		R410A	R410A
	Precharged Amount	kg	3.0	3.0
		lbs	6.6	6.6
	t-CO ₂ eq.		6.263	6.263
Control		Electronic Expansion Valve	Electronic Expansion Valve	
Power Supply		V, Ø, Hz	220 - 230 - 240 , 1 , 50/60	220 - 230 - 240 , 1 , 50/60
Running Current	Cooling	A	5.54 - 5.26 - 5.07	7.50 - 7.12 - 6.87
	Heating	A	4.49 - 4.27 - 4.11	6.83 - 6.49 - 6.25
Number of maximum connectable indoor units			8	10

Note

- Due to our policy of innovation some specifications may be changed without notification.
- Wiring cable size must comply with the applicable local and national codes. And "Electric characteristics" chapter should be considered for electrical work and design. Especially the power cable and circuit breaker should be selected in accordance with that.
- Sound pressure level is measured on the rated condition in the anechoic rooms by ISO 3745 standard.
Sound power level is measured on the rated condition in the semi-anechoic rooms by ISO 9614 standard.
Therefore, these values can be increased owing to ambient conditions during operation.
- Performances are based on the following conditions :
 - *Cooling : Indoor Ambient Temp. 27°CDB / 19°CWB, Outdoor Ambient Temp. 35°CDB / 24°CWB
 - *Heating : Indoor Ambient Temp. 20°CDB / 15°CWB, Outdoor Ambient Temp. 7°CDB / 6°CWB
 - Interconnected Pipe Length is 7.5m and difference of Elevation (Outdoor ~ Indoor Unit) is 0m.
- EUROVENT Test Condition :
 - Performance values in this PDB are based on Ceiling mounted cassette combination.
 - Refer to EUROVENT web site(www.eurovent-certification.com) for other indoor unit combination and more detail test conditions.
- The maximum combination ratio is 160%.
- This product contains Fluorinated greenhouse gases.
- * : In case of ARUN050GSL0, maximum combination ratio is 130%.

2. Specifications

HP			6	8
Model Name			ARUN060LSS0	ARUN080LSS0
Capacity	Cooling	kW	15.5	22.4
		kcal/h	13,300	19,300
		Btu/h	52,900	76,400
	Heating	kW	18.0	24.5
		kcal/h	15,500	21,100
Btu/h		61,400	83,600	
Input (Rated)	Cooling	kW	5.17	8.45
	Heating	kW	5.00	6.96
EER			3.00	2.65
SEER			7.53	7.13
COP			3.60	3.52
SCOP			4.35	4.53
Power Factor	Rated	-	0.93	0.93
Exterior	Color		Warm Gray	Warm Gray
	RAL (Classis)		RAL 7044	RAL 7044
Heat Exchanger			Wide Louver Plus	Wide Louver Plus
Compressor	Type		BLDC Inverter Twin Rotary	Hermetically Sealed Scroll
	Piston Displacement	cm ³ /rev	44.2	43.8
	Number of Revolution	rev/min	3,600	3,600
	Motor Output	W	4,000	4,200
	Starting Method		Inverter	Inverter
	Oil Type		FW68D(PVE)	FW68D(PVE)
	Oil Charge		1,300	2,400
Fan	Type		Axial Flow Fan	Propeller fan
	Motor Output x Number	W	124 x 2	124 x 2
	Air Flow Rate(High)	m ³ /min	110	140
		ft ³ /min	3,885	4,944
	Drive		DC INVERTER	DC INVERTER
Discharge		Side / Top	Side	
Pipe Connections	Liquid	mm(inch)	Ø 9.52(3/8)	Ø 9.52(3/8)
	Gas	mm(inch)	Ø 19.05(3/4)	Ø 19.05(3/4)
Dimensions(W x H x D)		mm	950 x 1,380 x 330	950 x 1,380 x 330
		inch	37-13/32 x 54-11/32 x 13	37-13/32 x 54-11/32 x 13
Net Weight		kg	96	115
		lbs	212	254
Sound Pressure Level	Cooling	dB(A)	52	57
	Heating	dB(A)	54	57
Sound Power Level	Cooling	dB(A)	72	78
	Heating	dB(A)	77	81
Protection Devices	High pressure protection		-	High pressure sensor
	Compressor/ Fan		-	Over-heat protection / Fan driver overload protector
	Inverter		-	Over-heat protection / Over-current protection
Communication Cable (VCTF-SB)		No. x mm ²	2C x 1.0 ~ 1.5	2C x 1.0 ~ 1.5
Refrigerant	Refrigerant name		R410A	R410A
	Precharged Amount	kg	3.0	3.5
		lbs	6.6	7.7
	t-CO ₂ eq.		6.263	7.306
Control		Electronic Expansion Valve	Electronic Expansion Valve	
Power Supply		V, Ø, Hz	380 - 400 - 415, 3, 50/60	380 - 400 - 415, 3, 50/60
Running Current	Cooling	A	8.45 - 8.02 - 7.73	13.8 - 13.11 - 12.64
	Heating	A	8.17 - 7.76 - 7.48	11.37 - 10.80 - 10.41
Number of maximum connectable indoor units			13	13

Note

- Due to our policy of innovation some specifications may be changed without notification.
- Wiring cable size must comply with the applicable local and national codes. And "Electric characteristics" chapter should be considered for electrical work and design. Especially the power cable and circuit breaker should be selected in accordance with that.
- Sound pressure level is measured on the rated condition in the anechoic rooms by ISO 3745 standard.
Sound power level is measured on the rated condition in the semi-anechoic rooms by ISO 9614 standard.
Therefore, these values can be increased owing to ambient conditions during operation.
- Performances are based on the following conditions :
 - *Cooling : Indoor Ambient Temp. 27°CDB / 19°CWB, Outdoor Ambient Temp. 35°CDB / 24°CWB
 - *Heating : Indoor Ambient Temp. 20°CDB / 15°CWB, Outdoor Ambient Temp. 7°CDB / 6°CWB
 - Interconnected Pipe Length is 7.5m and difference of Elevation (Outdoor ~ Indoor Unit) is 0m.
- EUROVENT Test Condition :
 - Performance values in this PDB are based on Ceiling mounted cassette combination.
 - Refer to EUROVENT web site(www.eurovent-certification.com) for other indoor unit combination and more detail test conditions.
- The maximum combination ratio is 160%.
- This product contains Fluorinated greenhouse gases.
- * : In case of ARUN050GSL0, maximum combination ratio is 130%.

2. Specifications

HP			10	12
Model Name			ARUN100LSS0	ARUN120LSS0
Capacity	Cooling	kW	28.0	33.6
		kcal/h	24,100	28,900
		Btu/h	95,900	114,700
	Heating	kW	30.6	36.7
		kcal/h	26,300	31,600
Btu/h		104,400	125,200	
Input (Rated)	Cooling	kW	12.44	15.27
	Heating	kW	8.50	12.23
EER			2.25	2.20
SEER			6.28	6.50
COP			3.60	3.00
SCOP			4.21	4.32
Power Factor	Rated	-	0.93	0.93
Exterior	Color		Warm Gray	Warm Gray
	RAL (Classis)		RAL 7044	RAL 7044
Heat Exchanger			Wide Louver Plus	Wide Louver Plus
Compressor	Type		Hermetically Sealed Scroll	Hermetically Sealed Scroll
	Piston Displacement	cm ³ /rev	62.1	62.1
	Number of Revolution	rev/min	3,600	3,600
	Motor Output	W	5,300	5,300
	Starting Method		Inverter	Inverter
	Oil Type		FW68D(PVE)	FW68D(PVE)
	Oil Charge		2,600	3,400
Fan	Type		Propeller fan	Propeller fan
	Motor Output x Number	W	250 x 2	250 x 2
	Air Flow Rate(High)	m ³ /min	190	190
		ft ³ /min	6,710	6,710
	Drive		DC INVERTER	DC INVERTER
Discharge	Side / Top	Side	Side	
Pipe Connections	Liquid	mm(inch)	Ø 9.52(3/8)	Ø 12.7(1/2)
	Gas	mm(inch)	Ø 22.2(7/8)	Ø 28.58(1 1/8)
Dimensions(W x H x D)		mm	1,090 x 1,625 x 380	1,090 x 1,625 x 380
		inch	42-29/32 x 63-31/32 x 14-31/32	42-29/32 x 63-31/32 x 14-31/32
Net Weight		kg	142	155
		lbs	312	340
Sound Pressure Level	Cooling	dB(A)	58	60
	Heating	dB(A)	58	60
Sound Power Level	Cooling	dB(A)	77	78
	Heating	dB(A)	79	82
Protection Devices	High pressure protection	-	High pressure sensor	High pressure sensor
	Compressor/ Fan	-	Over-heat protection / Fan driver overload protector	Over-heat protection / Fan driver overload protector
	Inverter	-	Over-heat protection / Over-current protection	Over-heat protection / Over-current protection
Communication Cable (VCTF-SB)		No. x mm ²	2C x 1.0 ~ 1.5	2C x 1.0 ~ 1.5
Refrigerant	Refrigerant name		R410A	R410A
	Precharged Amount	kg	4.5	6.0
		lbs	9.9	13.2
	t-CO ₂ eq.		9.394	12.525
Control			Electronic Expansion Valve	Electronic Expansion Valve
Power Supply		V, Ø, Hz	380 - 400 - 415, 3, 50/60	380 - 400 - 415, 3, 50/60
Running Current	Cooling	A	20.32 - 19.31 - 18.61	24.95 - 23.7 - 22.84
	Heating	A	13.89 - 13.19 - 12.72	19.98 - 18.98 - 18.30
Number of maximum connectable indoor units			16	20

Note

- Due to our policy of innovation some specifications may be changed without notification.
- Wiring cable size must comply with the applicable local and national codes. And "Electric characteristics" chapter should be considered for electrical work and design. Especially the power cable and circuit breaker should be selected in accordance with that.
- Sound pressure level is measured on the rated condition in the anechoic rooms by ISO 3745 standard.
Sound power level is measured on the rated condition in the semi-anechoic rooms by ISO 9614 standard.
Therefore, these values can be increased owing to ambient conditions during operation.
- Performances are based on the following conditions :
 - *Cooling : Indoor Ambient Temp. 27°CDB / 19°CWB, Outdoor Ambient Temp. 35°CDB / 24°CWB
 - *Heating : Indoor Ambient Temp. 20°CDB / 15°CWB, Outdoor Ambient Temp. 7°CDB / 6°CWB
 - Interconnected Pipe Length is 7.5m and difference of Elevation (Outdoor ~ Indoor Unit) is 0m.
- EUROVENT Test Condition :
 - Performance values in this PDB are based on Ceiling mounted cassette combination.
 - Refer to EUROVENT web site(www.eurovent-certification.com) for other indoor unit combination and more detail test conditions.
- The maximum combination ratio is 160%.
- This product contains Fluorinated greenhouse gases.
- * : In case of ARUN050GSL0, maximum combination ratio is 130%.

3. Dimensions

3.1 Dimensional Drawings

ARUN040GSS0 / ARUN050GSL0

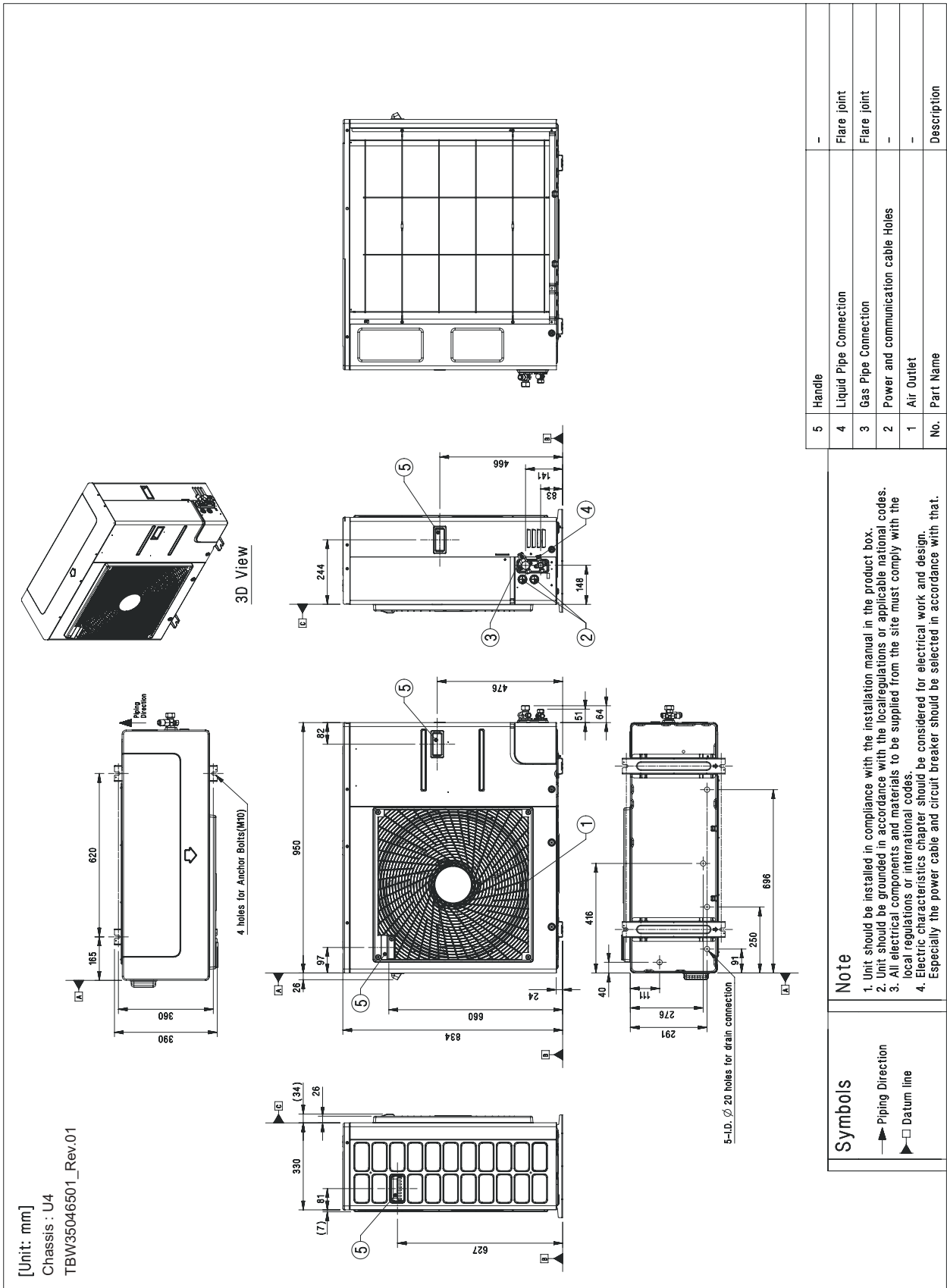

3. Dimensions

ARUN050GSS0 / ARUN060GSS0

ARUN040LSS0 / ARUN050LSS0 / ARUN060LSS0 / ARUN080LSS0

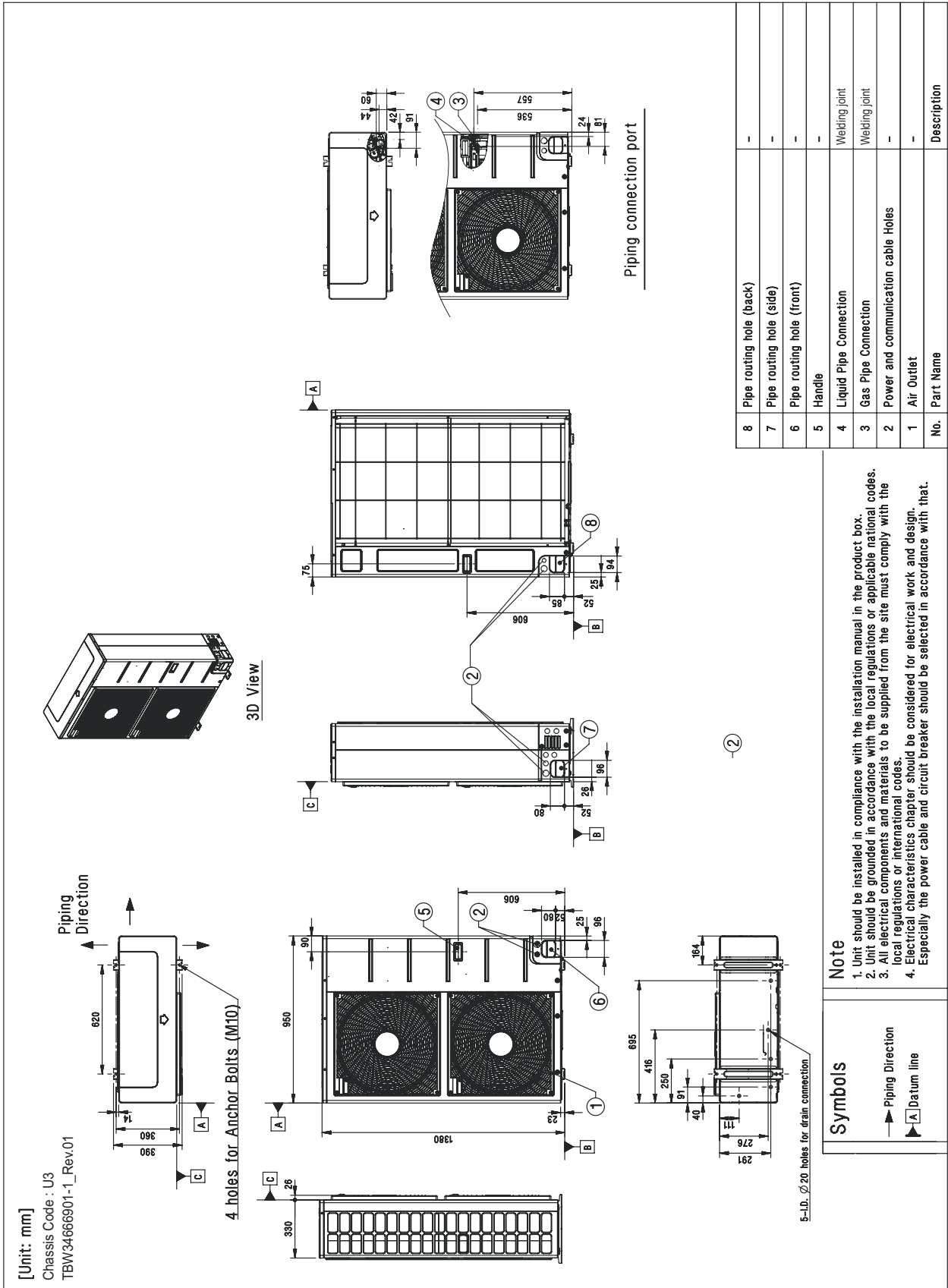

Note

- Unit should be installed in compliance with the installation manual in the product box.
- Unit should be grounded in accordance with the local regulations or applicable national codes.
- All electrical components and materials to be supplied from the site must comply with the local regulations or international codes.
- Electrical characteristics chapter should be considered for electrical work and design. Especially the power cable and circuit breaker should be selected in accordance with that.

Symbols

- Piping Direction
- A Datum line

3. Dimensions

ARUN100LSS0 / ARUN120LSS0

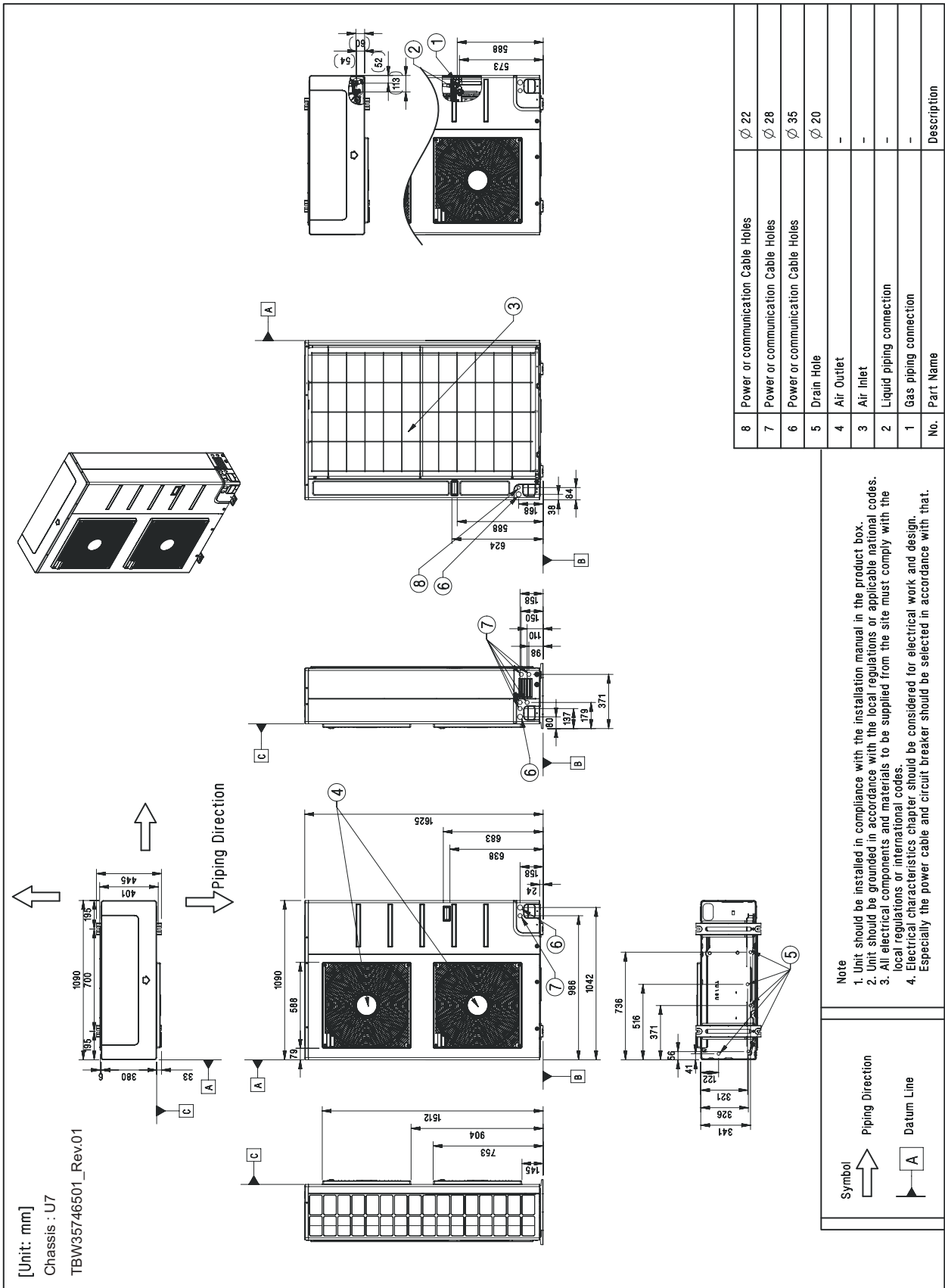

3. Dimensions

3.2 Center of Gravity

ARUN040GSS0 / ARUN050GSL0

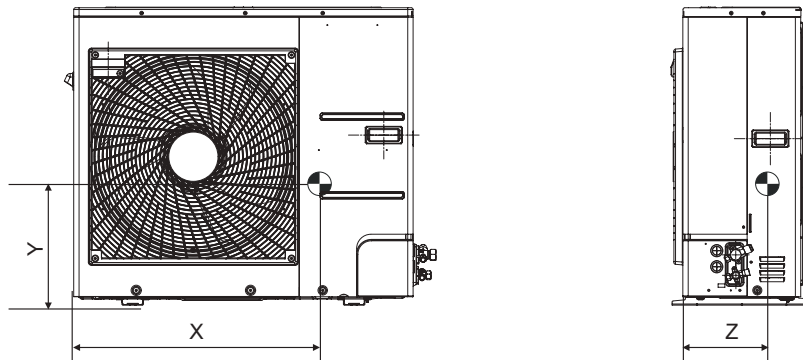

Model Name	X [mm]	Y [mm]	Z [mm]
ARUN040GSS0 ARUN050GSL0	740	340	170

ARUN050GSS0 / ARUN060GSS0

ARUN040LSS0 / ARUN050LSS0 / ARUN060LSS0 / ARUN080LSS0

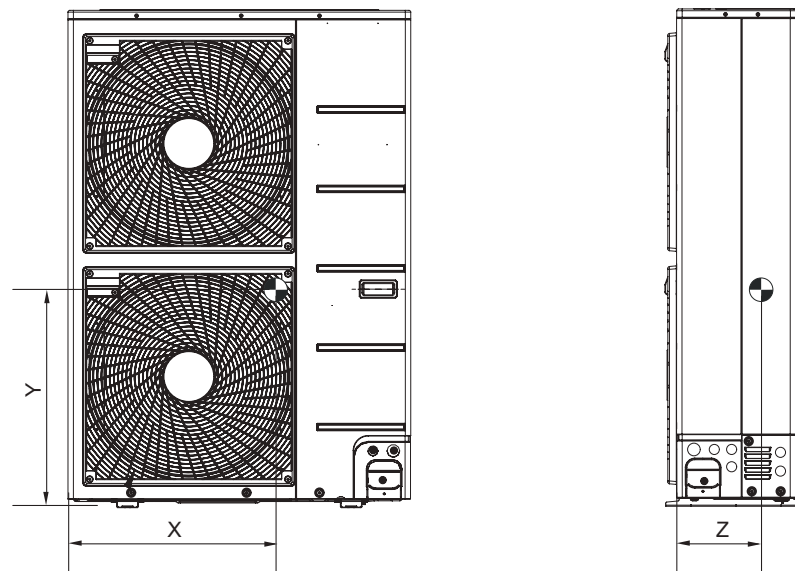

Model Name	X [mm]	Y [mm]	Z [mm]
ARUN050GSS0 ARUN060GSS0 ARUN040LSS0 ARUN050LSS0 ARUN060LSS0 ARUN080LSS0	440	657	233

3. Dimensions

ARUN100LSS0 / ARUN120LSS0

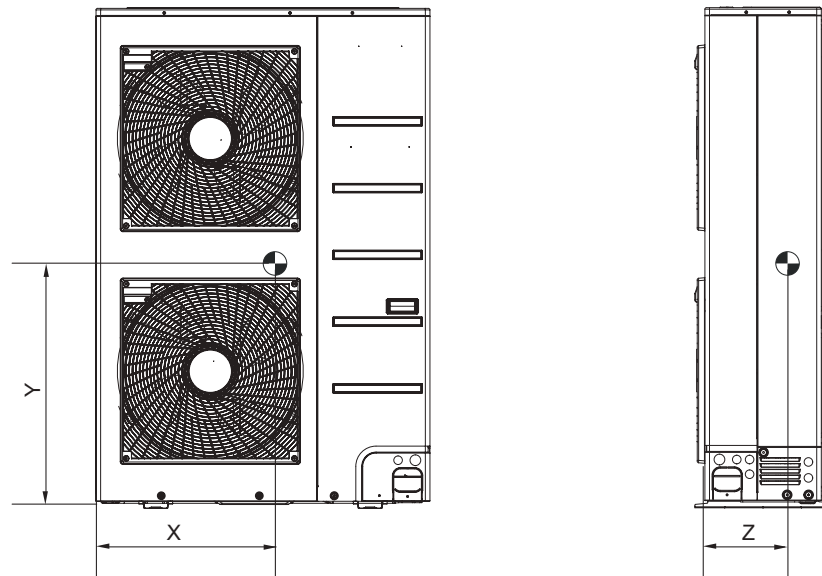

Model Name	X [mm]	Y [mm]	Z [mm]
ARUN100LSS0 ARUN120LSS0	522	750	256

4. Electric Characteristics

■ Wiring of Main Power Supply and Equipment Capacity

1. Use a separate power supply for the Outdoor Unit and Indoor Unit.
2. Bear in mind ambient conditions (ambient temperature, direct sunlight, rain liquid, etc.) when proceeding with the wiring and connections
3. The wire size is the minimum value for metal conduit wiring. The power cord size should be 1 rank thicker taking into account the line voltage drops. Make sure the power-supply voltage does not drop more than 10%.
4. Specific wiring requirements should adhere to the wiring regulations of the region.
5. Power supply cords of parts of appliances for outdoor use should not be lighter than polychloroprene sheathed flexible cord (design 60245 IEC57).
6. Don't install an individual switch or electrical outlet to disconnect each of indoor unit separately from the power supply.

WARNING

- Follow ordinance of local regulation for technical standard related to electrical equipment, wiring regulations and guidance of each electric power company.
- Make sure to use specified wires for connections so that no external force is imparted to terminal connections. If connections are not fixed firmly, it may cause heating or fire.
- Make sure to use the appropriate type of overcurrent protection switch. Note that generated overcurrent may include some amount of direct current.
- All Installation site must require attachment of an earth leakage breaker. If no earth leakage breaker is installed, it may cause an electric shock.

CAUTION

- Do not use anything other than breaker and fuse with correct capacity. Using fuse and wire or copper wire with too large capacity may cause a malfunction of unit or fire.
-

4. Electric Characteristics

4.1 1 Phase / Heat Pump

■ 50Hz

Model	Unit			Power Supply			COMP			OFM	
	Hz	Volts	Voltage-range	MCA	TOCA	MFA	MSC	RLA(Cooling)	RLA(Heating)	kW	FLA
4 HP	50	220-240	Min.:198, Max.:264	25.0	26.0	30	-	17.8	13.5	0.12	1.0
5 HP (1Fan)	50	220-240	Min.:198, Max.:264	27.5	26.0	30	-	24.0	17.6	0.12	1.0
5 HP (2Fan)	50	220-240	Min.:198, Max.:264	27.5	26.0	30	-	20.5	18.5	0.35	1.0
6 HP	50	220-240	Min.:198, Max.:264	29.4	26.0	40	-	23.2	22.4	0.35	1.0

■ 60Hz

Model	Unit			Power Supply			COMP			OFM	
	Hz	Volts	Voltage-range	MCA	TOCA	MFA	MSC	RLA(Cooling)	RLA(Heating)	kW	FLA
4 HP	60	220	Min.:198, Max.:242	25.0	26.0	30	-	17.8	13.5	0.12	1.0
5 HP (1Fan)	60	220	Min.:198, Max.:242	27.5	26.0	30	-	24.0	17.6	0.12	1.0
5 HP (2Fan)	60	220	Min.:198, Max.:242	27.5	26.0	30	-	20.5	18.5	0.35	1.0
6 HP	60	220	Min.:198, Max.:242	29.4	26.0	40	-	23.2	22.4	0.35	1.0

Note

- Voltage supplied to the unit terminals should be within the minimum and maximum range.
- Maximum allowable voltage unbalance between phase is 2%.
- MSC means the Max. current during the starting of compressor.
- MSC and RLA are measured as the compressor only test condition.
- OFM are measured as the outdoor unit test condition.
- TOCA means the total over current value of each outdoor unit.
- Select the wire size based on the larger value among MCA or TOCA.
- MFA is recommended fuse amps.
- TOCA is minimum required amperes for selecting the circuit breaker and ground fault circuit interrupter. Please select the circuit breaker size equal or greater than TOCA. All installation site must require attachment of an earth leakage breaker.[Circuit breaker type is ELCB (Earth Leakage Circuit Breaker)].
- Select the electrical equipment of combination unit according to the electrical characteristics of individual unit.

Symbols

- MCA** : Minimum Circuit Amperes (A)
TOCA : Total Over Current Amperes (A)
MFA : Maximum Fuse Amperes (A)
MSC : Maximum Starting Current (A)
RLA : Rated Load Amperes (A)
OFM : Outdoor Fan Motor
kW : Fan Motor rated output (kW)
FLA : Full Load Amperes (A)

4. Electric Characteristics

4.2 3 Phase / Heat Pump

■ 50Hz

Model	Unit			Power Supply			COMP			OFM	
	Hz	Volts	Voltage-range	MCA	TOCA	MFA	MSC	RLA(Cooling)	RLA(Heating)	kW	FLA
4 HP	50	380-415	Min.:342, Max.:456	12.5	17.0	20	-	4.3	3.3	0.35	1.0
5 HP	50	380-415	Min.:342, Max.:456	14.4	17.0	20	-	6.1	5.5	0.35	1.0
6 HP	50	380-415	Min.:342, Max.:456	16.1	17.0	20	-	7.0	6.8	0.35	1.0
8 HP	50	380-415	Min.:342, Max.:456	21.3	24.0	30	4.0	12.1	9.8	0.35	1.0
10 HP	50	380-415	Min.:342, Max.:456	26.3	35.0	30	4.5	16.5	10.4	0.50	2.8
12 HP	50	380-415	Min.:342, Max.:456	32.5	35.0	35	4.5	20.9	16.2	0.50	2.8

■ 60Hz

Model	Unit			Power Supply			COMP			OFM	
	Hz	Volts	Voltage-range	MCA	TOCA	MFA	MSC	RLA(Cooling)	RLA(Heating)	kW	FLA
4 HP	60	380	Min.:342, Max.:418	12.5	17.0	20	-	4.3	3.3	0.35	1.0
5 HP	60	380	Min.:342, Max.:418	14.4	17.0	20	-	6.1	5.5	0.35	1.0
6 HP	60	380	Min.:342, Max.:418	16.1	17.0	20	-	7.0	6.8	0.35	1.0
8 HP	60	380	Min.:342, Max.:418	21.3	24.0	30	4.0	12.1	9.8	0.35	1.0
10 HP	60	380	Min.:342, Max.:418	26.3	35.0	30	4.5	16.5	10.4	0.50	2.8
12 HP	60	380	Min.:342, Max.:418	32.5	35.0	35	4.5	20.9	16.2	0.50	2.8

Note

- Voltage supplied to the unit terminals should be within the minimum and maximum range.
- Maximum allowable voltage unbalance between phase is 2%.
- MSC means the Max. current during the starting of compressor.
- MSC and RLA are measured as the compressor only test condition.
- OFM are measured as the outdoor unit test condition.
- TOCA means the total over current value of each outdoor unit.
- Select the wire size based on the larger value among MCA or TOCA.
- MFA is recommended fuse amps.
- TOCA is minimum required amperes for selecting the circuit breaker and ground fault circuit interrupter. Please select the circuit breaker size equal or greater than TOCA. All installation site must require attachment of an earth leakage breaker.[Circuit breaker type is ELCB (Earth Leakage Circuit Breaker)].
- Select the electrical equipment of combination unit according to the electrical characteristics of individual unit.

Symbols

- MCA** : Minimum Circuit Amperes (A)
TOCA : Total Over Current Amperes (A)
MFA : Maximum Fuse Amperes (A)
MSC : Maximum Starting Current (A)
RLA : Rated Load Amperes (A)
OFM : Outdoor Fan Motor
kW : Fan Motor rated output (kW)
FLA : Full Load Amperes (A)

5. Indoor Unit and Outdoor Unit Capacity Index

5.1 Outdoor Unit Selection

See the indoor unit capacity tables for given Indoor and Outdoor temperature.

Select the unit whose capacity is the nearest to or greater than given load.

Note

Individual Indoor Unit capacity is subject to change by combination. Actual capacity has to be calculated according to the combination by using Outdoor unit capacity table.

5.2 Outdoor Unit Selection

Allowable combinations are indicated below. In general, outdoor unit can be selected depending on the location of the unit, zoning and usage of the rooms.

The indoor and outdoor unit combination is determined by comparing the sum of indoor unit capacity index with each Outdoor Unit. It is recommended to be the nearest to 100% combination ratio or to be smaller than that. Refer the table below. To manage cooling/heating load properly, it's better to be selected the bigger capacity outdoor unit rather than the nearest, if the installation space is large enough.

■ Combination Ratio

Line up	Outdoor Unit Type	Number of Outdoor Units	Total Combination ratio
Multi V 5	Heat Pump & Heat recovery	Single Unit	50 ~ 130 % (200%)
		Two Units	50 ~ 130 % (160%)
		Three or Four Units	50 ~ 130 %
Multi V S	R410A Heat Pump R410A Heat Recovery R32 Heat Pump	Single Unit	50 ~ 130 % (160%)
Multi V Water IV	Heat Pump Heat Recovery	Single Unit	50 ~ 130 % (200%)
		Two Units	50 ~ 130 % (160%)
		Three or Four Units	50 ~ 130 %
Multi V M	Multi V M	Single Unit	50 ~ 130 %

Note

1. The combination ratio is defined as the sum of indoor unit nominal capacity (kW) divided by the outdoor rated cooling capacity (kW).
2. LG guarantees the operation only within a maximum combination ratio of 130%.
3. If the client wants to go beyond 130%, please contact the local subsidiary and discuss the requirements. Please be aware that going over 130% may result in poor performance. If the total operating ratio of indoor unit exceeds 130%, the indoor unit is operated in low fan speed mode.
4. In case of 1:1 installation (i.e. one outdoor unit with one indoor unit), combination ratio cannot be exceed 105%.
5. For systems where special indoor units are involved, please refer to "Table. Combination Ratio for System with Special Indoor Units" in indoor unit PDB

◆ INDOOR UNIT CAPACITY INDEX

Unit Capacity (Btu/h)	5k	7k	9k	12k	15k	18k	21k	24k	28k	36k	42k	48k	54k	76k	96k
Capacity Index	1.6	2.2	2.8	3.6	4.5	5.6	6.2	7.1	8.2	10.6	12.3	14.1	15.8	22.4	28.0

* Capacity Index is same as the capacity(kW).

* 6HP or less outdoor units can be connected to indoor units below 76kBtu/h.

6. Capacity Tables

6.1 Cooling Capacity

6.1.1 1 Phase / Heat Pump

◆ ARUN040GSS0

Combination (%)	Outdoor Air Temp. (°C DB)	Indoor Air Temp. (DB/WB, °C)													
		20		23		26		27		28		30		32	
		14	16	18	19	20	22	24	TC	PI	TC	PI	TC	PI	
130	10	11.1	1.71	13.2	2.09	15.3	2.42	15.9	2.47	16.1	2.50	16.5	2.51	16.9	2.53
	12	11.1	1.75	13.2	2.16	15.3	2.52	15.6	2.54	15.9	2.59	16.2	2.61	16.6	2.63
	14	11.1	1.81	13.2	2.24	15.2	2.62	15.5	2.64	15.6	2.68	16.1	2.71	16.5	2.73
	16	11.1	1.88	13.2	2.32	15.1	2.74	15.2	2.76	15.4	2.78	15.8	2.81	16.2	2.83
	18	11.1	1.96	13.2	2.45	14.8	2.88	15.0	2.91	15.2	2.92	15.6	2.94	16.1	2.96
	20	11.1	2.04	13.2	2.62	14.6	3.02	14.9	3.05	15.0	3.07	15.4	3.08	15.8	3.10
	21	11.1	2.10	13.2	2.71	14.5	3.09	14.7	3.12	14.9	3.14	15.3	3.15	15.7	3.17
	23	11.1	2.25	13.2	2.91	14.3	3.22	14.5	3.25	14.7	3.28	15.1	3.30	15.5	3.32
	25	11.1	2.40	13.2	3.10	14.1	3.37	14.4	3.40	14.5	3.42	14.9	3.44	15.3	3.46
	27	11.1	2.57	13.2	3.32	13.9	3.51	14.1	3.54	14.4	3.56	14.7	3.58	15.1	3.60
	29	11.1	2.74	13.2	3.55	13.7	3.66	13.9	3.68	14.1	3.71	14.5	3.73	14.9	3.75
	31	11.1	2.92	13.1	3.74	13.5	3.80	13.7	3.83	13.9	3.85	14.3	3.87	14.7	3.89
	33	11.1	3.11	12.9	3.88	13.3	3.95	13.5	3.97	13.7	3.99	14.1	4.01	14.5	4.04
	35	11.1	3.32	12.7	4.02	13.1	4.09	13.3	4.12	13.5	4.14	13.9	4.16	14.3	4.18
37	11.1	3.44	12.5	4.10	12.9	4.17	13.1	4.21	13.3	4.22	13.7	4.24	14.1	4.27	
39	11.1	3.55	12.3	4.18	12.7	4.26	12.9	4.29	13.1	4.30	13.5	4.32	13.9	4.35	
120	10	10.2	1.54	12.2	1.89	14.1	2.24	15.1	2.42	15.9	2.46	16.2	2.47	16.6	2.48
	12	10.2	1.58	12.2	1.95	14.1	2.33	15.1	2.47	15.6	2.55	16.0	2.58	16.4	2.59
	14	10.2	1.63	12.2	2.02	14.1	2.43	15.1	2.57	15.4	2.64	15.8	2.68	16.2	2.71
	16	10.2	1.69	12.2	2.10	14.1	2.52	15.0	2.70	15.2	2.77	15.6	2.78	16.0	2.81
	18	10.2	1.76	12.2	2.19	14.1	2.67	14.8	2.86	15.0	2.91	15.4	2.92	15.8	2.93
	20	10.2	1.83	12.2	2.32	14.1	2.85	14.6	3.02	14.8	3.05	15.2	3.06	15.5	3.08
	21	10.2	1.88	12.2	2.41	14.1	2.95	14.5	3.09	14.7	3.12	15.1	3.13	15.5	3.15
	23	10.2	2.01	12.2	2.58	14.1	3.14	14.3	3.23	14.5	3.26	14.9	3.28	15.2	3.29
	25	10.2	2.15	12.2	2.76	13.9	3.31	14.1	3.37	14.3	3.41	14.7	3.42	15.0	3.43
	27	10.2	2.29	12.2	2.95	13.7	3.48	13.9	3.51	14.1	3.55	14.5	3.56	14.8	3.58
	29	10.2	2.45	12.2	3.15	13.5	3.63	13.7	3.66	13.9	3.69	14.2	3.70	14.6	3.72
	31	10.2	2.61	12.2	3.36	13.3	3.78	13.5	3.79	13.7	3.83	14.1	3.85	14.4	3.86
	33	10.2	2.78	12.2	3.59	13.1	3.92	13.3	3.94	13.5	3.97	13.8	3.99	14.2	4.00
	35	10.2	2.95	12.2	3.82	12.9	4.07	13.1	4.08	13.3	4.11	13.7	4.13	14.0	4.15
37	10.2	3.08	12.2	3.92	12.7	4.14	12.9	4.16	13.1	4.18	13.4	4.21	13.8	4.22	
39	10.2	3.21	12.1	4.01	12.5	4.21	12.7	4.24	12.8	4.25	13.3	4.28	13.6	4.29	
110	10	9.4	1.38	11.2	1.69	13.0	2.00	13.9	2.17	14.8	2.33	15.9	2.43	16.2	2.44
	12	9.4	1.43	11.2	1.74	13.0	2.09	13.9	2.23	14.8	2.42	15.7	2.52	16.0	2.56
	14	9.4	1.47	11.2	1.82	13.0	2.18	13.9	2.34	14.8	2.54	15.5	2.61	15.8	2.67
	16	9.4	1.52	11.2	1.89	13.0	2.27	13.9	2.44	14.8	2.70	15.3	2.76	15.6	2.78
	18	9.4	1.58	11.2	1.97	13.0	2.40	13.9	2.60	14.8	2.86	15.1	2.90	15.4	2.91
	20	9.4	1.64	11.2	2.06	13.0	2.55	13.9	2.77	14.5	3.01	14.9	3.04	15.2	3.06
	21	9.4	1.67	11.2	2.13	13.0	2.64	13.9	2.87	14.4	3.08	14.8	3.12	15.1	3.13
	23	9.4	1.78	11.2	2.28	13.0	2.83	13.9	3.05	14.2	3.23	14.6	3.26	14.9	3.27
	25	9.4	1.90	11.2	2.43	13.0	3.03	13.9	3.23	14.0	3.36	14.4	3.40	14.7	3.41
	27	9.4	2.03	11.2	2.60	13.0	3.24	13.6	3.41	13.8	3.52	14.2	3.54	14.5	3.55
	29	9.4	2.17	11.2	2.78	13.0	3.46	13.5	3.55	13.6	3.66	14.0	3.68	14.3	3.70
	31	9.4	2.31	11.2	2.96	13.0	3.69	13.2	3.71	13.4	3.81	13.8	3.82	14.1	3.84
	33	9.4	2.46	11.2	3.15	12.9	3.90	13.1	3.87	13.2	3.95	13.5	3.96	13.9	3.98
	35	9.4	2.62	11.2	3.36	12.6	4.04	12.8	4.05	13.0	4.09	13.3	4.11	13.7	4.12
37	9.4	2.72	11.2	3.47	12.5	4.11	12.6	4.12	12.8	4.15	13.1	4.18	13.5	4.19	
39	9.4	2.82	11.2	3.57	12.2	4.17	12.4	4.18	12.6	4.21	12.9	4.24	13.3	4.25	

6. Capacity Tables

Combination (%)	Outdoor Air Temp. (°C DB)	Indoor Air Temp. (DB/WB, °C)													
		20		23		26		27		28		30		32	
		14		16		18		19		20		22		24	
		TC	PI	TC	PI	TC	PI	TC	PI	TC	PI	TC	PI	TC	PI
100	10	8.2	1.25	9.7	1.51	11.3	1.80	12.1	1.94	12.9	2.09	14.5	2.32	15.9	2.34
	12	8.2	1.29	9.7	1.58	11.3	1.86	12.1	1.99	12.9	2.15	14.5	2.45	15.7	2.47
	14	8.2	1.33	9.7	1.64	11.3	1.94	12.1	2.08	12.9	2.24	14.5	2.58	15.5	2.61
	16	8.2	1.37	9.7	1.69	11.3	2.02	12.1	2.18	12.9	2.37	14.5	2.71	15.3	2.75
	18	8.2	1.41	9.7	1.76	11.3	2.10	12.1	2.28	12.9	2.51	14.5	2.86	15.1	2.88
	20	8.2	1.46	9.7	1.82	11.3	2.22	12.1	2.45	12.9	2.68	14.5	3.00	14.9	3.02
	21	8.2	1.49	9.7	1.87	11.3	2.29	12.1	2.53	12.9	2.78	14.5	3.07	14.8	3.09
	23	8.2	1.58	9.7	2.00	11.3	2.46	12.1	2.71	12.9	2.98	14.3	3.21	14.6	3.24
	25	8.2	1.67	9.7	2.13	11.3	2.63	12.1	2.91	12.9	3.19	14.1	3.35	14.3	3.37
	27	8.2	1.79	9.7	2.27	11.3	2.81	12.1	3.10	12.9	3.39	13.9	3.51	14.2	3.53
	29	8.2	1.90	9.7	2.42	11.3	3.01	12.1	3.32	12.9	3.59	13.7	3.65	14.0	3.68
	31	8.2	2.03	9.7	2.58	11.3	3.20	12.1	3.54	12.9	3.77	13.4	3.79	13.7	3.82
	33	8.2	2.16	9.7	2.75	11.3	3.42	12.1	3.78	12.9	3.91	13.2	3.93	13.5	3.96
	35	8.2	2.29	9.7	2.93	11.3	3.64	12.1	4.03	12.7	4.05	13.0	4.07	13.3	4.10
37	8.2	2.39	9.7	3.05	11.3	3.74	12.1	4.10	12.5	4.12	12.8	4.14	13.1	4.17	
39	8.2	2.48	9.7	3.17	11.3	3.84	12.1	4.17	12.3	4.18	12.6	4.20	12.9	4.24	
90	10	7.3	1.25	8.8	1.51	10.2	1.80	10.9	1.94	11.6	2.09	13.0	2.32	14.4	2.34
	12	7.3	1.29	8.8	1.58	10.2	1.86	10.9	1.99	11.6	2.15	13.0	2.45	14.4	2.47
	14	7.3	1.33	8.8	1.64	10.2	1.94	10.9	2.08	11.6	2.24	13.0	2.58	14.4	2.61
	16	7.3	1.37	8.8	1.69	10.2	2.02	10.9	2.18	11.6	2.37	13.0	2.71	14.4	2.75
	18	7.3	1.41	8.8	1.76	10.2	2.10	10.9	2.28	11.6	2.49	13.0	2.79	14.4	2.88
	20	7.3	1.46	8.8	1.82	10.2	2.18	10.9	2.37	11.6	2.59	13.0	2.99	14.4	3.02
	21	7.3	1.49	8.8	1.87	10.2	2.23	10.9	2.44	11.6	2.68	13.0	3.07	14.4	3.09
	23	7.3	1.57	8.8	1.94	10.2	2.38	10.9	2.62	11.6	2.87	13.0	3.21	14.2	3.24
	25	7.3	1.65	8.8	2.07	10.2	2.55	10.9	2.80	11.6	3.07	13.0	3.35	14.0	3.37
	27	7.3	1.76	8.8	2.21	10.2	2.72	10.9	2.99	11.6	3.29	13.0	3.51	13.8	3.53
	29	7.3	1.87	8.8	2.36	10.2	2.91	10.9	3.20	11.6	3.51	13.0	3.65	13.6	3.68
	31	7.3	1.99	8.8	2.51	10.2	3.10	10.9	3.41	11.6	3.74	13.0	3.79	13.4	3.82
	33	7.3	2.12	8.8	2.67	10.2	3.30	10.9	3.63	11.6	3.91	13.0	3.93	13.2	3.96
	35	7.3	2.24	8.8	2.84	10.2	3.51	10.9	3.87	11.6	4.05	12.8	4.07	13.0	4.10
37	7.3	2.38	8.8	3.02	10.2	3.74	10.9	4.10	11.6	4.12	12.6	4.14	12.8	4.17	
39	7.3	2.48	8.8	3.17	10.2	3.84	10.9	4.17	11.6	4.18	12.4	4.20	12.6	4.24	
80	10	6.5	1.24	7.8	1.49	9.0	1.75	9.7	1.89	10.3	2.02	11.6	2.31	12.8	2.34
	12	6.5	1.27	7.8	1.51	9.0	1.78	9.7	1.92	10.3	2.06	11.6	2.35	12.8	2.47
	14	6.5	1.28	7.8	1.54	9.0	1.81	9.7	1.95	10.3	2.09	11.6	2.39	12.8	2.60
	16	6.5	1.30	7.8	1.57	9.0	1.84	9.7	1.99	10.3	2.14	11.6	2.45	12.8	2.65
	18	6.5	1.33	7.8	1.59	9.0	1.88	9.7	2.02	10.3	2.18	11.6	2.49	12.8	2.71
	20	6.5	1.35	7.8	1.63	9.0	1.92	9.7	2.07	10.3	2.22	11.6	2.58	12.8	2.90
	21	6.5	1.36	7.8	1.64	9.0	1.94	9.7	2.09	10.3	2.27	11.6	2.66	12.8	3.01
	23	6.5	1.39	7.8	1.67	9.0	2.02	9.7	2.22	10.3	2.43	11.6	2.81	12.8	3.22
	25	6.5	1.44	7.8	1.78	9.0	2.17	9.7	2.38	10.3	2.60	11.6	3.01	12.8	3.37
	27	6.5	1.52	7.8	1.89	9.0	2.32	9.7	2.54	10.3	2.77	11.6	3.20	12.8	3.53
	29	6.5	1.62	7.8	2.02	9.0	2.46	9.7	2.70	10.3	2.96	11.6	3.43	12.8	3.68
	31	6.5	1.72	7.8	2.14	9.0	2.63	9.7	2.88	10.3	3.15	11.6	3.64	12.8	3.82
	33	6.5	1.83	7.8	2.29	9.0	2.80	9.7	3.07	10.3	3.36	11.6	3.83	12.8	3.96
	35	6.5	1.94	7.8	2.43	9.0	2.98	9.7	3.27	10.3	3.58	11.6	4.06	12.7	4.10
37	6.5	2.05	7.8	2.58	9.0	3.16	9.7	3.48	10.3	3.81	11.6	4.14	12.5	4.17	
39	6.5	2.17	7.8	2.73	9.0	3.35	9.7	3.67	10.3	4.05	11.6	4.20	12.3	4.24	
70	10	5.7	1.04	6.8	1.23	7.9	1.43	8.5	1.54	9.0	1.65	10.1	1.88	11.2	2.10
	12	5.7	1.05	6.8	1.25	7.9	1.46	8.5	1.57	9.0	1.68	10.1	1.91	11.2	2.14
	14	5.7	1.07	6.8	1.27	7.9	1.49	8.5	1.59	9.0	1.71	10.1	1.95	11.2	2.18
	16	5.7	1.09	6.8	1.29	7.9	1.51	8.5	1.62	9.0	1.74	10.1	1.98	11.2	2.23
	18	5.7	1.10	6.8	1.31	7.9	1.54	8.5	1.66	9.0	1.77	10.1	2.02	11.2	2.27
	20	5.7	1.12	6.8	1.34	7.9	1.57	8.5	1.69	9.0	1.81	10.1	2.07	11.2	2.35
	21	5.7	1.13	6.8	1.35	7.9	1.58	8.5	1.71	9.0	1.83	10.1	2.10	11.2	2.43
	23	5.7	1.15	6.8	1.38	7.9	1.62	8.5	1.76	9.0	1.92	10.1	2.25	11.2	2.56
	25	5.7	1.17	6.8	1.43	7.9	1.72	8.5	1.89	9.0	2.05	10.1	2.40	11.2	2.74
	27	5.7	1.23	6.8	1.53	7.9	1.84	8.5	2.00	9.0	2.19	10.1	2.56	11.2	2.91
	29	5.7	1.31	6.8	1.62	7.9	1.95	8.5	2.13	9.0	2.33	10.1	2.74	11.2	3.12
	31	5.7	1.40	6.8	1.72	7.9	2.08	8.5	2.28	9.0	2.48	10.1	2.91	11.2	3.31
	33	5.7	1.48	6.8	1.82	7.9	2.21	8.5	2.42	9.0	2.64	10.1	3.10	11.2	3.49
	35	5.7	1.56	6.8	1.94	7.9	2.35	8.5	2.57	9.0	2.81	10.1	3.31	11.2	3.70
37	5.7	1.66	6.8	2.06	7.9	2.50	8.5	2.74	9.0	2.99	10.1	3.52	11.2	3.90	
39	5.7	1.74	6.8	2.17	7.9	2.65	8.5	2.89	9.0	3.16	10.1	3.73	11.2	4.08	

6. Capacity Tables

Combination (%)	Outdoor Air Temp. (°C DB)	Indoor Air Temp. (DB/WB, °C)													
		20		23		26		27		28		30		32	
		14		16		18		19		20		22		24	
		TC	PI	TC	PI	TC	PI	TC	PI	TC	PI	TC	PI	TC	PI
60	10	4.9	0.85	5.8	1.00	6.8	1.16	7.3	1.24	7.7	1.32	8.7	1.50	9.6	1.68
	12	4.9	0.86	5.8	1.01	6.8	1.17	7.3	1.26	7.7	1.34	8.7	1.52	9.6	1.71
	14	4.9	0.87	5.8	1.03	6.8	1.20	7.3	1.28	7.7	1.37	8.7	1.55	9.6	1.74
	16	4.9	0.89	5.8	1.05	6.8	1.21	7.3	1.30	7.7	1.40	8.7	1.58	9.6	1.77
	18	4.9	0.90	5.8	1.07	6.8	1.24	7.3	1.33	7.7	1.42	8.7	1.61	9.6	1.81
	20	4.9	0.92	5.8	1.08	6.8	1.26	7.3	1.35	7.7	1.44	8.7	1.64	9.6	1.85
	21	4.9	0.93	5.8	1.09	6.8	1.27	7.3	1.37	7.7	1.46	8.7	1.66	9.6	1.86
	23	4.9	0.94	5.8	1.11	6.8	1.29	7.3	1.39	7.7	1.49	8.7	1.72	9.6	1.98
	25	4.9	0.96	5.8	1.13	6.8	1.34	7.3	1.46	7.7	1.58	8.7	1.84	9.6	2.12
	27	4.9	0.99	5.8	1.20	6.8	1.43	7.3	1.55	7.7	1.68	8.7	1.95	9.6	2.25
	29	4.9	1.05	5.8	1.27	6.8	1.52	7.3	1.65	7.7	1.79	8.7	2.08	9.6	2.41
	31	4.9	1.11	5.8	1.35	6.8	1.61	7.3	1.76	7.7	1.91	8.7	2.22	9.6	2.56
	33	4.9	1.17	5.8	1.43	6.8	1.71	7.3	1.87	7.7	2.03	8.7	2.36	9.6	2.73
	35	4.9	1.24	5.8	1.52	6.8	1.82	7.3	1.98	7.7	2.15	8.7	2.52	9.6	2.90
	37	4.9	1.31	5.8	1.61	6.8	1.93	7.3	2.11	7.7	2.29	8.7	2.67	9.6	3.09
39	4.9	1.38	5.8	1.69	6.8	2.04	7.3	2.24	7.7	2.41	8.7	2.84	9.6	3.28	
50	10	4.1	0.69	4.9	0.80	5.7	0.91	6.1	0.98	6.4	1.03	7.2	1.16	8.0	1.30
	12	4.1	0.70	4.9	0.81	5.7	0.92	6.1	0.99	6.4	1.06	7.2	1.19	8.0	1.32
	14	4.1	0.71	4.9	0.82	5.7	0.94	6.1	1.00	6.4	1.07	7.2	1.20	8.0	1.34
	16	4.1	0.72	4.9	0.84	5.7	0.95	6.1	1.03	6.4	1.08	7.2	1.22	8.0	1.36
	18	4.1	0.73	4.9	0.84	5.7	0.97	6.1	1.04	6.4	1.11	7.2	1.24	8.0	1.39
	20	4.1	0.73	4.9	0.86	5.7	0.99	6.1	1.06	6.4	1.13	7.2	1.27	8.0	1.42
	21	4.1	0.74	4.9	0.87	5.7	1.00	6.1	1.07	6.4	1.14	7.2	1.28	8.0	1.43
	23	4.1	0.76	4.9	0.88	5.7	1.01	6.1	1.08	6.4	1.16	7.2	1.30	8.0	1.46
	25	4.1	0.76	4.9	0.90	5.7	1.03	6.1	1.11	6.4	1.19	7.2	1.37	8.0	1.56
	27	4.1	0.78	4.9	0.92	5.7	1.09	6.1	1.18	6.4	1.27	7.2	1.46	8.0	1.67
	29	4.1	0.82	4.9	0.98	5.7	1.16	6.1	1.25	6.4	1.35	7.2	1.55	8.0	1.77
	31	4.1	0.87	4.9	1.04	5.7	1.23	6.1	1.32	6.4	1.43	7.2	1.65	8.0	1.88
	33	4.1	0.92	4.9	1.10	5.7	1.30	6.1	1.40	6.4	1.52	7.2	1.75	8.0	2.01
	35	4.1	0.97	4.9	1.16	5.7	1.38	6.1	1.49	6.4	1.61	7.2	1.86	8.0	2.13
	37	4.1	1.03	4.9	1.23	5.7	1.46	6.1	1.58	6.4	1.70	7.2	1.98	8.0	2.26
39	4.1	1.07	4.9	1.29	5.7	1.54	6.1	1.67	6.4	1.79	7.2	2.09	8.0	2.40	

Note

1. TC: Total Capacity(kW), PI : Power Input(kW, Comp. + Outdoor fan motor)
2. Capacity tables show the average value of conditions which may occur.

6. Capacity Tables

◆ ARUN050GSL0

Combination (%)	Outdoor Air Temp. (°C DB)	Indoor Air Temp. (DB/WB, °C)													
		20		23		26		27		28		30		32	
		14		16		18		19		20		22		24	
		TC	PI	TC	PI	TC	PI	TC	PI	TC	PI	TC	PI	TC	PI
130	10	12.8	2.27	15.2	2.77	17.7	3.21	18.4	3.28	18.6	3.31	19.0	3.33	19.5	3.35
	12	12.8	2.32	15.2	2.87	17.7	3.34	18.1	3.37	18.4	3.43	18.8	3.46	19.3	3.48
	14	12.8	2.40	15.2	2.97	17.6	3.47	17.9	3.49	18.1	3.55	18.6	3.59	19.0	3.62
	16	12.8	2.49	15.2	3.07	17.4	3.62	17.6	3.66	17.8	3.68	18.3	3.72	18.8	3.75
	18	12.8	2.59	15.2	3.25	17.2	3.82	17.4	3.85	17.6	3.87	18.1	3.89	18.6	3.92
	20	12.8	2.71	15.2	3.47	16.9	4.00	17.2	4.04	17.4	4.06	17.8	4.08	18.3	4.11
	21	12.8	2.78	15.2	3.59	16.8	4.09	17.1	4.14	17.3	4.16	17.7	4.18	18.2	4.20
	23	12.8	2.98	15.2	3.85	16.6	4.27	16.8	4.31	17.1	4.35	17.5	4.37	18.0	4.39
	25	12.8	3.18	15.2	4.11	16.3	4.46	16.6	4.50	16.8	4.53	17.3	4.56	17.7	4.58
	27	12.8	3.40	15.2	4.40	16.1	4.65	16.3	4.69	16.6	4.72	17.1	4.75	17.5	4.78
	29	12.8	3.63	15.2	4.70	15.9	4.85	16.1	4.88	16.3	4.91	16.8	4.94	17.3	4.97
	31	12.8	3.87	15.2	4.95	15.6	5.04	15.9	5.07	16.1	5.10	16.5	5.13	17.0	5.16
	33	12.8	4.12	14.9	5.14	15.4	5.23	15.7	5.26	15.9	5.29	16.3	5.32	16.8	5.35
	35	12.8	4.40	14.7	5.33	15.1	5.42	15.4	5.46	15.7	5.48	16.1	5.51	16.5	5.54
37	12.8	4.55	14.5	5.43	14.9	5.53	15.1	5.57	15.4	5.59	15.8	5.61	16.3	5.65	
39	12.8	4.71	14.2	5.54	14.7	5.64	14.9	5.68	15.1	5.70	15.6	5.72	16.1	5.76	
120	10	11.8	2.04	14.1	2.50	16.4	2.97	17.5	3.21	18.4	3.26	18.8	3.27	19.2	3.29
	12	11.8	2.09	14.1	2.58	16.4	3.09	17.5	3.28	18.1	3.38	18.5	3.42	18.9	3.44
	14	11.8	2.17	14.1	2.67	16.4	3.21	17.5	3.40	17.8	3.50	18.3	3.56	18.7	3.59
	16	11.8	2.24	14.1	2.78	16.4	3.34	17.4	3.58	17.6	3.67	18.0	3.68	18.5	3.72
	18	11.8	2.33	14.1	2.91	16.4	3.54	17.2	3.78	17.4	3.85	17.8	3.87	18.3	3.89
	20	11.8	2.42	14.1	3.08	16.4	3.77	16.9	4.00	17.2	4.04	17.6	4.06	18.0	4.07
	21	11.8	2.49	14.1	3.19	16.4	3.91	16.8	4.09	17.0	4.14	17.5	4.15	17.9	4.17
	23	11.8	2.66	14.1	3.41	16.4	4.17	16.6	4.28	16.8	4.32	17.2	4.34	17.6	4.36
	25	11.8	2.85	14.1	3.66	16.1	4.39	16.3	4.47	16.5	4.51	17.0	4.53	17.4	4.55
	27	11.8	3.04	14.1	3.91	15.9	4.61	16.1	4.65	16.3	4.70	16.7	4.72	17.2	4.74
	29	11.8	3.24	14.1	4.17	15.6	4.81	15.9	4.84	16.1	4.89	16.5	4.91	16.9	4.93
	31	11.8	3.46	14.1	4.46	15.4	5.01	15.6	5.03	15.9	5.08	16.3	5.10	16.7	5.12
	33	11.8	3.68	14.1	4.75	15.2	5.19	15.4	5.22	15.6	5.26	16.0	5.29	16.4	5.31
	35	11.8	3.91	14.1	5.07	14.9	5.39	15.1	5.41	15.4	5.45	15.8	5.47	16.2	5.50
37	11.8	4.08	14.1	5.19	14.7	5.48	14.9	5.52	15.1	5.54	15.5	5.57	16.0	5.59	
39	11.8	4.26	14.0	5.31	14.4	5.58	14.7	5.62	14.9	5.63	15.3	5.67	15.7	5.68	
110	10	10.8	1.83	12.9	2.23	15.0	2.65	16.0	2.87	17.1	3.09	18.4	3.22	18.8	3.23
	12	10.8	1.89	12.9	2.31	15.0	2.76	16.0	2.95	17.1	3.21	18.2	3.34	18.5	3.39
	14	10.8	1.95	12.9	2.41	15.0	2.89	16.0	3.10	17.1	3.37	17.9	3.46	18.3	3.54
	16	10.8	2.02	12.9	2.50	15.0	3.01	16.0	3.24	17.1	3.57	17.7	3.66	18.1	3.68
	18	10.8	2.09	12.9	2.61	15.0	3.18	16.0	3.45	17.1	3.78	17.4	3.85	17.9	3.86
	20	10.8	2.17	12.9	2.74	15.0	3.37	16.0	3.68	16.8	3.99	17.2	4.03	17.6	4.05
	21	10.8	2.22	12.9	2.82	15.0	3.50	16.0	3.81	16.7	4.08	17.1	4.13	17.5	4.14
	23	10.8	2.36	12.9	3.02	15.0	3.75	16.0	4.04	16.5	4.28	16.9	4.32	17.2	4.33
	25	10.8	2.52	12.9	3.22	15.0	4.01	16.0	4.28	16.2	4.46	16.6	4.50	17.0	4.52
	27	10.8	2.70	12.9	3.45	15.0	4.30	15.8	4.51	16.0	4.67	16.4	4.69	16.8	4.71
	29	10.8	2.88	12.9	3.68	15.0	4.58	15.6	4.71	15.8	4.86	16.1	4.88	16.6	4.90
	31	10.8	3.06	12.9	3.92	15.0	4.89	15.3	4.91	15.5	5.04	15.9	5.07	16.3	5.09
	33	10.8	3.26	12.9	4.17	14.9	5.17	15.1	5.13	15.3	5.23	15.7	5.25	16.1	5.27
	35	10.8	3.47	12.9	4.46	14.6	5.35	14.8	5.37	15.1	5.42	15.4	5.44	15.8	5.46
37	10.8	3.60	12.9	4.59	14.4	5.44	14.6	5.45	14.8	5.50	15.2	5.53	15.6	5.55	
39	10.8	3.74	12.9	4.73	14.2	5.53	14.4	5.54	14.6	5.59	14.9	5.62	15.4	5.63	
100	10	9.5	1.65	11.3	2.01	13.1	2.38	14.0	2.57	14.9	2.76	16.8	3.08	18.4	3.10
	12	9.5	1.70	11.3	2.09	13.1	2.46	14.0	2.64	14.9	2.85	16.8	3.24	18.2	3.27
	14	9.5	1.76	11.3	2.17	13.1	2.56	14.0	2.76	14.9	2.97	16.8	3.42	18.0	3.45
	16	9.5	1.81	11.3	2.24	13.1	2.67	14.0	2.89	14.9	3.13	16.8	3.59	17.7	3.64
	18	9.5	1.86	11.3	2.33	13.1	2.78	14.0	3.03	14.9	3.32	16.8	3.79	17.5	3.82
	20	9.5	1.93	11.3	2.41	13.1	2.94	14.0	3.24	14.9	3.56	16.8	3.97	17.2	4.00
	21	9.5	1.97	11.3	2.47	13.1	3.04	14.0	3.35	14.9	3.69	16.8	4.06	17.1	4.10
	23	9.5	2.09	11.3	2.64	13.1	3.26	14.0	3.60	14.9	3.95	16.5	4.25	16.9	4.29
	25	9.5	2.22	11.3	2.82	13.1	3.49	14.0	3.85	14.9	4.23	16.3	4.44	16.6	4.47
	27	9.5	2.37	11.3	3.01	13.1	3.73	14.0	4.11	14.9	4.49	16.0	4.64	16.4	4.68
	29	9.5	2.52	11.3	3.21	13.1	3.98	14.0	4.40	14.9	4.75	15.8	4.83	16.2	4.87
	31	9.5	2.70	11.3	3.42	13.1	4.25	14.0	4.69	14.9	5.00	15.6	5.02	15.9	5.06
	33	9.5	2.86	11.3	3.65	13.1	4.53	14.0	5.01	14.9	5.18	15.3	5.21	15.7	5.25
	35	9.5	3.04	11.3	3.88	13.1	4.82	14.0	5.34	14.7	5.37	15.1	5.39	15.4	5.44
37	9.5	3.16	11.3	4.04	13.1	4.96	14.0	5.43	14.4	5.46	14.8	5.48	15.2	5.53	
39	9.5	3.28	11.3	4.20	13.1	5.09	14.0	5.52	14.2	5.54	14.6	5.57	15.0	5.62	

6. Capacity Tables

Combination (%)	Outdoor Air Temp. (°C DB)	Indoor Air Temp. (DB/WB, °C)													
		20		23		26		27		28		30		32	
		14		16		18		19		20		22		24	
		TC	PI	TC	PI	TC	PI	TC	PI	TC	PI	TC	PI	TC	PI
90	10	8.5	1.62	10.2	1.95	11.8	2.30	12.6	2.48	13.4	2.67	15.1	2.99	16.7	3.10
	12	8.5	1.64	10.2	1.98	11.8	2.34	12.6	2.53	13.4	2.73	15.1	3.04	16.7	3.27
	14	8.5	1.67	10.2	2.02	11.8	2.39	12.6	2.58	13.4	2.78	15.1	3.10	16.7	3.45
	16	8.5	1.70	10.2	2.06	11.8	2.44	12.6	2.63	13.4	2.83	15.1	3.16	16.7	3.51
	18	8.5	1.73	10.2	2.10	11.8	2.48	12.6	2.69	13.4	2.89	15.1	3.23	16.7	3.68
	20	8.5	1.76	10.2	2.14	11.8	2.53	12.6	2.74	13.4	3.00	15.1	3.46	16.7	3.86
	21	8.5	1.78	10.2	2.16	11.8	2.58	12.6	2.83	13.4	3.10	15.1	3.59	16.7	3.95
	23	8.5	1.82	10.2	2.25	11.8	2.76	12.6	3.04	13.4	3.32	15.1	3.84	16.5	4.13
	25	8.5	1.91	10.2	2.40	11.8	2.95	12.6	3.24	13.4	3.55	15.1	4.11	16.2	4.31
	27	8.5	2.04	10.2	2.56	11.8	3.14	12.6	3.46	13.4	3.80	15.1	4.37	16.0	4.51
	29	8.5	2.16	10.2	2.73	11.8	3.36	12.6	3.70	13.4	4.06	15.1	4.67	15.8	4.69
	31	8.5	2.30	10.2	2.91	11.8	3.58	12.6	3.94	13.4	4.33	15.1	4.86	15.5	4.88
	33	8.5	2.45	10.2	3.09	11.8	3.82	12.6	4.20	13.4	4.59	15.1	5.04	15.3	5.06
	35	8.5	2.60	10.2	3.28	11.8	4.06	12.6	4.48	13.4	4.87	14.8	5.22	15.0	5.24
37	8.5	2.76	10.2	3.49	11.8	4.33	12.6	4.76	13.4	5.14	14.6	5.41	14.8	5.42	
39	8.5	2.92	10.2	3.72	11.8	4.58	12.6	5.01	13.4	5.40	14.3	5.57	14.6	5.60	
80	10	7.6	1.43	9.0	1.72	10.5	2.02	11.2	2.18	12.0	2.34	13.4	2.67	14.9	2.90
	12	7.6	1.46	9.0	1.74	10.5	2.06	11.2	2.22	12.0	2.38	13.4	2.72	14.9	2.96
	14	7.6	1.48	9.0	1.78	10.5	2.09	11.2	2.26	12.0	2.42	13.4	2.77	14.9	3.01
	16	7.6	1.50	9.0	1.81	10.5	2.13	11.2	2.30	12.0	2.47	13.4	2.83	14.9	3.07
	18	7.6	1.53	9.0	1.84	10.5	2.17	11.2	2.34	12.0	2.52	13.4	2.88	14.9	3.14
	20	7.6	1.56	9.0	1.88	10.5	2.22	11.2	2.39	12.0	2.57	13.4	2.99	14.9	3.36
	21	7.6	1.57	9.0	1.90	10.5	2.24	11.2	2.42	12.0	2.63	13.4	3.08	14.9	3.48
	23	7.6	1.60	9.0	1.93	10.5	2.34	11.2	2.57	12.0	2.81	13.4	3.25	14.9	3.73
	25	7.6	1.66	9.0	2.06	10.5	2.51	11.2	2.75	12.0	3.01	13.4	3.48	14.9	3.99
	27	7.6	1.76	9.0	2.19	10.5	2.68	11.2	2.94	12.0	3.21	13.4	3.70	14.9	4.24
	29	7.6	1.87	9.0	2.34	10.5	2.85	11.2	3.13	12.0	3.43	13.4	3.97	14.9	4.54
	31	7.6	1.99	9.0	2.48	10.5	3.04	11.2	3.34	12.0	3.65	13.4	4.21	14.9	4.72
	33	7.6	2.11	9.0	2.65	10.5	3.24	11.2	3.56	12.0	3.88	13.4	4.43	14.9	4.89
	35	7.6	2.24	9.0	2.81	10.5	3.45	11.2	3.79	12.0	4.14	13.4	4.70	14.7	5.07
37	7.6	2.37	9.0	2.99	10.5	3.66	11.2	4.02	12.0	4.40	13.4	4.96	14.5	5.25	
39	7.6	2.51	9.0	3.16	10.5	3.87	11.2	4.24	12.0	4.68	13.4	5.19	14.2	5.43	
70	10	6.6	1.20	7.9	1.43	9.2	1.65	9.8	1.79	10.5	1.91	11.7	2.17	13.0	2.43
	12	6.6	1.22	7.9	1.45	9.2	1.69	9.8	1.81	10.5	1.95	11.7	2.21	13.0	2.48
	14	6.6	1.24	7.9	1.46	9.2	1.72	9.8	1.84	10.5	1.97	11.7	2.26	13.0	2.52
	16	6.6	1.26	7.9	1.49	9.2	1.75	9.8	1.88	10.5	2.01	11.7	2.30	13.0	2.58
	18	6.6	1.28	7.9	1.52	9.2	1.79	9.8	1.92	10.5	2.05	11.7	2.33	13.0	2.62
	20	6.6	1.29	7.9	1.55	9.2	1.81	9.8	1.96	10.5	2.10	11.7	2.39	13.0	2.72
	21	6.6	1.31	7.9	1.56	9.2	1.83	9.8	1.97	10.5	2.12	11.7	2.43	13.0	2.81
	23	6.6	1.33	7.9	1.60	9.2	1.87	9.8	2.04	10.5	2.22	11.7	2.60	13.0	2.96
	25	6.6	1.35	7.9	1.65	9.2	1.99	9.8	2.18	10.5	2.37	11.7	2.78	13.0	3.17
	27	6.6	1.43	7.9	1.77	9.2	2.13	9.8	2.31	10.5	2.53	11.7	2.97	13.0	3.37
	29	6.6	1.52	7.9	1.87	9.2	2.26	9.8	2.47	10.5	2.69	11.7	3.16	13.0	3.61
	31	6.6	1.62	7.9	1.99	9.2	2.41	9.8	2.64	10.5	2.87	11.7	3.37	13.0	3.83
	33	6.6	1.71	7.9	2.11	9.2	2.56	9.8	2.80	10.5	3.05	11.7	3.59	13.0	4.04
	35	6.6	1.80	7.9	2.25	9.2	2.72	9.8	2.98	10.5	3.25	11.7	3.83	13.0	4.28
37	6.6	1.92	7.9	2.38	9.2	2.89	9.8	3.16	10.5	3.46	11.7	4.07	13.0	4.52	
39	6.6	2.02	7.9	2.51	9.2	3.06	9.8	3.34	10.5	3.66	11.7	4.31	13.0	4.73	
60	10	5.7	0.98	6.8	1.15	7.9	1.34	8.4	1.44	9.0	1.53	10.1	1.73	11.2	1.94
	12	5.7	1.00	6.8	1.17	7.9	1.36	8.4	1.46	9.0	1.55	10.1	1.76	11.2	1.97
	14	5.7	1.01	6.8	1.19	7.9	1.38	8.4	1.48	9.0	1.58	10.1	1.80	11.2	2.01
	16	5.7	1.03	6.8	1.21	7.9	1.40	8.4	1.51	9.0	1.62	10.1	1.83	11.2	2.05
	18	5.7	1.05	6.8	1.23	7.9	1.43	8.4	1.54	9.0	1.64	10.1	1.86	11.2	2.09
	20	5.7	1.06	6.8	1.25	7.9	1.46	8.4	1.56	9.0	1.67	10.1	1.89	11.2	2.14
	21	5.7	1.07	6.8	1.26	7.9	1.47	8.4	1.58	9.0	1.69	10.1	1.92	11.2	2.15
	23	5.7	1.09	6.8	1.29	7.9	1.49	8.4	1.61	9.0	1.72	10.1	1.99	11.2	2.29
	25	5.7	1.11	6.8	1.31	7.9	1.55	8.4	1.69	9.0	1.83	10.1	2.13	11.2	2.45
	27	5.7	1.14	6.8	1.38	7.9	1.65	8.4	1.80	9.0	1.95	10.1	2.26	11.2	2.61
	29	5.7	1.21	6.8	1.47	7.9	1.76	8.4	1.91	9.0	2.07	10.1	2.41	11.2	2.79
	31	5.7	1.29	6.8	1.56	7.9	1.87	8.4	2.04	9.0	2.21	10.1	2.57	11.2	2.97
	33	5.7	1.36	6.8	1.65	7.9	1.98	8.4	2.16	9.0	2.35	10.1	2.73	11.2	3.16
	35	5.7	1.44	6.8	1.76	7.9	2.11	8.4	2.30	9.0	2.49	10.1	2.91	11.2	3.36
37	5.7	1.52	6.8	1.86	7.9	2.23	8.4	2.44	9.0	2.64	10.1	3.09	11.2	3.57	
39	5.7	1.60	6.8	1.96	7.9	2.36	8.4	2.59	9.0	2.79	10.1	3.28	11.2	3.79	

6. Capacity Tables

Combination (%)	Outdoor Air Temp. (°C DB)	Indoor Air Temp. (DB/WB, °C)													
		20		23		26		27		28		30		32	
		14		16		18		19		20		22		24	
		TC	PI	TC	PI	TC	PI	TC	PI	TC	PI	TC	PI	TC	PI
50	10	4.7	0.80	5.7	0.93	6.6	1.05	7.0	1.13	7.5	1.20	8.4	1.35	9.3	1.50
	12	4.7	0.81	5.7	0.93	6.6	1.07	7.0	1.15	7.5	1.22	8.4	1.37	9.3	1.52
	14	4.7	0.82	5.7	0.95	6.6	1.09	7.0	1.16	7.5	1.24	8.4	1.39	9.3	1.55
	16	4.7	0.83	5.7	0.97	6.6	1.10	7.0	1.19	7.5	1.25	8.4	1.41	9.3	1.57
	18	4.7	0.84	5.7	0.98	6.6	1.12	7.0	1.20	7.5	1.28	8.4	1.44	9.3	1.61
	20	4.7	0.85	5.7	0.99	6.6	1.15	7.0	1.22	7.5	1.30	8.4	1.46	9.3	1.64
	21	4.7	0.86	5.7	1.00	6.6	1.15	7.0	1.24	7.5	1.31	8.4	1.48	9.3	1.66
	23	4.7	0.88	5.7	1.02	6.6	1.17	7.0	1.25	7.5	1.34	8.4	1.51	9.3	1.69
	25	4.7	0.88	5.7	1.04	6.6	1.20	7.0	1.28	7.5	1.38	8.4	1.58	9.3	1.81
	27	4.7	0.90	5.7	1.07	6.6	1.26	7.0	1.36	7.5	1.46	8.4	1.69	9.3	1.93
	29	4.7	0.95	5.7	1.14	6.6	1.34	7.0	1.45	7.5	1.56	8.4	1.79	9.3	2.05
	31	4.7	1.00	5.7	1.20	6.6	1.42	7.0	1.53	7.5	1.66	8.4	1.91	9.3	2.18
	33	4.7	1.06	5.7	1.27	6.6	1.51	7.0	1.62	7.5	1.76	8.4	2.03	9.3	2.32
	35	4.7	1.12	5.7	1.35	6.6	1.59	7.0	1.73	7.5	1.86	8.4	2.15	9.3	2.47
	37	4.7	1.19	5.7	1.42	6.6	1.68	7.0	1.83	7.5	1.97	8.4	2.29	9.3	2.62
39	4.7	1.24	5.7	1.50	6.6	1.79	7.0	1.93	7.5	2.07	8.4	2.41	9.3	2.77	

Note

1. TC: Total Capacity(kW), PI : Power Input(kW, Comp. + Outdoor fan motor)
2. Capacity tables show the average value of conditions which may occur.

6. Capacity Tables

◆ ARUN050GSS0

Combination (%)	Outdoor Air Temp. (°C DB)	Indoor Air Temp. (DB/WB, °C)													
		20		23		26		27		28		30		32	
		14		16		18		19		20		22		24	
		TC	PI	TC	PI	TC	PI	TC	PI	TC	PI	TC	PI	TC	PI
130	10	12.8	1.95	15.2	2.38	17.7	2.76	18.4	2.82	18.6	2.85	19.0	2.86	19.5	2.88
	12	12.8	2.00	15.2	2.46	17.7	2.87	18.1	2.89	18.4	2.95	18.8	2.98	19.3	2.99
	14	12.8	2.06	15.2	2.55	17.6	2.98	17.9	3.00	18.1	3.06	18.6	3.08	19.0	3.11
	16	12.8	2.14	15.2	2.64	17.4	3.12	17.6	3.14	17.8	3.17	18.3	3.20	18.8	3.23
	18	12.8	2.23	15.2	2.80	17.2	3.28	17.4	3.31	17.6	3.33	18.1	3.35	18.6	3.37
	20	12.8	2.33	15.2	2.98	16.9	3.44	17.2	3.47	17.4	3.49	17.8	3.51	18.3	3.53
	21	12.8	2.39	15.2	3.08	16.8	3.52	17.1	3.55	17.3	3.57	17.7	3.59	18.2	3.61
	23	12.8	2.56	15.2	3.31	16.6	3.67	16.8	3.71	17.1	3.74	17.5	3.75	18.0	3.78
	25	12.8	2.73	15.2	3.54	16.3	3.83	16.6	3.87	16.8	3.90	17.3	3.92	17.7	3.94
	27	12.8	2.93	15.2	3.78	16.1	4.00	16.3	4.03	16.6	4.06	17.1	4.08	17.5	4.11
	29	12.8	3.12	15.2	4.04	15.9	4.16	16.1	4.19	16.3	4.22	16.8	4.24	17.3	4.27
	31	12.8	3.33	15.2	4.26	15.6	4.33	15.9	4.36	16.1	4.39	16.5	4.41	17.0	4.43
	33	12.8	3.54	14.9	4.42	15.4	4.50	15.7	4.52	15.9	4.55	16.3	4.57	16.8	4.60
	35	12.8	3.78	14.7	4.58	15.1	4.66	15.4	4.69	15.7	4.71	16.1	4.73	16.5	4.76
37	12.8	3.91	14.5	4.67	14.9	4.75	15.1	4.79	15.4	4.81	15.8	4.82	16.3	4.86	
39	12.8	4.05	14.2	4.76	14.7	4.85	14.9	4.88	15.1	4.90	15.6	4.92	16.1	4.95	
120	10	11.8	1.75	14.1	2.15	16.4	2.55	17.5	2.76	18.4	2.80	18.8	2.81	19.2	2.82
	12	11.8	1.80	14.1	2.22	16.4	2.65	17.5	2.82	18.1	2.91	18.5	2.94	18.9	2.95
	14	11.8	1.86	14.1	2.30	16.4	2.76	17.5	2.92	17.8	3.01	18.3	3.06	18.7	3.08
	16	11.8	1.93	14.1	2.39	16.4	2.87	17.4	3.08	17.6	3.15	18.0	3.16	18.5	3.20
	18	11.8	2.00	14.1	2.50	16.4	3.04	17.2	3.25	17.4	3.31	17.8	3.33	18.3	3.34
	20	11.8	2.08	14.1	2.65	16.4	3.24	16.9	3.44	17.2	3.47	17.6	3.49	18.0	3.50
	21	11.8	2.14	14.1	2.74	16.4	3.36	16.8	3.52	17.0	3.56	17.5	3.57	17.9	3.58
	23	11.8	2.29	14.1	2.94	16.4	3.58	16.6	3.68	16.8	3.72	17.2	3.73	17.6	3.75
	25	11.8	2.45	14.1	3.14	16.1	3.77	16.3	3.84	16.5	3.88	17.0	3.89	17.4	3.91
	27	11.8	2.61	14.1	3.36	15.9	3.97	16.1	4.00	16.3	4.04	16.7	4.06	17.2	4.07
	29	11.8	2.79	14.1	3.59	15.6	4.13	15.9	4.16	16.1	4.20	16.5	4.22	16.9	4.24
	31	11.8	2.97	14.1	3.83	15.4	4.30	15.6	4.32	15.9	4.36	16.3	4.38	16.7	4.40
	33	11.8	3.16	14.1	4.08	15.2	4.46	15.4	4.49	15.6	4.52	16.0	4.54	16.4	4.56
	35	11.8	3.36	14.1	4.35	14.9	4.63	15.1	4.65	15.4	4.69	15.8	4.71	16.2	4.72
37	11.8	3.51	14.1	4.46	14.7	4.71	14.9	4.74	15.1	4.76	15.5	4.79	16.0	4.80	
39	11.8	3.66	14.0	4.57	14.4	4.79	14.7	4.83	14.9	4.84	15.3	4.87	15.7	4.89	
110	10	10.8	1.58	12.9	1.92	15.0	2.28	16.0	2.47	17.1	2.66	18.4	2.77	18.8	2.78
	12	10.8	1.62	12.9	1.99	15.0	2.38	16.0	2.54	17.1	2.76	18.2	2.87	18.5	2.91
	14	10.8	1.68	12.9	2.07	15.0	2.48	16.0	2.66	17.1	2.90	17.9	2.98	18.3	3.04
	16	10.8	1.74	12.9	2.15	15.0	2.59	16.0	2.78	17.1	3.07	17.7	3.15	18.1	3.17
	18	10.8	1.80	12.9	2.24	15.0	2.73	16.0	2.96	17.1	3.25	17.4	3.31	17.9	3.32
	20	10.8	1.86	12.9	2.35	15.0	2.90	16.0	3.16	16.8	3.43	17.2	3.47	17.6	3.48
	21	10.8	1.90	12.9	2.42	15.0	3.00	16.0	3.27	16.7	3.51	17.1	3.55	17.5	3.56
	23	10.8	2.03	12.9	2.60	15.0	3.22	16.0	3.47	16.5	3.68	16.9	3.71	17.2	3.72
	25	10.8	2.17	12.9	2.77	15.0	3.45	16.0	3.68	16.2	3.83	16.6	3.87	17.0	3.89
	27	10.8	2.32	12.9	2.96	15.0	3.69	15.8	3.88	16.0	4.01	16.4	4.03	16.8	4.05
	29	10.8	2.47	12.9	3.16	15.0	3.94	15.6	4.05	15.8	4.17	16.1	4.19	16.6	4.21
	31	10.8	2.63	12.9	3.37	15.0	4.21	15.3	4.22	15.5	4.34	15.9	4.35	16.3	4.37
	33	10.8	2.80	12.9	3.59	14.9	4.44	15.1	4.41	15.3	4.50	15.7	4.52	16.1	4.53
	35	10.8	2.98	12.9	3.83	14.6	4.60	14.8	4.62	15.1	4.66	15.4	4.68	15.8	4.70
37	10.8	3.10	12.9	3.95	14.4	4.68	14.6	4.69	14.8	4.73	15.2	4.76	15.6	4.77	
39	10.8	3.21	12.9	4.06	14.2	4.75	14.4	4.76	14.6	4.80	14.9	4.83	15.4	4.84	
100	10	9.5	1.42	11.3	1.72	13.1	2.05	14.0	2.21	14.9	2.38	16.8	2.64	18.4	2.67
	12	9.5	1.46	11.3	1.79	13.1	2.11	14.0	2.27	14.9	2.45	16.8	2.79	18.2	2.81
	14	9.5	1.51	11.3	1.87	13.1	2.20	14.0	2.37	14.9	2.56	16.8	2.94	18.0	2.97
	16	9.5	1.56	11.3	1.93	13.1	2.30	14.0	2.48	14.9	2.69	16.8	3.08	17.7	3.13
	18	9.5	1.60	11.3	2.00	13.1	2.39	14.0	2.60	14.9	2.86	16.8	3.26	17.5	3.28
	20	9.5	1.66	11.3	2.08	13.1	2.53	14.0	2.79	14.9	3.06	16.8	3.41	17.2	3.44
	21	9.5	1.69	11.3	2.13	13.1	2.61	14.0	2.88	14.9	3.17	16.8	3.49	17.1	3.52
	23	9.5	1.79	11.3	2.27	13.1	2.80	14.0	3.09	14.9	3.40	16.5	3.66	16.9	3.69
	25	9.5	1.91	11.3	2.42	13.1	3.00	14.0	3.31	14.9	3.63	16.3	3.81	16.6	3.84
	27	9.5	2.04	11.3	2.59	13.1	3.21	14.0	3.54	14.9	3.86	16.0	3.99	16.4	4.02
	29	9.5	2.17	11.3	2.76	13.1	3.42	14.0	3.78	14.9	4.09	15.8	4.15	16.2	4.19
	31	9.5	2.32	11.3	2.94	13.1	3.65	14.0	4.03	14.9	4.29	15.6	4.31	15.9	4.35
	33	9.5	2.46	11.3	3.14	13.1	3.89	14.0	4.30	14.9	4.46	15.3	4.47	15.7	4.51
	35	9.5	2.61	11.3	3.34	13.1	4.15	14.0	4.59	14.7	4.62	15.1	4.64	15.4	4.67
37	9.5	2.72	11.3	3.47	13.1	4.26	14.0	4.67	14.4	4.69	14.8	4.71	15.2	4.75	
39	9.5	2.82	11.3	3.61	13.1	4.38	14.0	4.74	14.2	4.77	14.6	4.78	15.0	4.83	

6. Capacity Tables

Combination (%)	Outdoor Air Temp. (°C DB)	Indoor Air Temp. (DB/WB, °C)													
		20		23		26		27		28		30		32	
		14		16		18		19		20		22		24	
		TC	PI	TC	PI	TC	PI	TC	PI	TC	PI	TC	PI	TC	PI
90	10	8.5	1.42	10.2	1.72	11.8	2.05	12.6	2.21	13.4	2.38	15.1	2.64	16.7	2.67
	12	8.5	1.46	10.2	1.79	11.8	2.11	12.6	2.27	13.4	2.45	15.1	2.79	16.7	2.81
	14	8.5	1.51	10.2	1.87	11.8	2.20	12.6	2.37	13.4	2.56	15.1	2.94	16.7	2.97
	16	8.5	1.56	10.2	1.93	11.8	2.30	12.6	2.48	13.4	2.69	15.1	3.08	16.7	3.13
	18	8.5	1.60	10.2	2.00	11.8	2.39	12.6	2.60	13.4	2.86	15.1	3.23	16.7	3.28
	20	8.5	1.66	10.2	2.08	11.8	2.53	12.6	2.74	13.4	3.00	15.1	3.41	16.7	3.44
	21	8.5	1.69	10.2	2.13	11.8	2.58	12.6	2.83	13.4	3.10	15.1	3.49	16.7	3.52
	23	8.5	1.79	10.2	2.25	11.8	2.76	12.6	3.04	13.4	3.32	15.1	3.66	16.5	3.69
	25	8.5	1.91	10.2	2.40	11.8	2.95	12.6	3.24	13.4	3.55	15.1	3.81	16.2	3.84
	27	8.5	2.04	10.2	2.56	11.8	3.14	12.6	3.46	13.4	3.80	15.1	3.99	16.0	4.02
	29	8.5	2.16	10.2	2.73	11.8	3.36	12.6	3.70	13.4	4.06	15.1	4.15	15.8	4.19
	31	8.5	2.30	10.2	2.91	11.8	3.58	12.6	3.94	13.4	4.29	15.1	4.31	15.5	4.35
	33	8.5	2.45	10.2	3.09	11.8	3.82	12.6	4.20	13.4	4.46	15.1	4.47	15.3	4.51
	35	8.5	2.60	10.2	3.28	11.8	4.06	12.6	4.48	13.4	4.62	14.8	4.64	15.0	4.67
37	8.5	2.72	10.2	3.47	11.8	4.26	12.6	4.67	13.4	4.69	14.6	4.71	14.8	4.75	
39	8.5	2.82	10.2	3.61	11.8	4.38	12.6	4.74	13.4	4.77	14.3	4.78	14.6	4.83	
80	10	7.6	1.42	9.0	1.72	10.5	2.02	11.2	2.18	12.0	2.34	13.4	2.64	14.9	2.67
	12	7.6	1.46	9.0	1.74	10.5	2.06	11.2	2.22	12.0	2.38	13.4	2.72	14.9	2.81
	14	7.6	1.48	9.0	1.78	10.5	2.09	11.2	2.26	12.0	2.42	13.4	2.77	14.9	2.97
	16	7.6	1.50	9.0	1.81	10.5	2.13	11.2	2.30	12.0	2.47	13.4	2.83	14.9	3.07
	18	7.6	1.53	9.0	1.84	10.5	2.17	11.2	2.34	12.0	2.52	13.4	2.88	14.9	3.14
	20	7.6	1.56	9.0	1.88	10.5	2.22	11.2	2.39	12.0	2.57	13.4	2.99	14.9	3.36
	21	7.6	1.57	9.0	1.90	10.5	2.24	11.2	2.42	12.0	2.63	13.4	3.08	14.9	3.48
	23	7.6	1.60	9.0	1.93	10.5	2.34	11.2	2.57	12.0	2.81	13.4	3.25	14.9	3.69
	25	7.6	1.66	9.0	2.06	10.5	2.51	11.2	2.75	12.0	3.01	13.4	3.48	14.9	3.84
	27	7.6	1.76	9.0	2.19	10.5	2.68	11.2	2.94	12.0	3.21	13.4	3.70	14.9	4.02
	29	7.6	1.87	9.0	2.34	10.5	2.85	11.2	3.13	12.0	3.43	13.4	3.97	14.9	4.19
	31	7.6	1.99	9.0	2.48	10.5	3.04	11.2	3.34	12.0	3.65	13.4	4.21	14.9	4.35
	33	7.6	2.11	9.0	2.65	10.5	3.24	11.2	3.56	12.0	3.88	13.4	4.43	14.9	4.51
	35	7.6	2.24	9.0	2.81	10.5	3.45	11.2	3.79	12.0	4.14	13.4	4.64	14.7	4.67
37	7.6	2.37	9.0	2.99	10.5	3.66	11.2	4.02	12.0	4.40	13.4	4.71	14.5	4.75	
39	7.6	2.51	9.0	3.16	10.5	3.87	11.2	4.24	12.0	4.68	13.4	4.78	14.2	4.83	
70	10	6.6	1.20	7.9	1.43	9.2	1.65	9.8	1.79	10.5	1.91	11.7	2.17	13.0	2.43
	12	6.6	1.22	7.9	1.45	9.2	1.69	9.8	1.81	10.5	1.95	11.7	2.21	13.0	2.48
	14	6.6	1.24	7.9	1.46	9.2	1.72	9.8	1.84	10.5	1.97	11.7	2.26	13.0	2.52
	16	6.6	1.26	7.9	1.49	9.2	1.75	9.8	1.88	10.5	2.01	11.7	2.30	13.0	2.58
	18	6.6	1.28	7.9	1.52	9.2	1.79	9.8	1.92	10.5	2.05	11.7	2.33	13.0	2.62
	20	6.6	1.29	7.9	1.55	9.2	1.81	9.8	1.96	10.5	2.10	11.7	2.39	13.0	2.72
	21	6.6	1.31	7.9	1.56	9.2	1.83	9.8	1.97	10.5	2.12	11.7	2.43	13.0	2.81
	23	6.6	1.33	7.9	1.60	9.2	1.87	9.8	2.04	10.5	2.22	11.7	2.60	13.0	2.96
	25	6.6	1.35	7.9	1.65	9.2	1.99	9.8	2.18	10.5	2.37	11.7	2.78	13.0	3.17
	27	6.6	1.43	7.9	1.77	9.2	2.13	9.8	2.31	10.5	2.53	11.7	2.97	13.0	3.37
	29	6.6	1.52	7.9	1.87	9.2	2.26	9.8	2.47	10.5	2.69	11.7	3.16	13.0	3.61
	31	6.6	1.62	7.9	1.99	9.2	2.41	9.8	2.64	10.5	2.87	11.7	3.37	13.0	3.83
	33	6.6	1.71	7.9	2.11	9.2	2.56	9.8	2.80	10.5	3.05	11.7	3.59	13.0	4.04
	35	6.6	1.80	7.9	2.25	9.2	2.72	9.8	2.98	10.5	3.25	11.7	3.83	13.0	4.28
37	6.6	1.92	7.9	2.38	9.2	2.89	9.8	3.16	10.5	3.46	11.7	4.07	13.0	4.52	
39	6.6	2.02	7.9	2.51	9.2	3.06	9.8	3.34	10.5	3.66	11.7	4.31	13.0	4.73	
60	10	5.7	0.98	6.8	1.15	7.9	1.34	8.4	1.44	9.0	1.53	10.1	1.73	11.2	1.94
	12	5.7	1.00	6.8	1.17	7.9	1.36	8.4	1.46	9.0	1.55	10.1	1.76	11.2	1.97
	14	5.7	1.01	6.8	1.19	7.9	1.38	8.4	1.48	9.0	1.58	10.1	1.80	11.2	2.01
	16	5.7	1.03	6.8	1.21	7.9	1.40	8.4	1.51	9.0	1.62	10.1	1.83	11.2	2.05
	18	5.7	1.05	6.8	1.23	7.9	1.43	8.4	1.54	9.0	1.64	10.1	1.86	11.2	2.09
	20	5.7	1.06	6.8	1.25	7.9	1.46	8.4	1.56	9.0	1.67	10.1	1.89	11.2	2.14
	21	5.7	1.07	6.8	1.26	7.9	1.47	8.4	1.58	9.0	1.69	10.1	1.92	11.2	2.15
	23	5.7	1.09	6.8	1.29	7.9	1.49	8.4	1.61	9.0	1.72	10.1	1.99	11.2	2.29
	25	5.7	1.11	6.8	1.31	7.9	1.55	8.4	1.69	9.0	1.83	10.1	2.13	11.2	2.45
	27	5.7	1.14	6.8	1.38	7.9	1.65	8.4	1.80	9.0	1.95	10.1	2.26	11.2	2.61
	29	5.7	1.21	6.8	1.47	7.9	1.76	8.4	1.91	9.0	2.07	10.1	2.41	11.2	2.79
	31	5.7	1.29	6.8	1.56	7.9	1.87	8.4	2.04	9.0	2.21	10.1	2.57	11.2	2.97
	33	5.7	1.36	6.8	1.65	7.9	1.98	8.4	2.16	9.0	2.35	10.1	2.73	11.2	3.16
	35	5.7	1.44	6.8	1.76	7.9	2.11	8.4	2.30	9.0	2.49	10.1	2.91	11.2	3.36
37	5.7	1.52	6.8	1.86	7.9	2.23	8.4	2.44	9.0	2.64	10.1	3.09	11.2	3.57	
39	5.7	1.60	6.8	1.96	7.9	2.36	8.4	2.59	9.0	2.79	10.1	3.28	11.2	3.79	

6. Capacity Tables

Combination (%)	Outdoor Air Temp. (°C DB)	Indoor Air Temp. (DB/WB, °C)													
		20		23		26		27		28		30		32	
		14		16		18		19		20		22		24	
		TC	PI	TC	PI	TC	PI	TC	PI	TC	PI	TC	PI	TC	PI
50	10	4.7	0.80	5.7	0.93	6.6	1.05	7.0	1.13	7.5	1.20	8.4	1.35	9.3	1.50
	12	4.7	0.81	5.7	0.93	6.6	1.07	7.0	1.15	7.5	1.22	8.4	1.37	9.3	1.52
	14	4.7	0.82	5.7	0.95	6.6	1.09	7.0	1.16	7.5	1.24	8.4	1.39	9.3	1.55
	16	4.7	0.83	5.7	0.97	6.6	1.10	7.0	1.19	7.5	1.25	8.4	1.41	9.3	1.57
	18	4.7	0.84	5.7	0.98	6.6	1.12	7.0	1.20	7.5	1.28	8.4	1.44	9.3	1.61
	20	4.7	0.85	5.7	0.99	6.6	1.15	7.0	1.22	7.5	1.30	8.4	1.46	9.3	1.64
	21	4.7	0.86	5.7	1.00	6.6	1.15	7.0	1.24	7.5	1.31	8.4	1.48	9.3	1.66
	23	4.7	0.88	5.7	1.02	6.6	1.17	7.0	1.25	7.5	1.34	8.4	1.51	9.3	1.69
	25	4.7	0.88	5.7	1.04	6.6	1.20	7.0	1.28	7.5	1.38	8.4	1.58	9.3	1.81
	27	4.7	0.90	5.7	1.07	6.6	1.26	7.0	1.36	7.5	1.46	8.4	1.69	9.3	1.93
	29	4.7	0.95	5.7	1.14	6.6	1.34	7.0	1.45	7.5	1.56	8.4	1.79	9.3	2.05
	31	4.7	1.00	5.7	1.20	6.6	1.42	7.0	1.53	7.5	1.66	8.4	1.91	9.3	2.18
	33	4.7	1.06	5.7	1.27	6.6	1.51	7.0	1.62	7.5	1.76	8.4	2.03	9.3	2.32
	35	4.7	1.12	5.7	1.35	6.6	1.59	7.0	1.73	7.5	1.86	8.4	2.15	9.3	2.47
	37	4.7	1.19	5.7	1.42	6.6	1.68	7.0	1.83	7.5	1.97	8.4	2.29	9.3	2.62
39	4.7	1.24	5.7	1.50	6.6	1.79	7.0	1.93	7.5	2.07	8.4	2.41	9.3	2.77	

Note

1. TC: Total Capacity(kW), PI : Power Input(kW, Comp. + Outdoor fan motor)
2. Capacity tables show the average value of conditions which may occur.

6. Capacity Tables

◆ ARUN060GSS0

Combination (%)	Outdoor Air Temp. (°C DB)	Indoor Air Temp. (DB/WB, °C)													
		20		23		26		27		28		30		32	
		14		16		18		19		20		22		24	
		TC	PI	TC	PI	TC	PI	TC	PI	TC	PI	TC	PI	TC	PI
130	10	14.2	2.19	16.9	2.68	19.6	3.11	20.3	3.17	20.6	3.21	21.1	3.22	21.6	3.24
	12	14.2	2.25	16.9	2.78	19.6	3.24	20.0	3.26	20.4	3.32	20.8	3.35	21.3	3.37
	14	14.2	2.32	16.9	2.88	19.5	3.36	19.8	3.38	20.0	3.44	20.6	3.47	21.1	3.50
	16	14.2	2.41	16.9	2.98	19.3	3.51	19.5	3.54	19.8	3.57	20.3	3.60	20.8	3.63
	18	14.2	2.51	16.9	3.15	19.0	3.70	19.2	3.73	19.5	3.75	20.0	3.77	20.6	3.79
	20	14.2	2.62	16.9	3.36	18.7	3.88	19.0	3.91	19.2	3.93	19.8	3.95	20.3	3.98
	21	14.2	2.69	16.9	3.47	18.6	3.96	18.9	4.00	19.1	4.02	19.6	4.04	20.2	4.07
	23	14.2	2.88	16.9	3.73	18.4	4.13	18.6	4.17	18.9	4.21	19.4	4.23	19.9	4.25
	25	14.2	3.08	16.9	3.98	18.1	4.32	18.4	4.36	18.6	4.39	19.1	4.41	19.6	4.44
	27	14.2	3.30	16.9	4.26	17.9	4.51	18.1	4.54	18.4	4.57	18.9	4.60	19.4	4.62
	29	14.2	3.51	16.9	4.55	17.6	4.69	17.8	4.72	18.1	4.76	18.6	4.78	19.1	4.81
	31	14.2	3.75	16.8	4.79	17.3	4.88	17.6	4.91	17.8	4.94	18.3	4.96	18.8	4.99
	33	14.2	3.99	16.5	4.98	17.1	5.06	17.3	5.10	17.6	5.12	18.1	5.15	18.5	5.18
	35	14.2	4.26	16.2	5.16	16.8	5.25	17.1	5.28	17.3	5.30	17.8	5.33	18.3	5.36
37	14.2	4.41	16.0	5.26	16.5	5.35	16.8	5.40	17.1	5.42	17.5	5.43	18.0	5.47	
39	14.2	4.56	15.7	5.36	16.2	5.46	16.5	5.50	16.8	5.52	17.3	5.54	17.8	5.58	
120	10	13.1	1.97	15.6	2.42	18.1	2.87	19.4	3.11	20.3	3.16	20.8	3.17	21.2	3.18
	12	13.1	2.03	15.6	2.50	18.1	2.99	19.4	3.17	20.0	3.27	20.5	3.31	21.0	3.33
	14	13.1	2.10	15.6	2.59	18.1	3.11	19.4	3.29	19.7	3.39	20.3	3.44	20.7	3.47
	16	13.1	2.17	15.6	2.69	18.1	3.23	19.3	3.47	19.5	3.55	20.0	3.56	20.4	3.60
	18	13.1	2.26	15.6	2.81	18.1	3.43	19.0	3.66	19.2	3.73	19.7	3.75	20.2	3.76
	20	13.1	2.34	15.6	2.98	18.1	3.65	18.8	3.88	19.0	3.91	19.5	3.93	19.9	3.95
	21	13.1	2.41	15.6	3.09	18.1	3.78	18.6	3.96	18.8	4.00	19.3	4.02	19.8	4.04
	23	13.1	2.58	15.6	3.31	18.1	4.03	18.4	4.14	18.6	4.19	19.0	4.20	19.5	4.22
	25	13.1	2.76	15.6	3.54	17.8	4.25	18.1	4.33	18.3	4.37	18.8	4.39	19.3	4.40
	27	13.1	2.94	15.6	3.79	17.6	4.47	17.8	4.50	18.1	4.55	18.5	4.57	19.0	4.59
	29	13.1	3.14	15.6	4.04	17.3	4.65	17.5	4.69	17.8	4.73	18.2	4.75	18.8	4.77
	31	13.1	3.35	15.6	4.32	17.0	4.85	17.3	4.87	17.5	4.91	18.0	4.93	18.5	4.95
	33	13.1	3.56	15.6	4.60	16.8	5.02	17.0	5.05	17.3	5.10	17.7	5.12	18.2	5.14
	35	13.1	3.79	15.6	4.91	16.5	5.22	16.7	5.24	17.0	5.28	17.5	5.30	17.9	5.32
37	13.1	3.95	15.6	5.03	16.3	5.31	16.5	5.34	16.7	5.36	17.2	5.40	17.7	5.41	
39	13.1	4.12	15.5	5.15	16.0	5.40	16.2	5.44	16.4	5.45	17.0	5.49	17.4	5.50	
110	10	12.0	1.77	14.3	2.16	16.6	2.57	17.8	2.78	18.9	2.99	20.4	3.12	20.8	3.13
	12	12.0	1.83	14.3	2.24	16.6	2.68	17.8	2.86	18.9	3.11	20.1	3.23	20.5	3.28
	14	12.0	1.89	14.3	2.34	16.6	2.80	17.8	3.00	18.9	3.26	19.8	3.35	20.3	3.43
	16	12.0	1.95	14.3	2.42	16.6	2.91	17.8	3.13	18.9	3.46	19.6	3.54	20.0	3.57
	18	12.0	2.03	14.3	2.52	16.6	3.08	17.8	3.34	18.9	3.66	19.3	3.72	19.8	3.74
	20	12.0	2.10	14.3	2.65	16.6	3.27	17.8	3.56	18.6	3.87	19.1	3.91	19.5	3.92
	21	12.0	2.15	14.3	2.73	16.6	3.38	17.8	3.69	18.5	3.95	18.9	4.00	19.4	4.01
	23	12.0	2.29	14.3	2.92	16.6	3.63	17.8	3.91	18.2	4.14	18.7	4.18	19.1	4.19
	25	12.0	2.44	14.3	3.12	16.6	3.88	17.8	4.14	18.0	4.32	18.4	4.36	18.8	4.38
	27	12.0	2.61	14.3	3.34	16.6	4.16	17.5	4.37	17.7	4.52	18.2	4.54	18.6	4.56
	29	12.0	2.79	14.3	3.56	16.6	4.43	17.2	4.56	17.5	4.70	17.9	4.72	18.3	4.74
	31	12.0	2.96	14.3	3.80	16.6	4.74	16.9	4.76	17.2	4.88	17.6	4.90	18.0	4.92
	33	12.0	3.16	14.3	4.04	16.5	5.00	16.7	4.97	16.9	5.07	17.4	5.09	17.8	5.11
	35	12.0	3.36	14.3	4.32	16.2	5.18	16.4	5.20	16.7	5.25	17.1	5.27	17.5	5.29
37	12.0	3.49	14.3	4.45	16.0	5.27	16.2	5.28	16.4	5.32	16.8	5.36	17.2	5.37	
39	12.0	3.62	14.3	4.58	15.7	5.36	15.9	5.36	16.1	5.41	16.5	5.44	17.0	5.45	
100	10	10.5	1.60	12.5	1.94	14.5	2.30	15.5	2.49	16.5	2.68	18.5	2.98	20.4	3.00
	12	10.5	1.65	12.5	2.02	14.5	2.38	15.5	2.56	16.5	2.76	18.5	3.14	20.1	3.17
	14	10.5	1.70	12.5	2.10	14.5	2.48	15.5	2.67	16.5	2.88	18.5	3.31	19.9	3.34
	16	10.5	1.75	12.5	2.17	14.5	2.59	15.5	2.79	16.5	3.03	18.5	3.47	19.6	3.52
	18	10.5	1.80	12.5	2.25	14.5	2.69	15.5	2.93	16.5	3.22	18.5	3.67	19.3	3.70
	20	10.5	1.87	12.5	2.34	14.5	2.84	15.5	3.14	16.5	3.44	18.5	3.85	19.0	3.88
	21	10.5	1.91	12.5	2.39	14.5	2.94	15.5	3.25	16.5	3.57	18.5	3.93	18.9	3.97
	23	10.5	2.02	12.5	2.56	14.5	3.16	15.5	3.48	16.5	3.83	18.3	4.12	18.7	4.15
	25	10.5	2.15	12.5	2.73	14.5	3.37	15.5	3.73	16.5	4.09	18.0	4.29	18.4	4.33
	27	10.5	2.30	12.5	2.91	14.5	3.61	15.5	3.98	16.5	4.35	17.8	4.50	18.2	4.53
	29	10.5	2.44	12.5	3.11	14.5	3.86	15.5	4.26	16.5	4.60	17.5	4.68	17.9	4.72
	31	10.5	2.61	12.5	3.32	14.5	4.11	15.5	4.54	16.5	4.84	17.2	4.86	17.6	4.90
	33	10.5	2.77	12.5	3.53	14.5	4.39	15.5	4.85	16.5	5.02	17.0	5.04	17.3	5.08
	35	10.5	2.94	12.5	3.76	14.5	4.67	15.5	5.17	16.2	5.20	16.7	5.22	17.1	5.26
37	10.5	3.06	12.5	3.91	14.5	4.80	15.5	5.26	16.0	5.28	16.4	5.31	16.8	5.35	
39	10.5	3.18	12.5	4.07	14.5	4.93	15.5	5.34	15.7	5.37	16.2	5.39	16.6	5.44	

6. Capacity Tables

Combination (%)	Outdoor Air Temp. (°C DB)	Indoor Air Temp. (DB/WB, °C)													
		20		23		26		27		28		30		32	
		14		16		18		19		20		22		24	
		TC	PI	TC	PI	TC	PI	TC	PI	TC	PI	TC	PI	TC	PI
90	10	9.4	1.60	11.2	1.94	13.1	2.30	14.0	2.49	14.8	2.68	16.7	2.98	18.5	3.00
	12	9.4	1.65	11.2	2.02	13.1	2.38	14.0	2.56	14.8	2.76	16.7	3.14	18.5	3.17
	14	9.4	1.70	11.2	2.10	13.1	2.48	14.0	2.67	14.8	2.88	16.7	3.31	18.5	3.34
	16	9.4	1.75	11.2	2.17	13.1	2.59	14.0	2.79	14.8	3.03	16.7	3.47	18.5	3.52
	18	9.4	1.80	11.2	2.25	13.1	2.69	14.0	2.93	14.8	3.20	16.7	3.58	18.5	3.70
	20	9.4	1.87	11.2	2.34	13.1	2.80	14.0	3.03	14.8	3.32	16.7	3.83	18.5	3.88
	21	9.4	1.91	11.2	2.39	13.1	2.85	14.0	3.13	14.8	3.44	16.7	3.93	18.5	3.97
	23	9.4	2.02	11.2	2.49	13.1	3.05	14.0	3.36	14.8	3.68	16.7	4.12	18.2	4.15
	25	9.4	2.12	11.2	2.66	13.1	3.26	14.0	3.59	14.8	3.93	16.7	4.29	18.0	4.33
	27	9.4	2.26	11.2	2.83	13.1	3.48	14.0	3.83	14.8	4.21	16.7	4.50	17.7	4.53
	29	9.4	2.39	11.2	3.02	13.1	3.72	14.0	4.10	14.8	4.50	16.7	4.68	17.4	4.72
	31	9.4	2.55	11.2	3.22	13.1	3.97	14.0	4.36	14.8	4.79	16.7	4.86	17.2	4.90
	33	9.4	2.71	11.2	3.43	13.1	4.23	14.0	4.65	14.8	5.02	16.7	5.04	16.9	5.08
	35	9.4	2.88	11.2	3.64	13.1	4.50	14.0	4.96	14.8	5.20	16.4	5.22	16.7	5.26
37	9.4	3.05	11.2	3.87	13.1	4.79	14.0	5.26	14.8	5.28	16.1	5.31	16.4	5.35	
39	9.4	3.18	11.2	4.07	13.1	4.93	14.0	5.34	14.8	5.37	15.8	5.39	16.1	5.44	
80	10	8.4	1.59	10.0	1.91	11.6	2.24	12.4	2.42	13.2	2.59	14.8	2.96	16.4	3.00
	12	8.4	1.62	10.0	1.93	11.6	2.28	12.4	2.46	13.2	2.64	14.8	3.01	16.4	3.17
	14	8.4	1.64	10.0	1.97	11.6	2.32	12.4	2.50	13.2	2.68	14.8	3.07	16.4	3.34
	16	8.4	1.67	10.0	2.01	11.6	2.36	12.4	2.55	13.2	2.74	14.8	3.13	16.4	3.40
	18	8.4	1.70	10.0	2.04	11.6	2.40	12.4	2.59	13.2	2.79	14.8	3.19	16.4	3.47
	20	8.4	1.73	10.0	2.08	11.6	2.46	12.4	2.65	13.2	2.85	14.8	3.31	16.4	3.72
	21	8.4	1.74	10.0	2.11	11.6	2.48	12.4	2.68	13.2	2.91	14.8	3.41	16.4	3.86
	23	8.4	1.78	10.0	2.14	11.6	2.59	12.4	2.85	13.2	3.11	14.8	3.60	16.4	4.13
	25	8.4	1.84	10.0	2.28	11.6	2.78	12.4	3.04	13.2	3.33	14.8	3.86	16.4	4.33
	27	8.4	1.95	10.0	2.43	11.6	2.97	12.4	3.25	13.2	3.55	14.8	4.10	16.4	4.53
	29	8.4	2.07	10.0	2.59	11.6	3.15	12.4	3.46	13.2	3.79	14.8	4.39	16.4	4.72
	31	8.4	2.21	10.0	2.75	11.6	3.36	12.4	3.69	13.2	4.04	14.8	4.66	16.4	4.90
	33	8.4	2.34	10.0	2.93	11.6	3.58	12.4	3.94	13.2	4.30	14.8	4.91	16.4	5.08
	35	8.4	2.48	10.0	3.11	11.6	3.82	12.4	4.19	13.2	4.59	14.8	5.21	16.3	5.26
37	8.4	2.62	10.0	3.31	11.6	4.05	12.4	4.46	13.2	4.87	14.8	5.31	16.0	5.35	
39	8.4	2.77	10.0	3.50	11.6	4.29	12.4	4.70	13.2	5.19	14.8	5.39	15.7	5.44	
70	10	7.3	1.33	8.7	1.58	10.1	1.83	10.9	1.98	11.6	2.11	13.0	2.41	14.4	2.69
	12	7.3	1.35	8.7	1.60	10.1	1.87	10.9	2.01	11.6	2.15	13.0	2.45	14.4	2.74
	14	7.3	1.37	8.7	1.62	10.1	1.90	10.9	2.04	11.6	2.19	13.0	2.50	14.4	2.79
	16	7.3	1.39	8.7	1.65	10.1	1.94	10.9	2.08	11.6	2.23	13.0	2.54	14.4	2.85
	18	7.3	1.41	8.7	1.68	10.1	1.98	10.9	2.12	11.6	2.27	13.0	2.58	14.4	2.90
	20	7.3	1.43	8.7	1.72	10.1	2.01	10.9	2.17	11.6	2.32	13.0	2.65	14.4	3.01
	21	7.3	1.45	8.7	1.73	10.1	2.03	10.9	2.19	11.6	2.34	13.0	2.69	14.4	3.11
	23	7.3	1.47	8.7	1.77	10.1	2.07	10.9	2.26	11.6	2.46	13.0	2.88	14.4	3.28
	25	7.3	1.50	8.7	1.83	10.1	2.21	10.9	2.42	11.6	2.63	13.0	3.08	14.4	3.51
	27	7.3	1.58	8.7	1.96	10.1	2.35	10.9	2.56	11.6	2.80	13.0	3.28	14.4	3.73
	29	7.3	1.68	8.7	2.07	10.1	2.50	10.9	2.73	11.6	2.98	13.0	3.50	14.4	4.00
	31	7.3	1.79	8.7	2.21	10.1	2.67	10.9	2.92	11.6	3.18	13.0	3.73	14.4	4.24
	33	7.3	1.89	8.7	2.33	10.1	2.83	10.9	3.10	11.6	3.38	13.0	3.97	14.4	4.47
	35	7.3	2.00	8.7	2.49	10.1	3.01	10.9	3.29	11.6	3.60	13.0	4.24	14.4	4.74
37	7.3	2.12	8.7	2.64	10.1	3.20	10.9	3.50	11.6	3.83	13.0	4.51	14.4	5.00	
39	7.3	2.23	8.7	2.78	10.1	3.39	10.9	3.70	11.6	4.05	13.0	4.78	14.4	5.23	
60	10	6.3	1.09	7.5	1.28	8.7	1.48	9.3	1.59	9.9	1.69	11.1	1.92	12.3	2.15
	12	6.3	1.11	7.5	1.30	8.7	1.50	9.3	1.61	9.9	1.72	11.1	1.95	12.3	2.19
	14	6.3	1.12	7.5	1.32	8.7	1.53	9.3	1.64	9.9	1.75	11.1	1.99	12.3	2.23
	16	6.3	1.14	7.5	1.35	8.7	1.55	9.3	1.67	9.9	1.79	11.1	2.03	12.3	2.26
	18	6.3	1.16	7.5	1.36	8.7	1.58	9.3	1.70	9.9	1.82	11.1	2.06	12.3	2.31
	20	6.3	1.18	7.5	1.38	8.7	1.61	9.3	1.73	9.9	1.85	11.1	2.10	12.3	2.36
	21	6.3	1.19	7.5	1.39	8.7	1.63	9.3	1.75	9.9	1.87	11.1	2.13	12.3	2.38
	23	6.3	1.21	7.5	1.42	8.7	1.65	9.3	1.78	9.9	1.91	11.1	2.21	12.3	2.53
	25	6.3	1.23	7.5	1.45	8.7	1.72	9.3	1.87	9.9	2.03	11.1	2.35	12.3	2.71
	27	6.3	1.27	7.5	1.53	8.7	1.83	9.3	1.99	9.9	2.16	11.1	2.50	12.3	2.89
	29	6.3	1.35	7.5	1.63	8.7	1.95	9.3	2.12	9.9	2.29	11.1	2.67	12.3	3.09
	31	6.3	1.42	7.5	1.73	8.7	2.07	9.3	2.25	9.9	2.44	11.1	2.85	12.3	3.28
	33	6.3	1.50	7.5	1.83	8.7	2.20	9.3	2.39	9.9	2.60	11.1	3.03	12.3	3.50
	35	6.3	1.59	7.5	1.95	8.7	2.33	9.3	2.54	9.9	2.76	11.1	3.22	12.3	3.72
37	6.3	1.68	7.5	2.06	8.7	2.47	9.3	2.70	9.9	2.93	11.1	3.42	12.3	3.96	
39	6.3	1.77	7.5	2.17	8.7	2.62	9.3	2.87	9.9	3.09	11.1	3.63	12.3	4.20	

6. Capacity Tables

Combination (%)	Outdoor Air Temp. (°C DB)	Indoor Air Temp. (DB/WB, °C)													
		20		23		26		27		28		30		32	
		14		16		18		19		20		22		24	
		TC	PI	TC	PI	TC	PI	TC	PI	TC	PI	TC	PI	TC	PI
50	10	5.2	0.89	6.3	1.03	7.3	1.17	7.8	1.25	8.2	1.32	9.2	1.49	10.3	1.66
	12	5.2	0.89	6.3	1.03	7.3	1.18	7.8	1.27	8.2	1.35	9.2	1.52	10.3	1.69
	14	5.2	0.90	6.3	1.05	7.3	1.20	7.8	1.29	8.2	1.37	9.2	1.54	10.3	1.72
	16	5.2	0.92	6.3	1.07	7.3	1.22	7.8	1.31	8.2	1.39	9.2	1.57	10.3	1.74
	18	5.2	0.93	6.3	1.08	7.3	1.24	7.8	1.33	8.2	1.42	9.2	1.59	10.3	1.78
	20	5.2	0.94	6.3	1.10	7.3	1.27	7.8	1.35	8.2	1.44	9.2	1.62	10.3	1.82
	21	5.2	0.95	6.3	1.11	7.3	1.28	7.8	1.37	8.2	1.45	9.2	1.64	10.3	1.84
	23	5.2	0.97	6.3	1.13	7.3	1.30	7.8	1.39	8.2	1.48	9.2	1.67	10.3	1.87
	25	5.2	0.98	6.3	1.15	7.3	1.32	7.8	1.42	8.2	1.53	9.2	1.75	10.3	2.00
	27	5.2	1.00	6.3	1.18	7.3	1.40	7.8	1.51	8.2	1.62	9.2	1.87	10.3	2.13
	29	5.2	1.05	6.3	1.26	7.3	1.48	7.8	1.60	8.2	1.72	9.2	1.99	10.3	2.27
	31	5.2	1.11	6.3	1.33	7.3	1.58	7.8	1.70	8.2	1.84	9.2	2.12	10.3	2.41
	33	5.2	1.17	6.3	1.41	7.3	1.67	7.8	1.80	8.2	1.95	9.2	2.25	10.3	2.57
	35	5.2	1.24	6.3	1.49	7.3	1.76	7.8	1.91	8.2	2.06	9.2	2.38	10.3	2.73
	37	5.2	1.31	6.3	1.58	7.3	1.86	7.8	2.02	8.2	2.18	9.2	2.54	10.3	2.90
39	5.2	1.37	6.3	1.66	7.3	1.98	7.8	2.13	8.2	2.29	9.2	2.67	10.3	3.07	

Note

1. TC: Total Capacity(kW), PI : Power Input(kW, Comp. + Outdoor fan motor)
2. Capacity tables show the average value of conditions which may occur.

6. Capacity Tables

6.1.2 3 Phase / Heat Pump

◆ ARUN040LSS0

Combination (%)	Outdoor Air Temp. (°C DB)	Indoor Air Temp. (DB/WB, °C)													
		20		23		26		27		28		30		32	
		14		16		18		19		20		22		24	
		TC	PI	TC	PI	TC	PI	TC	PI	TC	PI	TC	PI	TC	PI
130	10	11.1	1.44	13.2	1.76	15.3	2.04	15.9	2.08	16.1	2.10	16.5	2.11	16.9	2.13
	12	11.1	1.47	13.2	1.82	15.3	2.12	15.6	2.14	15.9	2.18	16.2	2.20	16.6	2.21
	14	11.1	1.52	13.2	1.89	15.2	2.20	15.5	2.22	15.6	2.26	16.1	2.28	16.5	2.30
	16	11.1	1.58	13.2	1.95	15.1	2.30	15.2	2.32	15.4	2.34	15.8	2.36	16.2	2.38
	18	11.1	1.65	13.2	2.06	14.8	2.43	15.0	2.45	15.2	2.46	15.6	2.47	16.1	2.49
	20	11.1	1.72	13.2	2.20	14.6	2.54	14.9	2.56	15.0	2.58	15.4	2.59	15.8	2.61
	21	11.1	1.76	13.2	2.28	14.5	2.60	14.7	2.63	14.9	2.64	15.3	2.65	15.7	2.67
	23	11.1	1.89	13.2	2.44	14.3	2.71	14.5	2.74	14.7	2.76	15.1	2.77	15.5	2.79
	25	11.1	2.02	13.2	2.61	14.1	2.83	14.4	2.86	14.5	2.88	14.9	2.89	15.3	2.91
	27	11.1	2.16	13.2	2.79	13.9	2.95	14.1	2.98	14.4	3.00	14.7	3.01	15.1	3.03
	29	11.1	2.30	13.2	2.98	13.7	3.08	13.9	3.10	14.1	3.12	14.5	3.13	14.9	3.15
	31	11.1	2.46	13.1	3.14	13.5	3.20	13.7	3.22	13.9	3.24	14.3	3.25	14.7	3.27
	33	11.1	2.62	12.9	3.26	13.3	3.32	13.5	3.34	13.7	3.36	14.1	3.38	14.5	3.40
	35	11.1	2.79	12.7	3.38	13.1	3.44	13.3	3.46	13.5	3.48	13.9	3.50	14.3	3.52
37	11.1	2.89	12.5	3.45	12.9	3.51	13.1	3.54	13.3	3.55	13.7	3.56	14.1	3.59	
39	11.1	2.99	12.3	3.52	12.7	3.58	12.9	3.61	13.1	3.62	13.5	3.63	13.9	3.66	
120	10	10.2	1.29	12.2	1.59	14.1	1.88	15.1	2.04	15.9	2.07	16.2	2.08	16.6	2.09
	12	10.2	1.33	12.2	1.64	14.1	1.96	15.1	2.08	15.6	2.15	16.0	2.17	16.4	2.18
	14	10.2	1.37	12.2	1.70	14.1	2.04	15.1	2.16	15.4	2.22	15.8	2.26	16.2	2.28
	16	10.2	1.42	12.2	1.76	14.1	2.12	15.0	2.27	15.2	2.33	15.6	2.34	16.0	2.36
	18	10.2	1.48	12.2	1.84	14.1	2.25	14.8	2.40	15.0	2.45	15.4	2.46	15.8	2.47
	20	10.2	1.54	12.2	1.96	14.1	2.39	14.6	2.54	14.8	2.57	15.2	2.58	15.5	2.59
	21	10.2	1.58	12.2	2.03	14.1	2.48	14.5	2.60	14.7	2.63	15.1	2.64	15.5	2.65
	23	10.2	1.69	12.2	2.17	14.1	2.64	14.3	2.71	14.5	2.75	14.9	2.76	15.2	2.77
	25	10.2	1.81	12.2	2.32	13.9	2.79	14.1	2.84	14.3	2.86	14.7	2.88	15.0	2.89
	27	10.2	1.93	12.2	2.48	13.7	2.93	13.9	2.95	14.1	2.98	14.5	3.00	14.8	3.01
	29	10.2	2.06	12.2	2.65	13.5	3.05	13.7	3.07	13.9	3.10	14.2	3.12	14.6	3.13
	31	10.2	2.19	12.2	2.83	13.3	3.18	13.5	3.19	13.7	3.22	14.1	3.24	14.4	3.25
	33	10.2	2.34	12.2	3.02	13.1	3.29	13.3	3.31	13.5	3.34	13.8	3.36	14.2	3.37
	35	10.2	2.48	12.2	3.22	12.9	3.42	13.1	3.44	13.3	3.46	13.7	3.48	14.0	3.49
37	10.2	2.59	12.2	3.30	12.7	3.48	12.9	3.50	13.1	3.52	13.4	3.54	13.8	3.55	
39	10.2	2.70	12.1	3.37	12.5	3.54	12.7	3.57	12.8	3.58	13.3	3.60	13.6	3.61	
110	10	9.4	1.16	11.2	1.42	13.0	1.68	13.9	1.82	14.8	1.96	15.9	2.04	16.2	2.05
	12	9.4	1.20	11.2	1.47	13.0	1.75	13.9	1.88	14.8	2.04	15.7	2.12	16.0	2.15
	14	9.4	1.24	11.2	1.53	13.0	1.83	13.9	1.97	14.8	2.14	15.5	2.20	15.8	2.25
	16	9.4	1.28	11.2	1.59	13.0	1.91	13.9	2.05	14.8	2.27	15.3	2.32	15.6	2.34
	18	9.4	1.33	11.2	1.65	13.0	2.02	13.9	2.19	14.8	2.40	15.1	2.44	15.4	2.45
	20	9.4	1.38	11.2	1.74	13.0	2.14	13.9	2.33	14.5	2.53	14.9	2.56	15.2	2.57
	21	9.4	1.41	11.2	1.79	13.0	2.22	13.9	2.42	14.4	2.59	14.8	2.62	15.1	2.63
	23	9.4	1.50	11.2	1.92	13.0	2.38	13.9	2.56	14.2	2.71	14.6	2.74	14.9	2.75
	25	9.4	1.60	11.2	2.05	13.0	2.55	13.9	2.72	14.0	2.83	14.4	2.86	14.7	2.87
	27	9.4	1.71	11.2	2.19	13.0	2.73	13.6	2.87	13.8	2.96	14.2	2.98	14.5	2.99
	29	9.4	1.83	11.2	2.34	13.0	2.91	13.5	2.99	13.6	3.08	14.0	3.10	14.3	3.11
	31	9.4	1.94	11.2	2.49	13.0	3.11	13.2	3.12	13.4	3.20	13.8	3.22	14.1	3.23
	33	9.4	2.07	11.2	2.65	12.9	3.28	13.1	3.26	13.2	3.32	13.5	3.34	13.9	3.35
	35	9.4	2.20	11.2	2.83	12.6	3.40	12.8	3.41	13.0	3.44	13.3	3.45	13.7	3.47
37	9.4	2.29	11.2	2.92	12.5	3.46	12.6	3.46	12.8	3.49	13.1	3.51	13.5	3.52	
39	9.4	2.37	11.2	3.00	12.2	3.51	12.4	3.52	12.6	3.55	12.9	3.57	13.3	3.58	
100	10	8.2	1.05	9.7	1.27	11.3	1.51	12.1	1.63	12.9	1.75	14.5	1.95	15.9	1.97
	12	8.2	1.08	9.7	1.33	11.3	1.56	12.1	1.68	12.9	1.81	14.5	2.06	15.7	2.08
	14	8.2	1.12	9.7	1.38	11.3	1.63	12.1	1.75	12.9	1.89	14.5	2.17	15.5	2.19
	16	8.2	1.15	9.7	1.42	11.3	1.70	12.1	1.83	12.9	1.99	14.5	2.28	15.3	2.31
	18	8.2	1.18	9.7	1.48	11.3	1.76	12.1	1.92	12.9	2.11	14.5	2.41	15.1	2.43
	20	8.2	1.23	9.7	1.53	11.3	1.87	12.1	2.06	12.9	2.26	14.5	2.52	14.9	2.54
	21	8.2	1.25	9.7	1.57	11.3	1.93	12.1	2.13	12.9	2.34	14.5	2.58	14.8	2.60
	23	8.2	1.33	9.7	1.68	11.3	2.07	12.1	2.28	12.9	2.51	14.3	2.70	14.6	2.72
	25	8.2	1.41	9.7	1.79	11.3	2.21	12.1	2.44	12.9	2.68	14.1	2.82	14.3	2.84
	27	8.2	1.51	9.7	1.91	11.3	2.37	12.1	2.61	12.9	2.85	13.9	2.95	14.2	2.97
	29	8.2	1.60	9.7	2.04	11.3	2.53	12.1	2.79	12.9	3.02	13.7	3.07	14.0	3.09
	31	8.2	1.71	9.7	2.17	11.3	2.70	12.1	2.98	12.9	3.17	13.4	3.19	13.7	3.21
	33	8.2	1.81	9.7	2.32	11.3	2.88	12.1	3.18	12.9	3.29	13.2	3.30	13.5	3.33
	35	8.2	1.93	9.7	2.46	11.3	3.06	12.1	3.39	12.7	3.41	13.0	3.42	13.3	3.45
37	8.2	2.01	9.7	2.57	11.3	3.15	12.1	3.45	12.5	3.46	12.8	3.48	13.1	3.51	
39	8.2	2.08	9.7	2.67	11.3	3.23	12.1	3.50	12.3	3.52	12.6	3.53	12.9	3.57	

6. Capacity Tables

Combination (%)	Outdoor Air Temp. (°C DB)	Indoor Air Temp. (DB/WB, °C)													
		20		23		26		27		28		30		32	
		14		16		18		19		20		22		24	
		TC	PI	TC	PI	TC	PI	TC	PI	TC	PI	TC	PI	TC	PI
90	10	7.3	1.05	8.8	1.27	10.2	1.51	10.9	1.63	11.6	1.75	13.0	1.95	14.4	1.97
	12	7.3	1.08	8.8	1.33	10.2	1.56	10.9	1.68	11.6	1.81	13.0	2.06	14.4	2.08
	14	7.3	1.12	8.8	1.38	10.2	1.63	10.9	1.75	11.6	1.89	13.0	2.17	14.4	2.19
	16	7.3	1.15	8.8	1.42	10.2	1.70	10.9	1.83	11.6	1.99	13.0	2.28	14.4	2.31
	18	7.3	1.18	8.8	1.48	10.2	1.76	10.9	1.92	11.6	2.11	13.0	2.41	14.4	2.43
	20	7.3	1.23	8.8	1.53	10.2	1.87	10.9	2.06	11.6	2.26	13.0	2.52	14.4	2.54
	21	7.3	1.25	8.8	1.57	10.2	1.93	10.9	2.13	11.6	2.34	13.0	2.58	14.4	2.60
	23	7.3	1.33	8.8	1.68	10.2	2.07	10.9	2.28	11.6	2.51	13.0	2.70	14.2	2.72
	25	7.3	1.41	8.8	1.79	10.2	2.21	10.9	2.44	11.6	2.68	13.0	2.82	14.0	2.84
	27	7.3	1.51	8.8	1.91	10.2	2.37	10.9	2.61	11.6	2.85	13.0	2.95	13.8	2.97
	29	7.3	1.60	8.8	2.04	10.2	2.53	10.9	2.79	11.6	3.02	13.0	3.07	13.6	3.09
	31	7.3	1.71	8.8	2.17	10.2	2.70	10.9	2.98	11.6	3.17	13.0	3.19	13.4	3.21
	33	7.3	1.81	8.8	2.32	10.2	2.88	10.9	3.18	11.6	3.29	13.0	3.30	13.2	3.33
	35	7.3	1.93	8.8	2.46	10.2	3.06	10.9	3.39	11.6	3.41	12.8	3.42	13.0	3.45
37	7.3	2.01	8.8	2.57	10.2	3.15	10.9	3.45	11.6	3.46	12.6	3.48	12.8	3.51	
39	7.3	2.08	8.8	2.67	10.2	3.23	10.9	3.50	11.6	3.52	12.4	3.53	12.6	3.57	
80	10	6.5	1.05	7.8	1.27	9.0	1.51	9.7	1.63	10.3	1.75	11.6	1.95	12.8	1.97
	12	6.5	1.08	7.8	1.33	9.0	1.56	9.7	1.68	10.3	1.81	11.6	2.06	12.8	2.08
	14	6.5	1.12	7.8	1.38	9.0	1.63	9.7	1.75	10.3	1.89	11.6	2.17	12.8	2.19
	16	6.5	1.15	7.8	1.42	9.0	1.70	9.7	1.83	10.3	1.99	11.6	2.28	12.8	2.31
	18	6.5	1.18	7.8	1.48	9.0	1.76	9.7	1.92	10.3	2.11	11.6	2.41	12.8	2.43
	20	6.5	1.23	7.8	1.53	9.0	1.87	9.7	2.06	10.3	2.22	11.6	2.52	12.8	2.54
	21	6.5	1.25	7.8	1.57	9.0	1.93	9.7	2.09	10.3	2.27	11.6	2.58	12.8	2.60
	23	6.5	1.33	7.8	1.67	9.0	2.02	9.7	2.22	10.3	2.43	11.6	2.70	12.8	2.72
	25	6.5	1.41	7.8	1.78	9.0	2.17	9.7	2.38	10.3	2.60	11.6	2.82	12.8	2.84
	27	6.5	1.51	7.8	1.89	9.0	2.32	9.7	2.54	10.3	2.77	11.6	2.95	12.8	2.97
	29	6.5	1.60	7.8	2.02	9.0	2.46	9.7	2.70	10.3	2.96	11.6	3.07	12.8	3.09
	31	6.5	1.71	7.8	2.14	9.0	2.63	9.7	2.88	10.3	3.15	11.6	3.19	12.8	3.21
	33	6.5	1.81	7.8	2.29	9.0	2.80	9.7	3.07	10.3	3.29	11.6	3.30	12.8	3.33
	35	6.5	1.93	7.8	2.43	9.0	2.98	9.7	3.27	10.3	3.41	11.6	3.42	12.7	3.45
37	6.5	2.01	7.8	2.57	9.0	3.15	9.7	3.45	10.3	3.46	11.6	3.48	12.5	3.51	
39	6.5	2.08	7.8	2.67	9.0	3.23	9.7	3.50	10.3	3.52	11.6	3.53	12.3	3.57	
70	10	5.7	1.04	6.8	1.23	7.9	1.43	8.5	1.54	9.0	1.65	10.1	1.88	11.2	1.97
	12	5.7	1.05	6.8	1.25	7.9	1.46	8.5	1.57	9.0	1.68	10.1	1.91	11.2	2.08
	14	5.7	1.07	6.8	1.27	7.9	1.49	8.5	1.59	9.0	1.71	10.1	1.95	11.2	2.18
	16	5.7	1.09	6.8	1.29	7.9	1.51	8.5	1.62	9.0	1.74	10.1	1.98	11.2	2.23
	18	5.7	1.10	6.8	1.31	7.9	1.54	8.5	1.66	9.0	1.77	10.1	2.02	11.2	2.27
	20	5.7	1.12	6.8	1.34	7.9	1.57	8.5	1.69	9.0	1.81	10.1	2.07	11.2	2.35
	21	5.7	1.13	6.8	1.35	7.9	1.58	8.5	1.71	9.0	1.83	10.1	2.10	11.2	2.43
	23	5.7	1.15	6.8	1.38	7.9	1.62	8.5	1.76	9.0	1.92	10.1	2.25	11.2	2.56
	25	5.7	1.17	6.8	1.43	7.9	1.72	8.5	1.89	9.0	2.05	10.1	2.40	11.2	2.74
	27	5.7	1.23	6.8	1.53	7.9	1.84	8.5	2.00	9.0	2.19	10.1	2.56	11.2	2.91
	29	5.7	1.31	6.8	1.62	7.9	1.95	8.5	2.13	9.0	2.33	10.1	2.74	11.2	3.09
	31	5.7	1.40	6.8	1.72	7.9	2.08	8.5	2.28	9.0	2.48	10.1	2.91	11.2	3.21
	33	5.7	1.48	6.8	1.82	7.9	2.21	8.5	2.42	9.0	2.64	10.1	3.10	11.2	3.33
	35	5.7	1.56	6.8	1.94	7.9	2.35	8.5	2.57	9.0	2.81	10.1	3.31	11.2	3.45
37	5.7	1.66	6.8	2.06	7.9	2.50	8.5	2.74	9.0	2.99	10.1	3.48	11.2	3.51	
39	5.7	1.74	6.8	2.17	7.9	2.65	8.5	2.89	9.0	3.16	10.1	3.53	11.2	3.57	
60	10	4.9	0.85	5.8	1.00	6.8	1.16	7.3	1.24	7.7	1.32	8.7	1.50	9.6	1.68
	12	4.9	0.86	5.8	1.01	6.8	1.17	7.3	1.26	7.7	1.34	8.7	1.52	9.6	1.71
	14	4.9	0.87	5.8	1.03	6.8	1.20	7.3	1.28	7.7	1.37	8.7	1.55	9.6	1.74
	16	4.9	0.89	5.8	1.05	6.8	1.21	7.3	1.30	7.7	1.40	8.7	1.58	9.6	1.77
	18	4.9	0.90	5.8	1.07	6.8	1.24	7.3	1.33	7.7	1.42	8.7	1.61	9.6	1.81
	20	4.9	0.92	5.8	1.08	6.8	1.26	7.3	1.35	7.7	1.44	8.7	1.64	9.6	1.85
	21	4.9	0.93	5.8	1.09	6.8	1.27	7.3	1.37	7.7	1.46	8.7	1.66	9.6	1.86
	23	4.9	0.94	5.8	1.11	6.8	1.29	7.3	1.39	7.7	1.49	8.7	1.72	9.6	1.98
	25	4.9	0.96	5.8	1.13	6.8	1.34	7.3	1.46	7.7	1.58	8.7	1.84	9.6	2.12
	27	4.9	0.99	5.8	1.20	6.8	1.43	7.3	1.55	7.7	1.68	8.7	1.95	9.6	2.25
	29	4.9	1.05	5.8	1.27	6.8	1.52	7.3	1.65	7.7	1.79	8.7	2.08	9.6	2.41
	31	4.9	1.11	5.8	1.35	6.8	1.61	7.3	1.76	7.7	1.91	8.7	2.22	9.6	2.56
	33	4.9	1.17	5.8	1.43	6.8	1.71	7.3	1.87	7.7	2.03	8.7	2.36	9.6	2.73
	35	4.9	1.24	5.8	1.52	6.8	1.82	7.3	1.98	7.7	2.15	8.7	2.52	9.6	2.90
37	4.9	1.31	5.8	1.61	6.8	1.93	7.3	2.11	7.7	2.29	8.7	2.67	9.6	3.09	
39	4.9	1.38	5.8	1.69	6.8	2.04	7.3	2.24	7.7	2.41	8.7	2.84	9.6	3.28	

6. Capacity Tables

Combination (%)	Outdoor Air Temp. (°C DB)	Indoor Air Temp. (DB/WB, °C)													
		20		23		26		27		28		30		32	
		14		16		18		19		20		22		24	
		TC	PI	TC	PI	TC	PI	TC	PI	TC	PI	TC	PI	TC	PI
50	10	4.1	0.69	4.9	0.80	5.7	0.91	6.1	0.98	6.4	1.03	7.2	1.16	8.0	1.30
	12	4.1	0.70	4.9	0.81	5.7	0.92	6.1	0.99	6.4	1.06	7.2	1.19	8.0	1.32
	14	4.1	0.71	4.9	0.82	5.7	0.94	6.1	1.00	6.4	1.07	7.2	1.20	8.0	1.34
	16	4.1	0.72	4.9	0.84	5.7	0.95	6.1	1.03	6.4	1.08	7.2	1.22	8.0	1.36
	18	4.1	0.73	4.9	0.84	5.7	0.97	6.1	1.04	6.4	1.11	7.2	1.24	8.0	1.39
	20	4.1	0.73	4.9	0.86	5.7	0.99	6.1	1.06	6.4	1.13	7.2	1.27	8.0	1.42
	21	4.1	0.74	4.9	0.87	5.7	1.00	6.1	1.07	6.4	1.14	7.2	1.28	8.0	1.43
	23	4.1	0.76	4.9	0.88	5.7	1.01	6.1	1.08	6.4	1.16	7.2	1.30	8.0	1.46
	25	4.1	0.76	4.9	0.90	5.7	1.03	6.1	1.11	6.4	1.19	7.2	1.37	8.0	1.56
	27	4.1	0.78	4.9	0.92	5.7	1.09	6.1	1.18	6.4	1.27	7.2	1.46	8.0	1.67
	29	4.1	0.82	4.9	0.98	5.7	1.16	6.1	1.25	6.4	1.35	7.2	1.55	8.0	1.77
	31	4.1	0.87	4.9	1.04	5.7	1.23	6.1	1.32	6.4	1.43	7.2	1.65	8.0	1.88
	33	4.1	0.92	4.9	1.10	5.7	1.30	6.1	1.40	6.4	1.52	7.2	1.75	8.0	2.01
	35	4.1	0.97	4.9	1.16	5.7	1.38	6.1	1.49	6.4	1.61	7.2	1.86	8.0	2.13
	37	4.1	1.03	4.9	1.23	5.7	1.46	6.1	1.58	6.4	1.70	7.2	1.98	8.0	2.26
39	4.1	1.07	4.9	1.29	5.7	1.54	6.1	1.67	6.4	1.79	7.2	2.09	8.0	2.40	

Note

1. TC: Total Capacity(kW), PI : Power Input(kW, Comp. + Outdoor fan motor)
2. Capacity tables show the average value of conditions which may occur.

6. Capacity Tables

◆ ARUN050LSS0

Combination (%)	Outdoor Air Temp. (°C DB)	Indoor Air Temp. (DB/WB, °C)													
		20		23		26		27		28		30		32	
		14		16		18		19		20		22		24	
		TC	PI	TC	PI	TC	PI	TC	PI	TC	PI	TC	PI	TC	PI
130	10	12.8	1.95	15.2	2.38	17.7	2.76	18.4	2.82	18.6	2.85	19.0	2.86	19.5	2.88
	12	12.8	2.00	15.2	2.46	17.7	2.87	18.1	2.89	18.4	2.95	18.8	2.98	19.3	2.99
	14	12.8	2.06	15.2	2.55	17.6	2.98	17.9	3.00	18.1	3.06	18.6	3.08	19.0	3.11
	16	12.8	2.14	15.2	2.64	17.4	3.12	17.6	3.14	17.8	3.17	18.3	3.20	18.8	3.23
	18	12.8	2.23	15.2	2.80	17.2	3.28	17.4	3.31	17.6	3.33	18.1	3.35	18.6	3.37
	20	12.8	2.33	15.2	2.98	16.9	3.44	17.2	3.47	17.4	3.49	17.8	3.51	18.3	3.53
	21	12.8	2.39	15.2	3.08	16.8	3.52	17.1	3.55	17.3	3.57	17.7	3.59	18.2	3.61
	23	12.8	2.56	15.2	3.31	16.6	3.67	16.8	3.71	17.1	3.74	17.5	3.75	18.0	3.78
	25	12.8	2.73	15.2	3.54	16.3	3.83	16.6	3.87	16.8	3.90	17.3	3.92	17.7	3.94
	27	12.8	2.93	15.2	3.78	16.1	4.00	16.3	4.03	16.6	4.06	17.1	4.08	17.5	4.11
	29	12.8	3.12	15.2	4.04	15.9	4.16	16.1	4.19	16.3	4.22	16.8	4.24	17.3	4.27
	31	12.8	3.33	15.2	4.26	15.6	4.33	15.9	4.36	16.1	4.39	16.5	4.41	17.0	4.43
	33	12.8	3.54	14.9	4.42	15.4	4.50	15.7	4.52	15.9	4.55	16.3	4.57	16.8	4.60
	35	12.8	3.78	14.7	4.58	15.1	4.66	15.4	4.69	15.7	4.71	16.1	4.73	16.5	4.76
37	12.8	3.91	14.5	4.67	14.9	4.75	15.1	4.79	15.4	4.81	15.8	4.82	16.3	4.86	
39	12.8	4.05	14.2	4.76	14.7	4.85	14.9	4.88	15.1	4.90	15.6	4.92	16.1	4.95	
120	10	11.8	1.75	14.1	2.15	16.4	2.55	17.5	2.76	18.4	2.80	18.8	2.81	19.2	2.82
	12	11.8	1.80	14.1	2.22	16.4	2.65	17.5	2.82	18.1	2.91	18.5	2.94	18.9	2.95
	14	11.8	1.86	14.1	2.30	16.4	2.76	17.5	2.92	17.8	3.01	18.3	3.06	18.7	3.08
	16	11.8	1.93	14.1	2.39	16.4	2.87	17.4	3.08	17.6	3.15	18.0	3.16	18.5	3.20
	18	11.8	2.00	14.1	2.50	16.4	3.04	17.2	3.25	17.4	3.31	17.8	3.33	18.3	3.34
	20	11.8	2.08	14.1	2.65	16.4	3.24	16.9	3.44	17.2	3.47	17.6	3.49	18.0	3.50
	21	11.8	2.14	14.1	2.74	16.4	3.36	16.8	3.52	17.0	3.56	17.5	3.57	17.9	3.58
	23	11.8	2.29	14.1	2.94	16.4	3.58	16.6	3.68	16.8	3.72	17.2	3.73	17.6	3.75
	25	11.8	2.45	14.1	3.14	16.1	3.77	16.3	3.84	16.5	3.88	17.0	3.89	17.4	3.91
	27	11.8	2.61	14.1	3.36	15.9	3.97	16.1	4.00	16.3	4.04	16.7	4.06	17.2	4.07
	29	11.8	2.79	14.1	3.59	15.6	4.13	15.9	4.16	16.1	4.20	16.5	4.22	16.9	4.24
	31	11.8	2.97	14.1	3.83	15.4	4.30	15.6	4.32	15.9	4.36	16.3	4.38	16.7	4.40
	33	11.8	3.16	14.1	4.08	15.2	4.46	15.4	4.49	15.6	4.52	16.0	4.54	16.4	4.56
	35	11.8	3.36	14.1	4.35	14.9	4.63	15.1	4.65	15.4	4.69	15.8	4.71	16.2	4.72
37	11.8	3.51	14.1	4.46	14.7	4.71	14.9	4.74	15.1	4.76	15.5	4.79	16.0	4.80	
39	11.8	3.66	14.0	4.57	14.4	4.79	14.7	4.83	14.9	4.84	15.3	4.87	15.7	4.89	
110	10	10.8	1.58	12.9	1.92	15.0	2.28	16.0	2.47	17.1	2.66	18.4	2.77	18.8	2.78
	12	10.8	1.62	12.9	1.99	15.0	2.38	16.0	2.54	17.1	2.76	18.2	2.87	18.5	2.91
	14	10.8	1.68	12.9	2.07	15.0	2.48	16.0	2.66	17.1	2.90	17.9	2.98	18.3	3.04
	16	10.8	1.74	12.9	2.15	15.0	2.59	16.0	2.78	17.1	3.07	17.7	3.15	18.1	3.17
	18	10.8	1.80	12.9	2.24	15.0	2.73	16.0	2.96	17.1	3.25	17.4	3.31	17.9	3.32
	20	10.8	1.86	12.9	2.35	15.0	2.90	16.0	3.16	16.8	3.43	17.2	3.47	17.6	3.48
	21	10.8	1.90	12.9	2.42	15.0	3.00	16.0	3.27	16.7	3.51	17.1	3.55	17.5	3.56
	23	10.8	2.03	12.9	2.60	15.0	3.22	16.0	3.47	16.5	3.68	16.9	3.71	17.2	3.72
	25	10.8	2.17	12.9	2.77	15.0	3.45	16.0	3.68	16.2	3.83	16.6	3.87	17.0	3.89
	27	10.8	2.32	12.9	2.96	15.0	3.69	15.8	3.88	16.0	4.01	16.4	4.03	16.8	4.05
	29	10.8	2.47	12.9	3.16	15.0	3.94	15.6	4.05	15.8	4.17	16.1	4.19	16.6	4.21
	31	10.8	2.63	12.9	3.37	15.0	4.21	15.3	4.22	15.5	4.34	15.9	4.35	16.3	4.37
	33	10.8	2.80	12.9	3.59	14.9	4.44	15.1	4.41	15.3	4.50	15.7	4.52	16.1	4.53
	35	10.8	2.98	12.9	3.83	14.6	4.60	14.8	4.62	15.1	4.66	15.4	4.68	15.8	4.70
37	10.8	3.10	12.9	3.95	14.4	4.68	14.6	4.69	14.8	4.73	15.2	4.76	15.6	4.77	
39	10.8	3.21	12.9	4.06	14.2	4.75	14.4	4.76	14.6	4.80	14.9	4.83	15.4	4.84	
100	10	9.5	1.42	11.3	1.72	13.1	2.05	14.0	2.21	14.9	2.38	16.8	2.64	18.4	2.67
	12	9.5	1.46	11.3	1.79	13.1	2.11	14.0	2.27	14.9	2.45	16.8	2.79	18.2	2.81
	14	9.5	1.51	11.3	1.87	13.1	2.20	14.0	2.37	14.9	2.56	16.8	2.94	18.0	2.97
	16	9.5	1.56	11.3	1.93	13.1	2.30	14.0	2.48	14.9	2.69	16.8	3.08	17.7	3.13
	18	9.5	1.60	11.3	2.00	13.1	2.39	14.0	2.60	14.9	2.86	16.8	3.26	17.5	3.28
	20	9.5	1.66	11.3	2.08	13.1	2.53	14.0	2.79	14.9	3.06	16.8	3.41	17.2	3.44
	21	9.5	1.69	11.3	2.13	13.1	2.61	14.0	2.88	14.9	3.17	16.8	3.49	17.1	3.52
	23	9.5	1.79	11.3	2.27	13.1	2.80	14.0	3.09	14.9	3.40	16.5	3.66	16.9	3.69
	25	9.5	1.91	11.3	2.42	13.1	3.00	14.0	3.31	14.9	3.63	16.3	3.81	16.6	3.84
	27	9.5	2.04	11.3	2.59	13.1	3.21	14.0	3.54	14.9	3.86	16.0	3.99	16.4	4.02
	29	9.5	2.17	11.3	2.76	13.1	3.42	14.0	3.78	14.9	4.09	15.8	4.15	16.2	4.19
	31	9.5	2.32	11.3	2.94	13.1	3.65	14.0	4.03	14.9	4.29	15.6	4.31	15.9	4.35
	33	9.5	2.46	11.3	3.14	13.1	3.89	14.0	4.30	14.9	4.46	15.3	4.47	15.7	4.51
	35	9.5	2.61	11.3	3.34	13.1	4.15	14.0	4.59	14.7	4.62	15.1	4.64	15.4	4.67
37	9.5	2.72	11.3	3.47	13.1	4.26	14.0	4.67	14.4	4.69	14.8	4.71	15.2	4.75	
39	9.5	2.82	11.3	3.61	13.1	4.38	14.0	4.74	14.2	4.77	14.6	4.78	15.0	4.83	

6. Capacity Tables

Combination (%)	Outdoor Air Temp. (°C DB)	Indoor Air Temp. (DB/WB, °C)													
		20		23		26		27		28		30		32	
		14		16		18		19		20		22		24	
		TC	PI	TC	PI	TC	PI	TC	PI	TC	PI	TC	PI	TC	PI
90	10	8.5	1.42	10.2	1.72	11.8	2.05	12.6	2.21	13.4	2.38	15.1	2.64	16.7	2.67
	12	8.5	1.46	10.2	1.79	11.8	2.11	12.6	2.27	13.4	2.45	15.1	2.79	16.7	2.81
	14	8.5	1.51	10.2	1.87	11.8	2.20	12.6	2.37	13.4	2.56	15.1	2.94	16.7	2.97
	16	8.5	1.56	10.2	1.93	11.8	2.30	12.6	2.48	13.4	2.69	15.1	3.08	16.7	3.13
	18	8.5	1.60	10.2	2.00	11.8	2.39	12.6	2.60	13.4	2.86	15.1	3.23	16.7	3.28
	20	8.5	1.66	10.2	2.08	11.8	2.53	12.6	2.74	13.4	3.00	15.1	3.41	16.7	3.44
	21	8.5	1.69	10.2	2.13	11.8	2.58	12.6	2.83	13.4	3.10	15.1	3.49	16.7	3.52
	23	8.5	1.79	10.2	2.25	11.8	2.76	12.6	3.04	13.4	3.32	15.1	3.66	16.5	3.69
	25	8.5	1.91	10.2	2.40	11.8	2.95	12.6	3.24	13.4	3.55	15.1	3.81	16.2	3.84
	27	8.5	2.04	10.2	2.56	11.8	3.14	12.6	3.46	13.4	3.80	15.1	3.99	16.0	4.02
	29	8.5	2.16	10.2	2.73	11.8	3.36	12.6	3.70	13.4	4.06	15.1	4.15	15.8	4.19
	31	8.5	2.30	10.2	2.91	11.8	3.58	12.6	3.94	13.4	4.29	15.1	4.31	15.5	4.35
	33	8.5	2.45	10.2	3.09	11.8	3.82	12.6	4.20	13.4	4.46	15.1	4.47	15.3	4.51
	35	8.5	2.60	10.2	3.28	11.8	4.06	12.6	4.48	13.4	4.62	14.8	4.64	15.0	4.67
37	8.5	2.72	10.2	3.47	11.8	4.26	12.6	4.67	13.4	4.69	14.6	4.71	14.8	4.75	
39	8.5	2.82	10.2	3.61	11.8	4.38	12.6	4.74	13.4	4.77	14.3	4.78	14.6	4.83	
80	10	7.6	1.42	9.0	1.72	10.5	2.02	11.2	2.18	12.0	2.34	13.4	2.64	14.9	2.67
	12	7.6	1.46	9.0	1.74	10.5	2.06	11.2	2.22	12.0	2.38	13.4	2.72	14.9	2.81
	14	7.6	1.48	9.0	1.78	10.5	2.09	11.2	2.26	12.0	2.42	13.4	2.77	14.9	2.97
	16	7.6	1.50	9.0	1.81	10.5	2.13	11.2	2.30	12.0	2.47	13.4	2.83	14.9	3.07
	18	7.6	1.53	9.0	1.84	10.5	2.17	11.2	2.34	12.0	2.52	13.4	2.88	14.9	3.14
	20	7.6	1.56	9.0	1.88	10.5	2.22	11.2	2.39	12.0	2.57	13.4	2.99	14.9	3.36
	21	7.6	1.57	9.0	1.90	10.5	2.24	11.2	2.42	12.0	2.63	13.4	3.08	14.9	3.48
	23	7.6	1.60	9.0	1.93	10.5	2.34	11.2	2.57	12.0	2.81	13.4	3.25	14.9	3.69
	25	7.6	1.66	9.0	2.06	10.5	2.51	11.2	2.75	12.0	3.01	13.4	3.48	14.9	3.84
	27	7.6	1.76	9.0	2.19	10.5	2.68	11.2	2.94	12.0	3.21	13.4	3.70	14.9	4.02
	29	7.6	1.87	9.0	2.34	10.5	2.85	11.2	3.13	12.0	3.43	13.4	3.97	14.9	4.19
	31	7.6	1.99	9.0	2.48	10.5	3.04	11.2	3.34	12.0	3.65	13.4	4.21	14.9	4.35
	33	7.6	2.11	9.0	2.65	10.5	3.24	11.2	3.56	12.0	3.88	13.4	4.43	14.9	4.51
	35	7.6	2.24	9.0	2.81	10.5	3.45	11.2	3.79	12.0	4.14	13.4	4.64	14.7	4.67
37	7.6	2.37	9.0	2.99	10.5	3.66	11.2	4.02	12.0	4.40	13.4	4.71	14.5	4.75	
39	7.6	2.51	9.0	3.16	10.5	3.87	11.2	4.24	12.0	4.68	13.4	4.78	14.2	4.83	
70	10	6.6	1.20	7.9	1.43	9.2	1.65	9.8	1.79	10.5	1.91	11.7	2.17	13.0	2.43
	12	6.6	1.22	7.9	1.45	9.2	1.69	9.8	1.81	10.5	1.95	11.7	2.21	13.0	2.48
	14	6.6	1.24	7.9	1.46	9.2	1.72	9.8	1.84	10.5	1.97	11.7	2.26	13.0	2.52
	16	6.6	1.26	7.9	1.49	9.2	1.75	9.8	1.88	10.5	2.01	11.7	2.30	13.0	2.58
	18	6.6	1.28	7.9	1.52	9.2	1.79	9.8	1.92	10.5	2.05	11.7	2.33	13.0	2.62
	20	6.6	1.29	7.9	1.55	9.2	1.81	9.8	1.96	10.5	2.10	11.7	2.39	13.0	2.72
	21	6.6	1.31	7.9	1.56	9.2	1.83	9.8	1.97	10.5	2.12	11.7	2.43	13.0	2.81
	23	6.6	1.33	7.9	1.60	9.2	1.87	9.8	2.04	10.5	2.22	11.7	2.60	13.0	2.96
	25	6.6	1.35	7.9	1.65	9.2	1.99	9.8	2.18	10.5	2.37	11.7	2.78	13.0	3.17
	27	6.6	1.43	7.9	1.77	9.2	2.13	9.8	2.31	10.5	2.53	11.7	2.97	13.0	3.37
	29	6.6	1.52	7.9	1.87	9.2	2.26	9.8	2.47	10.5	2.69	11.7	3.16	13.0	3.61
	31	6.6	1.62	7.9	1.99	9.2	2.41	9.8	2.64	10.5	2.87	11.7	3.37	13.0	3.83
	33	6.6	1.71	7.9	2.11	9.2	2.56	9.8	2.80	10.5	3.05	11.7	3.59	13.0	4.04
	35	6.6	1.80	7.9	2.25	9.2	2.72	9.8	2.98	10.5	3.25	11.7	3.83	13.0	4.28
37	6.6	1.92	7.9	2.38	9.2	2.89	9.8	3.16	10.5	3.46	11.7	4.07	13.0	4.52	
39	6.6	2.02	7.9	2.51	9.2	3.06	9.8	3.34	10.5	3.66	11.7	4.31	13.0	4.73	
60	10	5.7	0.98	6.8	1.15	7.9	1.34	8.4	1.44	9.0	1.53	10.1	1.73	11.2	1.94
	12	5.7	1.00	6.8	1.17	7.9	1.36	8.4	1.46	9.0	1.55	10.1	1.76	11.2	1.97
	14	5.7	1.01	6.8	1.19	7.9	1.38	8.4	1.48	9.0	1.58	10.1	1.80	11.2	2.01
	16	5.7	1.03	6.8	1.21	7.9	1.40	8.4	1.51	9.0	1.62	10.1	1.83	11.2	2.05
	18	5.7	1.05	6.8	1.23	7.9	1.43	8.4	1.54	9.0	1.64	10.1	1.86	11.2	2.09
	20	5.7	1.06	6.8	1.25	7.9	1.46	8.4	1.56	9.0	1.67	10.1	1.89	11.2	2.14
	21	5.7	1.07	6.8	1.26	7.9	1.47	8.4	1.58	9.0	1.69	10.1	1.92	11.2	2.15
	23	5.7	1.09	6.8	1.29	7.9	1.49	8.4	1.61	9.0	1.72	10.1	1.99	11.2	2.29
	25	5.7	1.11	6.8	1.31	7.9	1.55	8.4	1.69	9.0	1.83	10.1	2.13	11.2	2.45
	27	5.7	1.14	6.8	1.38	7.9	1.65	8.4	1.80	9.0	1.95	10.1	2.26	11.2	2.61
	29	5.7	1.21	6.8	1.47	7.9	1.76	8.4	1.91	9.0	2.07	10.1	2.41	11.2	2.79
	31	5.7	1.29	6.8	1.56	7.9	1.87	8.4	2.04	9.0	2.21	10.1	2.57	11.2	2.97
	33	5.7	1.36	6.8	1.65	7.9	1.98	8.4	2.16	9.0	2.35	10.1	2.73	11.2	3.16
	35	5.7	1.44	6.8	1.76	7.9	2.11	8.4	2.30	9.0	2.49	10.1	2.91	11.2	3.36
37	5.7	1.52	6.8	1.86	7.9	2.23	8.4	2.44	9.0	2.64	10.1	3.09	11.2	3.57	
39	5.7	1.60	6.8	1.96	7.9	2.36	8.4	2.59	9.0	2.79	10.1	3.28	11.2	3.79	

6. Capacity Tables

Combination (%)	Outdoor Air Temp. (°C DB)	Indoor Air Temp. (DB/WB, °C)													
		20		23		26		27		28		30		32	
		14		16		18		19		20		22		24	
		TC	PI	TC	PI	TC	PI	TC	PI	TC	PI	TC	PI	TC	PI
50	10	4.7	0.80	5.7	0.93	6.6	1.05	7.0	1.13	7.5	1.20	8.4	1.35	9.3	1.50
	12	4.7	0.81	5.7	0.93	6.6	1.07	7.0	1.15	7.5	1.22	8.4	1.37	9.3	1.52
	14	4.7	0.82	5.7	0.95	6.6	1.09	7.0	1.16	7.5	1.24	8.4	1.39	9.3	1.55
	16	4.7	0.83	5.7	0.97	6.6	1.10	7.0	1.19	7.5	1.25	8.4	1.41	9.3	1.57
	18	4.7	0.84	5.7	0.98	6.6	1.12	7.0	1.20	7.5	1.28	8.4	1.44	9.3	1.61
	20	4.7	0.85	5.7	0.99	6.6	1.15	7.0	1.22	7.5	1.30	8.4	1.46	9.3	1.64
	21	4.7	0.86	5.7	1.00	6.6	1.15	7.0	1.24	7.5	1.31	8.4	1.48	9.3	1.66
	23	4.7	0.88	5.7	1.02	6.6	1.17	7.0	1.25	7.5	1.34	8.4	1.51	9.3	1.69
	25	4.7	0.88	5.7	1.04	6.6	1.20	7.0	1.28	7.5	1.38	8.4	1.58	9.3	1.81
	27	4.7	0.90	5.7	1.07	6.6	1.26	7.0	1.36	7.5	1.46	8.4	1.69	9.3	1.93
	29	4.7	0.95	5.7	1.14	6.6	1.34	7.0	1.45	7.5	1.56	8.4	1.79	9.3	2.05
	31	4.7	1.00	5.7	1.20	6.6	1.42	7.0	1.53	7.5	1.66	8.4	1.91	9.3	2.18
	33	4.7	1.06	5.7	1.27	6.6	1.51	7.0	1.62	7.5	1.76	8.4	2.03	9.3	2.32
	35	4.7	1.12	5.7	1.35	6.6	1.59	7.0	1.73	7.5	1.86	8.4	2.15	9.3	2.47
	37	4.7	1.19	5.7	1.42	6.6	1.68	7.0	1.83	7.5	1.97	8.4	2.29	9.3	2.62
39	4.7	1.24	5.7	1.50	6.6	1.79	7.0	1.93	7.5	2.07	8.4	2.41	9.3	2.77	

Note

1. TC: Total Capacity(kW), PI : Power Input(kW, Comp. + Outdoor fan motor)
2. Capacity tables show the average value of conditions which may occur.

6. Capacity Tables

◆ ARUN060LSS0

Combination (%)	Outdoor Air Temp. (°C DB)	Indoor Air Temp. (DB/WB, °C)													
		20		23		26		27		28		30		32	
		14		16		18		19		20		22		24	
		TC	PI	TC	PI	TC	PI	TC	PI	TC	PI	TC	PI	TC	PI
130	10	14.2	2.19	16.9	2.68	19.6	3.11	20.3	3.17	20.6	3.21	21.1	3.22	21.6	3.24
	12	14.2	2.25	16.9	2.78	19.6	3.24	20.0	3.26	20.4	3.32	20.8	3.35	21.3	3.37
	14	14.2	2.32	16.9	2.88	19.5	3.36	19.8	3.38	20.0	3.44	20.6	3.47	21.1	3.50
	16	14.2	2.41	16.9	2.98	19.3	3.51	19.5	3.54	19.8	3.57	20.3	3.60	20.8	3.63
	18	14.2	2.51	16.9	3.15	19.0	3.70	19.2	3.73	19.5	3.75	20.0	3.77	20.6	3.79
	20	14.2	2.62	16.9	3.36	18.7	3.88	19.0	3.91	19.2	3.93	19.8	3.95	20.3	3.98
	21	14.2	2.69	16.9	3.47	18.6	3.96	18.9	4.00	19.1	4.02	19.6	4.04	20.2	4.07
	23	14.2	2.88	16.9	3.73	18.4	4.13	18.6	4.17	18.9	4.21	19.4	4.23	19.9	4.25
	25	14.2	3.08	16.9	3.98	18.1	4.32	18.4	4.36	18.6	4.39	19.1	4.41	19.6	4.44
	27	14.2	3.30	16.9	4.26	17.9	4.51	18.1	4.54	18.4	4.57	18.9	4.60	19.4	4.62
	29	14.2	3.51	16.9	4.55	17.6	4.69	17.8	4.72	18.1	4.76	18.6	4.78	19.1	4.81
	31	14.2	3.75	16.8	4.79	17.3	4.88	17.6	4.91	17.8	4.94	18.3	4.96	18.8	4.99
	33	14.2	3.99	16.5	4.98	17.1	5.06	17.3	5.10	17.6	5.12	18.1	5.15	18.5	5.18
	35	14.2	4.26	16.2	5.16	16.8	5.25	17.1	5.28	17.3	5.30	17.8	5.33	18.3	5.36
37	14.2	4.41	16.0	5.26	16.5	5.35	16.8	5.40	17.1	5.42	17.5	5.43	18.0	5.47	
39	14.2	4.56	15.7	5.36	16.2	5.46	16.5	5.50	16.8	5.52	17.3	5.54	17.8	5.58	
120	10	13.1	1.97	15.6	2.42	18.1	2.87	19.4	3.11	20.3	3.16	20.8	3.17	21.2	3.18
	12	13.1	2.03	15.6	2.50	18.1	2.99	19.4	3.17	20.0	3.27	20.5	3.31	21.0	3.33
	14	13.1	2.10	15.6	2.59	18.1	3.11	19.4	3.29	19.7	3.39	20.3	3.44	20.7	3.47
	16	13.1	2.17	15.6	2.69	18.1	3.23	19.3	3.47	19.5	3.55	20.0	3.56	20.4	3.60
	18	13.1	2.26	15.6	2.81	18.1	3.43	19.0	3.66	19.2	3.73	19.7	3.75	20.2	3.76
	20	13.1	2.34	15.6	2.98	18.1	3.65	18.8	3.88	19.0	3.91	19.5	3.93	19.9	3.95
	21	13.1	2.41	15.6	3.09	18.1	3.78	18.6	3.96	18.8	4.00	19.3	4.02	19.8	4.04
	23	13.1	2.58	15.6	3.31	18.1	4.03	18.4	4.14	18.6	4.19	19.0	4.20	19.5	4.22
	25	13.1	2.76	15.6	3.54	17.8	4.25	18.1	4.33	18.3	4.37	18.8	4.39	19.3	4.40
	27	13.1	2.94	15.6	3.79	17.6	4.47	17.8	4.50	18.1	4.55	18.5	4.57	19.0	4.59
	29	13.1	3.14	15.6	4.04	17.3	4.65	17.5	4.69	17.8	4.73	18.2	4.75	18.8	4.77
	31	13.1	3.35	15.6	4.32	17.0	4.85	17.3	4.87	17.5	4.91	18.0	4.93	18.5	4.95
	33	13.1	3.56	15.6	4.60	16.8	5.02	17.0	5.05	17.3	5.10	17.7	5.12	18.2	5.14
	35	13.1	3.79	15.6	4.91	16.5	5.22	16.7	5.24	17.0	5.28	17.5	5.30	17.9	5.32
37	13.1	3.95	15.6	5.03	16.3	5.31	16.5	5.34	16.7	5.36	17.2	5.40	17.7	5.41	
39	13.1	4.12	15.5	5.15	16.0	5.40	16.2	5.44	16.4	5.45	17.0	5.49	17.4	5.50	
110	10	12.0	1.77	14.3	2.16	16.6	2.57	17.8	2.78	18.9	2.99	20.4	3.12	20.8	3.13
	12	12.0	1.83	14.3	2.24	16.6	2.68	17.8	2.86	18.9	3.11	20.1	3.23	20.5	3.28
	14	12.0	1.89	14.3	2.34	16.6	2.80	17.8	3.00	18.9	3.26	19.8	3.35	20.3	3.43
	16	12.0	1.95	14.3	2.42	16.6	2.91	17.8	3.13	18.9	3.46	19.6	3.54	20.0	3.57
	18	12.0	2.03	14.3	2.52	16.6	3.08	17.8	3.34	18.9	3.66	19.3	3.72	19.8	3.74
	20	12.0	2.10	14.3	2.65	16.6	3.27	17.8	3.56	18.6	3.87	19.1	3.91	19.5	3.92
	21	12.0	2.15	14.3	2.73	16.6	3.38	17.8	3.69	18.5	3.95	18.9	4.00	19.4	4.01
	23	12.0	2.29	14.3	2.92	16.6	3.63	17.8	3.91	18.2	4.14	18.7	4.18	19.1	4.19
	25	12.0	2.44	14.3	3.12	16.6	3.88	17.8	4.14	18.0	4.32	18.4	4.36	18.8	4.38
	27	12.0	2.61	14.3	3.34	16.6	4.16	17.5	4.37	17.7	4.52	18.2	4.54	18.6	4.56
	29	12.0	2.79	14.3	3.56	16.6	4.43	17.2	4.56	17.5	4.70	17.9	4.72	18.3	4.74
	31	12.0	2.96	14.3	3.80	16.6	4.74	16.9	4.76	17.2	4.88	17.6	4.90	18.0	4.92
	33	12.0	3.16	14.3	4.04	16.5	5.00	16.7	4.97	16.9	5.07	17.4	5.09	17.8	5.11
	35	12.0	3.36	14.3	4.32	16.2	5.18	16.4	5.20	16.7	5.25	17.1	5.27	17.5	5.29
37	12.0	3.49	14.3	4.45	16.0	5.27	16.2	5.28	16.4	5.32	16.8	5.36	17.2	5.37	
39	12.0	3.62	14.3	4.58	15.7	5.36	15.9	5.36	16.1	5.41	16.5	5.44	17.0	5.45	
100	10	10.5	1.60	12.5	1.94	14.5	2.30	15.5	2.49	16.5	2.68	18.5	2.98	20.4	3.00
	12	10.5	1.65	12.5	2.02	14.5	2.38	15.5	2.56	16.5	2.76	18.5	3.14	20.1	3.17
	14	10.5	1.70	12.5	2.10	14.5	2.48	15.5	2.67	16.5	2.88	18.5	3.31	19.9	3.34
	16	10.5	1.75	12.5	2.17	14.5	2.59	15.5	2.79	16.5	3.03	18.5	3.47	19.6	3.52
	18	10.5	1.80	12.5	2.25	14.5	2.69	15.5	2.93	16.5	3.22	18.5	3.67	19.3	3.70
	20	10.5	1.87	12.5	2.34	14.5	2.84	15.5	3.14	16.5	3.44	18.5	3.85	19.0	3.88
	21	10.5	1.91	12.5	2.39	14.5	2.94	15.5	3.25	16.5	3.57	18.5	3.93	18.9	3.97
	23	10.5	2.02	12.5	2.56	14.5	3.16	15.5	3.48	16.5	3.83	18.3	4.12	18.7	4.15
	25	10.5	2.15	12.5	2.73	14.5	3.37	15.5	3.73	16.5	4.09	18.0	4.29	18.4	4.33
	27	10.5	2.30	12.5	2.91	14.5	3.61	15.5	3.98	16.5	4.35	17.8	4.50	18.2	4.53
	29	10.5	2.44	12.5	3.11	14.5	3.86	15.5	4.26	16.5	4.60	17.5	4.68	17.9	4.72
	31	10.5	2.61	12.5	3.32	14.5	4.11	15.5	4.54	16.5	4.84	17.2	4.86	17.6	4.90
	33	10.5	2.77	12.5	3.53	14.5	4.39	15.5	4.85	16.5	5.02	17.0	5.04	17.3	5.08
	35	10.5	2.94	12.5	3.76	14.5	4.67	15.5	5.17	16.2	5.20	16.7	5.22	17.1	5.26
37	10.5	3.06	12.5	3.91	14.5	4.80	15.5	5.26	16.0	5.28	16.4	5.31	16.8	5.35	
39	10.5	3.18	12.5	4.07	14.5	4.93	15.5	5.34	15.7	5.37	16.2	5.39	16.6	5.44	

6. Capacity Tables

Combination (%)	Outdoor Air Temp. (°C DB)	Indoor Air Temp. (DB/WB, °C)													
		20		23		26		27		28		30		32	
		14		16		18		19		20		22		24	
		TC	PI	TC	PI	TC	PI	TC	PI	TC	PI	TC	PI	TC	PI
90	10	9.4	1.60	11.2	1.94	13.1	2.30	14.0	2.49	14.8	2.68	16.7	2.98	18.5	3.00
	12	9.4	1.65	11.2	2.02	13.1	2.38	14.0	2.56	14.8	2.76	16.7	3.14	18.5	3.17
	14	9.4	1.70	11.2	2.10	13.1	2.48	14.0	2.67	14.8	2.88	16.7	3.31	18.5	3.34
	16	9.4	1.75	11.2	2.17	13.1	2.59	14.0	2.79	14.8	3.03	16.7	3.47	18.5	3.52
	18	9.4	1.80	11.2	2.25	13.1	2.69	14.0	2.93	14.8	3.20	16.7	3.58	18.5	3.70
	20	9.4	1.87	11.2	2.34	13.1	2.80	14.0	3.03	14.8	3.32	16.7	3.83	18.5	3.88
	21	9.4	1.91	11.2	2.39	13.1	2.85	14.0	3.13	14.8	3.44	16.7	3.93	18.5	3.97
	23	9.4	2.02	11.2	2.49	13.1	3.05	14.0	3.36	14.8	3.68	16.7	4.12	18.2	4.15
	25	9.4	2.12	11.2	2.66	13.1	3.26	14.0	3.59	14.8	3.93	16.7	4.29	18.0	4.33
	27	9.4	2.26	11.2	2.83	13.1	3.48	14.0	3.83	14.8	4.21	16.7	4.50	17.7	4.53
	29	9.4	2.39	11.2	3.02	13.1	3.72	14.0	4.10	14.8	4.50	16.7	4.68	17.4	4.72
	31	9.4	2.55	11.2	3.22	13.1	3.97	14.0	4.36	14.8	4.79	16.7	4.86	17.2	4.90
	33	9.4	2.71	11.2	3.43	13.1	4.23	14.0	4.65	14.8	5.02	16.7	5.04	16.9	5.08
	35	9.4	2.88	11.2	3.64	13.1	4.50	14.0	4.96	14.8	5.20	16.4	5.22	16.7	5.26
37	9.4	3.05	11.2	3.87	13.1	4.79	14.0	5.26	14.8	5.28	16.1	5.31	16.4	5.35	
39	9.4	3.18	11.2	4.07	13.1	4.93	14.0	5.34	14.8	5.37	15.8	5.39	16.1	5.44	
80	10	8.4	1.59	10.0	1.91	11.6	2.24	12.4	2.42	13.2	2.59	14.8	2.96	16.4	3.00
	12	8.4	1.62	10.0	1.93	11.6	2.28	12.4	2.46	13.2	2.64	14.8	3.01	16.4	3.17
	14	8.4	1.64	10.0	1.97	11.6	2.32	12.4	2.50	13.2	2.68	14.8	3.07	16.4	3.34
	16	8.4	1.67	10.0	2.01	11.6	2.36	12.4	2.55	13.2	2.74	14.8	3.13	16.4	3.40
	18	8.4	1.70	10.0	2.04	11.6	2.40	12.4	2.59	13.2	2.79	14.8	3.19	16.4	3.47
	20	8.4	1.73	10.0	2.08	11.6	2.46	12.4	2.65	13.2	2.85	14.8	3.31	16.4	3.72
	21	8.4	1.74	10.0	2.11	11.6	2.48	12.4	2.68	13.2	2.91	14.8	3.41	16.4	3.86
	23	8.4	1.78	10.0	2.14	11.6	2.59	12.4	2.85	13.2	3.11	14.8	3.60	16.4	4.13
	25	8.4	1.84	10.0	2.28	11.6	2.78	12.4	3.04	13.2	3.33	14.8	3.86	16.4	4.33
	27	8.4	1.95	10.0	2.43	11.6	2.97	12.4	3.25	13.2	3.55	14.8	4.10	16.4	4.53
	29	8.4	2.07	10.0	2.59	11.6	3.15	12.4	3.46	13.2	3.79	14.8	4.39	16.4	4.72
	31	8.4	2.21	10.0	2.75	11.6	3.36	12.4	3.69	13.2	4.04	14.8	4.66	16.4	4.90
	33	8.4	2.34	10.0	2.93	11.6	3.58	12.4	3.94	13.2	4.30	14.8	4.91	16.4	5.08
	35	8.4	2.48	10.0	3.11	11.6	3.82	12.4	4.19	13.2	4.59	14.8	5.21	16.3	5.26
37	8.4	2.62	10.0	3.31	11.6	4.05	12.4	4.46	13.2	4.87	14.8	5.31	16.0	5.35	
39	8.4	2.77	10.0	3.50	11.6	4.29	12.4	4.70	13.2	5.19	14.8	5.39	15.7	5.44	
70	10	7.3	1.33	8.7	1.58	10.1	1.83	10.9	1.98	11.6	2.11	13.0	2.41	14.4	2.69
	12	7.3	1.35	8.7	1.60	10.1	1.87	10.9	2.01	11.6	2.15	13.0	2.45	14.4	2.74
	14	7.3	1.37	8.7	1.62	10.1	1.90	10.9	2.04	11.6	2.19	13.0	2.50	14.4	2.79
	16	7.3	1.39	8.7	1.65	10.1	1.94	10.9	2.08	11.6	2.23	13.0	2.54	14.4	2.85
	18	7.3	1.41	8.7	1.68	10.1	1.98	10.9	2.12	11.6	2.27	13.0	2.58	14.4	2.90
	20	7.3	1.43	8.7	1.72	10.1	2.01	10.9	2.17	11.6	2.32	13.0	2.65	14.4	3.01
	21	7.3	1.45	8.7	1.73	10.1	2.03	10.9	2.19	11.6	2.34	13.0	2.69	14.4	3.11
	23	7.3	1.47	8.7	1.77	10.1	2.07	10.9	2.26	11.6	2.46	13.0	2.88	14.4	3.28
	25	7.3	1.50	8.7	1.83	10.1	2.21	10.9	2.42	11.6	2.63	13.0	3.08	14.4	3.51
	27	7.3	1.58	8.7	1.96	10.1	2.35	10.9	2.56	11.6	2.80	13.0	3.28	14.4	3.73
	29	7.3	1.68	8.7	2.07	10.1	2.50	10.9	2.73	11.6	2.98	13.0	3.50	14.4	4.00
	31	7.3	1.79	8.7	2.21	10.1	2.67	10.9	2.92	11.6	3.18	13.0	3.73	14.4	4.24
	33	7.3	1.89	8.7	2.33	10.1	2.83	10.9	3.10	11.6	3.38	13.0	3.97	14.4	4.47
	35	7.3	2.00	8.7	2.49	10.1	3.01	10.9	3.29	11.6	3.60	13.0	4.24	14.4	4.74
37	7.3	2.12	8.7	2.64	10.1	3.20	10.9	3.50	11.6	3.83	13.0	4.51	14.4	5.00	
39	7.3	2.23	8.7	2.78	10.1	3.39	10.9	3.70	11.6	4.05	13.0	4.78	14.4	5.23	
60	10	6.3	1.09	7.5	1.28	8.7	1.48	9.3	1.59	9.9	1.69	11.1	1.92	12.3	2.15
	12	6.3	1.11	7.5	1.30	8.7	1.50	9.3	1.61	9.9	1.72	11.1	1.95	12.3	2.19
	14	6.3	1.12	7.5	1.32	8.7	1.53	9.3	1.64	9.9	1.75	11.1	1.99	12.3	2.23
	16	6.3	1.14	7.5	1.35	8.7	1.55	9.3	1.67	9.9	1.79	11.1	2.03	12.3	2.26
	18	6.3	1.16	7.5	1.36	8.7	1.58	9.3	1.70	9.9	1.82	11.1	2.06	12.3	2.31
	20	6.3	1.18	7.5	1.38	8.7	1.61	9.3	1.73	9.9	1.85	11.1	2.10	12.3	2.36
	21	6.3	1.19	7.5	1.39	8.7	1.63	9.3	1.75	9.9	1.87	11.1	2.13	12.3	2.38
	23	6.3	1.21	7.5	1.42	8.7	1.65	9.3	1.78	9.9	1.91	11.1	2.21	12.3	2.53
	25	6.3	1.23	7.5	1.45	8.7	1.72	9.3	1.87	9.9	2.03	11.1	2.35	12.3	2.71
	27	6.3	1.27	7.5	1.53	8.7	1.83	9.3	1.99	9.9	2.16	11.1	2.50	12.3	2.89
	29	6.3	1.35	7.5	1.63	8.7	1.95	9.3	2.12	9.9	2.29	11.1	2.67	12.3	3.09
	31	6.3	1.42	7.5	1.73	8.7	2.07	9.3	2.25	9.9	2.44	11.1	2.85	12.3	3.28
	33	6.3	1.50	7.5	1.83	8.7	2.20	9.3	2.39	9.9	2.60	11.1	3.03	12.3	3.50
	35	6.3	1.59	7.5	1.95	8.7	2.33	9.3	2.54	9.9	2.76	11.1	3.22	12.3	3.72
37	6.3	1.68	7.5	2.06	8.7	2.47	9.3	2.70	9.9	2.93	11.1	3.42	12.3	3.96	
39	6.3	1.77	7.5	2.17	8.7	2.62	9.3	2.87	9.9	3.09	11.1	3.63	12.3	4.20	

6. Capacity Tables

Combination (%)	Outdoor Air Temp. (°C DB)	Indoor Air Temp. (DB/WB, °C)													
		20		23		26		27		28		30		32	
		14		16		18		19		20		22		24	
		TC	PI	TC	PI	TC	PI	TC	PI	TC	PI	TC	PI	TC	PI
50	10	5.2	0.89	6.3	1.03	7.3	1.17	7.8	1.25	8.2	1.32	9.2	1.49	10.3	1.66
	12	5.2	0.89	6.3	1.03	7.3	1.18	7.8	1.27	8.2	1.35	9.2	1.52	10.3	1.69
	14	5.2	0.90	6.3	1.05	7.3	1.20	7.8	1.29	8.2	1.37	9.2	1.54	10.3	1.72
	16	5.2	0.92	6.3	1.07	7.3	1.22	7.8	1.31	8.2	1.39	9.2	1.57	10.3	1.74
	18	5.2	0.93	6.3	1.08	7.3	1.24	7.8	1.33	8.2	1.42	9.2	1.59	10.3	1.78
	20	5.2	0.94	6.3	1.10	7.3	1.27	7.8	1.35	8.2	1.44	9.2	1.62	10.3	1.82
	21	5.2	0.95	6.3	1.11	7.3	1.28	7.8	1.37	8.2	1.45	9.2	1.64	10.3	1.84
	23	5.2	0.97	6.3	1.13	7.3	1.30	7.8	1.39	8.2	1.48	9.2	1.67	10.3	1.87
	25	5.2	0.98	6.3	1.15	7.3	1.32	7.8	1.42	8.2	1.53	9.2	1.75	10.3	2.00
	27	5.2	1.00	6.3	1.18	7.3	1.40	7.8	1.51	8.2	1.62	9.2	1.87	10.3	2.13
	29	5.2	1.05	6.3	1.26	7.3	1.48	7.8	1.60	8.2	1.72	9.2	1.99	10.3	2.27
	31	5.2	1.11	6.3	1.33	7.3	1.58	7.8	1.70	8.2	1.84	9.2	2.12	10.3	2.41
	33	5.2	1.17	6.3	1.41	7.3	1.67	7.8	1.80	8.2	1.95	9.2	2.25	10.3	2.57
	35	5.2	1.24	6.3	1.49	7.3	1.76	7.8	1.91	8.2	2.06	9.2	2.38	10.3	2.73
	37	5.2	1.31	6.3	1.58	7.3	1.86	7.8	2.02	8.2	2.18	9.2	2.54	10.3	2.90
39	5.2	1.37	6.3	1.66	7.3	1.98	7.8	2.13	8.2	2.29	9.2	2.67	10.3	3.07	

Note

1. TC: Total Capacity(kW), PI : Power Input(kW, Comp. + Outdoor fan motor)
2. Capacity tables show the average value of conditions which may occur.

6. Capacity Tables

◆ ARUN080LSS0

Combination (%)	Outdoor Air Temp. (°C DB)	Indoor Air Temp. (DB/WB, °C)													
		20		23		26		27		28		30		32	
		14		16		18		19		20		22		24	
		TC	PI	TC	PI	TC	PI	TC	PI	TC	PI	TC	PI	TC	PI
130	10	20.5	3.58	24.4	4.38	28.3	5.08	29.4	5.19	29.7	5.24	30.5	5.27	31.2	5.30
	12	20.5	3.67	24.4	4.54	28.3	5.29	29.0	5.33	29.5	5.43	30.1	5.48	30.8	5.51
	14	20.5	3.80	24.4	4.70	28.2	5.49	28.6	5.53	29.0	5.62	29.7	5.68	30.5	5.72
	16	20.5	3.93	24.4	4.87	27.9	5.74	28.2	5.79	28.6	5.83	29.3	5.89	30.1	5.94
	18	20.5	4.10	24.4	5.15	27.5	6.04	27.8	6.09	28.2	6.13	29.0	6.16	29.7	6.20
	20	20.5	4.28	24.4	5.48	27.1	6.33	27.5	6.39	27.8	6.43	28.6	6.46	29.3	6.50
	21	20.5	4.39	24.4	5.68	26.9	6.48	27.3	6.54	27.6	6.58	28.4	6.61	29.1	6.65
	23	20.5	4.71	24.4	6.09	26.6	6.75	26.9	6.82	27.3	6.88	28.0	6.91	28.7	6.95
	25	20.5	5.03	24.4	6.51	26.1	7.06	26.6	7.13	26.9	7.18	27.6	7.21	28.4	7.26
	27	20.5	5.39	24.4	6.96	25.8	7.36	26.1	7.42	26.6	7.47	27.3	7.51	28.0	7.56
	29	20.5	5.74	24.4	7.44	25.4	7.67	25.8	7.72	26.1	7.77	26.9	7.81	27.6	7.86
	31	20.5	6.13	24.3	7.84	25.0	7.97	25.4	8.03	25.8	8.07	26.5	8.11	27.2	8.16
	33	20.5	6.53	23.9	8.14	24.6	8.28	25.0	8.33	25.4	8.37	26.1	8.41	26.8	8.46
	35	20.5	6.96	23.5	8.43	24.2	8.58	24.6	8.63	25.0	8.67	25.7	8.71	26.5	8.77
37	20.5	7.20	23.1	8.59	23.9	8.75	24.2	8.82	24.6	8.85	25.3	8.88	26.1	8.95	
39	20.5	7.45	22.7	8.76	23.5	8.92	23.9	8.99	24.2	9.02	25.0	9.05	25.7	9.12	
120	10	18.9	3.22	22.5	3.95	26.2	4.70	28.0	5.08	29.4	5.16	30.0	5.18	30.7	5.20
	12	18.9	3.31	22.5	4.09	26.2	4.89	28.0	5.19	29.0	5.35	29.6	5.41	30.3	5.44
	14	18.9	3.43	22.5	4.23	26.2	5.09	28.0	5.38	28.5	5.55	29.3	5.63	30.0	5.68
	16	18.9	3.55	22.5	4.40	26.2	5.28	27.9	5.67	28.2	5.80	28.9	5.82	29.5	5.89
	18	18.9	3.69	22.5	4.60	26.2	5.60	27.5	5.99	27.8	6.10	28.5	6.12	29.2	6.15
	20	18.9	3.83	22.5	4.87	26.2	5.97	27.1	6.33	27.5	6.40	28.1	6.42	28.8	6.45
	21	18.9	3.94	22.5	5.05	26.2	6.18	26.9	6.48	27.2	6.55	28.0	6.57	28.6	6.60
	23	18.9	4.22	22.5	5.40	26.2	6.59	26.5	6.77	26.9	6.84	27.5	6.87	28.2	6.90
	25	18.9	4.51	22.5	5.79	25.8	6.95	26.1	7.07	26.4	7.14	27.2	7.17	27.9	7.20
	27	18.9	4.81	22.5	6.19	25.4	7.30	25.8	7.36	26.1	7.44	26.8	7.47	27.5	7.50
	29	18.9	5.13	22.5	6.61	25.0	7.61	25.4	7.66	25.7	7.74	26.4	7.77	27.1	7.80
	31	18.9	5.47	22.5	7.06	24.6	7.92	25.0	7.95	25.4	8.03	26.0	8.06	26.7	8.10
	33	18.9	5.82	22.5	7.52	24.3	8.21	24.6	8.26	24.9	8.33	25.6	8.36	26.3	8.40
	35	18.9	6.19	22.5	8.02	23.9	8.53	24.2	8.56	24.6	8.63	25.3	8.66	25.9	8.70
37	18.9	6.46	22.5	8.21	23.5	8.67	23.9	8.73	24.2	8.76	24.9	8.82	25.5	8.84	
39	18.9	6.74	22.4	8.41	23.1	8.83	23.4	8.89	23.8	8.91	24.5	8.97	25.2	9.00	
110	10	17.3	2.90	20.7	3.54	24.0	4.20	25.7	4.55	27.3	4.89	29.4	5.09	30.1	5.11
	12	17.3	2.99	20.7	3.65	24.0	4.37	25.7	4.67	27.3	5.08	29.1	5.29	29.7	5.36
	14	17.3	3.08	20.7	3.82	24.0	4.57	25.7	4.91	27.3	5.33	28.7	5.48	29.3	5.60
	16	17.3	3.19	20.7	3.96	24.0	4.76	25.7	5.12	27.3	5.66	28.3	5.79	28.9	5.83
	18	17.3	3.31	20.7	4.12	24.0	5.03	25.7	5.46	27.3	5.99	27.9	6.09	28.6	6.11
	20	17.3	3.43	20.7	4.33	24.0	5.34	25.7	5.82	26.9	6.32	27.6	6.38	28.2	6.41
	21	17.3	3.51	20.7	4.46	24.0	5.53	25.7	6.02	26.7	6.46	27.3	6.53	28.0	6.56
	23	17.3	3.74	20.7	4.78	24.0	5.93	25.7	6.39	26.3	6.77	27.0	6.83	27.6	6.86
	25	17.3	3.99	20.7	5.10	24.0	6.35	25.7	6.77	26.0	7.06	26.6	7.13	27.2	7.15
	27	17.3	4.27	20.7	5.45	24.0	6.80	25.2	7.14	25.6	7.39	26.2	7.42	26.8	7.45
	29	17.3	4.55	20.7	5.82	24.0	7.25	24.9	7.45	25.2	7.68	25.8	7.72	26.5	7.75
	31	17.3	4.84	20.7	6.21	24.0	7.74	24.5	7.78	24.8	7.98	25.5	8.02	26.1	8.05
	33	17.3	5.16	20.7	6.61	23.8	8.18	24.2	8.12	24.5	8.28	25.1	8.31	25.7	8.35
	35	17.3	5.48	20.7	7.06	23.4	8.47	23.7	8.50	24.1	8.58	24.7	8.61	25.3	8.64
37	17.3	5.70	20.7	7.27	23.1	8.62	23.4	8.63	23.7	8.70	24.3	8.75	24.9	8.78	
39	17.3	5.92	20.7	7.48	22.7	8.75	23.0	8.77	23.3	8.84	23.9	8.89	24.6	8.91	
100	10	15.1	2.61	18.0	3.17	21.0	3.77	22.4	4.07	23.8	4.37	26.8	4.87	29.4	4.91
	12	15.1	2.70	18.0	3.30	21.0	3.89	22.4	4.18	23.8	4.51	26.8	5.13	29.0	5.18
	14	15.1	2.78	18.0	3.44	21.0	4.06	22.4	4.36	23.8	4.71	26.8	5.42	28.7	5.47
	16	15.1	2.86	18.0	3.55	21.0	4.23	22.4	4.57	23.8	4.96	26.8	5.68	28.3	5.76
	18	15.1	2.95	18.0	3.68	21.0	4.39	22.4	4.79	23.8	5.26	26.8	6.00	27.9	6.05
	20	15.1	3.05	18.0	3.82	21.0	4.65	22.4	5.13	23.8	5.63	26.8	6.29	27.5	6.34
	21	15.1	3.12	18.0	3.91	21.0	4.81	22.4	5.31	23.8	5.84	26.8	6.43	27.4	6.48
	23	15.1	3.30	18.0	4.18	21.0	5.16	22.4	5.69	23.8	6.25	26.4	6.73	27.0	6.79
	25	15.1	3.51	18.0	4.46	21.0	5.52	22.4	6.09	23.8	6.69	26.0	7.02	26.6	7.08
	27	15.1	3.75	18.0	4.76	21.0	5.90	22.4	6.51	23.8	7.11	25.7	7.35	26.2	7.41
	29	15.1	3.99	18.0	5.08	21.0	6.30	22.4	6.96	23.8	7.52	25.3	7.65	25.8	7.71
	31	15.1	4.27	18.0	5.42	21.0	6.72	22.4	7.42	23.8	7.91	24.9	7.94	25.4	8.01
	33	15.1	4.52	18.0	5.77	21.0	7.17	22.4	7.92	23.8	8.20	24.5	8.24	25.0	8.30
	35	15.1	4.81	18.0	6.14	21.0	7.63	22.4	8.45	23.5	8.50	24.1	8.53	24.6	8.60
37	15.1	5.00	18.0	6.39	21.0	7.85	22.4	8.59	23.1	8.64	23.8	8.67	24.3	8.75	
39	15.1	5.19	18.0	6.65	21.0	8.06	22.4	8.73	22.7	8.77	23.4	8.81	23.9	8.89	

6. Capacity Tables

Combination (%)	Outdoor Air Temp. (°C DB)	Indoor Air Temp. (DB/WB, °C)													
		20		23		26		27		28		30		32	
		14		16		18		19		20		22		24	
		TC	PI	TC	PI	TC	PI	TC	PI	TC	PI	TC	PI	TC	PI
90	10	13.6	2.60	16.2	3.12	18.9	3.68	20.2	3.96	21.4	4.27	24.1	4.78	26.7	4.91
	12	13.6	2.63	16.2	3.17	18.9	3.74	20.2	4.04	21.4	4.36	24.1	4.87	26.7	5.18
	14	13.6	2.68	16.2	3.23	18.9	3.82	20.2	4.12	21.4	4.44	24.1	4.97	26.7	5.47
	16	13.6	2.72	16.2	3.30	18.9	3.90	20.2	4.20	21.4	4.52	24.1	5.06	26.7	5.61
	18	13.6	2.77	16.2	3.36	18.9	3.96	20.2	4.30	21.4	4.62	24.1	5.17	26.7	5.89
	20	13.6	2.82	16.2	3.42	18.9	4.04	20.2	4.38	21.4	4.79	24.1	5.53	26.7	6.17
	21	13.6	2.85	16.2	3.46	18.9	4.12	20.2	4.52	21.4	4.97	24.1	5.74	26.7	6.31
	23	13.6	2.91	16.2	3.60	18.9	4.41	20.2	4.86	21.4	5.32	24.1	6.15	26.4	6.61
	25	13.6	3.06	16.2	3.84	18.9	4.71	20.2	5.19	21.4	5.68	24.1	6.57	26.0	6.89
	27	13.6	3.26	16.2	4.09	18.9	5.03	20.2	5.54	21.4	6.08	24.1	6.99	25.6	7.22
	29	13.6	3.46	16.2	4.36	18.9	5.38	20.2	5.92	21.4	6.50	24.1	7.48	25.2	7.51
	31	13.6	3.68	16.2	4.65	18.9	5.73	20.2	6.31	21.4	6.93	24.1	7.77	24.8	7.80
	33	13.6	3.92	16.2	4.95	18.9	6.11	20.2	6.72	21.4	7.35	24.1	8.06	24.4	8.09
	35	13.6	4.16	16.2	5.25	18.9	6.50	20.2	7.17	21.4	7.79	23.7	8.36	24.1	8.38
	37	13.6	4.41	16.2	5.59	18.9	6.93	20.2	7.61	21.4	8.22	23.3	8.65	23.7	8.67
39	13.6	4.67	16.2	5.94	18.9	7.33	20.2	8.02	21.4	8.65	22.9	8.81	23.3	8.89	
80	10	12.1	2.30	14.4	2.76	16.7	3.24	17.9	3.49	19.1	3.75	21.4	4.27	23.8	4.64
	12	12.1	2.34	14.4	2.79	16.7	3.30	17.9	3.55	19.1	3.81	21.4	4.35	23.8	4.73
	14	12.1	2.37	14.4	2.85	16.7	3.35	17.9	3.62	19.1	3.87	21.4	4.43	23.8	4.82
	16	12.1	2.41	14.4	2.90	16.7	3.41	17.9	3.68	19.1	3.95	21.4	4.53	23.8	4.91
	18	12.1	2.45	14.4	2.95	16.7	3.47	17.9	3.75	19.1	4.03	21.4	4.61	23.8	5.02
	20	12.1	2.50	14.4	3.01	16.7	3.55	17.9	3.83	19.1	4.11	21.4	4.78	23.8	5.37
	21	12.1	2.52	14.4	3.04	16.7	3.59	17.9	3.87	19.1	4.21	21.4	4.93	23.8	5.57
	23	12.1	2.57	14.4	3.09	16.7	3.75	17.9	4.11	19.1	4.49	21.4	5.21	23.8	5.97
	25	12.1	2.66	14.4	3.30	16.7	4.02	17.9	4.40	19.1	4.81	21.4	5.57	23.8	6.38
	27	12.1	2.82	14.4	3.51	16.7	4.29	17.9	4.70	19.1	5.13	21.4	5.92	23.8	6.79
	29	12.1	3.00	14.4	3.75	16.7	4.56	17.9	5.00	19.1	5.48	21.4	6.34	23.8	7.26
	31	12.1	3.19	14.4	3.97	16.7	4.86	17.9	5.34	19.1	5.83	21.4	6.73	23.8	7.55
	33	12.1	3.38	14.4	4.24	16.7	5.18	17.9	5.69	19.1	6.22	21.4	7.09	23.8	7.83
	35	12.1	3.59	14.4	4.49	16.7	5.51	17.9	6.06	19.1	6.63	21.4	7.52	23.5	8.11
	37	12.1	3.79	14.4	4.78	16.7	5.85	17.9	6.44	19.1	7.04	21.4	7.94	23.1	8.40
39	12.1	4.01	14.4	5.05	16.7	6.20	17.9	6.79	19.1	7.50	21.4	8.30	22.7	8.68	
70	10	10.6	1.92	12.6	2.28	14.6	2.65	15.7	2.86	16.7	3.05	18.7	3.48	20.8	3.89
	12	10.6	1.95	12.6	2.31	14.6	2.71	15.7	2.90	16.7	3.11	18.7	3.54	20.8	3.96
	14	10.6	1.98	12.6	2.34	14.6	2.75	15.7	2.95	16.7	3.16	18.7	3.61	20.8	4.03
	16	10.6	2.01	12.6	2.39	14.6	2.80	15.7	3.01	16.7	3.22	18.7	3.67	20.8	4.12
	18	10.6	2.04	12.6	2.43	14.6	2.86	15.7	3.07	16.7	3.28	18.7	3.73	20.8	4.19
	20	10.6	2.07	12.6	2.48	14.6	2.90	15.7	3.13	16.7	3.36	18.7	3.82	20.8	4.35
	21	10.6	2.10	12.6	2.49	14.6	2.93	15.7	3.16	16.7	3.39	18.7	3.88	20.8	4.49
	23	10.6	2.13	12.6	2.55	14.6	2.99	15.7	3.26	16.7	3.55	18.7	4.16	20.8	4.74
	25	10.6	2.16	12.6	2.65	14.6	3.19	15.7	3.49	16.7	3.79	18.7	4.44	20.8	5.07
	27	10.6	2.28	12.6	2.83	14.6	3.40	15.7	3.70	16.7	4.05	18.7	4.75	20.8	5.39
	29	10.6	2.43	12.6	2.99	14.6	3.61	15.7	3.95	16.7	4.31	18.7	5.06	20.8	5.78
	31	10.6	2.58	12.6	3.19	14.6	3.85	15.7	4.22	16.7	4.60	18.7	5.40	20.8	6.13
	33	10.6	2.74	12.6	3.37	14.6	4.10	15.7	4.47	16.7	4.88	18.7	5.74	20.8	6.46
	35	10.6	2.89	12.6	3.60	14.6	4.35	15.7	4.76	16.7	5.20	18.7	6.12	20.8	6.85
	37	10.6	3.07	12.6	3.81	14.6	4.63	15.7	5.06	16.7	5.53	18.7	6.51	20.8	7.23
39	10.6	3.23	12.6	4.02	14.6	4.90	15.7	5.34	16.7	5.86	18.7	6.90	20.8	7.56	
60	10	9.0	1.57	10.8	1.84	12.6	2.14	13.4	2.30	14.3	2.44	16.1	2.77	17.8	3.10
	12	9.0	1.60	10.8	1.87	12.6	2.17	13.4	2.33	14.3	2.49	16.1	2.82	17.8	3.16
	14	9.0	1.62	10.8	1.90	12.6	2.22	13.4	2.37	14.3	2.53	16.1	2.87	17.8	3.22
	16	9.0	1.64	10.8	1.94	12.6	2.24	13.4	2.42	14.3	2.59	16.1	2.93	17.8	3.27
	18	9.0	1.67	10.8	1.97	12.6	2.29	13.4	2.46	14.3	2.63	16.1	2.97	17.8	3.34
	20	9.0	1.70	10.8	2.00	12.6	2.33	13.4	2.50	14.3	2.67	16.1	3.03	17.8	3.42
	21	9.0	1.72	10.8	2.02	12.6	2.36	13.4	2.53	14.3	2.70	16.1	3.07	17.8	3.44
	23	9.0	1.74	10.8	2.06	12.6	2.39	13.4	2.57	14.3	2.76	16.1	3.19	17.8	3.66
	25	9.0	1.77	10.8	2.10	12.6	2.49	13.4	2.70	14.3	2.93	16.1	3.40	17.8	3.92
	27	9.0	1.83	10.8	2.22	12.6	2.64	13.4	2.87	14.3	3.12	16.1	3.62	17.8	4.17
	29	9.0	1.94	10.8	2.36	12.6	2.82	13.4	3.06	14.3	3.32	16.1	3.86	17.8	4.46
	31	9.0	2.06	10.8	2.50	12.6	2.99	13.4	3.26	14.3	3.53	16.1	4.12	17.8	4.75
	33	9.0	2.17	10.8	2.64	12.6	3.17	13.4	3.46	14.3	3.76	16.1	4.37	17.8	5.06
	35	9.0	2.30	10.8	2.82	12.6	3.37	13.4	3.67	14.3	3.99	16.1	4.66	17.8	5.37
	37	9.0	2.43	10.8	2.97	12.6	3.57	13.4	3.90	14.3	4.23	16.1	4.95	17.8	5.72
39	9.0	2.56	10.8	3.13	12.6	3.78	13.4	4.15	14.3	4.46	16.1	5.25	17.8	6.07	

6. Capacity Tables

Combination (%)	Outdoor Air Temp. (°C DB)	Indoor Air Temp. (DB/WB, °C)													
		20		23		26		27		28		30		32	
		14		16		18		19		20		22		24	
		TC	PI	TC	PI	TC	PI	TC	PI	TC	PI	TC	PI	TC	PI
50	10	7.6	1.28	9.0	1.48	10.5	1.68	11.2	1.81	11.9	1.91	13.4	2.16	14.9	2.40
	12	7.6	1.29	9.0	1.50	10.5	1.71	11.2	1.83	11.9	1.95	13.4	2.20	14.9	2.44
	14	7.6	1.31	9.0	1.52	10.5	1.74	11.2	1.86	11.9	1.98	13.4	2.22	14.9	2.48
	16	7.6	1.33	9.0	1.55	10.5	1.76	11.2	1.90	11.9	2.01	13.4	2.26	14.9	2.52
	18	7.6	1.35	9.0	1.56	10.5	1.79	11.2	1.93	11.9	2.05	13.4	2.30	14.9	2.57
	20	7.6	1.36	9.0	1.59	10.5	1.83	11.2	1.95	11.9	2.09	13.4	2.34	14.9	2.63
	21	7.6	1.37	9.0	1.60	10.5	1.85	11.2	1.98	11.9	2.10	13.4	2.37	14.9	2.65
	23	7.6	1.40	9.0	1.63	10.5	1.87	11.2	2.01	11.9	2.14	13.4	2.41	14.9	2.71
	25	7.6	1.41	9.0	1.66	10.5	1.91	11.2	2.05	11.9	2.21	13.4	2.53	14.9	2.90
	27	7.6	1.44	9.0	1.71	10.5	2.02	11.2	2.18	11.9	2.34	13.4	2.71	14.9	3.08
	29	7.6	1.52	9.0	1.82	10.5	2.14	11.2	2.32	11.9	2.49	13.4	2.87	14.9	3.27
	31	7.6	1.60	9.0	1.93	10.5	2.28	11.2	2.45	11.9	2.65	13.4	3.06	14.9	3.49
	33	7.6	1.70	9.0	2.03	10.5	2.41	11.2	2.60	11.9	2.82	13.4	3.25	14.9	3.72
	35	7.6	1.79	9.0	2.16	10.5	2.55	11.2	2.76	11.9	2.98	13.4	3.44	14.9	3.95
	37	7.6	1.90	9.0	2.28	10.5	2.69	11.2	2.92	11.9	3.15	13.4	3.66	14.9	4.19
39	7.6	1.99	9.0	2.39	10.5	2.86	11.2	3.08	11.9	3.32	13.4	3.86	14.9	4.44	

Note

1. TC: Total Capacity(kW), PI : Power Input(kW, Comp. + Outdoor fan motor)
2. Capacity tables show the average value of conditions which may occur.

6. Capacity Tables

◆ ARUN100LSS0

Combination (%)	Outdoor Air Temp. (°C DB)	Indoor Air Temp. (DB/WB, °C)													
		20		23		26		27		28		30		32	
		14		16		18		19		20		22		24	
		TC	PI	TC	PI	TC	PI	TC	PI	TC	PI	TC	PI	TC	PI
130	10	25.6	5.28	30.5	6.45	35.4	7.48	36.7	7.63	37.2	7.72	38.1	7.75	39.0	7.80
	12	25.6	5.41	30.5	6.68	35.4	7.79	36.2	7.84	36.8	7.99	37.6	8.07	38.5	8.11
	14	25.6	5.59	30.5	6.92	35.3	8.08	35.8	8.14	36.2	8.28	37.2	8.36	38.1	8.42
	16	25.6	5.79	30.5	7.16	34.9	8.44	35.3	8.52	35.7	8.58	36.6	8.66	37.6	8.74
	18	25.6	6.04	30.5	7.58	34.3	8.90	34.8	8.97	35.3	9.02	36.2	9.07	37.2	9.12
	20	25.6	6.30	30.5	8.07	33.8	9.32	34.4	9.41	34.8	9.46	35.7	9.51	36.6	9.57
	21	25.6	6.47	30.5	8.36	33.6	9.54	34.1	9.63	34.6	9.68	35.5	9.73	36.4	9.79
	23	25.6	6.94	30.5	8.97	33.2	9.94	33.6	10.04	34.1	10.12	35.0	10.17	35.9	10.24
	25	25.6	7.41	30.5	9.58	32.7	10.39	33.2	10.49	33.6	10.56	34.6	10.62	35.5	10.68
	27	25.6	7.93	30.5	10.24	32.3	10.84	32.7	10.92	33.2	11.00	34.1	11.06	35.0	11.13
	29	25.6	8.45	30.5	10.95	31.7	11.29	32.2	11.37	32.7	11.44	33.6	11.50	34.6	11.57
	31	25.6	9.02	30.4	11.54	31.2	11.74	31.7	11.82	32.2	11.88	33.1	11.94	34.0	12.02
	33	25.6	9.61	29.9	11.98	30.8	12.18	31.3	12.26	31.7	12.32	32.7	12.39	33.5	12.46
	35	25.6	10.24	29.3	12.42	30.3	12.63	30.8	12.71	31.3	12.76	32.2	12.83	33.1	12.91
37	25.6	10.61	28.9	12.65	29.9	12.88	30.3	12.98	30.8	13.03	31.6	13.07	32.6	13.17	
39	25.6	10.97	28.4	12.90	29.3	13.14	29.9	13.23	30.3	13.28	31.2	13.32	32.2	13.42	
120	10	23.7	4.75	28.2	5.82	32.7	6.92	35.0	7.48	36.7	7.59	37.5	7.62	38.4	7.65
	12	23.7	4.88	28.2	6.02	32.7	7.20	35.0	7.63	36.2	7.87	37.0	7.97	37.9	8.00
	14	23.7	5.04	28.2	6.22	32.7	7.49	35.0	7.92	35.7	8.16	36.6	8.28	37.4	8.36
	16	23.7	5.23	28.2	6.48	32.7	7.78	34.8	8.34	35.3	8.54	36.1	8.58	36.9	8.67
	18	23.7	5.43	28.2	6.77	32.7	8.25	34.3	8.81	34.7	8.98	35.6	9.02	36.5	9.05
	20	23.7	5.64	28.2	7.18	32.7	8.78	33.9	9.32	34.3	9.42	35.1	9.45	36.0	9.49
	21	23.7	5.81	28.2	7.44	32.7	9.10	33.6	9.54	34.0	9.64	34.9	9.67	35.8	9.71
	23	23.7	6.21	28.2	7.95	32.7	9.70	33.2	9.96	33.6	10.07	34.4	10.11	35.3	10.15
	25	23.7	6.63	28.2	8.52	32.2	10.23	32.6	10.41	33.1	10.51	34.0	10.55	34.8	10.60
	27	23.7	7.08	28.2	9.11	31.8	10.75	32.2	10.83	32.6	10.95	33.5	10.99	34.3	11.04
	29	23.7	7.55	28.2	9.73	31.3	11.20	31.7	11.28	32.1	11.39	33.0	11.43	33.9	11.48
	31	23.7	8.05	28.2	10.39	30.8	11.66	31.3	11.71	31.7	11.83	32.5	11.87	33.4	11.92
	33	23.7	8.57	28.2	11.07	30.4	12.09	30.8	12.16	31.2	12.26	32.0	12.31	32.9	12.36
	35	23.7	9.11	28.2	11.80	29.8	12.56	30.2	12.61	30.8	12.70	31.6	12.75	32.4	12.80
37	23.7	9.52	28.2	12.09	29.4	12.77	29.8	12.85	30.2	12.90	31.1	12.98	31.9	13.02	
39	23.7	9.92	28.1	12.38	28.9	12.99	29.3	13.08	29.7	13.12	30.7	13.21	31.5	13.24	
110	10	21.7	4.27	25.8	5.20	30.0	6.18	32.1	6.69	34.2	7.20	36.8	7.50	37.6	7.53
	12	21.7	4.40	25.8	5.38	30.0	6.44	32.1	6.88	34.2	7.47	36.4	7.78	37.1	7.89
	14	21.7	4.54	25.8	5.62	30.0	6.73	32.1	7.22	34.2	7.85	35.8	8.07	36.7	8.24
	16	21.7	4.70	25.8	5.83	30.0	7.01	32.1	7.54	34.2	8.33	35.4	8.52	36.1	8.58
	18	21.7	4.88	25.8	6.07	30.0	7.41	32.1	8.04	34.2	8.81	34.9	8.96	35.7	9.00
	20	21.7	5.05	25.8	6.37	30.0	7.86	32.1	8.56	33.6	9.30	34.5	9.40	35.2	9.44
	21	21.7	5.16	25.8	6.56	30.0	8.14	32.1	8.87	33.4	9.51	34.2	9.62	35.0	9.66
	23	21.7	5.50	25.8	7.03	30.0	8.73	32.1	9.41	32.9	9.96	33.7	10.05	34.5	10.09
	25	21.7	5.88	25.8	7.51	30.0	9.35	32.1	9.97	32.5	10.39	33.2	10.49	34.1	10.53
	27	21.7	6.28	25.8	8.03	30.0	10.01	31.6	10.52	32.0	10.88	32.8	10.93	33.5	10.97
	29	21.7	6.70	25.8	8.57	30.0	10.67	31.1	10.96	31.6	11.31	32.3	11.36	33.1	11.41
	31	21.7	7.13	25.8	9.14	30.0	11.40	30.6	11.45	31.0	11.75	31.9	11.80	32.6	11.85
	33	21.7	7.60	25.8	9.73	29.8	12.04	30.2	11.96	30.6	12.19	31.4	12.24	32.2	12.29
	35	21.7	8.07	25.8	10.39	29.3	12.46	29.7	12.51	30.1	12.63	30.8	12.68	31.7	12.73
37	21.7	8.39	25.8	10.70	28.9	12.68	29.3	12.70	29.6	12.81	30.4	12.89	31.1	12.93	
39	21.7	8.71	25.8	11.02	28.3	12.89	28.7	12.91	29.2	13.01	29.9	13.09	30.7	13.12	
100	10	18.9	3.85	22.5	4.67	26.2	5.54	28.0	5.99	29.8	6.44	33.5	7.17	36.8	7.22
	12	18.9	3.97	22.5	4.86	26.2	5.73	28.0	6.15	29.8	6.64	33.5	7.55	36.3	7.63
	14	18.9	4.09	22.5	5.06	26.2	5.97	28.0	6.42	29.8	6.93	33.5	7.97	35.9	8.05
	16	18.9	4.22	22.5	5.23	26.2	6.23	28.0	6.72	29.8	7.30	33.5	8.36	35.4	8.48
	18	18.9	4.34	22.5	5.42	26.2	6.47	28.0	7.05	29.8	7.74	33.5	8.83	34.9	8.90
	20	18.9	4.50	22.5	5.63	26.2	6.85	28.0	7.55	29.8	8.29	33.5	9.25	34.4	9.33
	21	18.9	4.59	22.5	5.76	26.2	7.08	28.0	7.81	29.8	8.59	33.5	9.47	34.2	9.54
	23	18.9	4.86	22.5	6.16	26.2	7.60	28.0	8.38	29.8	9.21	33.0	9.91	33.8	9.99
	25	18.9	5.17	22.5	6.56	26.2	8.12	28.0	8.97	29.8	9.84	32.6	10.33	33.2	10.42
	27	18.9	5.52	22.5	7.01	26.2	8.69	28.0	9.58	29.8	10.47	32.1	10.82	32.8	10.91
	29	18.9	5.88	22.5	7.48	26.2	9.28	28.0	10.24	29.8	11.08	31.6	11.26	32.3	11.35
	31	18.9	6.28	22.5	7.98	26.2	9.89	28.0	10.93	29.8	11.64	31.1	11.69	31.8	11.79
	33	18.9	6.66	22.5	8.50	26.2	10.55	28.0	11.66	29.8	12.08	30.6	12.13	31.3	12.22
	35	18.9	7.08	22.5	9.04	26.2	11.24	28.0	12.44	29.3	12.51	30.2	12.56	30.8	12.66
37	18.9	7.36	22.5	9.41	26.2	11.56	28.0	12.65	28.9	12.71	29.7	12.77	30.4	12.88	
39	18.9	7.64	22.5	9.79	26.2	11.86	28.0	12.86	28.4	12.92	29.2	12.96	29.9	13.09	

6. Capacity Tables

Combination (%)	Outdoor Air Temp. (°C DB)	Indoor Air Temp. (DB/WB, °C)													
		20		23		26		27		28		30		32	
		14		16		18		19		20		22		24	
		TC	PI	TC	PI	TC	PI	TC	PI	TC	PI	TC	PI	TC	PI
90	10	17.0	3.24	20.3	3.90	23.6	4.60	25.2	4.96	26.8	5.33	30.1	5.97	33.4	6.64
	12	17.0	3.28	20.3	3.96	23.6	4.68	25.2	5.06	26.8	5.45	30.1	6.09	33.4	6.76
	14	17.0	3.34	20.3	4.04	23.6	4.78	25.2	5.15	26.8	5.55	30.1	6.21	33.4	6.89
	16	17.0	3.40	20.3	4.12	23.6	4.88	25.2	5.25	26.8	5.65	30.1	6.33	33.4	7.01
	18	17.0	3.46	20.3	4.20	23.6	4.96	25.2	5.37	26.8	5.77	30.1	6.46	33.4	7.36
	20	17.0	3.52	20.3	4.28	23.6	5.06	25.2	5.47	26.8	5.99	30.1	6.92	33.4	7.72
	21	17.0	3.56	20.3	4.32	23.6	5.15	25.2	5.65	26.8	6.21	30.1	7.17	33.4	7.89
	23	17.0	3.64	20.3	4.50	23.6	5.51	25.2	6.07	26.8	6.65	30.1	7.68	32.9	8.27
	25	17.0	3.82	20.3	4.80	23.6	5.89	25.2	6.49	26.8	7.11	30.1	8.22	32.5	8.62
	27	17.0	4.08	20.3	5.12	23.6	6.29	25.2	6.93	26.8	7.60	30.1	8.74	32.0	9.02
	29	17.0	4.32	20.3	5.45	23.6	6.73	25.2	7.40	26.8	8.12	30.1	9.35	31.5	9.39
	31	17.0	4.60	20.3	5.81	23.6	7.17	25.2	7.88	26.8	8.66	30.1	9.72	31.0	9.75
	33	17.0	4.90	20.3	6.19	23.6	7.64	25.2	8.40	26.8	9.18	30.1	10.08	30.6	10.11
	35	17.0	5.19	20.3	6.57	23.6	8.12	25.2	8.96	26.8	9.74	29.6	10.45	30.1	10.48
37	17.0	5.51	20.3	6.99	23.6	8.66	25.2	9.51	26.8	10.28	29.1	10.81	29.6	10.84	
39	17.0	5.84	20.3	7.43	23.6	9.16	25.2	10.02	26.8	10.81	28.6	11.18	29.1	11.20	
80	10	15.1	2.87	18.0	3.45	20.9	4.04	22.4	4.36	23.9	4.68	26.8	5.34	29.7	5.80
	12	15.1	2.93	18.0	3.49	20.9	4.12	22.4	4.44	23.9	4.76	26.8	5.44	29.7	5.91
	14	15.1	2.97	18.0	3.57	20.9	4.18	22.4	4.52	23.9	4.84	26.8	5.54	29.7	6.03
	16	15.1	3.01	18.0	3.63	20.9	4.26	22.4	4.60	23.9	4.94	26.8	5.66	29.7	6.14
	18	15.1	3.07	18.0	3.69	20.9	4.34	22.4	4.68	23.9	5.04	26.8	5.76	29.7	6.28
	20	15.1	3.13	18.0	3.77	20.9	4.44	22.4	4.78	23.9	5.14	26.8	5.98	29.7	6.72
	21	15.1	3.15	18.0	3.81	20.9	4.48	22.4	4.84	23.9	5.26	26.8	6.17	29.7	6.96
	23	15.1	3.21	18.0	3.87	20.9	4.68	22.4	5.14	23.9	5.62	26.8	6.51	29.7	7.46
	25	15.1	3.33	18.0	4.12	20.9	5.02	22.4	5.50	23.9	6.02	26.8	6.97	29.7	7.98
	27	15.1	3.53	18.0	4.38	20.9	5.36	22.4	5.88	23.9	6.42	26.8	7.40	29.7	8.48
	29	15.1	3.75	18.0	4.68	20.9	5.70	22.4	6.26	23.9	6.85	26.8	7.93	29.7	9.08
	31	15.1	3.98	18.0	4.96	20.9	6.08	22.4	6.67	23.9	7.29	26.8	8.42	29.7	9.43
	33	15.1	4.22	18.0	5.30	20.9	6.47	22.4	7.11	23.9	7.77	26.8	8.87	29.7	9.79
	35	15.1	4.48	18.0	5.62	20.9	6.89	22.4	7.57	23.9	8.29	26.8	9.40	29.4	10.14
37	15.1	4.74	18.0	5.97	20.9	7.31	22.4	8.05	23.9	8.81	26.8	9.92	28.9	10.50	
39	15.1	5.01	18.0	6.32	20.9	7.74	22.4	8.48	23.9	9.37	26.8	10.38	28.4	10.85	
70	10	13.2	2.40	15.8	2.85	18.3	3.31	19.6	3.57	20.9	3.82	23.4	4.35	26.0	4.86
	12	13.2	2.44	15.8	2.89	18.3	3.38	19.6	3.63	20.9	3.89	23.4	4.42	26.0	4.95
	14	13.2	2.48	15.8	2.93	18.3	3.44	19.6	3.68	20.9	3.95	23.4	4.52	26.0	5.04
	16	13.2	2.51	15.8	2.99	18.3	3.50	19.6	3.76	20.9	4.02	23.4	4.59	26.0	5.15
	18	13.2	2.55	15.8	3.04	18.3	3.57	19.6	3.84	20.9	4.10	23.4	4.67	26.0	5.24
	20	13.2	2.59	15.8	3.10	18.3	3.63	19.6	3.91	20.9	4.19	23.4	4.78	26.0	5.44
	21	13.2	2.63	15.8	3.12	18.3	3.67	19.6	3.95	20.9	4.23	23.4	4.86	26.0	5.61
	23	13.2	2.66	15.8	3.19	18.3	3.74	19.6	4.08	20.9	4.44	23.4	5.20	26.0	5.93
	25	13.2	2.70	15.8	3.31	18.3	3.99	19.6	4.36	20.9	4.74	23.4	5.56	26.0	6.34
	27	13.2	2.85	15.8	3.53	18.3	4.25	19.6	4.63	20.9	5.06	23.4	5.93	26.0	6.74
	29	13.2	3.04	15.8	3.74	18.3	4.52	19.6	4.93	20.9	5.38	23.4	6.33	26.0	7.22
	31	13.2	3.23	15.8	3.99	18.3	4.82	19.6	5.27	20.9	5.74	23.4	6.75	26.0	7.66
	33	13.2	3.42	15.8	4.21	18.3	5.12	19.6	5.59	20.9	6.10	23.4	7.18	26.0	8.07
	35	13.2	3.61	15.8	4.50	18.3	5.44	19.6	5.95	20.9	6.50	23.4	7.65	26.0	8.56
37	13.2	3.84	15.8	4.76	18.3	5.78	19.6	6.33	20.9	6.92	23.4	8.14	26.0	9.04	
39	13.2	4.03	15.8	5.03	18.3	6.12	19.6	6.68	20.9	7.32	23.4	8.63	26.0	9.45	
60	10	11.3	1.97	13.5	2.30	15.7	2.68	16.8	2.88	17.9	3.06	20.1	3.47	22.3	3.88
	12	11.3	2.00	13.5	2.34	15.7	2.72	16.8	2.91	17.9	3.11	20.1	3.52	22.3	3.95
	14	11.3	2.02	13.5	2.38	15.7	2.77	16.8	2.97	17.9	3.16	20.1	3.59	22.3	4.02
	16	11.3	2.05	13.5	2.43	15.7	2.81	16.8	3.02	17.9	3.23	20.1	3.66	22.3	4.09
	18	11.3	2.09	13.5	2.47	15.7	2.86	16.8	3.07	17.9	3.29	20.1	3.72	22.3	4.18
	20	11.3	2.13	13.5	2.50	15.7	2.91	16.8	3.13	17.9	3.34	20.1	3.79	22.3	4.27
	21	11.3	2.14	13.5	2.52	15.7	2.95	16.8	3.16	17.9	3.38	20.1	3.84	22.3	4.31
	23	11.3	2.18	13.5	2.57	15.7	2.98	16.8	3.22	17.9	3.45	20.1	3.98	22.3	4.57
	25	11.3	2.22	13.5	2.63	15.7	3.11	16.8	3.38	17.9	3.66	20.1	4.25	22.3	4.90
	27	11.3	2.29	13.5	2.77	15.7	3.31	16.8	3.59	17.9	3.89	20.1	4.52	22.3	5.22
	29	11.3	2.43	13.5	2.95	15.7	3.52	16.8	3.82	17.9	4.15	20.1	4.82	22.3	5.57
	31	11.3	2.57	13.5	3.13	15.7	3.73	16.8	4.07	17.9	4.41	20.1	5.15	22.3	5.93
	33	11.3	2.72	13.5	3.31	15.7	3.97	16.8	4.32	17.9	4.70	20.1	5.47	22.3	6.32
	35	11.3	2.88	13.5	3.52	15.7	4.22	16.8	4.59	17.9	4.98	20.1	5.82	22.3	6.72
37	11.3	3.04	13.5	3.71	15.7	4.47	16.8	4.88	17.9	5.29	20.1	6.18	22.3	7.15	
39	11.3	3.20	13.5	3.92	15.7	4.73	16.8	5.18	17.9	5.58	20.1	6.56	22.3	7.58	

6. Capacity Tables

Combination (%)	Outdoor Air Temp. (°C DB)	Indoor Air Temp. (DB/WB, °C)													
		20		23		26		27		28		30		32	
		14		16		18		19		20		22		24	
		TC	PI	TC	PI	TC	PI	TC	PI	TC	PI	TC	PI	TC	PI
50	10	9.5	1.60	11.3	1.85	13.1	2.10	14.0	2.26	14.9	2.39	16.7	2.69	18.6	3.00
	12	9.5	1.62	11.3	1.87	13.1	2.14	14.0	2.29	14.9	2.44	16.7	2.74	18.6	3.05
	14	9.5	1.63	11.3	1.90	13.1	2.17	14.0	2.32	14.9	2.48	16.7	2.78	18.6	3.10
	16	9.5	1.67	11.3	1.94	13.1	2.21	14.0	2.37	14.9	2.51	16.7	2.83	18.6	3.15
	18	9.5	1.68	11.3	1.95	13.1	2.24	14.0	2.41	14.9	2.56	16.7	2.88	18.6	3.22
	20	9.5	1.70	11.3	1.99	13.1	2.29	14.0	2.44	14.9	2.61	16.7	2.93	18.6	3.28
	21	9.5	1.72	11.3	2.00	13.1	2.31	14.0	2.48	14.9	2.63	16.7	2.96	18.6	3.32
	23	9.5	1.75	11.3	2.04	13.1	2.34	14.0	2.51	14.9	2.68	16.7	3.01	18.6	3.38
	25	9.5	1.77	11.3	2.07	13.1	2.39	14.0	2.56	14.9	2.76	16.7	3.17	18.6	3.62
	27	9.5	1.80	11.3	2.14	13.1	2.53	14.0	2.73	14.9	2.93	16.7	3.38	18.6	3.86
	29	9.5	1.90	11.3	2.27	13.1	2.68	14.0	2.90	14.9	3.12	16.7	3.59	18.6	4.09
	31	9.5	2.00	11.3	2.41	13.1	2.85	14.0	3.06	14.9	3.32	16.7	3.82	18.6	4.36
	33	9.5	2.12	11.3	2.54	13.1	3.01	14.0	3.25	14.9	3.52	16.7	4.06	18.6	4.65
	35	9.5	2.24	11.3	2.69	13.1	3.18	14.0	3.45	14.9	3.72	16.7	4.29	18.6	4.93
	37	9.5	2.37	11.3	2.85	13.1	3.37	14.0	3.65	14.9	3.94	16.7	4.58	18.6	5.24
39	9.5	2.48	11.3	2.99	13.1	3.57	14.0	3.86	14.9	4.14	16.7	4.83	18.6	5.55	

Note

1. TC: Total Capacity(kW), PI : Power Input(kW, Comp. + Outdoor fan motor)
2. Capacity tables show the average value of conditions which may occur.

6. Capacity Tables

◆ ARUN120LSS0

Combination (%)	Outdoor Air Temp. (°C DB)	Indoor Air Temp. (DB/WB, °C)													
		20		23		26		27		28		30		32	
		14		16		18		19		20		22		24	
		TC	PI	TC	PI	TC	PI	TC	PI	TC	PI	TC	PI	TC	PI
130	10	30.7	6.48	36.6	7.92	42.5	9.18	44.1	9.37	44.6	9.47	45.7	9.52	46.8	9.58
	12	30.7	6.64	36.6	8.20	42.5	9.56	43.5	9.62	44.2	9.81	45.1	9.91	46.2	9.95
	14	30.7	6.86	36.6	8.50	42.3	9.92	43.0	9.99	43.5	10.16	44.6	10.26	45.7	10.34
	16	30.7	7.11	36.6	8.79	41.8	10.37	42.3	10.46	42.8	10.54	44.0	10.64	45.1	10.73
	18	30.7	7.41	36.6	9.30	41.2	10.92	41.7	11.01	42.3	11.08	43.5	11.13	44.6	11.20
	20	30.7	7.74	36.6	9.91	40.6	11.45	41.3	11.55	41.7	11.62	42.8	11.68	44.0	11.75
	21	30.7	7.94	36.6	10.26	40.3	11.71	41.0	11.83	41.5	11.89	42.6	11.95	43.7	12.02
	23	30.7	8.52	36.6	11.01	39.8	12.21	40.3	12.33	40.9	12.43	42.0	12.49	43.1	12.56
	25	30.7	9.10	36.6	11.76	39.2	12.76	39.9	12.88	40.3	12.97	41.5	13.03	42.6	13.11
	27	30.7	9.74	36.6	12.58	38.7	13.31	39.2	13.40	39.9	13.51	40.9	13.58	42.0	13.66
	29	30.7	10.37	36.6	13.44	38.1	13.86	38.6	13.95	39.2	14.05	40.3	14.12	41.5	14.20
	31	30.7	11.07	36.5	14.16	37.5	14.41	38.1	14.50	38.6	14.59	39.7	14.66	40.8	14.75
	33	30.7	11.79	35.8	14.70	37.0	14.96	37.6	15.05	38.1	15.13	39.2	15.20	40.2	15.30
	35	30.7	12.58	35.2	15.24	36.3	15.51	37.0	15.60	37.6	15.67	38.6	15.75	39.7	15.84
37	30.7	13.02	34.7	15.53	35.8	15.81	36.3	15.94	37.0	16.00	38.0	16.05	39.1	16.17	
39	30.7	13.46	34.1	15.84	35.2	16.13	35.8	16.25	36.3	16.30	37.5	16.35	38.6	16.47	
120	10	28.4	5.83	33.8	7.15	39.3	8.49	42.0	9.18	44.0	9.32	45.0	9.36	46.1	9.40
	12	28.4	5.98	33.8	7.39	39.3	8.83	42.0	9.37	43.4	9.67	44.4	9.78	45.4	9.82
	14	28.4	6.19	33.8	7.64	39.3	9.19	42.0	9.73	42.8	10.02	43.9	10.17	44.9	10.26
	16	28.4	6.41	33.8	7.95	39.3	9.54	41.8	10.24	42.3	10.48	43.3	10.53	44.3	10.64
	18	28.4	6.67	33.8	8.31	39.3	10.12	41.2	10.82	41.7	11.02	42.7	11.07	43.8	11.11
	20	28.4	6.92	33.8	8.81	39.3	10.78	40.7	11.45	41.2	11.56	42.2	11.61	43.2	11.65
	21	28.4	7.13	33.8	9.13	39.3	11.17	40.3	11.71	40.8	11.83	41.9	11.88	42.9	11.92
	23	28.4	7.62	33.8	9.76	39.3	11.91	39.8	12.23	40.3	12.37	41.3	12.42	42.3	12.46
	25	28.4	8.14	33.8	10.46	38.7	12.55	39.2	12.78	39.7	12.90	40.8	12.95	41.8	13.01
	27	28.4	8.69	33.8	11.18	38.2	13.20	38.7	13.30	39.2	13.44	40.2	13.49	41.2	13.55
	29	28.4	9.27	33.8	11.94	37.5	13.75	38.0	13.85	38.5	13.98	39.5	14.03	40.7	14.09
	31	28.4	9.88	33.8	12.75	36.9	14.31	37.5	14.37	38.0	14.52	39.0	14.57	40.0	14.63
	33	28.4	10.52	33.8	13.59	36.4	14.84	36.9	14.92	37.4	15.05	38.4	15.11	39.4	15.17
	35	28.4	11.18	33.8	14.49	35.8	15.41	36.3	15.47	36.9	15.59	37.9	15.65	38.9	15.72
37	28.4	11.68	33.8	14.84	35.3	15.67	35.8	15.78	36.3	15.84	37.3	15.94	38.3	15.98	
39	28.4	12.17	33.7	15.20	34.7	15.95	35.2	16.06	35.7	16.11	36.8	16.21	37.8	16.25	
110	10	26.0	5.24	31.0	6.39	36.0	7.59	38.5	8.21	41.0	8.84	44.1	9.20	45.1	9.24
	12	26.0	5.41	31.0	6.60	36.0	7.90	38.5	8.45	41.0	9.17	43.6	9.55	44.5	9.69
	14	26.0	5.57	31.0	6.90	36.0	8.26	38.5	8.86	41.0	9.63	43.0	9.91	44.0	10.12
	16	26.0	5.77	31.0	7.15	36.0	8.60	38.5	9.25	41.0	10.22	42.5	10.46	43.4	10.54
	18	26.0	5.99	31.0	7.45	36.0	9.10	38.5	9.86	41.0	10.82	41.9	11.00	42.9	11.04
	20	26.0	6.20	31.0	7.82	36.0	9.65	38.5	10.51	40.4	11.42	41.4	11.54	42.2	11.58
	21	26.0	6.34	31.0	8.06	36.0	10.00	38.5	10.89	40.1	11.68	41.0	11.80	42.0	11.85
	23	26.0	6.75	31.0	8.63	36.0	10.72	38.5	11.55	39.5	12.23	40.5	12.34	41.4	12.39
	25	26.0	7.21	31.0	9.21	36.0	11.47	38.5	12.23	39.0	12.75	39.9	12.88	40.9	12.93
	27	26.0	7.71	31.0	9.85	36.0	12.29	37.9	12.91	38.4	13.35	39.4	13.41	40.2	13.47
	29	26.0	8.23	31.0	10.52	36.0	13.10	37.4	13.46	37.9	13.89	38.7	13.95	39.7	14.01
	31	26.0	8.75	31.0	11.21	36.0	14.00	36.7	14.05	37.2	14.42	38.2	14.49	39.1	14.54
	33	26.0	9.33	31.0	11.94	35.7	14.78	36.2	14.68	36.7	14.96	37.6	15.02	38.6	15.08
	35	26.0	9.91	31.0	12.75	35.1	15.30	35.6	15.36	36.1	15.50	37.0	15.56	38.0	15.62
37	26.0	10.30	31.0	13.14	34.6	15.57	35.1	15.59	35.5	15.73	36.5	15.82	37.4	15.87	
39	26.0	10.69	31.0	13.52	34.0	15.82	34.5	15.85	35.0	15.97	35.9	16.06	36.9	16.11	
100	10	22.7	4.72	27.0	5.74	31.4	6.81	33.6	7.35	35.8	7.90	40.2	8.80	44.2	8.87
	12	22.7	4.87	27.0	5.97	31.4	7.04	33.6	7.55	35.8	8.15	40.2	9.27	43.6	9.36
	14	22.7	5.02	27.0	6.21	31.4	7.33	33.6	7.88	35.8	8.51	40.2	9.79	43.1	9.88
	16	22.7	5.18	27.0	6.42	31.4	7.65	33.6	8.25	35.8	8.96	40.2	10.26	42.5	10.40
	18	22.7	5.33	27.0	6.65	31.4	7.94	33.6	8.66	35.8	9.50	40.2	10.84	41.9	10.93
	20	22.7	5.52	27.0	6.91	31.4	8.40	33.6	9.27	35.8	10.17	40.2	11.36	41.3	11.45
	21	22.7	5.63	27.0	7.07	31.4	8.69	33.6	9.59	35.8	10.55	40.2	11.62	41.0	11.71
	23	22.7	5.97	27.0	7.56	31.4	9.33	33.6	10.29	35.8	11.30	39.6	12.17	40.5	12.26
	25	22.7	6.35	27.0	8.06	31.4	9.97	33.6	11.01	35.8	12.08	39.1	12.69	39.8	12.79
	27	22.7	6.78	27.0	8.61	31.4	10.66	33.6	11.76	35.8	12.85	38.5	13.28	39.4	13.39
	29	22.7	7.21	27.0	9.19	31.4	11.39	33.6	12.58	35.8	13.60	37.9	13.82	38.8	13.93
	31	22.7	7.71	27.0	9.79	31.4	12.14	33.6	13.42	35.8	14.29	37.3	14.35	38.2	14.47
	33	22.7	8.17	27.0	10.43	31.4	12.95	33.6	14.31	35.8	14.82	36.8	14.89	37.6	15.01
	35	22.7	8.69	27.0	11.10	31.4	13.79	33.6	15.27	35.2	15.36	36.2	15.42	37.0	15.54
37	22.7	9.04	27.0	11.56	31.4	14.18	33.6	15.53	34.6	15.61	35.6	15.67	36.5	15.82	
39	22.7	9.38	27.0	12.02	31.4	14.56	33.6	15.78	34.1	15.85	35.1	15.91	35.9	16.06	

6. Capacity Tables

Combination (%)	Outdoor Air Temp. (°C DB)	Indoor Air Temp. (DB/WB, °C)													
		20		23		26		27		28		30		32	
		14		16		18		19		20		22		24	
		TC	PI	TC	PI	TC	PI	TC	PI	TC	PI	TC	PI	TC	PI
90	10	20.4	3.89	24.4	4.68	28.3	5.52	30.2	5.95	32.2	6.40	36.1	7.16	40.1	7.97
	12	20.4	3.94	24.4	4.75	28.3	5.61	30.2	6.07	32.2	6.54	36.1	7.31	40.1	8.11
	14	20.4	4.01	24.4	4.85	28.3	5.73	30.2	6.19	32.2	6.66	36.1	7.45	40.1	8.27
	16	20.4	4.08	24.4	4.94	28.3	5.85	30.2	6.31	32.2	6.78	36.1	7.59	40.1	8.41
	18	20.4	4.16	24.4	5.04	28.3	5.95	30.2	6.45	32.2	6.93	36.1	7.76	40.1	8.84
	20	20.4	4.23	24.4	5.14	28.3	6.07	30.2	6.57	32.2	7.19	36.1	8.30	40.1	9.26
	21	20.4	4.28	24.4	5.18	28.3	6.19	30.2	6.78	32.2	7.45	36.1	8.61	40.1	9.47
	23	20.4	4.37	24.4	5.40	28.3	6.62	30.2	7.28	32.2	7.98	36.1	9.22	39.5	9.92
	25	20.4	4.59	24.4	5.76	28.3	7.07	30.2	7.79	32.2	8.53	36.1	9.86	39.0	10.34
	27	20.4	4.90	24.4	6.14	28.3	7.55	30.2	8.31	32.2	9.12	36.1	10.48	38.4	10.83
	29	20.4	5.18	24.4	6.54	28.3	8.07	30.2	8.88	32.2	9.74	36.1	11.22	37.8	11.26
	31	20.4	5.52	24.4	6.97	28.3	8.60	30.2	9.46	32.2	10.39	36.1	11.66	37.2	11.70
	33	20.4	5.88	24.4	7.43	28.3	9.17	30.2	10.08	32.2	11.02	36.1	12.10	36.7	12.14
	35	20.4	6.23	24.4	7.88	28.3	9.74	30.2	10.75	32.2	11.69	35.5	12.54	36.1	12.57
37	20.4	6.62	24.4	8.38	28.3	10.39	30.2	11.42	32.2	12.34	34.9	12.97	35.5	13.01	
39	20.4	7.00	24.4	8.92	28.3	11.00	30.2	12.03	32.2	12.97	34.4	13.41	35.0	13.44	
80	10	18.1	3.44	21.6	4.14	25.1	4.85	26.9	5.24	28.7	5.62	32.2	6.41	35.6	6.96
	12	18.1	3.51	21.6	4.18	25.1	4.95	26.9	5.33	28.7	5.71	32.2	6.53	35.6	7.09
	14	18.1	3.56	21.6	4.28	25.1	5.02	26.9	5.43	28.7	5.81	32.2	6.65	35.6	7.23
	16	18.1	3.61	21.6	4.35	25.1	5.12	26.9	5.52	28.7	5.93	32.2	6.79	35.6	7.37
	18	18.1	3.68	21.6	4.42	25.1	5.21	26.9	5.62	28.7	6.05	32.2	6.91	35.6	7.53
	20	18.1	3.75	21.6	4.52	25.1	5.33	26.9	5.74	28.7	6.17	32.2	7.17	35.6	8.06
	21	18.1	3.78	21.6	4.57	25.1	5.38	26.9	5.81	28.7	6.31	32.2	7.40	35.6	8.36
	23	18.1	3.85	21.6	4.64	25.1	5.62	26.9	6.17	28.7	6.74	32.2	7.81	35.6	8.95
	25	18.1	3.99	21.6	4.95	25.1	6.02	26.9	6.60	28.7	7.22	32.2	8.36	35.6	9.57
	27	18.1	4.23	21.6	5.26	25.1	6.43	26.9	7.05	28.7	7.70	32.2	8.88	35.6	10.18
	29	18.1	4.49	21.6	5.62	25.1	6.84	26.9	7.51	28.7	8.22	32.2	9.52	35.6	10.89
	31	18.1	4.78	21.6	5.95	25.1	7.29	26.9	8.01	28.7	8.75	32.2	10.10	35.6	11.32
	33	18.1	5.07	21.6	6.36	25.1	7.77	26.9	8.53	28.7	9.32	32.2	10.64	35.6	11.75
	35	18.1	5.38	21.6	6.74	25.1	8.27	26.9	9.08	28.7	9.95	32.2	11.28	35.3	12.17
37	18.1	5.69	21.6	7.17	25.1	8.77	26.9	9.66	28.7	10.57	32.2	11.91	34.7	12.60	
39	18.1	6.01	21.6	7.58	25.1	9.29	26.9	10.18	28.7	11.24	32.2	12.46	34.1	13.02	
70	10	15.8	2.88	19.0	3.42	22.0	3.97	23.5	4.29	25.1	4.58	28.1	5.21	31.2	5.83
	12	15.8	2.92	19.0	3.47	22.0	4.06	23.5	4.35	25.1	4.67	28.1	5.31	31.2	5.94
	14	15.8	2.97	19.0	3.51	22.0	4.13	23.5	4.42	25.1	4.74	28.1	5.42	31.2	6.05
	16	15.8	3.02	19.0	3.58	22.0	4.19	23.5	4.51	25.1	4.83	28.1	5.51	31.2	6.18
	18	15.8	3.06	19.0	3.65	22.0	4.29	23.5	4.60	25.1	4.92	28.1	5.60	31.2	6.29
	20	15.8	3.11	19.0	3.72	22.0	4.35	23.5	4.69	25.1	5.03	28.1	5.74	31.2	6.53
	21	15.8	3.15	19.0	3.74	22.0	4.40	23.5	4.74	25.1	5.08	28.1	5.83	31.2	6.74
	23	15.8	3.20	19.0	3.83	22.0	4.49	23.5	4.90	25.1	5.33	28.1	6.24	31.2	7.11
	25	15.8	3.24	19.0	3.97	22.0	4.78	23.5	5.24	25.1	5.69	28.1	6.67	31.2	7.61
	27	15.8	3.42	19.0	4.24	22.0	5.10	23.5	5.56	25.1	6.08	28.1	7.12	31.2	8.09
	29	15.8	3.65	19.0	4.49	22.0	5.42	23.5	5.92	25.1	6.46	28.1	7.60	31.2	8.67
	31	15.8	3.88	19.0	4.78	22.0	5.78	23.5	6.33	25.1	6.89	28.1	8.09	31.2	9.20
	33	15.8	4.10	19.0	5.06	22.0	6.14	23.5	6.71	25.1	7.32	28.1	8.62	31.2	9.69
	35	15.8	4.33	19.0	5.40	22.0	6.53	23.5	7.14	25.1	7.80	28.1	9.18	31.2	10.27
37	15.8	4.60	19.0	5.72	22.0	6.94	23.5	7.60	25.1	8.30	28.1	9.77	31.2	10.84	
39	15.8	4.84	19.0	6.03	22.0	7.35	23.5	8.01	25.1	8.79	28.1	10.35	31.2	11.34	
60	10	13.6	2.36	16.2	2.77	18.8	3.22	20.2	3.45	21.5	3.67	24.1	4.16	26.8	4.65
	12	13.6	2.40	16.2	2.81	18.8	3.26	20.2	3.49	21.5	3.73	24.1	4.22	26.8	4.74
	14	13.6	2.42	16.2	2.85	18.8	3.32	20.2	3.56	21.5	3.79	24.1	4.31	26.8	4.82
	16	13.6	2.47	16.2	2.92	18.8	3.37	20.2	3.62	21.5	3.88	24.1	4.40	26.8	4.91
	18	13.6	2.51	16.2	2.96	18.8	3.43	20.2	3.69	21.5	3.94	24.1	4.46	26.8	5.02
	20	13.6	2.55	16.2	3.00	18.8	3.49	20.2	3.75	21.5	4.01	24.1	4.55	26.8	5.12
	21	13.6	2.57	16.2	3.02	18.8	3.54	20.2	3.79	21.5	4.05	24.1	4.61	26.8	5.17
	23	13.6	2.62	16.2	3.09	18.8	3.58	20.2	3.86	21.5	4.14	24.1	4.78	26.8	5.49
	25	13.6	2.66	16.2	3.15	18.8	3.73	20.2	4.05	21.5	4.40	24.1	5.10	26.8	5.87
	27	13.6	2.74	16.2	3.32	18.8	3.97	20.2	4.31	21.5	4.67	24.1	5.42	26.8	6.26
	29	13.6	2.92	16.2	3.54	18.8	4.22	20.2	4.59	21.5	4.97	24.1	5.79	26.8	6.69
	31	13.6	3.09	16.2	3.75	18.8	4.48	20.2	4.89	21.5	5.30	24.1	6.17	26.8	7.12
	33	13.6	3.26	16.2	3.97	18.8	4.76	20.2	5.19	21.5	5.64	24.1	6.56	26.8	7.59
	35	13.6	3.45	16.2	4.22	18.8	5.06	20.2	5.51	21.5	5.98	24.1	6.99	26.8	8.06
37	13.6	3.64	16.2	4.46	18.8	5.36	20.2	5.85	21.5	6.35	24.1	7.42	26.8	8.58	
39	13.6	3.84	16.2	4.70	18.8	5.67	20.2	6.22	21.5	6.70	24.1	7.88	26.8	9.10	

6. Capacity Tables

Combination (%)	Outdoor Air Temp. (°C DB)	Indoor Air Temp. (DB/WB, °C)													
		20		23		26		27		28		30		32	
		14		16		18		19		20		22		24	
		TC	PI	TC	PI	TC	PI	TC	PI	TC	PI	TC	PI	TC	PI
50	10	11.3	1.92	13.6	2.22	15.7	2.53	16.8	2.71	17.9	2.87	20.0	3.23	22.3	3.60
	12	11.3	1.94	13.6	2.24	15.7	2.57	16.8	2.75	17.9	2.93	20.0	3.29	22.3	3.66
	14	11.3	1.96	13.6	2.28	15.7	2.61	16.8	2.79	17.9	2.97	20.0	3.33	22.3	3.72
	16	11.3	2.00	13.6	2.32	15.7	2.65	16.8	2.85	17.9	3.01	20.0	3.39	22.3	3.78
	18	11.3	2.02	13.6	2.34	15.7	2.69	16.8	2.89	17.9	3.07	20.0	3.46	22.3	3.86
	20	11.3	2.04	13.6	2.38	15.7	2.75	16.8	2.93	17.9	3.13	20.0	3.52	22.3	3.94
	21	11.3	2.06	13.6	2.40	15.7	2.77	16.8	2.97	17.9	3.15	20.0	3.56	22.3	3.98
	23	11.3	2.10	13.6	2.44	15.7	2.81	16.8	3.01	17.9	3.21	20.0	3.62	22.3	4.06
	25	11.3	2.12	13.6	2.49	15.7	2.87	16.8	3.07	17.9	3.31	20.0	3.80	22.3	4.34
	27	11.3	2.16	13.6	2.57	15.7	3.03	16.8	3.27	17.9	3.52	20.0	4.06	22.3	4.63
	29	11.3	2.28	13.6	2.73	15.7	3.21	16.8	3.48	17.9	3.74	20.0	4.30	22.3	4.91
	31	11.3	2.40	13.6	2.89	15.7	3.41	16.8	3.68	17.9	3.98	20.0	4.59	22.3	5.23
	33	11.3	2.55	13.6	3.05	15.7	3.62	16.8	3.90	17.9	4.22	20.0	4.87	22.3	5.58
	35	11.3	2.69	13.6	3.23	15.7	3.82	16.8	4.14	17.9	4.47	20.0	5.15	22.3	5.92
	37	11.3	2.85	13.6	3.41	15.7	4.04	16.8	4.38	17.9	4.73	20.0	5.50	22.3	6.28
	39	11.3	2.98	13.6	3.59	15.7	4.29	16.8	4.63	17.9	4.97	20.0	5.80	22.3	6.65

Note

1. TC: Total Capacity(kW), PI : Power Input(kW, Comp. + Outdoor fan motor)
2. Capacity tables show the average value of conditions which may occur.

6. Capacity Tables

6.2 Heating Capacity

6.2.1 1 Phase / Heat Pump

◆ ARUN040GSS0

Combination (%)	Outdoor air temp		Indoor air temp. °C DB											
			16		18		20		21		22		24	
	°C DB	°C WB	TC	PI	TC	PI	TC	PI	TC	PI	TC	PI	TC	PI
130	-19.8	-20	10.0	4.87	10.0	4.90	9.9	4.93	9.9	4.97	9.9	5.01	9.7	5.07
	-18.8	-19	10.2	4.89	10.2	4.92	10.1	4.95	10.1	4.99	10.1	5.03	9.9	5.09
	-16.7	-17	10.7	4.93	10.7	4.96	10.6	4.99	10.6	5.03	10.6	5.07	10.4	5.14
	-13.7	-15	11.4	5.00	11.4	5.03	11.3	5.05	11.3	5.10	11.3	5.14	11.1	4.91
	-11.8	-13	11.8	5.04	11.8	5.07	11.7	5.10	11.7	5.14	11.7	4.98	11.5	4.76
	-9.8	-11	12.1	5.08	12.1	5.11	12.1	5.14	12.1	4.97	12.1	4.81	12.0	4.61
	-9.5	-10	12.2	5.08	12.2	5.12	12.1	5.11	12.1	4.94	12.1	4.79	12.0	4.58
	-8.5	-9.1	12.4	5.11	12.4	5.14	12.4	5.02	12.4	4.85	12.3	4.71	12.3	4.51
	-7	-7.6	12.8	5.14	12.8	5.00	12.7	4.89	12.7	4.72	12.7	4.58	12.6	4.39
	-5	-5.6	13.3	4.95	13.3	4.82	13.2	4.71	13.2	4.55	13.2	4.41	13.1	4.24
	-3	-3.7	13.7	4.77	13.7	4.64	13.6	4.53	13.6	4.38	13.6	4.25	13.5	4.08
	0	-0.7	14.4	4.50	14.4	4.37	14.3	4.26	14.3	4.12	14.3	4.00	14.1	3.85
	3	2.2	15.1	4.22	15.1	4.10	15.0	3.99	15.0	3.87	15.0	3.75	14.1	3.62
	5	4.1	15.6	4.04	15.6	3.92	15.5	3.81	15.5	3.69	15.2	3.58	14.1	3.47
	7	6	16.0	3.86	16.0	3.74	15.9	3.63	15.7	3.52	15.2	3.42	14.1	3.31
9	7.9	16.2	3.71	16.2	3.59	16.1	3.48	15.7	3.38	15.2	3.28	14.1	3.18	
11	9.8	16.2	3.58	16.2	3.47	16.1	3.37	15.7	3.27	15.2	3.17	14.1	3.08	
13	11.8	16.2	3.45	16.2	3.34	16.1	3.24	15.7	3.15	15.2	3.05	14.1	2.96	
15	13.7	16.2	3.31	16.2	3.20	16.1	3.11	15.7	3.02	15.2	2.93	14.1	2.84	
120	-19.8	-20	9.9	4.90	9.9	4.93	9.8	4.97	9.8	5.01	9.8	5.07	9.6	5.12
	-18.8	-19	10.1	4.92	10.1	4.95	10.1	4.99	10.1	5.03	10.1	5.09	9.8	5.14
	-16.7	-17	10.6	4.96	10.6	4.99	10.5	5.03	10.5	5.07	10.5	5.14	10.3	4.99
	-13.7	-15	11.3	5.03	11.3	5.05	11.2	5.10	11.2	5.14	11.2	4.91	11.0	4.78
	-11.8	-13	11.7	5.07	11.7	5.10	11.6	5.14	11.6	4.98	11.6	4.77	11.4	4.64
	-9.8	-11	12.1	5.11	12.1	5.14	12.0	4.96	12.0	4.81	12.0	4.62	11.9	4.50
	-9.5	-10	12.1	5.12	12.1	5.11	12.1	4.93	12.1	4.79	12.1	4.60	12.0	4.48
	-8.5	-9.1	12.4	5.14	12.4	5.01	12.3	4.85	12.3	4.70	12.3	4.53	12.2	4.41
	-7	-7.6	12.7	4.99	12.7	4.87	12.6	4.71	12.6	4.58	12.6	4.42	12.5	4.30
	-5	-5.6	13.2	4.80	13.2	4.68	13.1	4.54	13.1	4.41	13.1	4.27	13.0	4.16
	-3	-3.7	13.6	4.61	13.6	4.49	13.5	4.36	13.5	4.24	13.5	4.12	13.3	4.02
	0	-0.7	14.3	4.32	14.3	4.21	14.2	4.09	14.2	3.99	14.2	3.89	13.3	3.81
	3	2.2	15.0	4.03	15.0	3.92	14.9	3.83	14.7	3.74	14.3	3.67	13.3	3.60
	5	4.1	15.5	3.83	15.5	3.73	15.2	3.65	14.7	3.57	14.3	3.52	13.3	3.45
	7	6	15.9	3.64	15.9	3.54	15.2	3.47	14.7	3.41	14.3	3.37	13.3	3.31
9	7.9	16.0	3.49	15.9	3.39	15.2	3.33	14.7	3.26	14.3	3.23	13.3	3.18	
11	9.8	16.0	3.37	15.9	3.28	15.2	3.21	14.7	3.15	14.3	3.12	13.3	3.06	
13	11.8	16.0	3.24	15.9	3.15	15.2	3.09	14.7	3.03	14.3	3.00	13.3	2.95	
15	13.7	16.0	3.10	15.9	3.02	15.2	2.96	14.7	2.90	14.3	2.87	13.3	2.82	
110	-19.8	-20	9.8	4.93	9.8	4.97	9.8	5.01	9.8	5.07	9.8	5.12	9.6	5.14
	-18.8	-19	10.1	4.95	10.1	4.99	10.0	5.03	10.0	5.09	10.0	5.14	9.8	5.06
	-16.7	-17	10.5	4.99	10.5	5.03	10.5	5.07	10.5	5.14	10.5	4.98	10.3	4.90
	-13.7	-15	11.2	5.05	11.2	5.10	11.2	5.14	11.2	4.90	11.2	4.75	11.2	4.67
	-11.8	-13	11.6	5.10	11.6	5.14	11.5	4.97	11.5	4.74	11.5	4.61	11.5	4.53
	-9.8	-11	12.0	5.14	12.0	4.94	11.9	4.79	11.9	4.58	11.9	4.46	11.9	4.38
	-9.5	-10	12.1	5.11	12.1	4.91	12.0	4.76	12.0	4.56	12.0	4.44	11.9	4.35
	-8.5	-9.1	12.3	5.00	12.3	4.82	12.2	4.67	12.2	4.48	12.2	4.36	11.9	4.28
	-7	-7.6	12.6	4.84	12.6	4.67	12.6	4.54	12.6	4.36	12.6	4.25	11.9	4.16
	-5	-5.6	13.1	4.63	13.1	4.48	13.0	4.36	13.0	4.20	12.8	4.10	11.9	4.01
	-3	-3.7	13.5	4.42	13.5	4.28	13.5	4.18	13.2	4.04	12.8	3.95	11.9	3.86
	0	-0.7	14.2	4.10	14.2	3.99	13.7	3.91	13.2	3.80	12.8	3.72	11.9	3.63
	3	2.2	14.9	3.79	14.6	3.70	13.7	3.64	13.2	3.56	12.8	3.50	11.9	3.40
	5	4.1	15.4	3.58	14.6	3.51	13.7	3.46	13.2	3.40	12.8	3.35	11.9	3.25
	7	6	15.4	3.36	14.6	3.31	13.7	3.28	13.2	3.24	12.8	3.20	11.9	3.10
9	7.9	15.4	3.21	14.6	3.16	13.7	3.13	13.2	3.09	12.8	3.05	11.9	2.96	
11	9.8	15.4	3.09	14.6	3.04	13.7	3.00	13.2	2.97	12.8	2.93	11.9	2.84	
13	11.8	15.4	2.95	14.6	2.91	13.7	2.87	13.2	2.84	12.8	2.80	11.9	2.72	
15	13.7	15.4	2.81	14.6	2.77	13.7	2.74	13.2	2.70	12.8	2.67	11.9	2.59	

6. Capacity Tables

Combination (%)	Outdoor air temp		Indoor air temp. °C DB											
			16		18		20		21		22		24	
	°C DB	°C WB	TC	PI	TC	PI	TC	PI	TC	PI	TC	PI	TC	PI
100	-19.8	-20	9.8	5.27	9.8	5.24	9.7	5.18	9.7	5.18	9.7	5.18	9.5	5.14
	-18.8	-19	10.0	5.26	10.0	5.23	10.0	5.21	10.0	5.17	10.0	5.14	9.8	5.05
	-16.7	-17	10.4	5.23	10.4	5.20	10.4	5.25	10.4	5.14	10.4	4.95	10.2	4.86
	-13.7	-15	11.2	5.19	11.2	5.16	11.1	5.14	11.1	4.86	11.1	4.68	10.9	4.59
	-11.8	-13	11.5	5.16	11.5	5.14	11.5	4.95	11.5	4.69	11.5	4.51	10.9	4.42
	-9.8	-11	11.9	5.14	11.9	4.93	11.9	4.75	11.9	4.51	11.7	4.34	10.9	4.24
	-9.5	-10	12.0	5.10	12.0	4.89	11.9	4.72	11.9	4.48	11.7	4.31	10.9	4.21
	-8.5	-9.1	12.2	4.99	12.2	4.79	12.2	4.63	12.1	4.39	11.7	4.22	10.9	4.12
	-7	-7.6	12.8	4.82	12.7	4.63	12.5	4.48	12.1	4.25	11.7	4.09	10.9	3.99
	-5	-5.6	13.3	4.60	13.2	4.42	12.5	4.28	12.1	4.07	11.7	3.91	10.9	3.81
	-3	-3.7	13.7	4.38	13.3	4.21	12.5	4.08	12.1	3.88	11.7	3.73	10.9	3.63
	0	-0.7	14.1	4.04	13.3	3.89	12.5	3.79	12.1	3.61	11.7	3.46	10.9	3.36
	3	2.2	14.1	3.70	13.3	3.58	12.5	3.49	12.1	3.33	11.7	3.19	10.9	3.09
	5	4.1	14.1	3.48	13.3	3.37	12.5	3.30	12.1	3.15	11.7	3.02	10.9	2.91
	7	6	14.1	3.26	13.3	3.15	12.5	3.10	12.1	2.97	11.7	2.84	10.9	2.73
	9	7.9	14.1	3.09	13.3	2.99	12.5	2.94	12.1	2.81	11.7	2.69	10.9	2.59
11	9.8	14.1	2.94	13.3	2.85	12.5	2.80	12.1	2.68	11.7	2.56	10.9	2.47	
13	11.8	14.1	2.79	13.3	2.70	12.5	2.66	12.1	2.54	11.7	2.43	10.9	2.34	
15	13.7	14.1	2.63	13.3	2.55	12.5	2.50	12.1	2.40	11.7	2.29	10.9	2.20	
90	-19.8	-20	9.7	4.85	9.7	4.91	9.7	4.96	9.7	4.98	9.7	4.81	9.5	4.59
	-18.8	-19	10.0	4.87	10.0	4.93	9.9	4.98	9.9	4.89	9.9	4.73	9.7	4.51
	-16.7	-17	10.4	4.91	10.4	4.98	10.4	4.80	10.4	4.72	10.4	4.56	10.0	4.34
	-13.7	-15	11.2	4.98	11.2	4.71	11.1	4.55	11.1	4.46	10.7	4.32	10.0	4.11
	-11.8	-13	11.5	4.79	11.5	4.54	11.4	4.39	11.1	4.30	10.7	4.16	10.0	3.96
	-9.8	-11	11.9	4.60	11.9	4.37	11.4	4.22	11.1	4.13	10.7	4.00	10.0	3.80
	-9.5	-10	12.0	4.57	12.0	4.34	11.4	4.20	11.1	4.11	10.7	3.98	10.0	3.78
	-8.5	-9.1	12.2	4.47	12.1	4.25	11.4	4.11	11.1	4.02	10.7	3.89	10.0	3.70
	-7	-7.6	12.8	4.33	12.1	4.12	11.4	3.99	11.1	3.90	10.7	3.77	10.0	3.58
	-5	-5.6	12.9	4.14	12.1	3.94	11.4	3.82	11.1	3.73	10.7	3.61	10.0	3.42
	-3	-3.7	12.9	3.94	12.1	3.77	11.4	3.65	11.1	3.56	10.7	3.45	10.0	3.27
	0	-0.7	12.9	3.65	12.1	3.50	11.4	3.40	11.1	3.30	10.7	3.20	10.0	3.03
	3	2.2	12.9	3.36	12.1	3.24	11.4	3.14	11.1	3.05	10.7	2.96	10.0	2.80
	5	4.1	12.9	3.17	12.1	3.06	11.4	2.98	11.1	2.88	10.7	2.79	10.0	2.64
	7	6	12.9	2.98	12.1	2.88	11.4	2.81	11.1	2.71	10.7	2.63	10.0	2.48
	9	7.9	12.9	2.80	12.1	2.71	11.4	2.64	11.1	2.55	10.7	2.47	10.0	2.33
11	9.8	12.9	2.62	12.1	2.54	11.4	2.47	11.1	2.39	10.7	2.32	10.0	2.18	
13	11.8	12.9	2.44	12.1	2.37	11.4	2.30	11.1	2.22	10.7	2.16	10.0	2.04	
15	13.7	12.9	2.26	12.1	2.19	11.4	2.13	11.1	2.06	10.7	2.00	10.0	1.89	
80	-19.8	-20	9.6	4.28	9.6	4.35	9.6	4.41	9.6	4.27	9.6	4.07	8.9	3.88
	-18.8	-19	9.9	4.31	9.9	4.41	9.9	4.34	9.9	4.19	9.6	4.00	8.9	3.81
	-16.7	-17	10.2	4.41	10.2	4.25	10.2	4.18	9.9	4.04	9.6	3.85	8.9	3.67
	-13.7	-15	10.2	4.18	10.2	4.03	10.2	3.95	9.9	3.82	9.6	3.65	8.9	3.48
	-11.8	-13	10.2	4.03	10.2	3.88	10.2	3.81	9.9	3.68	9.6	3.51	8.9	3.35
	-9.8	-11	10.2	3.87	10.2	3.73	10.2	3.66	9.9	3.53	9.6	3.38	8.9	3.22
	-9.5	-10	10.3	3.84	10.3	3.71	10.2	3.64	9.9	3.51	9.6	3.36	8.9	3.20
	-8.5	-9.1	10.9	3.76	10.9	3.63	10.2	3.56	9.9	3.43	9.6	3.29	8.9	3.13
	-7	-7.6	11.6	3.64	10.9	3.52	10.2	3.45	9.9	3.32	9.6	3.18	8.9	3.04
	-5	-5.6	11.6	3.49	10.9	3.37	10.2	3.30	9.9	3.17	9.6	3.04	8.9	2.90
	-3	-3.7	11.6	3.33	10.9	3.22	10.2	3.14	9.9	3.03	9.6	2.91	8.9	2.77
	0	-0.7	11.6	3.09	10.9	2.99	10.2	2.92	9.9	2.81	9.6	2.70	8.9	2.57
	3	2.2	11.6	2.85	10.9	2.76	10.2	2.69	9.9	2.58	9.6	2.49	8.9	2.38
	5	4.1	11.6	2.69	10.9	2.61	10.2	2.54	9.9	2.44	9.6	2.35	8.9	2.25
	7	6	11.6	2.54	10.9	2.46	10.2	2.39	9.9	2.29	9.6	2.21	8.9	2.11
	9	7.9	11.6	2.38	10.9	2.31	10.2	2.24	9.9	2.15	9.6	2.08	8.9	1.99
11	9.8	11.6	2.21	10.9	2.15	10.2	2.08	9.9	2.00	9.6	1.93	8.9	1.84	
13	11.8	11.6	2.06	10.9	2.00	10.2	1.94	9.9	1.86	9.6	1.80	8.9	1.72	
15	13.7	11.6	1.94	10.9	1.89	10.2	1.83	9.9	1.75	9.6	1.70	8.9	1.62	

6. Capacity Tables

Combination (%)	Outdoor air temp		Indoor air temp. °C DB											
			16		18		20		21		22		24	
	°C DB	°C WB	TC	PI	TC	PI	TC	PI	TC	PI	TC	PI	TC	PI
70	-19.8	-20	9.6	4.29	9.3	4.31	8.7	4.15	8.4	3.94	8.2	3.74	7.6	3.55
	-18.8	-19	9.8	4.31	9.3	4.23	8.7	4.07	8.4	3.87	8.2	3.67	7.6	3.49
	-16.7	-17	9.8	4.14	9.3	4.06	8.7	3.91	8.4	3.71	8.2	3.53	7.6	3.35
	-13.7	-15	9.8	3.89	9.3	3.81	8.7	3.67	8.4	3.49	8.2	3.32	7.6	3.15
	-11.8	-13	9.8	3.74	9.3	3.66	8.7	3.52	8.4	3.35	8.2	3.19	7.6	3.02
	-9.8	-11	9.8	3.58	9.3	3.49	8.7	3.37	8.4	3.20	8.2	3.05	7.6	2.89
	-9.5	-10	9.8	3.55	9.3	3.47	8.7	3.34	8.4	3.18	8.2	3.03	7.6	2.87
	-8.5	-9.1	9.8	3.47	9.3	3.39	8.7	3.27	8.4	3.10	8.2	2.96	7.6	2.81
	-7	-7.6	9.8	3.35	9.3	3.26	8.7	3.15	8.4	2.99	8.2	2.86	7.6	2.71
	-5	-5.6	9.8	3.19	9.3	3.10	8.7	2.99	8.4	2.84	8.2	2.72	7.6	2.57
	-3	-3.7	9.8	3.02	9.3	2.94	8.7	2.83	8.4	2.70	8.2	2.59	7.6	2.44
	0	-0.7	9.8	2.78	9.3	2.69	8.7	2.60	8.4	2.47	8.2	2.38	7.6	2.24
	3	2.2	9.8	2.53	9.3	2.45	8.7	2.36	8.4	2.25	8.2	2.17	7.6	2.05
	5	4.1	9.8	2.37	9.3	2.28	8.7	2.21	8.4	2.10	8.2	2.03	7.6	1.91
	7	6	9.8	2.21	9.3	2.12	8.7	2.05	8.4	1.96	8.2	1.90	7.6	1.78
9	7.9	9.8	1.99	9.3	1.91	8.7	1.85	8.4	1.77	8.2	1.71	7.6	1.61	
11	9.8	9.8	1.86	9.3	1.78	8.7	1.72	8.4	1.64	8.2	1.59	7.6	1.50	
13	11.8	9.8	1.74	9.3	1.67	8.7	1.61	8.4	1.54	8.2	1.49	7.6	1.40	
15	13.7	9.8	1.64	9.3	1.57	8.7	1.52	8.4	1.45	8.2	1.41	7.6	1.32	
60	-19.8	-20	8.4	4.25	8.0	4.08	7.5	3.85	7.2	3.64	7.0	3.45	6.5	3.26
	-18.8	-19	8.4	4.16	8.0	4.00	7.5	3.78	7.2	3.57	7.0	3.38	6.5	3.19
	-16.7	-17	8.4	3.98	8.0	3.82	7.5	3.61	7.2	3.42	7.0	3.24	6.5	3.05
	-13.7	-15	8.4	3.73	8.0	3.57	7.5	3.38	7.2	3.20	7.0	3.03	6.5	2.86
	-11.8	-13	8.4	3.56	8.0	3.41	7.5	3.23	7.2	3.06	7.0	2.90	6.5	2.73
	-9.8	-11	8.4	3.39	8.0	3.24	7.5	3.07	7.2	2.91	7.0	2.76	6.5	2.60
	-9.5	-10	8.4	3.37	8.0	3.22	7.5	3.05	7.2	2.89	7.0	2.74	6.5	2.58
	-8.5	-9.1	8.4	3.28	8.0	3.13	7.5	2.97	7.2	2.82	7.0	2.67	6.5	2.52
	-7	-7.6	8.4	3.15	8.0	3.01	7.5	2.85	7.2	2.71	7.0	2.57	6.5	2.42
	-5	-5.6	8.4	2.98	8.0	2.84	7.5	2.69	7.2	2.56	7.0	2.43	6.5	2.29
	-3	-3.7	8.4	2.81	8.0	2.67	7.5	2.53	7.2	2.41	7.0	2.30	6.5	2.16
	0	-0.7	8.4	2.56	8.0	2.42	7.5	2.30	7.2	2.19	7.0	2.09	6.5	1.96
	3	2.2	8.4	2.30	8.0	2.17	7.5	2.06	7.2	1.97	7.0	1.89	6.5	1.76
	5	4.1	8.4	2.13	8.0	2.00	7.5	1.91	7.2	1.83	7.0	1.75	6.5	1.63
	7	6	8.4	1.96	8.0	1.83	7.5	1.75	7.2	1.68	7.0	1.61	6.5	1.50
9	7.9	8.4	1.75	8.0	1.64	7.5	1.56	7.2	1.50	7.0	1.44	6.5	1.34	
11	9.8	8.4	1.63	8.0	1.53	7.5	1.46	7.2	1.40	7.0	1.34	6.5	1.25	
13	11.8	8.4	1.53	8.0	1.43	7.5	1.36	7.2	1.31	7.0	1.26	6.5	1.17	
15	13.7	8.4	1.44	8.0	1.35	7.5	1.29	7.2	1.24	7.0	1.19	6.5	1.11	
50	-19.8	-20	7.0	3.52	6.6	3.32	6.2	3.14	6.0	2.97	5.8	2.81	5.4	2.65
	-18.8	-19	7.0	3.45	6.6	3.25	6.2	3.07	6.0	2.91	5.8	2.75	5.4	2.60
	-16.7	-17	7.0	3.29	6.6	3.11	6.2	2.94	6.0	2.78	5.8	2.63	5.4	2.49
	-13.7	-15	7.0	3.08	6.6	2.90	6.2	2.75	6.0	2.60	5.8	2.47	5.4	2.33
	-11.8	-13	7.0	2.94	6.6	2.77	6.2	2.63	6.0	2.48	5.8	2.36	5.4	2.23
	-9.8	-11	7.0	2.80	6.6	2.63	6.2	2.50	6.0	2.36	5.8	2.25	5.4	2.12
	-9.5	-10	7.0	2.77	6.6	2.61	6.2	2.48	6.0	2.35	5.8	2.23	5.4	2.10
	-8.5	-9.1	7.0	2.70	6.6	2.54	6.2	2.42	6.0	2.29	5.8	2.18	5.4	2.05
	-7	-7.6	7.0	2.59	6.6	2.44	6.2	2.32	6.0	2.20	5.8	2.09	5.4	1.97
	-5	-5.6	7.0	2.45	6.6	2.30	6.2	2.19	6.0	2.08	5.8	1.98	5.4	1.86
	-3	-3.7	7.0	2.30	6.6	2.17	6.2	2.06	6.0	1.95	5.8	1.87	5.4	1.76
	0	-0.7	7.0	2.09	6.6	1.96	6.2	1.87	6.0	1.77	5.8	1.70	5.4	1.60
	3	2.2	7.0	1.87	6.6	1.75	6.2	1.68	6.0	1.59	5.8	1.53	5.4	1.44
	5	4.1	7.0	1.72	6.6	1.62	6.2	1.55	6.0	1.47	5.8	1.42	5.4	1.33
	7	6	7.0	1.58	6.6	1.48	6.2	1.42	6.0	1.35	5.8	1.31	5.4	1.22
9	7.9	7.0	1.43	6.6	1.34	6.2	1.29	6.0	1.22	5.8	1.18	5.4	1.10	
11	9.8	7.0	1.33	6.6	1.25	6.2	1.20	6.0	1.14	5.8	1.11	5.4	1.03	
13	11.8	7.0	1.25	6.6	1.17	6.2	1.13	6.0	1.07	5.8	1.04	5.4	0.97	
15	13.7	7.0	1.19	6.6	1.11	6.2	1.07	6.0	1.02	5.8	0.98	5.4	0.92	

Note

1. TC: Total Capacity(kW), PI : Power Input(kW, Comp. + Outdoor fan motor)
2. Capacity tables show the average value of conditions which may occur.

6. Capacity Tables

◆ ARUN050GSL0

Combination (%)	Outdoor air temp		Indoor air temp. °C DB											
			16		18		20		21		22		24	
	°C DB	°C WB	TC	PI	TC	PI	TC	PI	TC	PI	TC	PI	TC	PI
130	-19.8	-20	11.9	6.25	11.9	6.29	11.9	6.32	11.9	6.38	11.9	6.43	11.6	6.51
	-18.8	-19	12.2	6.28	12.2	6.32	12.1	6.35	12.1	6.41	12.1	6.46	11.9	6.54
	-16.7	-17	12.8	6.33	12.8	6.37	12.7	6.41	12.7	6.46	12.7	6.51	12.5	6.60
	-13.7	-15	13.7	6.41	13.7	6.45	13.6	6.49	13.6	6.54	13.6	6.60	13.3	6.30
	-11.8	-13	14.1	6.47	14.1	6.51	14.0	6.54	14.0	6.60	14.0	6.39	13.8	6.11
	-9.8	-11	14.6	6.52	14.6	6.56	14.5	6.60	14.5	6.38	14.5	6.18	14.4	5.91
	-9.5	-10	14.7	6.53	14.7	6.57	14.6	6.56	14.6	6.34	14.6	6.15	14.5	5.88
	-8.5	-9.1	14.9	6.56	14.9	6.60	14.8	6.45	14.8	6.23	14.8	6.04	14.7	5.79
	-7	-7.6	15.3	6.60	15.3	6.42	15.3	6.27	15.3	6.07	15.3	5.88	15.1	5.64
	-5	-5.6	15.9	6.36	15.9	6.19	15.8	6.04	15.8	5.85	15.8	5.67	15.7	5.44
	-3	-3.7	16.5	6.13	16.5	5.96	16.4	5.81	16.4	5.62	16.4	5.45	16.2	5.24
	0	-0.7	17.3	5.78	17.3	5.61	17.2	5.46	17.2	5.29	17.2	5.13	16.9	4.95
	3	2.2	18.1	5.42	18.1	5.26	18.0	5.12	18.0	4.96	18.0	4.81	16.9	4.65
	5	4.1	18.7	5.19	18.7	5.03	18.6	4.89	18.6	4.74	18.2	4.60	16.9	4.45
	7	6	19.2	4.96	19.2	4.80	19.1	4.66	18.8	4.52	18.2	4.39	16.9	4.26
	9	7.9	19.4	4.76	19.4	4.60	19.3	4.47	18.8	4.34	18.2	4.21	16.9	4.08
11	9.8	19.4	4.60	19.4	4.45	19.3	4.32	18.8	4.19	18.2	4.07	16.9	3.95	
13	11.8	19.4	4.43	19.4	4.29	19.3	4.16	18.8	4.04	18.2	3.92	16.9	3.80	
15	13.7	19.4	4.25	19.4	4.11	19.3	3.99	18.8	3.88	18.2	3.76	16.9	3.65	
120	-19.8	-20	11.9	6.29	11.9	6.32	11.8	6.38	11.8	6.43	11.8	6.51	11.5	6.57
	-18.8	-19	12.1	6.32	12.1	6.35	12.1	6.41	12.1	6.46	12.1	6.54	11.8	6.60
	-16.7	-17	12.7	6.37	12.7	6.41	12.6	6.46	12.6	6.51	12.6	6.60	12.4	6.41
	-13.7	-15	13.6	6.45	13.6	6.49	13.5	6.54	13.5	6.60	13.5	6.31	13.2	6.13
	-11.8	-13	14.0	6.51	14.0	6.54	13.9	6.60	13.9	6.39	13.9	6.13	13.7	5.96
	-9.8	-11	14.5	6.56	14.5	6.60	14.4	6.37	14.4	6.18	14.4	5.94	14.3	5.78
	-9.5	-10	14.6	6.57	14.6	6.56	14.5	6.33	14.5	6.14	14.5	5.91	14.3	5.75
	-8.5	-9.1	14.8	6.60	14.8	6.44	14.7	6.22	14.7	6.04	14.7	5.81	14.6	5.66
	-7	-7.6	15.2	6.41	15.2	6.25	15.1	6.05	15.1	5.88	15.1	5.67	15.0	5.52
	-5	-5.6	15.8	6.16	15.8	6.01	15.7	5.82	15.7	5.66	15.7	5.48	15.6	5.34
	-3	-3.7	16.3	5.91	16.3	5.77	16.2	5.59	16.2	5.45	16.2	5.29	15.9	5.16
	0	-0.7	17.2	5.54	17.2	5.40	17.1	5.25	17.1	5.12	17.1	5.00	15.9	4.89
	3	2.2	18.0	5.17	18.0	5.03	17.9	4.91	17.7	4.80	17.1	4.71	15.9	4.62
	5	4.1	18.5	4.92	18.5	4.79	18.3	4.69	17.7	4.59	17.1	4.52	15.9	4.44
	7	6	19.1	4.67	19.0	4.55	18.3	4.46	17.7	4.37	17.1	4.33	15.9	4.25
	9	7.9	19.2	4.48	19.0	4.36	18.3	4.27	17.7	4.19	17.1	4.15	15.9	4.08
11	9.8	19.2	4.32	19.0	4.21	18.3	4.12	17.7	4.04	17.1	4.01	15.9	3.93	
13	11.8	19.2	4.16	19.0	4.04	18.3	3.96	17.7	3.89	17.1	3.85	15.9	3.78	
15	13.7	19.2	3.98	19.0	3.87	18.3	3.80	17.7	3.72	17.1	3.69	15.9	3.62	
110	-19.8	-20	11.8	6.32	11.8	6.38	11.7	6.43	11.7	6.51	11.7	6.57	11.5	6.60
	-18.8	-19	12.1	6.35	12.1	6.41	12.0	6.46	12.0	6.54	12.0	6.60	11.8	6.50
	-16.7	-17	12.7	6.41	12.7	6.46	12.6	6.51	12.6	6.60	12.6	6.39	12.3	6.29
	-13.7	-15	13.5	6.49	13.5	6.54	13.4	6.60	13.4	6.29	13.4	6.10	13.4	6.00
	-11.8	-13	13.9	6.54	13.9	6.60	13.8	6.38	13.8	6.09	13.8	5.92	13.8	5.81
	-9.8	-11	14.4	6.60	14.4	6.35	14.3	6.15	14.3	5.89	14.3	5.73	14.3	5.62
	-9.5	-10	14.5	6.56	14.5	6.31	14.4	6.11	14.4	5.85	14.4	5.70	14.3	5.59
	-8.5	-9.1	14.7	6.42	14.7	6.18	14.7	6.00	14.7	5.75	14.7	5.60	14.3	5.49
	-7	-7.6	15.2	6.22	15.2	6.00	15.1	5.82	15.1	5.60	15.1	5.46	14.3	5.34
	-5	-5.6	15.7	5.95	15.7	5.75	15.6	5.59	15.6	5.39	15.3	5.26	14.3	5.15
	-3	-3.7	16.3	5.67	16.3	5.50	16.1	5.36	15.9	5.19	15.3	5.07	14.3	4.95
	0	-0.7	17.1	5.27	17.1	5.13	16.4	5.01	15.9	4.88	15.3	4.78	14.3	4.66
	3	2.2	17.9	4.86	17.5	4.75	16.4	4.67	15.9	4.57	15.3	4.49	14.3	4.37
	5	4.1	18.4	4.59	17.5	4.50	16.4	4.44	15.9	4.36	15.3	4.30	14.3	4.17
	7	6	18.5	4.32	17.5	4.25	16.4	4.21	15.9	4.16	15.3	4.10	14.3	3.98
	9	7.9	18.5	4.12	17.5	4.06	16.4	4.02	15.9	3.97	15.3	3.92	14.3	3.80
11	9.8	18.5	3.96	17.5	3.90	16.4	3.86	15.9	3.81	15.3	3.76	14.3	3.65	
13	11.8	18.5	3.79	17.5	3.73	16.4	3.69	15.9	3.65	15.3	3.60	14.3	3.49	
15	13.7	18.5	3.61	17.5	3.55	16.4	3.51	15.9	3.47	15.3	3.43	14.3	3.32	

6. Capacity Tables

Combination (%)	Outdoor air temp		Indoor air temp. °C DB											
			16		18		20		21		22		24	
	°C DB	°C WB	TC	PI	TC	PI	TC	PI	TC	PI	TC	PI	TC	PI
100	-19.8	-20	11.7	6.77	11.7	6.73	11.7	6.66	11.7	6.65	11.7	6.64	11.4	6.60
	-18.8	-19	12.0	6.75	11.9	6.72	11.9	6.68	11.9	6.63	11.9	6.60	11.7	6.48
	-16.7	-17	12.5	6.71	12.5	6.68	12.5	6.74	12.5	6.60	12.5	6.36	12.2	6.24
	-13.7	-15	13.4	6.66	13.4	6.63	13.3	6.60	13.3	6.24	13.3	6.01	13.1	5.89
	-11.8	-13	13.9	6.63	13.8	6.60	13.8	6.36	13.8	6.02	13.8	5.79	13.1	5.67
	-9.8	-11	14.3	6.60	14.3	6.32	14.2	6.10	14.2	5.78	14.0	5.57	13.1	5.44
	-9.5	-10	14.4	6.55	14.4	6.28	14.3	6.07	14.3	5.75	14.0	5.53	13.1	5.41
	-8.5	-9.1	14.7	6.41	14.7	6.15	14.6	5.94	14.5	5.63	14.0	5.42	13.1	5.29
	-7	-7.6	15.3	6.19	15.3	5.95	15.0	5.75	14.5	5.45	14.0	5.25	13.1	5.12
	-5	-5.6	16.0	5.91	15.8	5.68	15.0	5.50	14.5	5.22	14.0	5.02	13.1	4.89
	-3	-3.7	16.5	5.62	16.0	5.40	15.0	5.24	14.5	4.98	14.0	4.79	13.1	4.66
	0	-0.7	16.9	5.19	16.0	5.00	15.0	4.86	14.5	4.63	14.0	4.44	13.1	4.31
	3	2.2	16.9	4.76	16.0	4.59	15.0	4.49	14.5	4.28	14.0	4.10	13.1	3.97
	5	4.1	16.9	4.47	16.0	4.32	15.0	4.23	14.5	4.04	14.0	3.87	13.1	3.73
	7	6	16.9	4.18	16.0	4.05	15.0	3.98	14.5	3.81	14.0	3.64	13.1	3.50
	9	7.9	16.9	3.96	16.0	3.84	15.0	3.77	14.5	3.61	14.0	3.45	13.1	3.32
11	9.8	16.9	3.78	16.0	3.66	15.0	3.60	14.5	3.44	14.0	3.29	13.1	3.17	
13	11.8	16.9	3.58	16.0	3.47	15.0	3.41	14.5	3.26	14.0	3.12	13.1	3.00	
15	13.7	16.9	3.38	16.0	3.27	15.0	3.22	14.5	3.08	14.0	2.94	13.1	2.83	
90	-19.8	-20	11.7	6.23	11.7	6.31	11.6	6.36	11.6	6.39	11.6	6.18	11.4	5.89
	-18.8	-19	12.0	6.25	11.9	6.33	11.9	6.39	11.9	6.28	11.9	6.08	11.7	5.79
	-16.7	-17	12.5	6.31	12.5	6.39	12.5	6.16	12.5	6.05	12.5	5.86	12.0	5.57
	-13.7	-15	13.4	6.39	13.4	6.05	13.3	5.84	13.3	5.73	12.9	5.54	12.0	5.27
	-11.8	-13	13.9	6.15	13.8	5.84	13.7	5.63	13.3	5.52	12.9	5.34	12.0	5.08
	-9.8	-11	14.3	5.91	14.3	5.61	13.7	5.42	13.3	5.31	12.9	5.14	12.0	4.88
	-9.5	-10	14.4	5.87	14.4	5.57	13.7	5.39	13.3	5.27	12.9	5.10	12.0	4.85
	-8.5	-9.1	14.7	5.75	14.6	5.46	13.7	5.28	13.3	5.16	12.9	5.00	12.0	4.75
	-7	-7.6	15.3	5.56	14.6	5.29	13.7	5.12	13.3	5.00	12.9	4.84	12.0	4.60
	-5	-5.6	15.5	5.31	14.6	5.06	13.7	4.90	13.3	4.78	12.9	4.63	12.0	4.39
	-3	-3.7	15.5	5.06	14.6	4.84	13.7	4.68	13.3	4.57	12.9	4.42	12.0	4.19
	0	-0.7	15.5	4.69	14.6	4.50	13.7	4.36	13.3	4.24	12.9	4.11	12.0	3.89
	3	2.2	15.5	4.32	14.6	4.16	13.7	4.04	13.3	3.92	12.9	3.80	12.0	3.59
	5	4.1	15.5	4.07	14.6	3.93	13.7	3.82	13.3	3.70	12.9	3.59	12.0	3.39
	7	6	15.5	3.82	14.6	3.70	13.7	3.60	13.3	3.48	12.9	3.38	12.0	3.19
	9	7.9	15.5	3.59	14.6	3.48	13.7	3.39	13.3	3.27	12.9	3.18	12.0	2.99
11	9.8	15.5	3.36	14.6	3.26	13.7	3.17	13.3	3.06	12.9	2.97	12.0	2.80	
13	11.8	15.5	3.13	14.6	3.04	13.7	2.96	13.3	2.86	12.9	2.77	12.0	2.61	
15	13.7	15.5	2.91	14.6	2.82	13.7	2.74	13.3	2.65	12.9	2.57	12.0	2.42	
80	-19.8	-20	11.6	5.50	11.6	5.58	11.6	5.67	11.6	5.48	11.5	5.22	10.7	4.98
	-18.8	-19	11.8	5.53	11.8	5.67	11.8	5.57	11.8	5.38	11.5	5.13	10.7	4.89
	-16.7	-17	12.3	5.67	12.3	5.46	12.3	5.37	11.9	5.18	11.5	4.95	10.7	4.72
	-13.7	-15	12.3	5.36	12.3	5.17	12.3	5.08	11.9	4.90	11.5	4.68	10.7	4.46
	-11.8	-13	12.6	5.17	12.3	4.99	12.3	4.89	11.9	4.72	11.5	4.51	10.7	4.30
	-9.8	-11	13.1	4.96	12.8	4.79	12.3	4.70	11.9	4.53	11.5	4.33	10.7	4.13
	-9.5	-10	13.2	4.93	12.8	4.76	12.3	4.67	11.9	4.50	11.5	4.31	10.7	4.11
	-8.5	-9.1	13.5	4.83	13.1	4.67	12.3	4.57	11.9	4.41	11.5	4.22	10.7	4.02
	-7	-7.6	13.9	4.68	13.1	4.52	12.3	4.43	11.9	4.27	11.5	4.09	10.7	3.90
	-5	-5.6	13.9	4.48	13.1	4.33	12.3	4.23	11.9	4.08	11.5	3.91	10.7	3.73
	-3	-3.7	13.9	4.27	13.1	4.13	12.3	4.04	11.9	3.89	11.5	3.73	10.7	3.56
	0	-0.7	13.9	3.97	13.1	3.84	12.3	3.75	11.9	3.60	11.5	3.46	10.7	3.31
	3	2.2	13.9	3.66	13.1	3.55	12.3	3.46	11.9	3.32	11.5	3.20	10.7	3.05
	5	4.1	13.9	3.46	13.1	3.35	12.3	3.26	11.9	3.13	11.5	3.02	10.7	2.88
	7	6	13.9	3.25	13.1	3.16	12.3	3.07	11.9	2.94	11.5	2.84	10.7	2.71
	9	7.9	13.9	3.06	13.1	2.97	12.3	2.88	11.9	2.76	11.5	2.67	10.7	2.55
11	9.8	13.9	2.84	13.1	2.75	12.3	2.67	11.9	2.56	11.5	2.48	10.7	2.37	
13	11.8	13.9	2.65	13.1	2.57	12.3	2.50	11.9	2.39	11.5	2.31	10.7	2.21	
15	13.7	13.9	2.49	13.1	2.42	12.3	2.35	11.9	2.25	11.5	2.18	10.7	2.08	

6. Capacity Tables

Combination (%)	Outdoor air temp		Indoor air temp. °C DB											
			16		18		20		21		22		24	
	°C DB	°C WB	TC	PI	TC	PI	TC	PI	TC	PI	TC	PI	TC	PI
70	-19.8	-20	11.5	5.51	11.1	5.53	10.5	5.33	10.1	5.06	9.8	4.81	9.1	4.56
	-18.8	-19	11.8	5.53	11.1	5.43	10.5	5.23	10.1	4.96	9.8	4.72	9.1	4.47
	-16.7	-17	11.8	5.31	11.1	5.21	10.5	5.02	10.1	4.76	9.8	4.53	9.1	4.30
	-13.7	-15	11.8	5.00	11.1	4.89	10.5	4.72	10.1	4.48	9.8	4.27	9.1	4.04
	-11.8	-13	11.8	4.80	11.1	4.69	10.5	4.53	10.1	4.30	9.8	4.10	9.1	3.88
	-9.8	-11	11.8	4.59	11.1	4.48	10.5	4.32	10.1	4.11	9.8	3.92	9.1	3.71
	-9.5	-10	11.8	4.56	11.1	4.45	10.5	4.29	10.1	4.08	9.8	3.89	9.1	3.69
	-8.5	-9.1	11.8	4.46	11.1	4.35	10.5	4.19	10.1	3.98	9.8	3.81	9.1	3.60
	-7	-7.6	11.8	4.30	11.1	4.19	10.5	4.04	10.1	3.84	9.8	3.67	9.1	3.48
	-5	-5.6	11.8	4.09	11.1	3.98	10.5	3.84	10.1	3.65	9.8	3.50	9.1	3.31
	-3	-3.7	11.8	3.88	11.1	3.77	10.5	3.64	10.1	3.46	9.8	3.32	9.1	3.14
	0	-0.7	11.8	3.57	11.1	3.46	10.5	3.34	10.1	3.18	9.8	3.05	9.1	2.88
	3	2.2	11.8	3.25	11.1	3.14	10.5	3.03	10.1	2.89	9.8	2.79	9.1	2.63
	5	4.1	11.8	3.04	11.1	2.93	10.5	2.83	10.1	2.70	9.8	2.61	9.1	2.46
	7	6	11.8	2.83	11.1	2.72	10.5	2.63	10.1	2.51	9.8	2.43	9.1	2.29
9	7.9	11.8	2.56	11.1	2.46	10.5	2.37	10.1	2.27	9.8	2.20	9.1	2.07	
11	9.8	11.8	2.38	11.1	2.29	10.5	2.21	10.1	2.11	9.8	2.05	9.1	1.92	
13	11.8	11.8	2.23	11.1	2.14	10.5	2.07	10.1	1.97	9.8	1.92	9.1	1.80	
15	13.7	11.8	2.10	11.1	2.02	10.5	1.95	10.1	1.86	9.8	1.81	9.1	1.70	
60	-19.8	-20	10.1	5.45	9.6	5.24	9.0	4.95	8.7	4.68	8.4	4.43	7.8	4.18
	-18.8	-19	10.1	5.34	9.6	5.13	9.0	4.85	8.7	4.59	8.4	4.34	7.8	4.10
	-16.7	-17	10.1	5.11	9.6	4.90	9.0	4.64	8.7	4.39	8.4	4.16	7.8	3.92
	-13.7	-15	10.1	4.78	9.6	4.58	9.0	4.33	8.7	4.11	8.4	3.89	7.8	3.67
	-11.8	-13	10.1	4.58	9.6	4.38	9.0	4.14	8.7	3.93	8.4	3.72	7.8	3.51
	-9.8	-11	10.1	4.36	9.6	4.16	9.0	3.94	8.7	3.74	8.4	3.55	7.8	3.34
	-9.5	-10	10.1	4.32	9.6	4.13	9.0	3.91	8.7	3.71	8.4	3.52	7.8	3.31
	-8.5	-9.1	10.1	4.21	9.6	4.02	9.0	3.81	8.7	3.62	8.4	3.43	7.8	3.23
	-7	-7.6	10.1	4.05	9.6	3.86	9.0	3.66	8.7	3.48	8.4	3.30	7.8	3.10
	-5	-5.6	10.1	3.83	9.6	3.65	9.0	3.46	8.7	3.29	8.4	3.13	7.8	2.94
	-3	-3.7	10.1	3.61	9.6	3.43	9.0	3.25	8.7	3.10	8.4	2.95	7.8	2.77
	0	-0.7	10.1	3.28	9.6	3.11	9.0	2.95	8.7	2.82	8.4	2.69	7.8	2.51
	3	2.2	10.1	2.95	9.6	2.79	9.0	2.65	8.7	2.53	8.4	2.42	7.8	2.26
	5	4.1	10.1	2.73	9.6	2.57	9.0	2.45	8.7	2.35	8.4	2.25	7.8	2.09
	7	6	10.1	2.51	9.6	2.36	9.0	2.25	8.7	2.16	8.4	2.07	7.8	1.92
9	7.9	10.1	2.24	9.6	2.10	9.0	2.00	8.7	1.93	8.4	1.85	7.8	1.72	
11	9.8	10.1	2.09	9.6	1.96	9.0	1.87	8.7	1.80	8.4	1.72	7.8	1.60	
13	11.8	10.1	1.96	9.6	1.84	9.0	1.75	8.7	1.68	8.4	1.62	7.8	1.50	
15	13.7	10.1	1.85	9.6	1.74	9.0	1.66	8.7	1.59	8.4	1.53	7.8	1.42	
50	-19.8	-20	8.4	4.52	7.9	4.26	7.5	4.03	7.2	3.81	7.0	3.60	6.5	3.40
	-18.8	-19	8.4	4.43	7.9	4.17	7.5	3.95	7.2	3.73	7.0	3.53	6.5	3.34
	-16.7	-17	8.4	4.23	7.9	3.99	7.5	3.77	7.2	3.57	7.0	3.38	6.5	3.19
	-13.7	-15	8.4	3.95	7.9	3.73	7.5	3.53	7.2	3.34	7.0	3.17	6.5	2.99
	-11.8	-13	8.4	3.78	7.9	3.56	7.5	3.37	7.2	3.19	7.0	3.03	6.5	2.86
	-9.8	-11	8.4	3.59	7.9	3.38	7.5	3.21	7.2	3.03	7.0	2.89	6.5	2.72
	-9.5	-10	8.4	3.56	7.9	3.35	7.5	3.18	7.2	3.01	7.0	2.87	6.5	2.70
	-8.5	-9.1	8.4	3.47	7.9	3.27	7.5	3.10	7.2	2.93	7.0	2.79	6.5	2.63
	-7	-7.6	8.4	3.33	7.9	3.13	7.5	2.98	7.2	2.82	7.0	2.69	6.5	2.53
	-5	-5.6	8.4	3.14	7.9	2.96	7.5	2.81	7.2	2.66	7.0	2.54	6.5	2.39
	-3	-3.7	8.4	2.96	7.9	2.78	7.5	2.65	7.2	2.51	7.0	2.40	6.5	2.26
	0	-0.7	8.4	2.68	7.9	2.52	7.5	2.40	7.2	2.28	7.0	2.19	6.5	2.05
	3	2.2	8.4	2.40	7.9	2.25	7.5	2.16	7.2	2.05	7.0	1.97	6.5	1.84
	5	4.1	8.4	2.21	7.9	2.08	7.5	1.99	7.2	1.89	7.0	1.83	6.5	1.71
	7	6	8.4	2.03	7.9	1.90	7.5	1.83	7.2	1.74	7.0	1.68	6.5	1.57
9	7.9	8.4	1.83	7.9	1.71	7.5	1.65	7.2	1.57	7.0	1.52	6.5	1.42	
11	9.8	8.4	1.71	7.9	1.60	7.5	1.55	7.2	1.47	7.0	1.42	6.5	1.33	
13	11.8	8.4	1.61	7.9	1.51	7.5	1.45	7.2	1.38	7.0	1.34	6.5	1.25	
15	13.7	8.4	1.52	7.9	1.43	7.5	1.37	7.2	1.30	7.0	1.26	6.5	1.18	

Note

1. TC: Total Capacity(kW), PI : Power Input(kW, Comp. + Outdoor fan motor)
2. Capacity tables show the average value of conditions which may occur.

6. Capacity Tables

◆ ARUN050GSS0

Combination (%)	Outdoor air temp		Indoor air temp. °C DB											
			16		18		20		21		22		24	
	°C DB	°C WB	TC	PI	TC	PI	TC	PI	TC	PI	TC	PI	TC	PI
130	-19.8	-20	12.7	6.56	12.7	6.60	12.7	6.64	12.7	6.70	12.7	6.75	12.4	6.84
	-18.8	-19	13.0	6.59	13.0	6.63	13.0	6.67	13.0	6.73	13.0	6.78	12.7	6.87
	-16.7	-17	13.7	6.65	13.7	6.69	13.6	6.73	13.6	6.79	13.6	6.84	13.3	6.93
	-13.7	-15	14.6	6.74	14.6	6.78	14.5	6.82	14.5	6.87	14.5	6.93	14.2	6.62
	-11.8	-13	15.0	6.79	15.0	6.83	15.0	6.87	15.0	6.93	15.0	6.71	14.7	6.42
	-9.8	-11	15.5	6.85	15.5	6.89	15.4	6.93	15.4	6.70	15.4	6.49	15.3	6.21
	-9.5	-10	15.6	6.86	15.6	6.90	15.5	6.89	15.5	6.66	15.5	6.46	15.4	6.18
	-8.5	-9.1	15.9	6.88	15.9	6.93	15.8	6.77	15.8	6.54	15.8	6.34	15.7	6.08
	-7	-7.6	16.4	6.93	16.4	6.74	16.3	6.59	16.3	6.37	16.3	6.18	16.1	5.92
	-5	-5.6	17.0	6.68	17.0	6.50	16.9	6.35	16.9	6.14	16.9	5.95	16.7	5.71
	-3	-3.7	17.6	6.44	17.6	6.26	17.4	6.10	17.4	5.91	17.4	5.73	17.3	5.51
	0	-0.7	18.4	6.07	18.4	5.89	18.3	5.74	18.3	5.56	18.3	5.39	18.1	5.19
	3	2.2	19.3	5.70	19.3	5.52	19.2	5.38	19.2	5.21	19.2	5.06	18.1	4.88
	5	4.1	19.9	5.45	19.9	5.28	19.8	5.13	19.8	4.98	19.4	4.83	18.1	4.68
	7	6	20.5	5.20	20.5	5.04	20.4	4.89	20.1	4.75	19.4	4.61	18.1	4.47
	9	7.9	20.7	5.00	20.7	4.84	20.6	4.69	20.1	4.56	19.4	4.42	18.1	4.29
11	9.8	20.7	4.83	20.7	4.67	20.6	4.54	20.1	4.41	19.4	4.27	18.1	4.15	
13	11.8	20.7	4.65	20.7	4.50	20.6	4.37	20.1	4.24	19.4	4.12	18.1	3.99	
15	13.7	20.7	4.46	20.7	4.32	20.6	4.20	20.1	4.07	19.4	3.95	18.1	3.83	
120	-19.8	-20	12.6	6.60	12.6	6.64	12.6	6.70	12.6	6.75	12.6	6.84	12.3	6.90
	-18.8	-19	12.9	6.63	12.9	6.67	12.9	6.73	12.9	6.78	12.9	6.87	12.6	6.93
	-16.7	-17	13.6	6.69	13.6	6.73	13.5	6.79	13.5	6.84	13.5	6.93	13.2	6.73
	-13.7	-15	14.5	6.78	14.5	6.82	14.4	6.87	14.4	6.93	14.4	6.63	14.1	6.44
	-11.8	-13	14.9	6.83	14.9	6.87	14.8	6.93	14.8	6.71	14.8	6.44	14.6	6.26
	-9.8	-11	15.4	6.89	15.4	6.93	15.3	6.69	15.3	6.49	15.3	6.23	15.2	6.07
	-9.5	-10	15.5	6.90	15.5	6.89	15.4	6.65	15.4	6.45	15.4	6.20	15.3	6.04
	-8.5	-9.1	15.8	6.93	15.8	6.76	15.7	6.53	15.7	6.34	15.7	6.10	15.6	5.95
	-7	-7.6	16.3	6.73	16.3	6.57	16.2	6.35	16.2	6.17	16.2	5.95	16.0	5.80
	-5	-5.6	16.8	6.47	16.8	6.31	16.7	6.11	16.7	5.95	16.7	5.75	16.6	5.61
	-3	-3.7	17.4	6.21	17.4	6.06	17.3	5.88	17.3	5.72	17.3	5.55	17.0	5.42
	0	-0.7	18.3	5.82	18.3	5.67	18.2	5.52	18.2	5.38	18.2	5.25	17.0	5.13
	3	2.2	19.2	5.43	19.2	5.29	19.1	5.16	18.8	5.04	18.3	4.95	17.0	4.85
	5	4.1	19.8	5.17	19.8	5.03	19.5	4.92	18.8	4.82	18.3	4.75	17.0	4.66
	7	6	20.4	4.91	20.3	4.78	19.5	4.68	18.8	4.59	18.3	4.55	17.0	4.47
	9	7.9	20.5	4.70	20.3	4.58	19.5	4.49	18.8	4.40	18.3	4.36	17.0	4.28
11	9.8	20.5	4.54	20.3	4.42	19.5	4.33	18.8	4.25	18.3	4.21	17.0	4.13	
13	11.8	20.5	4.37	20.3	4.25	19.5	4.16	18.8	4.08	18.3	4.04	17.0	3.97	
15	13.7	20.5	4.18	20.3	4.07	19.5	3.99	18.8	3.91	18.3	3.87	17.0	3.80	
110	-19.8	-20	12.6	6.64	12.6	6.70	12.5	6.75	12.5	6.84	12.5	6.90	12.2	6.93
	-18.8	-19	12.9	6.67	12.9	6.73	12.8	6.78	12.8	6.87	12.8	6.93	12.5	6.82
	-16.7	-17	13.5	6.73	13.5	6.79	13.4	6.84	13.4	6.93	13.4	6.71	13.1	6.61
	-13.7	-15	14.4	6.82	14.4	6.87	14.3	6.93	14.3	6.60	14.3	6.41	14.3	6.30
	-11.8	-13	14.9	6.87	14.9	6.93	14.8	6.70	14.8	6.40	14.8	6.22	14.8	6.11
	-9.8	-11	15.3	6.93	15.3	6.67	15.3	6.45	15.3	6.18	15.3	6.01	15.2	5.90
	-9.5	-10	15.4	6.88	15.4	6.63	15.3	6.42	15.3	6.15	15.3	5.98	15.3	5.87
	-8.5	-9.1	15.7	6.74	15.7	6.50	15.6	6.30	15.6	6.04	15.6	5.88	15.3	5.77
	-7	-7.6	16.2	6.53	16.2	6.30	16.1	6.12	16.1	5.88	16.1	5.73	15.3	5.61
	-5	-5.6	16.8	6.24	16.8	6.04	16.6	5.87	16.6	5.66	16.4	5.53	15.3	5.41
	-3	-3.7	17.3	5.96	17.3	5.78	17.2	5.63	16.9	5.45	16.4	5.32	15.3	5.20
	0	-0.7	18.2	5.53	18.2	5.38	17.5	5.27	16.9	5.12	16.4	5.02	15.3	4.89
	3	2.2	19.1	5.11	18.6	4.99	17.5	4.90	16.9	4.80	16.4	4.71	15.3	4.59
	5	4.1	19.7	4.82	18.6	4.73	17.5	4.66	16.9	4.58	16.4	4.51	15.3	4.38
	7	6	19.7	4.54	18.6	4.47	17.5	4.42	16.9	4.36	16.4	4.31	15.3	4.18
	9	7.9	19.7	4.33	18.6	4.27	17.5	4.22	16.9	4.17	16.4	4.11	15.3	3.99
11	9.8	19.7	4.16	18.6	4.10	17.5	4.05	16.9	4.00	16.4	3.95	15.3	3.83	
13	11.8	19.7	3.98	18.6	3.92	17.5	3.88	16.9	3.83	16.4	3.78	15.3	3.66	
15	13.7	19.7	3.79	18.6	3.73	17.5	3.69	16.9	3.65	16.4	3.60	15.3	3.49	

6. Capacity Tables

Combination (%)	Outdoor air temp		Indoor air temp. °C DB											
			16		18		20		21		22		24	
	°C DB	°C WB	TC	PI	TC	PI	TC	PI	TC	PI	TC	PI	TC	PI
100	-19.8	-20	12.5	7.11	12.5	7.07	12.4	6.99	12.4	6.98	12.4	6.98	12.2	6.93
	-18.8	-19	12.8	7.09	12.7	7.05	12.7	7.02	12.7	6.97	12.7	6.93	12.5	6.81
	-16.7	-17	13.4	7.05	13.4	7.02	13.4	7.08	13.3	6.93	13.3	6.67	13.0	6.55
	-13.7	-15	14.3	7.00	14.3	6.96	14.2	6.93	14.2	6.56	14.2	6.31	14.0	6.19
	-11.8	-13	14.8	6.96	14.7	6.93	14.7	6.68	14.7	6.32	14.7	6.09	14.0	5.96
	-9.8	-11	15.3	6.93	15.3	6.64	15.2	6.41	15.2	6.07	15.0	5.85	14.0	5.72
	-9.5	-10	15.4	6.88	15.4	6.60	15.3	6.37	15.3	6.04	15.0	5.81	14.0	5.68
	-8.5	-9.1	15.6	6.73	15.6	6.46	15.6	6.24	15.5	5.91	15.0	5.69	14.0	5.56
	-7	-7.6	16.4	6.50	16.3	6.24	16.0	6.04	15.5	5.73	15.0	5.51	14.0	5.38
	-5	-5.6	17.1	6.20	16.9	5.96	16.0	5.77	15.5	5.48	15.0	5.27	14.0	5.13
	-3	-3.7	17.6	5.90	17.0	5.68	16.0	5.51	15.5	5.23	15.0	5.03	14.0	4.89
	0	-0.7	18.0	5.45	17.0	5.25	16.0	5.11	15.5	4.86	15.0	4.67	14.0	4.53
	3	2.2	18.0	5.00	17.0	4.82	16.0	4.71	15.5	4.49	15.0	4.31	14.0	4.16
	5	4.1	18.0	4.69	17.0	4.54	16.0	4.45	15.5	4.25	15.0	4.07	14.0	3.92
	7	6	18.0	4.39	17.0	4.25	16.0	4.18	15.5	4.00	15.0	3.83	14.0	3.68
	9	7.9	18.0	4.16	17.0	4.03	16.0	3.96	15.5	3.79	15.0	3.63	14.0	3.49
11	9.8	18.0	3.97	17.0	3.84	16.0	3.78	15.5	3.61	15.0	3.46	14.0	3.33	
13	11.8	18.0	3.76	17.0	3.65	16.0	3.58	15.5	3.43	15.0	3.28	14.0	3.15	
15	13.7	18.0	3.55	17.0	3.44	16.0	3.38	15.5	3.23	15.0	3.09	14.0	2.97	
90	-19.8	-20	12.5	6.54	12.5	6.62	12.4	6.68	12.4	6.71	12.4	6.49	12.1	6.18
	-18.8	-19	12.8	6.57	12.7	6.65	12.7	6.71	12.7	6.60	12.7	6.38	12.4	6.08
	-16.7	-17	13.4	6.63	13.4	6.71	13.3	6.47	13.3	6.36	13.3	6.15	12.8	5.85
	-13.7	-15	14.3	6.71	14.3	6.35	14.2	6.13	14.2	6.02	13.7	5.82	12.8	5.54
	-11.8	-13	14.8	6.46	14.7	6.13	14.6	5.92	14.2	5.80	13.7	5.61	12.8	5.34
	-9.8	-11	15.3	6.20	15.3	5.89	14.6	5.69	14.2	5.57	13.7	5.39	12.8	5.12
	-9.5	-10	15.4	6.16	15.4	5.85	14.6	5.66	14.2	5.54	13.7	5.36	12.8	5.09
	-8.5	-9.1	15.6	6.03	15.5	5.74	14.6	5.54	14.2	5.42	13.7	5.25	12.8	4.99
	-7	-7.6	16.4	5.84	15.6	5.56	14.6	5.37	14.2	5.25	13.7	5.09	12.8	4.83
	-5	-5.6	16.5	5.58	15.6	5.32	14.6	5.15	14.2	5.02	13.7	4.87	12.8	4.62
	-3	-3.7	16.5	5.32	15.6	5.08	14.6	4.92	14.2	4.80	13.7	4.65	12.8	4.40
	0	-0.7	16.5	4.93	15.6	4.72	14.6	4.58	14.2	4.45	13.7	4.32	12.8	4.09
	3	2.2	16.5	4.54	15.6	4.37	14.6	4.24	14.2	4.11	13.7	3.99	12.8	3.77
	5	4.1	16.5	4.27	15.6	4.13	14.6	4.01	14.2	3.88	13.7	3.77	12.8	3.56
	7	6	16.5	4.01	15.6	3.89	14.6	3.79	14.2	3.66	13.7	3.55	12.8	3.35
	9	7.9	16.5	3.77	15.6	3.66	14.6	3.56	14.2	3.44	13.7	3.34	12.8	3.15
11	9.8	16.5	3.53	15.6	3.42	14.6	3.33	14.2	3.22	13.7	3.12	12.8	2.94	
13	11.8	16.5	3.29	15.6	3.19	14.6	3.11	14.2	3.00	13.7	2.91	12.8	2.74	
15	13.7	16.5	3.05	15.6	2.96	14.6	2.88	14.2	2.78	13.7	2.70	12.8	2.54	
80	-19.8	-20	12.3	5.78	12.3	5.86	12.3	5.95	12.3	5.75	12.2	5.49	11.4	5.23
	-18.8	-19	12.6	5.81	12.6	5.95	12.6	5.85	12.6	5.65	12.2	5.39	11.4	5.14
	-16.7	-17	13.1	5.95	13.1	5.74	13.1	5.64	12.7	5.44	12.2	5.20	11.4	4.95
	-13.7	-15	13.1	5.63	13.1	5.43	13.1	5.33	12.7	5.15	12.2	4.92	11.4	4.69
	-11.8	-13	13.4	5.43	13.1	5.24	13.1	5.14	12.7	4.96	12.2	4.74	11.4	4.52
	-9.8	-11	14.0	5.21	13.6	5.03	13.1	4.93	12.7	4.76	12.2	4.55	11.4	4.34
	-9.5	-10	14.1	5.18	13.7	5.00	13.1	4.90	12.7	4.73	12.2	4.52	11.4	4.31
	-8.5	-9.1	14.4	5.08	13.9	4.90	13.1	4.80	12.7	4.63	12.2	4.43	11.4	4.23
	-7	-7.6	14.8	4.91	13.9	4.75	13.1	4.65	12.7	4.48	12.2	4.29	11.4	4.09
	-5	-5.6	14.8	4.70	13.9	4.54	13.1	4.44	12.7	4.28	12.2	4.10	11.4	3.92
	-3	-3.7	14.8	4.49	13.9	4.34	13.1	4.24	12.7	4.08	12.2	3.92	11.4	3.74
	0	-0.7	14.8	4.17	13.9	4.03	13.1	3.93	12.7	3.78	12.2	3.64	11.4	3.47
	3	2.2	14.8	3.85	13.9	3.73	13.1	3.63	12.7	3.49	12.2	3.36	11.4	3.21
	5	4.1	14.8	3.63	13.9	3.52	13.1	3.43	12.7	3.29	12.2	3.17	11.4	3.03
	7	6	14.8	3.42	13.9	3.32	13.1	3.22	12.7	3.09	12.2	2.99	11.4	2.85
	9	7.9	14.8	3.21	13.9	3.12	13.1	3.02	12.7	2.90	12.2	2.80	11.4	2.68
11	9.8	14.8	2.98	13.9	2.89	13.1	2.81	12.7	2.69	12.2	2.60	11.4	2.48	
13	11.8	14.8	2.78	13.9	2.70	13.1	2.62	12.7	2.51	12.2	2.43	11.4	2.32	
15	13.7	14.8	2.62	13.9	2.54	13.1	2.47	12.7	2.36	12.2	2.29	11.4	2.18	

6. Capacity Tables

Combination (%)	Outdoor air temp		Indoor air temp. °C DB											
			16		18		20		21		22		24	
	°C DB	°C WB	TC	PI	TC	PI	TC	PI	TC	PI	TC	PI	TC	PI
70	-19.8	-20	12.2	5.78	11.8	5.81	11.1	5.60	10.8	5.31	10.4	5.05	9.7	4.79
	-18.8	-19	12.5	5.81	11.8	5.70	11.1	5.49	10.8	5.21	10.4	4.95	9.7	4.70
	-16.7	-17	12.5	5.58	11.8	5.47	11.1	5.27	10.8	5.00	10.4	4.76	9.7	4.51
	-13.7	-15	12.5	5.25	11.8	5.14	11.1	4.95	10.8	4.70	10.4	4.48	9.7	4.25
	-11.8	-13	12.5	5.04	11.8	4.93	11.1	4.75	10.8	4.51	10.4	4.30	9.7	4.08
	-9.8	-11	12.5	4.82	11.8	4.71	11.1	4.54	10.8	4.31	10.4	4.12	9.7	3.90
	-9.5	-10	12.5	4.79	11.8	4.68	11.1	4.51	10.8	4.28	10.4	4.09	9.7	3.87
	-8.5	-9.1	12.5	4.68	11.8	4.57	11.1	4.40	10.8	4.18	10.4	4.00	9.7	3.78
	-7	-7.6	12.5	4.52	11.8	4.40	11.1	4.24	10.8	4.03	10.4	3.86	9.7	3.65
	-5	-5.6	12.5	4.30	11.8	4.18	11.1	4.03	10.8	3.83	10.4	3.67	9.7	3.47
	-3	-3.7	12.5	4.08	11.8	3.96	11.1	3.82	10.8	3.64	10.4	3.49	9.7	3.29
	0	-0.7	12.5	3.75	11.8	3.63	11.1	3.50	10.8	3.34	10.4	3.21	9.7	3.03
	3	2.2	12.5	3.42	11.8	3.30	11.1	3.19	10.8	3.04	10.4	2.93	9.7	2.76
	5	4.1	12.5	3.20	11.8	3.08	11.1	2.97	10.8	2.84	10.4	2.74	9.7	2.58
	7	6	12.5	2.98	11.8	2.86	11.1	2.76	10.8	2.64	10.4	2.56	9.7	2.40
	9	7.9	12.5	2.69	11.8	2.58	11.1	2.49	10.8	2.38	10.4	2.31	9.7	2.17
11	9.8	12.5	2.50	11.8	2.40	11.1	2.32	10.8	2.22	10.4	2.15	9.7	2.02	
13	11.8	12.5	2.34	11.8	2.25	11.1	2.17	10.8	2.07	10.4	2.01	9.7	1.89	
15	13.7	12.5	2.21	11.8	2.12	11.1	2.05	10.8	1.96	10.4	1.90	9.7	1.78	
60	-19.8	-20	10.8	5.73	10.2	5.50	9.6	5.20	9.2	4.91	8.9	4.65	8.3	4.39
	-18.8	-19	10.8	5.61	10.2	5.39	9.6	5.09	9.2	4.82	8.9	4.56	8.3	4.30
	-16.7	-17	10.8	5.37	10.2	5.15	9.6	4.87	9.2	4.61	8.9	4.36	8.3	4.12
	-13.7	-15	10.8	5.02	10.2	4.81	9.6	4.55	9.2	4.31	8.9	4.09	8.3	3.85
	-11.8	-13	10.8	4.81	10.2	4.60	9.6	4.35	9.2	4.12	8.9	3.91	8.3	3.68
	-9.8	-11	10.8	4.58	10.2	4.37	9.6	4.14	9.2	3.93	8.9	3.73	8.3	3.51
	-9.5	-10	10.8	4.54	10.2	4.34	9.6	4.11	9.2	3.90	8.9	3.70	8.3	3.48
	-8.5	-9.1	10.8	4.43	10.2	4.22	9.6	4.00	9.2	3.80	8.9	3.61	8.3	3.39
	-7	-7.6	10.8	4.25	10.2	4.05	9.6	3.84	9.2	3.65	8.9	3.47	8.3	3.26
	-5	-5.6	10.8	4.02	10.2	3.83	9.6	3.63	9.2	3.45	8.9	3.28	8.3	3.08
	-3	-3.7	10.8	3.79	10.2	3.60	9.6	3.42	9.2	3.25	8.9	3.10	8.3	2.91
	0	-0.7	10.8	3.45	10.2	3.26	9.6	3.10	9.2	2.96	8.9	2.82	8.3	2.64
	3	2.2	10.8	3.10	10.2	2.93	9.6	2.78	9.2	2.66	8.9	2.54	8.3	2.38
	5	4.1	10.8	2.87	10.2	2.70	9.6	2.57	9.2	2.46	8.9	2.36	8.3	2.20
	7	6	10.8	2.64	10.2	2.47	9.6	2.36	9.2	2.27	8.9	2.17	8.3	2.02
	9	7.9	10.8	2.36	10.2	2.21	9.6	2.10	9.2	2.02	8.9	1.94	8.3	1.80
11	9.8	10.8	2.20	10.2	2.06	9.6	1.96	9.2	1.89	8.9	1.81	8.3	1.68	
13	11.8	10.8	2.06	10.2	1.93	9.6	1.84	9.2	1.77	8.9	1.70	8.3	1.58	
15	13.7	10.8	1.95	10.2	1.82	9.6	1.74	9.2	1.67	8.9	1.60	8.3	1.49	
50	-19.8	-20	9.0	4.75	8.5	4.48	8.0	4.23	7.7	4.00	7.5	3.78	6.9	3.58
	-18.8	-19	9.0	4.65	8.5	4.38	8.0	4.15	7.7	3.92	7.5	3.71	6.9	3.50
	-16.7	-17	9.0	4.44	8.5	4.19	8.0	3.96	7.7	3.75	7.5	3.55	6.9	3.35
	-13.7	-15	9.0	4.15	8.5	3.91	8.0	3.71	7.7	3.50	7.5	3.33	6.9	3.14
	-11.8	-13	9.0	3.96	8.5	3.74	8.0	3.54	7.7	3.35	7.5	3.18	6.9	3.00
	-9.8	-11	9.0	3.77	8.5	3.55	8.0	3.37	7.7	3.19	7.5	3.03	6.9	2.86
	-9.5	-10	9.0	3.74	8.5	3.52	8.0	3.34	7.7	3.16	7.5	3.01	6.9	2.84
	-8.5	-9.1	9.0	3.64	8.5	3.43	8.0	3.26	7.7	3.08	7.5	2.93	6.9	2.76
	-7	-7.6	9.0	3.50	8.5	3.29	8.0	3.13	7.7	2.96	7.5	2.82	6.9	2.66
	-5	-5.6	9.0	3.30	8.5	3.11	8.0	2.96	7.7	2.80	7.5	2.67	6.9	2.51
	-3	-3.7	9.0	3.11	8.5	2.92	8.0	2.78	7.7	2.64	7.5	2.52	6.9	2.37
	0	-0.7	9.0	2.81	8.5	2.64	8.0	2.52	7.7	2.39	7.5	2.30	6.9	2.15
	3	2.2	9.0	2.52	8.5	2.37	8.0	2.27	7.7	2.15	7.5	2.07	6.9	1.94
	5	4.1	9.0	2.33	8.5	2.18	8.0	2.09	7.7	1.99	7.5	1.92	6.9	1.79
	7	6	9.0	2.13	8.5	1.99	8.0	1.92	7.7	1.82	7.5	1.77	6.9	1.65
	9	7.9	9.0	1.92	8.5	1.80	8.0	1.73	7.7	1.65	7.5	1.60	6.9	1.49
11	9.8	9.0	1.80	8.5	1.69	8.0	1.62	7.7	1.54	7.5	1.49	6.9	1.39	
13	11.8	9.0	1.69	8.5	1.58	8.0	1.52	7.7	1.45	7.5	1.40	6.9	1.31	
15	13.7	9.0	1.60	8.5	1.50	8.0	1.44	7.7	1.37	7.5	1.33	6.9	1.24	

Note

1. TC: Total Capacity(kW), PI : Power Input(kW, Comp. + Outdoor fan motor)
2. Capacity tables show the average value of conditions which may occur.

6. Capacity Tables

◆ ARUN060GSS0

Combination (%)	Outdoor air temp		Indoor air temp. °C DB											
			16		18		20		21		22		24	
	°C DB	°C WB	TC	PI	TC	PI	TC	PI	TC	PI	TC	PI	TC	PI
130	-19.8	-20	14.3	7.85	14.3	7.90	14.2	7.95	14.2	8.01	14.2	8.08	14.0	8.18
	-18.8	-19	14.7	7.88	14.7	7.93	14.6	7.98	14.6	8.05	14.6	8.11	14.3	8.21
	-16.7	-17	15.4	7.96	15.4	8.01	15.3	8.05	15.3	8.12	15.3	8.18	15.0	8.29
	-13.7	-15	16.4	8.06	16.4	8.11	16.3	8.15	16.3	8.22	16.3	8.29	16.0	7.91
	-11.8	-13	16.9	8.12	16.9	8.17	16.8	8.22	16.8	8.29	16.8	8.03	16.6	7.68
	-9.8	-11	17.5	8.19	17.5	8.24	17.4	8.29	17.4	8.01	17.4	7.76	17.2	7.43
	-9.5	-10	17.6	8.20	17.6	8.25	17.5	8.24	17.5	7.97	17.5	7.72	17.3	7.39
	-8.5	-9.1	17.9	8.23	17.9	8.29	17.8	8.10	17.8	7.83	17.7	7.59	17.7	7.27
	-7	-7.6	18.4	8.29	18.4	8.07	18.3	7.88	18.3	7.62	18.3	7.39	18.2	7.08
	-5	-5.6	19.1	7.99	19.1	7.78	19.0	7.59	19.0	7.34	19.0	7.12	18.8	6.83
	-3	-3.7	19.7	7.70	19.7	7.48	19.6	7.30	19.6	7.07	19.6	6.85	19.5	6.59
	0	-0.7	20.7	7.26	20.7	7.05	20.6	6.87	20.6	6.65	20.6	6.45	20.3	6.21
	3	2.2	21.7	6.81	21.7	6.61	21.6	6.43	21.6	6.23	21.6	6.05	20.3	5.84
	5	4.1	22.4	6.52	22.4	6.32	22.3	6.14	22.3	5.96	21.8	5.78	20.3	5.59
	7	6	23.1	6.23	23.1	6.03	22.9	5.85	22.6	5.68	21.8	5.51	20.3	5.35
9	7.9	23.3	5.98	23.3	5.78	23.2	5.62	22.6	5.45	21.8	5.29	20.3	5.13	
11	9.8	23.3	5.78	23.3	5.59	23.2	5.43	22.6	5.27	21.8	5.11	20.3	4.96	
13	11.8	23.3	5.56	23.3	5.39	23.2	5.23	22.6	5.08	21.8	4.93	20.3	4.78	
15	13.7	23.3	5.34	23.3	5.17	23.2	5.02	22.6	4.87	21.8	4.73	20.3	4.59	
120	-19.8	-20	14.2	7.90	14.2	7.95	14.1	8.01	14.1	8.08	14.1	8.18	13.9	8.25
	-18.8	-19	14.6	7.93	14.6	7.98	14.5	8.05	14.5	8.11	14.5	8.21	14.2	8.29
	-16.7	-17	15.3	8.01	15.3	8.05	15.2	8.12	15.2	8.18	15.2	8.29	14.9	8.05
	-13.7	-15	16.3	8.11	16.3	8.15	16.2	8.22	16.2	8.29	16.2	7.93	15.8	7.70
	-11.8	-13	16.8	8.17	16.8	8.22	16.7	8.29	16.7	8.03	16.7	7.70	16.5	7.49
	-9.8	-11	17.4	8.24	17.4	8.29	17.3	8.00	17.3	7.76	17.3	7.46	17.1	7.26
	-9.5	-10	17.5	8.25	17.5	8.24	17.4	7.96	17.4	7.72	17.4	7.42	17.2	7.23
	-8.5	-9.1	17.8	8.29	17.8	8.09	17.7	7.81	17.7	7.58	17.7	7.30	17.5	7.11
	-7	-7.6	18.3	8.05	18.3	7.86	18.2	7.60	18.2	7.38	18.2	7.12	18.0	6.94
	-5	-5.6	18.9	7.74	18.9	7.55	18.8	7.31	18.8	7.11	18.8	6.88	18.7	6.71
	-3	-3.7	19.6	7.43	19.6	7.24	19.5	7.03	19.5	6.84	19.5	6.64	19.1	6.48
	0	-0.7	20.6	6.96	20.6	6.78	20.5	6.60	20.5	6.44	20.5	6.28	19.1	6.14
	3	2.2	21.6	6.49	21.6	6.33	21.5	6.17	21.2	6.03	20.5	5.92	19.1	5.80
	5	4.1	22.2	6.18	22.2	6.02	21.9	5.89	21.2	5.76	20.5	5.68	19.1	5.57
	7	6	22.9	5.87	22.8	5.71	21.9	5.60	21.2	5.49	20.5	5.44	19.1	5.34
9	7.9	23.1	5.63	22.8	5.48	21.9	5.37	21.2	5.26	20.5	5.21	19.1	5.12	
11	9.8	23.1	5.43	22.8	5.28	21.9	5.18	21.2	5.08	20.5	5.03	19.1	4.94	
13	11.8	23.1	5.22	22.8	5.08	21.9	4.98	21.2	4.88	20.5	4.84	19.1	4.75	
15	13.7	23.1	5.00	22.8	4.86	21.9	4.77	21.2	4.68	20.5	4.63	19.1	4.55	
110	-19.8	-20	14.2	7.95	14.2	8.01	14.1	8.08	14.1	8.18	14.1	8.25	13.8	8.29
	-18.8	-19	14.5	7.98	14.5	8.05	14.4	8.11	14.4	8.21	14.4	8.29	14.1	8.16
	-16.7	-17	15.2	8.05	15.2	8.12	15.1	8.18	15.1	8.29	15.1	8.03	14.8	7.91
	-13.7	-15	16.2	8.15	16.2	8.22	16.1	8.29	16.1	7.90	16.1	7.67	16.1	7.54
	-11.8	-13	16.7	8.22	16.7	8.29	16.6	8.01	16.6	7.65	16.6	7.44	16.6	7.30
	-9.8	-11	17.3	8.29	17.3	7.97	17.2	7.72	17.2	7.39	17.2	7.19	17.1	7.06
	-9.5	-10	17.4	8.24	17.4	7.93	17.3	7.68	17.3	7.35	17.3	7.16	17.2	7.02
	-8.5	-9.1	17.7	8.06	17.7	7.77	17.6	7.53	17.6	7.23	17.6	7.04	17.2	6.90
	-7	-7.6	18.2	7.81	18.2	7.54	18.1	7.31	18.1	7.03	18.1	6.85	17.2	6.71
	-5	-5.6	18.8	7.47	18.8	7.22	18.7	7.02	18.7	6.77	18.4	6.61	17.2	6.47
	-3	-3.7	19.5	7.13	19.5	6.91	19.4	6.73	19.0	6.51	18.4	6.37	17.2	6.22
	0	-0.7	20.5	6.62	20.5	6.44	19.7	6.30	19.0	6.13	18.4	6.00	17.2	5.85
	3	2.2	21.5	6.11	21.0	5.97	19.7	5.86	19.0	5.74	18.4	5.64	17.2	5.49
	5	4.1	22.1	5.77	21.0	5.66	19.7	5.57	19.0	5.48	18.4	5.40	17.2	5.24
	7	6	22.2	5.43	21.0	5.35	19.7	5.29	19.0	5.22	18.4	5.15	17.2	4.99
9	7.9	22.2	5.18	21.0	5.10	19.7	5.04	19.0	4.98	18.4	4.92	17.2	4.77	
11	9.8	22.2	4.98	21.0	4.90	19.7	4.85	19.0	4.79	18.4	4.73	17.2	4.58	
13	11.8	22.2	4.76	21.0	4.69	19.7	4.64	19.0	4.58	18.4	4.52	17.2	4.38	
15	13.7	22.2	4.53	21.0	4.46	19.7	4.41	19.0	4.36	18.4	4.30	17.2	4.17	

6. Capacity Tables

Combination (%)	Outdoor air temp		Indoor air temp. °C DB											
			16		18		20		21		22		24	
	°C DB	°C WB	TC	PI	TC	PI	TC	PI	TC	PI	TC	PI	TC	PI
100	-19.8	-20	14.1	8.50	14.1	8.46	14.0	8.36	14.0	8.35	14.0	8.35	13.7	8.29
	-18.8	-19	14.4	8.48	14.3	8.44	14.3	8.40	14.3	8.33	14.3	8.29	14.0	8.14
	-16.7	-17	15.0	8.44	15.0	8.39	15.0	8.47	14.9	8.29	14.9	7.98	14.6	7.84
	-13.7	-15	16.1	8.37	16.1	8.33	16.0	8.29	16.0	7.84	16.0	7.55	15.7	7.40
	-11.8	-13	16.6	8.33	16.5	8.29	16.5	7.98	16.5	7.56	16.5	7.28	15.7	7.13
	-9.8	-11	17.2	8.29	17.2	7.95	17.1	7.67	17.1	7.27	16.8	6.99	15.7	6.84
	-9.5	-10	17.3	8.23	17.3	7.89	17.2	7.62	17.2	7.22	16.8	6.95	15.7	6.79
	-8.5	-9.1	17.6	8.05	17.6	7.72	17.5	7.46	17.4	7.07	16.8	6.81	15.7	6.65
	-7	-7.6	18.4	7.78	18.3	7.47	18.0	7.22	17.4	6.85	16.8	6.59	15.7	6.43
	-5	-5.6	19.2	7.42	19.0	7.13	18.0	6.90	17.4	6.56	16.8	6.30	15.7	6.14
	-3	-3.7	19.8	7.06	19.2	6.79	18.0	6.59	17.4	6.26	16.8	6.01	15.7	5.85
	0	-0.7	20.3	6.52	19.2	6.28	18.0	6.11	17.4	5.82	16.8	5.58	15.7	5.42
	3	2.2	20.3	5.98	19.2	5.77	18.0	5.63	17.4	5.37	16.8	5.15	15.7	4.98
	5	4.1	20.3	5.61	19.2	5.43	18.0	5.32	17.4	5.08	16.8	4.86	15.7	4.69
	7	6	20.3	5.25	19.2	5.09	18.0	5.00	17.4	4.78	16.8	4.58	15.7	4.40
	9	7.9	20.3	4.98	19.2	4.82	18.0	4.74	17.4	4.54	16.8	4.34	15.7	4.17
11	9.8	20.3	4.75	19.2	4.60	18.0	4.52	17.4	4.32	16.8	4.14	15.7	3.98	
13	11.8	20.3	4.50	19.2	4.36	18.0	4.29	17.4	4.10	16.8	3.92	15.7	3.77	
15	13.7	20.3	4.24	19.2	4.11	18.0	4.04	17.4	3.86	16.8	3.70	15.7	3.56	
90	-19.8	-20	14.0	7.82	14.0	7.92	13.9	7.99	13.9	8.03	13.9	7.77	13.7	7.40
	-18.8	-19	14.4	7.85	14.3	7.96	14.3	8.03	14.3	7.89	14.3	7.63	14.0	7.27
	-16.7	-17	15.0	7.93	15.0	8.03	15.0	7.74	15.0	7.61	15.0	7.36	14.3	7.00
	-13.7	-15	16.1	8.03	16.1	7.60	16.0	7.34	16.0	7.20	15.4	6.96	14.3	6.62
	-11.8	-13	16.6	7.73	16.5	7.33	16.5	7.08	16.0	6.94	15.4	6.71	14.3	6.38
	-9.8	-11	17.2	7.42	17.2	7.05	16.5	6.81	16.0	6.66	15.4	6.45	14.3	6.13
	-9.5	-10	17.3	7.37	17.3	7.00	16.5	6.77	16.0	6.62	15.4	6.41	14.3	6.09
	-8.5	-9.1	17.6	7.22	17.5	6.86	16.5	6.63	16.0	6.49	15.4	6.28	14.3	5.96
	-7	-7.6	18.4	6.98	17.5	6.65	16.5	6.43	16.0	6.28	15.4	6.08	14.3	5.77
	-5	-5.6	18.6	6.67	17.5	6.36	16.5	6.16	16.0	6.01	15.4	5.82	14.3	5.52
	-3	-3.7	18.6	6.36	17.5	6.08	16.5	5.88	16.0	5.74	15.4	5.56	14.3	5.27
	0	-0.7	18.6	5.89	17.5	5.65	16.5	5.48	16.0	5.33	15.4	5.16	14.3	4.89
	3	2.2	18.6	5.42	17.5	5.22	16.5	5.07	16.0	4.92	15.4	4.77	14.3	4.51
	5	4.1	18.6	5.11	17.5	4.94	16.5	4.80	16.0	4.65	15.4	4.51	14.3	4.26
	7	6	18.6	4.80	17.5	4.65	16.5	4.53	16.0	4.37	15.4	4.24	14.3	4.00
	9	7.9	18.6	4.51	17.5	4.37	16.5	4.26	16.0	4.11	15.4	3.99	14.3	3.76
11	9.8	18.6	4.23	17.5	4.10	16.5	3.99	16.0	3.85	15.4	3.74	14.3	3.52	
13	11.8	18.6	3.94	17.5	3.82	16.5	3.71	16.0	3.59	15.4	3.48	14.3	3.28	
15	13.7	18.6	3.65	17.5	3.54	16.5	3.44	16.0	3.33	15.4	3.23	14.3	3.04	
80	-19.8	-20	13.9	6.91	13.9	7.01	13.9	7.12	13.9	6.88	13.8	6.56	12.8	6.25
	-18.8	-19	14.2	6.95	14.2	7.12	14.2	7.00	14.2	6.76	13.8	6.45	12.8	6.15
	-16.7	-17	14.7	7.12	14.7	6.86	14.7	6.74	14.3	6.51	13.8	6.22	12.8	5.92
	-13.7	-15	14.7	6.74	14.7	6.50	14.7	6.38	14.3	6.16	13.8	5.88	12.8	5.61
	-11.8	-13	15.1	6.49	14.7	6.26	14.7	6.14	14.3	5.93	13.8	5.67	12.8	5.40
	-9.8	-11	15.7	6.24	15.3	6.02	14.7	5.90	14.3	5.69	13.8	5.45	12.8	5.19
	-9.5	-10	15.8	6.20	15.4	5.98	14.7	5.86	14.3	5.66	13.8	5.41	12.8	5.16
	-8.5	-9.1	16.2	6.07	15.7	5.86	14.7	5.74	14.3	5.54	13.8	5.30	12.8	5.05
	-7	-7.6	16.6	5.88	15.7	5.68	14.7	5.56	14.3	5.36	13.8	5.13	12.8	4.90
	-5	-5.6	16.6	5.62	15.7	5.43	14.7	5.32	14.3	5.12	13.8	4.91	12.8	4.68
	-3	-3.7	16.6	5.37	15.7	5.19	14.7	5.07	14.3	4.88	13.8	4.69	12.8	4.47
	0	-0.7	16.6	4.98	15.7	4.82	14.7	4.71	14.3	4.53	13.8	4.35	12.8	4.15
	3	2.2	16.6	4.60	15.7	4.46	14.7	4.34	14.3	4.17	13.8	4.02	12.8	3.83
	5	4.1	16.6	4.34	15.7	4.21	14.7	4.10	14.3	3.93	13.8	3.79	12.8	3.62
	7	6	16.6	4.09	15.7	3.97	14.7	3.85	14.3	3.69	13.8	3.57	12.8	3.41
	9	7.9	16.6	3.84	15.7	3.73	14.7	3.62	14.3	3.47	13.8	3.35	12.8	3.20
11	9.8	16.6	3.56	15.7	3.46	14.7	3.36	14.3	3.22	13.8	3.11	12.8	2.97	
13	11.8	16.6	3.33	15.7	3.23	14.7	3.13	14.3	3.00	13.8	2.91	12.8	2.77	
15	13.7	16.6	3.13	15.7	3.04	14.7	2.95	14.3	2.83	13.8	2.74	12.8	2.61	

6. Capacity Tables

Combination (%)	Outdoor air temp		Indoor air temp. °C DB											
			16		18		20		21		22		24	
	°C DB	°C WB	TC	PI	TC	PI	TC	PI	TC	PI	TC	PI	TC	PI
70	-19.8	-20	13.8	6.92	13.3	6.95	12.5	6.70	12.1	6.36	11.8	6.04	11.0	5.73
	-18.8	-19	14.1	6.95	13.3	6.82	12.5	6.57	12.1	6.24	11.8	5.93	11.0	5.62
	-16.7	-17	14.1	6.68	13.3	6.54	12.5	6.31	12.1	5.98	11.8	5.69	11.0	5.40
	-13.7	-15	14.1	6.28	13.3	6.15	12.5	5.93	12.1	5.63	11.8	5.36	11.0	5.08
	-11.8	-13	14.1	6.03	13.3	5.90	12.5	5.69	12.1	5.40	11.8	5.15	11.0	4.88
	-9.8	-11	14.1	5.77	13.3	5.63	12.5	5.43	12.1	5.16	11.8	4.93	11.0	4.66
	-9.5	-10	14.1	5.73	13.3	5.59	12.5	5.39	12.1	5.12	11.8	4.89	11.0	4.63
	-8.5	-9.1	14.1	5.60	13.3	5.46	12.5	5.27	12.1	5.01	11.8	4.78	11.0	4.53
	-7	-7.6	14.1	5.40	13.3	5.26	12.5	5.08	12.1	4.83	11.8	4.62	11.0	4.37
	-5	-5.6	14.1	5.14	13.3	5.00	12.5	4.82	12.1	4.59	11.8	4.39	11.0	4.15
	-3	-3.7	14.1	4.88	13.3	4.74	12.5	4.57	12.1	4.35	11.8	4.17	11.0	3.94
	0	-0.7	14.1	4.48	13.3	4.34	12.5	4.19	12.1	3.99	11.8	3.84	11.0	3.62
	3	2.2	14.1	4.09	13.3	3.95	12.5	3.81	12.1	3.63	11.8	3.50	11.0	3.30
	5	4.1	14.1	3.82	13.3	3.68	12.5	3.56	12.1	3.39	11.8	3.28	11.0	3.09
	7	6	14.1	3.56	13.3	3.42	12.5	3.30	12.1	3.15	11.8	3.06	11.0	2.88
	9	7.9	14.1	3.22	13.3	3.09	12.5	2.98	12.1	2.85	11.8	2.76	11.0	2.60
11	9.8	14.1	2.99	13.3	2.87	12.5	2.78	12.1	2.65	11.8	2.57	11.0	2.42	
13	11.8	14.1	2.80	13.3	2.69	12.5	2.60	12.1	2.48	11.8	2.41	11.0	2.26	
15	13.7	14.1	2.64	13.3	2.53	12.5	2.45	12.1	2.34	11.8	2.27	11.0	2.13	
60	-19.8	-20	12.1	6.85	11.5	6.58	10.8	6.22	10.4	5.88	10.0	5.56	9.4	5.25
	-18.8	-19	12.1	6.71	11.5	6.44	10.8	6.09	10.4	5.76	10.0	5.45	9.4	5.15
	-16.7	-17	12.1	6.42	11.5	6.16	10.8	5.82	10.4	5.51	10.0	5.22	9.4	4.93
	-13.7	-15	12.1	6.01	11.5	5.76	10.8	5.44	10.4	5.16	10.0	4.89	9.4	4.61
	-11.8	-13	12.1	5.75	11.5	5.50	10.8	5.20	10.4	4.93	10.0	4.68	9.4	4.41
	-9.8	-11	12.1	5.47	11.5	5.23	10.8	4.95	10.4	4.70	10.0	4.46	9.4	4.20
	-9.5	-10	12.1	5.43	11.5	5.19	10.8	4.91	10.4	4.66	10.0	4.42	9.4	4.16
	-8.5	-9.1	12.1	5.29	11.5	5.05	10.8	4.78	10.4	4.54	10.0	4.31	9.4	4.06
	-7	-7.6	12.1	5.09	11.5	4.85	10.8	4.59	10.4	4.37	10.0	4.15	9.4	3.90
	-5	-5.6	12.1	4.81	11.5	4.58	10.8	4.34	10.4	4.13	10.0	3.93	9.4	3.69
	-3	-3.7	12.1	4.54	11.5	4.31	10.8	4.09	10.4	3.89	10.0	3.71	9.4	3.48
	0	-0.7	12.1	4.12	11.5	3.90	10.8	3.71	10.4	3.54	10.0	3.37	9.4	3.16
	3	2.2	12.1	3.71	11.5	3.50	10.8	3.33	10.4	3.18	10.0	3.04	9.4	2.84
	5	4.1	12.1	3.43	11.5	3.23	10.8	3.07	10.4	2.95	10.0	2.82	9.4	2.63
	7	6	12.1	3.16	11.5	2.96	10.8	2.82	10.4	2.71	10.0	2.60	9.4	2.42
	9	7.9	12.1	2.82	11.5	2.64	10.8	2.52	10.4	2.42	10.0	2.32	9.4	2.16
11	9.8	12.1	2.63	11.5	2.46	10.8	2.35	10.4	2.26	10.0	2.17	9.4	2.01	
13	11.8	12.1	2.47	11.5	2.31	10.8	2.20	10.4	2.12	10.0	2.03	9.4	1.89	
15	13.7	12.1	2.33	11.5	2.18	10.8	2.08	10.4	2.00	10.0	1.92	9.4	1.78	
50	-19.8	-20	10.1	5.68	9.5	5.36	9.0	5.06	8.7	4.78	8.4	4.53	7.8	4.28
	-18.8	-19	10.1	5.56	9.5	5.24	9.0	4.96	8.7	4.69	8.4	4.44	7.8	4.19
	-16.7	-17	10.1	5.31	9.5	5.01	9.0	4.74	8.7	4.48	8.4	4.25	7.8	4.01
	-13.7	-15	10.1	4.96	9.5	4.68	9.0	4.43	8.7	4.19	8.4	3.98	7.8	3.75
	-11.8	-13	10.1	4.74	9.5	4.47	9.0	4.24	8.7	4.01	8.4	3.81	7.8	3.59
	-9.8	-11	10.1	4.51	9.5	4.25	9.0	4.03	8.7	3.81	8.4	3.63	7.8	3.42
	-9.5	-10	10.1	4.47	9.5	4.21	9.0	4.00	8.7	3.78	8.4	3.60	7.8	3.39
	-8.5	-9.1	10.1	4.36	9.5	4.10	9.0	3.90	8.7	3.69	8.4	3.51	7.8	3.31
	-7	-7.6	10.1	4.18	9.5	3.94	9.0	3.74	8.7	3.54	8.4	3.38	7.8	3.18
	-5	-5.6	10.1	3.95	9.5	3.72	9.0	3.54	8.7	3.35	8.4	3.20	7.8	3.00
	-3	-3.7	10.1	3.72	9.5	3.49	9.0	3.33	8.7	3.15	8.4	3.02	7.8	2.83
	0	-0.7	10.1	3.37	9.5	3.16	9.0	3.02	8.7	2.86	8.4	2.75	7.8	2.58
	3	2.2	10.1	3.01	9.5	2.83	9.0	2.71	8.7	2.57	8.4	2.48	7.8	2.32
	5	4.1	10.1	2.78	9.5	2.61	9.0	2.50	8.7	2.38	8.4	2.30	7.8	2.15
	7	6	10.1	2.55	9.5	2.39	9.0	2.30	8.7	2.18	8.4	2.12	7.8	1.97
	9	7.9	10.1	2.30	9.5	2.15	9.0	2.08	8.7	1.97	8.4	1.91	7.8	1.78
11	9.8	10.1	2.15	9.5	2.02	9.0	1.94	8.7	1.84	8.4	1.79	7.8	1.67	
13	11.8	10.1	2.02	9.5	1.89	9.0	1.82	8.7	1.73	8.4	1.68	7.8	1.57	
15	13.7	10.1	1.91	9.5	1.79	9.0	1.72	8.7	1.64	8.4	1.59	7.8	1.48	

Note

1. TC: Total Capacity(kW), PI : Power Input(kW, Comp. + Outdoor fan motor)
2. Capacity tables show the average value of conditions which may occur.

6. Capacity Tables

6.2.2 3 Phase / Heat Pump

◆ ARUN040LSS0

Combination (%)	Outdoor air temp		Indoor air temp. °C DB											
			16		18		20		21		22		24	
	°C DB	°C WB	TC	PI	TC	PI	TC	PI	TC	PI	TC	PI	TC	PI
130	-19.8	-20	10.0	4.32	10.0	4.35	9.9	4.37	9.9	4.41	9.9	4.44	9.7	4.50
	-18.8	-19	10.2	4.34	10.2	4.36	10.1	4.39	10.1	4.43	10.1	4.46	9.9	4.52
	-16.7	-17	10.7	4.38	10.7	4.40	10.6	4.43	10.6	4.47	10.6	4.50	10.4	4.56
	-13.7	-15	11.4	4.43	11.4	4.46	11.3	4.48	11.3	4.52	11.3	4.56	11.1	4.35
	-11.8	-13	11.8	4.47	11.8	4.50	11.7	4.52	11.7	4.56	11.7	4.42	11.5	4.22
	-9.8	-11	12.1	4.50	12.1	4.53	12.1	4.56	12.1	4.40	12.1	4.27	12.0	4.09
	-9.5	-10	12.2	4.51	12.2	4.54	12.1	4.53	12.1	4.38	12.1	4.25	12.0	4.07
	-8.5	-9.1	12.4	4.53	12.4	4.56	12.4	4.45	12.4	4.31	12.3	4.17	12.3	4.00
	-7	-7.6	12.8	4.56	12.8	4.44	12.7	4.33	12.7	4.19	12.7	4.06	12.6	3.90
	-5	-5.6	13.3	4.40	13.3	4.28	13.2	4.17	13.2	4.04	13.2	3.92	13.1	3.76
	-3	-3.7	13.7	4.23	13.7	4.12	13.6	4.02	13.6	3.89	13.6	3.77	13.5	3.62
	0	-0.7	14.4	3.99	14.4	3.88	14.3	3.78	14.3	3.66	14.3	3.55	14.1	3.42
	3	2.2	15.1	3.75	15.1	3.63	15.0	3.54	15.0	3.43	15.0	3.33	14.1	3.21
	5	4.1	15.6	3.59	15.6	3.47	15.5	3.38	15.5	3.28	15.2	3.18	14.1	3.08
	7	6	16.0	3.42	16.0	3.31	15.9	3.22	15.7	3.12	15.2	3.03	14.1	2.94
	9	7.9	16.2	3.29	16.2	3.18	16.1	3.09	15.7	3.00	15.2	2.91	14.1	2.82
11	9.8	16.2	3.18	16.2	3.07	16.1	2.99	15.7	2.90	15.2	2.81	14.1	2.73	
13	11.8	16.2	3.06	16.2	2.96	16.1	2.88	15.7	2.79	15.2	2.71	14.1	2.63	
15	13.7	16.2	2.94	16.2	2.84	16.1	2.76	15.7	2.68	15.2	2.60	14.1	2.52	
120	-19.8	-20	9.9	4.35	9.9	4.37	9.8	4.41	9.8	4.44	9.8	4.50	9.6	4.54
	-18.8	-19	10.1	4.36	10.1	4.39	10.1	4.43	10.1	4.46	10.1	4.52	9.8	4.56
	-16.7	-17	10.6	4.40	10.6	4.43	10.5	4.47	10.5	4.50	10.5	4.56	10.3	4.43
	-13.7	-15	11.3	4.46	11.3	4.48	11.2	4.52	11.2	4.56	11.2	4.36	11.0	4.24
	-11.8	-13	11.7	4.50	11.7	4.52	11.6	4.56	11.6	4.42	11.6	4.23	11.4	4.12
	-9.8	-11	12.1	4.53	12.1	4.56	12.0	4.40	12.0	4.27	12.0	4.10	11.9	3.99
	-9.5	-10	12.1	4.54	12.1	4.53	12.1	4.38	12.1	4.25	12.1	4.08	12.0	3.97
	-8.5	-9.1	12.4	4.56	12.4	4.45	12.3	4.30	12.3	4.17	12.3	4.02	12.2	3.91
	-7	-7.6	12.7	4.43	12.7	4.32	12.6	4.18	12.6	4.06	12.6	3.92	12.5	3.82
	-5	-5.6	13.2	4.26	13.2	4.15	13.1	4.02	13.1	3.91	13.1	3.78	13.0	3.69
	-3	-3.7	13.6	4.09	13.6	3.98	13.5	3.87	13.5	3.76	13.5	3.65	13.3	3.57
	0	-0.7	14.3	3.83	14.3	3.73	14.2	3.63	14.2	3.54	14.2	3.45	13.3	3.38
	3	2.2	15.0	3.57	15.0	3.48	14.9	3.39	14.7	3.32	14.3	3.26	13.3	3.19
	5	4.1	15.5	3.40	15.5	3.31	15.2	3.24	14.7	3.17	14.3	3.12	13.3	3.06
	7	6	15.9	3.23	15.9	3.14	15.2	3.08	14.7	3.02	14.3	2.99	13.3	2.94
	9	7.9	16.0	3.10	15.9	3.01	15.2	2.95	14.7	2.90	14.3	2.87	13.3	2.82
11	9.8	16.0	2.99	15.9	2.91	15.2	2.85	14.7	2.79	14.3	2.77	13.3	2.72	
13	11.8	16.0	2.87	15.9	2.79	15.2	2.74	14.7	2.69	14.3	2.66	13.3	2.61	
15	13.7	16.0	2.75	15.9	2.68	15.2	2.62	14.7	2.57	14.3	2.55	13.3	2.50	
110	-19.8	-20	9.8	4.37	9.8	4.41	9.8	4.44	9.8	4.50	9.8	4.54	9.6	4.56
	-18.8	-19	10.1	4.39	10.1	4.43	10.0	4.46	10.0	4.52	10.0	4.56	9.8	4.49
	-16.7	-17	10.5	4.43	10.5	4.47	10.5	4.50	10.5	4.56	10.5	4.42	10.3	4.35
	-13.7	-15	11.2	4.48	11.2	4.52	11.2	4.56	11.2	4.34	11.2	4.22	11.2	4.15
	-11.8	-13	11.6	4.52	11.6	4.56	11.5	4.41	11.5	4.21	11.5	4.09	11.5	4.02
	-9.8	-11	12.0	4.56	12.0	4.39	11.9	4.25	11.9	4.07	11.9	3.96	11.9	3.88
	-9.5	-10	12.1	4.53	12.1	4.36	12.0	4.22	12.0	4.05	12.0	3.94	11.9	3.86
	-8.5	-9.1	12.3	4.44	12.3	4.27	12.2	4.14	12.2	3.97	12.2	3.87	11.9	3.79
	-7	-7.6	12.6	4.30	12.6	4.14	12.6	4.02	12.6	3.87	12.6	3.77	11.9	3.69
	-5	-5.6	13.1	4.11	13.1	3.97	13.0	3.86	13.0	3.73	12.8	3.64	11.9	3.56
	-3	-3.7	13.5	3.92	13.5	3.80	13.5	3.70	13.2	3.58	12.8	3.50	11.9	3.42
	0	-0.7	14.2	3.64	14.2	3.54	13.7	3.46	13.2	3.37	12.8	3.30	11.9	3.22
	3	2.2	14.9	3.36	14.6	3.28	13.7	3.23	13.2	3.16	12.8	3.10	11.9	3.02
	5	4.1	15.4	3.17	14.6	3.11	13.7	3.07	13.2	3.01	12.8	2.97	11.9	2.88
	7	6	15.4	2.98	14.6	2.94	13.7	2.91	13.2	2.87	12.8	2.83	11.9	2.75
	9	7.9	15.4	2.85	14.6	2.81	13.7	2.77	13.2	2.74	12.8	2.71	11.9	2.62
11	9.8	15.4	2.74	14.6	2.70	13.7	2.67	13.2	2.63	12.8	2.60	11.9	2.52	
13	11.8	15.4	2.62	14.6	2.58	13.7	2.55	13.2	2.52	12.8	2.49	11.9	2.41	
15	13.7	15.4	2.49	14.6	2.46	13.7	2.43	13.2	2.40	12.8	2.37	11.9	2.29	

6. Capacity Tables

Combination (%)	Outdoor air temp		Indoor air temp. °C DB											
			16		18		20		21		22		24	
	°C DB	°C WB	TC	PI	TC	PI	TC	PI	TC	PI	TC	PI	TC	PI
100	-19.8	-20	9.8	4.68	9.8	4.65	9.7	4.60	9.7	4.59	9.7	4.59	9.5	4.56
	-18.8	-19	10.0	4.66	10.0	4.64	10.0	4.62	10.0	4.58	10.0	4.56	9.8	4.48
	-16.7	-17	10.4	4.64	10.4	4.62	10.4	4.66	10.4	4.56	10.4	4.39	10.2	4.31
	-13.7	-15	11.2	4.60	11.2	4.58	11.1	4.56	11.1	4.31	11.1	4.15	10.9	4.07
	-11.8	-13	11.5	4.58	11.5	4.56	11.5	4.39	11.5	4.16	11.5	4.00	10.9	3.92
	-9.8	-11	11.9	4.56	11.9	4.37	11.9	4.22	11.9	4.00	11.7	3.85	10.9	3.76
	-9.5	-10	12.0	4.53	12.0	4.34	11.9	4.19	11.9	3.97	11.7	3.82	10.9	3.74
	-8.5	-9.1	12.2	4.43	12.2	4.25	12.2	4.10	12.1	3.89	11.7	3.74	10.9	3.66
	-7	-7.6	12.8	4.28	12.7	4.11	12.5	3.97	12.1	3.77	11.7	3.62	10.9	3.54
	-5	-5.6	13.3	4.08	13.2	3.92	12.5	3.80	12.1	3.61	11.7	3.47	10.9	3.38
	-3	-3.7	13.7	3.88	13.3	3.73	12.5	3.62	12.1	3.44	11.7	3.31	10.9	3.22
	0	-0.7	14.1	3.58	13.3	3.45	12.5	3.36	12.1	3.20	11.7	3.07	10.9	2.98
	3	2.2	14.1	3.29	13.3	3.17	12.5	3.10	12.1	2.96	11.7	2.83	10.9	2.74
	5	4.1	14.1	3.09	13.3	2.99	12.5	2.92	12.1	2.79	11.7	2.68	10.9	2.58
	7	6	14.1	2.89	13.3	2.80	12.5	2.75	12.1	2.63	11.7	2.52	10.9	2.42
	9	7.9	14.1	2.74	13.3	2.65	12.5	2.61	12.1	2.49	11.7	2.39	10.9	2.30
11	9.8	14.1	2.61	13.3	2.53	12.5	2.49	12.1	2.38	11.7	2.28	10.9	2.19	
13	11.8	14.1	2.48	13.3	2.40	12.5	2.36	12.1	2.25	11.7	2.16	10.9	2.07	
15	13.7	14.1	2.33	13.3	2.26	12.5	2.22	12.1	2.13	11.7	2.03	10.9	1.96	
90	-19.8	-20	9.7	4.30	9.7	4.36	9.7	4.40	9.7	4.42	9.7	4.27	9.5	4.07
	-18.8	-19	10.0	4.32	10.0	4.38	9.9	4.42	9.9	4.34	9.9	4.20	9.7	4.00
	-16.7	-17	10.4	4.36	10.4	4.42	10.4	4.26	10.4	4.18	10.4	4.05	10.0	3.85
	-13.7	-15	11.2	4.42	11.2	4.18	11.1	4.04	11.1	3.96	10.7	3.83	10.0	3.64
	-11.8	-13	11.5	4.25	11.5	4.03	11.4	3.89	11.1	3.82	10.7	3.69	10.0	3.51
	-9.8	-11	11.9	4.08	11.9	3.88	11.4	3.74	11.1	3.67	10.7	3.55	10.0	3.37
	-9.5	-10	12.0	4.06	12.0	3.85	11.4	3.72	11.1	3.64	10.7	3.53	10.0	3.35
	-8.5	-9.1	12.2	3.97	12.1	3.77	11.4	3.65	11.1	3.57	10.7	3.45	10.0	3.28
	-7	-7.6	12.8	3.84	12.1	3.66	11.4	3.54	11.1	3.46	10.7	3.35	10.0	3.18
	-5	-5.6	12.9	3.67	12.1	3.50	11.4	3.39	11.1	3.31	10.7	3.20	10.0	3.04
	-3	-3.7	12.9	3.50	12.1	3.34	11.4	3.24	11.1	3.16	10.7	3.06	10.0	2.90
	0	-0.7	12.9	3.24	12.1	3.11	11.4	3.01	11.1	2.93	10.7	2.84	10.0	2.69
	3	2.2	12.9	2.98	12.1	2.87	11.4	2.79	11.1	2.71	10.7	2.62	10.0	2.48
	5	4.1	12.9	2.81	12.1	2.72	11.4	2.64	11.1	2.56	10.7	2.48	10.0	2.34
	7	6	12.9	2.64	12.1	2.56	11.4	2.49	11.1	2.41	10.7	2.33	10.0	2.20
	9	7.9	12.9	2.48	12.1	2.41	11.4	2.34	11.1	2.26	10.7	2.19	10.0	2.07
11	9.8	12.9	2.32	12.1	2.25	11.4	2.19	11.1	2.12	10.7	2.05	10.0	1.94	
13	11.8	12.9	2.17	12.1	2.10	11.4	2.04	11.1	1.97	10.7	1.91	10.0	1.81	
15	13.7	12.9	2.01	12.1	1.95	11.4	1.89	11.1	1.83	10.7	1.77	10.0	1.67	
80	-19.8	-20	9.6	3.80	9.6	3.86	9.6	3.92	9.6	3.78	9.6	3.61	8.9	3.44
	-18.8	-19	9.9	3.82	9.9	3.92	9.9	3.85	9.9	3.72	9.6	3.55	8.9	3.38
	-16.7	-17	10.2	3.92	10.2	3.77	10.2	3.71	9.9	3.58	9.6	3.42	8.9	3.26
	-13.7	-15	10.2	3.70	10.2	3.57	10.2	3.51	9.9	3.39	9.6	3.23	8.9	3.08
	-11.8	-13	10.5	3.57	10.2	3.45	10.2	3.38	9.9	3.26	9.6	3.12	8.9	2.97
	-9.8	-11	10.9	3.43	10.6	3.31	10.2	3.25	9.9	3.13	9.6	3.00	8.9	2.86
	-9.5	-10	11.0	3.41	10.7	3.29	10.2	3.23	9.9	3.11	9.6	2.98	8.9	2.84
	-8.5	-9.1	11.2	3.34	10.9	3.22	10.2	3.16	9.9	3.05	9.6	2.92	8.9	2.78
	-7	-7.6	11.6	3.23	10.9	3.12	10.2	3.06	9.9	2.95	9.6	2.82	8.9	2.69
	-5	-5.6	11.6	3.09	10.9	2.99	10.2	2.92	9.9	2.82	9.6	2.70	8.9	2.58
	-3	-3.7	11.6	2.95	10.9	2.85	10.2	2.79	9.9	2.69	9.6	2.58	8.9	2.46
	0	-0.7	11.6	2.74	10.9	2.65	10.2	2.59	9.9	2.49	9.6	2.39	8.9	2.28
	3	2.2	11.6	2.53	10.9	2.45	10.2	2.39	9.9	2.29	9.6	2.21	8.9	2.11
	5	4.1	11.6	2.39	10.9	2.32	10.2	2.25	9.9	2.16	9.6	2.09	8.9	1.99
	7	6	11.6	2.25	10.9	2.18	10.2	2.12	9.9	2.03	9.6	1.96	8.9	1.88
	9	7.9	11.6	2.11	10.9	2.05	10.2	1.99	9.9	1.91	9.6	1.84	8.9	1.76
11	9.8	11.6	1.96	10.9	1.90	10.2	1.85	9.9	1.77	9.6	1.71	8.9	1.63	
13	11.8	11.6	1.83	10.9	1.78	10.2	1.72	9.9	1.65	9.6	1.60	8.9	1.53	
15	13.7	11.6	1.72	10.9	1.67	10.2	1.62	9.9	1.56	9.6	1.50	8.9	1.44	

6. Capacity Tables

Combination (%)	Outdoor air temp		Indoor air temp. °C DB											
			16		18		20		21		22		24	
	°C DB	°C WB	TC	PI	TC	PI	TC	PI	TC	PI	TC	PI	TC	PI
70	-19.8	-20	9.6	3.81	9.3	3.82	8.7	3.68	8.4	3.50	8.2	3.32	7.6	3.15
	-18.8	-19	9.8	3.82	9.3	3.75	8.7	3.61	8.4	3.43	8.2	3.26	7.6	3.09
	-16.7	-17	9.8	3.67	9.3	3.60	8.7	3.47	8.4	3.29	8.2	3.13	7.6	2.97
	-13.7	-15	9.8	3.46	9.3	3.38	8.7	3.26	8.4	3.09	8.2	2.95	7.6	2.79
	-11.8	-13	9.8	3.32	9.3	3.24	8.7	3.13	8.4	2.97	8.2	2.83	7.6	2.68
	-9.8	-11	9.8	3.17	9.3	3.10	8.7	2.99	8.4	2.84	8.2	2.71	7.6	2.57
	-9.5	-10	9.8	3.15	9.3	3.08	8.7	2.97	8.4	2.82	8.2	2.69	7.6	2.55
	-8.5	-9.1	9.8	3.08	9.3	3.00	8.7	2.90	8.4	2.75	8.2	2.63	7.6	2.49
	-7	-7.6	9.8	2.97	9.3	2.90	8.7	2.79	8.4	2.65	8.2	2.54	7.6	2.40
	-5	-5.6	9.8	2.83	9.3	2.75	8.7	2.65	8.4	2.52	8.2	2.42	7.6	2.28
	-3	-3.7	9.8	2.68	9.3	2.61	8.7	2.51	8.4	2.39	8.2	2.29	7.6	2.17
	0	-0.7	9.8	2.46	9.3	2.39	8.7	2.30	8.4	2.19	8.2	2.11	7.6	1.99
	3	2.2	9.8	2.25	9.3	2.17	8.7	2.10	8.4	2.00	8.2	1.93	7.6	1.82
	5	4.1	9.8	2.10	9.3	2.02	8.7	1.96	8.4	1.87	8.2	1.80	7.6	1.70
	7	6	9.8	1.96	9.3	1.88	8.7	1.82	8.4	1.73	8.2	1.68	7.6	1.58
9	7.9	9.8	1.77	9.3	1.70	8.7	1.64	8.4	1.57	8.2	1.52	7.6	1.43	
11	9.8	9.8	1.65	9.3	1.58	8.7	1.53	8.4	1.46	8.2	1.41	7.6	1.33	
13	11.8	9.8	1.54	9.3	1.48	8.7	1.43	8.4	1.36	8.2	1.32	7.6	1.24	
15	13.7	9.8	1.45	9.3	1.39	8.7	1.35	8.4	1.29	8.2	1.25	7.6	1.17	
60	-19.8	-20	8.4	3.77	8.0	3.62	7.5	3.42	7.2	3.23	7.0	3.06	6.5	2.89
	-18.8	-19	8.4	3.69	8.0	3.54	7.5	3.35	7.2	3.17	7.0	3.00	6.5	2.83
	-16.7	-17	8.4	3.53	8.0	3.39	7.5	3.20	7.2	3.03	7.0	2.87	6.5	2.71
	-13.7	-15	8.4	3.31	8.0	3.17	7.5	2.99	7.2	2.84	7.0	2.69	6.5	2.53
	-11.8	-13	8.4	3.16	8.0	3.02	7.5	2.86	7.2	2.71	7.0	2.57	6.5	2.42
	-9.8	-11	8.4	3.01	8.0	2.88	7.5	2.72	7.2	2.58	7.0	2.45	6.5	2.31
	-9.5	-10	8.4	2.99	8.0	2.85	7.5	2.70	7.2	2.56	7.0	2.43	6.5	2.29
	-8.5	-9.1	8.4	2.91	8.0	2.78	7.5	2.63	7.2	2.50	7.0	2.37	6.5	2.23
	-7	-7.6	8.4	2.80	8.0	2.67	7.5	2.53	7.2	2.40	7.0	2.28	6.5	2.14
	-5	-5.6	8.4	2.65	8.0	2.52	7.5	2.39	7.2	2.27	7.0	2.16	6.5	2.03
	-3	-3.7	8.4	2.49	8.0	2.37	7.5	2.25	7.2	2.14	7.0	2.04	6.5	1.91
	0	-0.7	8.4	2.27	8.0	2.15	7.5	2.04	7.2	1.95	7.0	1.86	6.5	1.74
	3	2.2	8.4	2.04	8.0	1.92	7.5	1.83	7.2	1.75	7.0	1.67	6.5	1.56
	5	4.1	8.4	1.89	8.0	1.78	7.5	1.69	7.2	1.62	7.0	1.55	6.5	1.45
	7	6	8.4	1.74	8.0	1.63	7.5	1.55	7.2	1.49	7.0	1.43	6.5	1.33
9	7.9	8.4	1.55	8.0	1.45	7.5	1.38	7.2	1.33	7.0	1.28	6.5	1.19	
11	9.8	8.4	1.45	8.0	1.36	7.5	1.29	7.2	1.24	7.0	1.19	6.5	1.11	
13	11.8	8.4	1.36	8.0	1.27	7.5	1.21	7.2	1.16	7.0	1.12	6.5	1.04	
15	13.7	8.4	1.28	8.0	1.20	7.5	1.14	7.2	1.10	7.0	1.05	6.5	0.98	
50	-19.8	-20	7.0	3.12	6.6	2.95	6.2	2.78	6.0	2.63	5.8	2.49	5.4	2.35
	-18.8	-19	7.0	3.06	6.6	2.88	6.2	2.73	6.0	2.58	5.8	2.44	5.4	2.31
	-16.7	-17	7.0	2.92	6.6	2.76	6.2	2.61	6.0	2.47	5.8	2.34	5.4	2.21
	-13.7	-15	7.0	2.73	6.6	2.57	6.2	2.44	6.0	2.31	5.8	2.19	5.4	2.06
	-11.8	-13	7.0	2.61	6.6	2.46	6.2	2.33	6.0	2.20	5.8	2.09	5.4	1.97
	-9.8	-11	7.0	2.48	6.6	2.34	6.2	2.22	6.0	2.10	5.8	1.99	5.4	1.88
	-9.5	-10	7.0	2.46	6.6	2.32	6.2	2.20	6.0	2.08	5.8	1.98	5.4	1.87
	-8.5	-9.1	7.0	2.40	6.6	2.26	6.2	2.14	6.0	2.03	5.8	1.93	5.4	1.82
	-7	-7.6	7.0	2.30	6.6	2.17	6.2	2.06	6.0	1.95	5.8	1.86	5.4	1.75
	-5	-5.6	7.0	2.17	6.6	2.04	6.2	1.94	6.0	1.84	5.8	1.76	5.4	1.65
	-3	-3.7	7.0	2.04	6.6	1.92	6.2	1.83	6.0	1.73	5.8	1.66	5.4	1.56
	0	-0.7	7.0	1.85	6.6	1.74	6.2	1.66	6.0	1.57	5.8	1.51	5.4	1.42
	3	2.2	7.0	1.66	6.6	1.56	6.2	1.49	6.0	1.41	5.8	1.36	5.4	1.27
	5	4.1	7.0	1.53	6.6	1.43	6.2	1.38	6.0	1.31	5.8	1.26	5.4	1.18
	7	6	7.0	1.40	6.6	1.31	6.2	1.26	6.0	1.20	5.8	1.16	5.4	1.09
9	7.9	7.0	1.27	6.6	1.18	6.2	1.14	6.0	1.08	5.8	1.05	5.4	0.98	
11	9.8	7.0	1.18	6.6	1.11	6.2	1.07	6.0	1.01	5.8	0.98	5.4	0.92	
13	11.8	7.0	1.11	6.6	1.04	6.2	1.00	6.0	0.95	5.8	0.92	5.4	0.86	
15	13.7	7.0	1.05	6.6	0.98	6.2	0.95	6.0	0.90	5.8	0.87	5.4	0.81	

Note

1. TC: Total Capacity(kW), PI : Power Input(kW, Comp. + Outdoor fan motor)
2. Capacity tables show the average value of conditions which may occur.

6. Capacity Tables

◆ ARUN050LSS0

Combination (%)	Outdoor air temp		Indoor air temp. °C DB											
			16		18		20		21		22		24	
	°C DB	°C WB	TC	PI	TC	PI	TC	PI	TC	PI	TC	PI	TC	PI
130	-19.8	-20	12.7	6.56	12.7	6.60	12.7	6.64	12.7	6.70	12.7	6.75	12.4	6.84
	-18.8	-19	13.0	6.59	13.0	6.63	13.0	6.67	13.0	6.73	13.0	6.78	12.7	6.87
	-16.7	-17	13.7	6.65	13.7	6.69	13.6	6.73	13.6	6.79	13.6	6.84	13.3	6.93
	-13.7	-15	14.6	6.74	14.6	6.78	14.5	6.82	14.5	6.87	14.5	6.93	14.2	6.62
	-11.8	-13	15.0	6.79	15.0	6.83	15.0	6.87	15.0	6.93	15.0	6.71	14.7	6.42
	-9.8	-11	15.5	6.85	15.5	6.89	15.4	6.93	15.4	6.70	15.4	6.49	15.3	6.21
	-9.5	-10	15.6	6.86	15.6	6.90	15.5	6.89	15.5	6.66	15.5	6.46	15.4	6.18
	-8.5	-9.1	15.9	6.88	15.9	6.93	15.8	6.77	15.8	6.54	15.8	6.34	15.7	6.08
	-7	-7.6	16.4	6.93	16.4	6.74	16.3	6.59	16.3	6.37	16.3	6.18	16.1	5.92
	-5	-5.6	17.0	6.68	17.0	6.50	16.9	6.35	16.9	6.14	16.9	5.95	16.7	5.71
	-3	-3.7	17.6	6.44	17.6	6.26	17.4	6.10	17.4	5.91	17.4	5.73	17.3	5.51
	0	-0.7	18.4	6.07	18.4	5.89	18.3	5.74	18.3	5.56	18.3	5.39	18.1	5.19
	3	2.2	19.3	5.70	19.3	5.52	19.2	5.38	19.2	5.21	19.2	5.06	18.1	4.88
	5	4.1	19.9	5.45	19.9	5.28	19.8	5.13	19.8	4.98	19.4	4.83	18.1	4.68
	7	6	20.5	5.20	20.5	5.04	20.4	4.89	20.1	4.75	19.4	4.61	18.1	4.47
	9	7.9	20.7	5.00	20.7	4.84	20.6	4.69	20.1	4.56	19.4	4.42	18.1	4.29
11	9.8	20.7	4.83	20.7	4.67	20.6	4.54	20.1	4.41	19.4	4.27	18.1	4.15	
13	11.8	20.7	4.65	20.7	4.50	20.6	4.37	20.1	4.24	19.4	4.12	18.1	3.99	
15	13.7	20.7	4.46	20.7	4.32	20.6	4.20	20.1	4.07	19.4	3.95	18.1	3.83	
120	-19.8	-20	12.6	6.60	12.6	6.64	12.6	6.70	12.6	6.75	12.6	6.84	12.3	6.90
	-18.8	-19	12.9	6.63	12.9	6.67	12.9	6.73	12.9	6.78	12.9	6.87	12.6	6.93
	-16.7	-17	13.6	6.69	13.6	6.73	13.5	6.79	13.5	6.84	13.5	6.93	13.2	6.73
	-13.7	-15	14.5	6.78	14.5	6.82	14.4	6.87	14.4	6.93	14.4	6.63	14.1	6.44
	-11.8	-13	14.9	6.83	14.9	6.87	14.8	6.93	14.8	6.71	14.8	6.44	14.6	6.26
	-9.8	-11	15.4	6.89	15.4	6.93	15.3	6.69	15.3	6.49	15.3	6.23	15.2	6.07
	-9.5	-10	15.5	6.90	15.5	6.89	15.4	6.65	15.4	6.45	15.4	6.20	15.3	6.04
	-8.5	-9.1	15.8	6.93	15.8	6.76	15.7	6.53	15.7	6.34	15.7	6.10	15.6	5.95
	-7	-7.6	16.3	6.73	16.3	6.57	16.2	6.35	16.2	6.17	16.2	5.95	16.0	5.80
	-5	-5.6	16.8	6.47	16.8	6.31	16.7	6.11	16.7	5.95	16.7	5.75	16.6	5.61
	-3	-3.7	17.4	6.21	17.4	6.06	17.3	5.88	17.3	5.72	17.3	5.55	17.0	5.42
	0	-0.7	18.3	5.82	18.3	5.67	18.2	5.52	18.2	5.38	18.2	5.25	17.0	5.13
	3	2.2	19.2	5.43	19.2	5.29	19.1	5.16	18.8	5.04	18.3	4.95	17.0	4.85
	5	4.1	19.8	5.17	19.8	5.03	19.5	4.92	18.8	4.82	18.3	4.75	17.0	4.66
	7	6	20.4	4.91	20.3	4.78	19.5	4.68	18.8	4.59	18.3	4.55	17.0	4.47
	9	7.9	20.5	4.70	20.3	4.58	19.5	4.49	18.8	4.40	18.3	4.36	17.0	4.28
11	9.8	20.5	4.54	20.3	4.42	19.5	4.33	18.8	4.25	18.3	4.21	17.0	4.13	
13	11.8	20.5	4.37	20.3	4.25	19.5	4.16	18.8	4.08	18.3	4.04	17.0	3.97	
15	13.7	20.5	4.18	20.3	4.07	19.5	3.99	18.8	3.91	18.3	3.87	17.0	3.80	
110	-19.8	-20	12.6	6.64	12.6	6.70	12.5	6.75	12.5	6.84	12.5	6.90	12.2	6.93
	-18.8	-19	12.9	6.67	12.9	6.73	12.8	6.78	12.8	6.87	12.8	6.93	12.5	6.82
	-16.7	-17	13.5	6.73	13.5	6.79	13.4	6.84	13.4	6.93	13.4	6.71	13.1	6.61
	-13.7	-15	14.4	6.82	14.4	6.87	14.3	6.93	14.3	6.60	14.3	6.41	14.3	6.30
	-11.8	-13	14.9	6.87	14.9	6.93	14.8	6.70	14.8	6.40	14.8	6.22	14.8	6.11
	-9.8	-11	15.3	6.93	15.3	6.67	15.3	6.45	15.3	6.18	15.3	6.01	15.2	5.90
	-9.5	-10	15.4	6.88	15.4	6.63	15.3	6.42	15.3	6.15	15.3	5.98	15.3	5.87
	-8.5	-9.1	15.7	6.74	15.7	6.50	15.6	6.30	15.6	6.04	15.6	5.88	15.3	5.77
	-7	-7.6	16.2	6.53	16.2	6.30	16.1	6.12	16.1	5.88	16.1	5.73	15.3	5.61
	-5	-5.6	16.8	6.24	16.8	6.04	16.6	5.87	16.6	5.66	16.4	5.53	15.3	5.41
	-3	-3.7	17.3	5.96	17.3	5.78	17.2	5.63	16.9	5.45	16.4	5.32	15.3	5.20
	0	-0.7	18.2	5.53	18.2	5.38	17.5	5.27	16.9	5.12	16.4	5.02	15.3	4.89
	3	2.2	19.1	5.11	18.6	4.99	17.5	4.90	16.9	4.80	16.4	4.71	15.3	4.59
	5	4.1	19.7	4.82	18.6	4.73	17.5	4.66	16.9	4.58	16.4	4.51	15.3	4.38
	7	6	19.7	4.54	18.6	4.47	17.5	4.42	16.9	4.36	16.4	4.31	15.3	4.18
	9	7.9	19.7	4.33	18.6	4.27	17.5	4.22	16.9	4.17	16.4	4.11	15.3	3.99
11	9.8	19.7	4.16	18.6	4.10	17.5	4.05	16.9	4.00	16.4	3.95	15.3	3.83	
13	11.8	19.7	3.98	18.6	3.92	17.5	3.88	16.9	3.83	16.4	3.78	15.3	3.66	
15	13.7	19.7	3.79	18.6	3.73	17.5	3.69	16.9	3.65	16.4	3.60	15.3	3.49	

6. Capacity Tables

Combination (%)	Outdoor air temp		Indoor air temp. °C DB											
			16		18		20		21		22		24	
	°C DB	°C WB	TC	PI	TC	PI	TC	PI	TC	PI	TC	PI	TC	PI
100	-19.8	-20	12.5	7.11	12.5	7.07	12.4	6.99	12.4	6.98	12.4	6.98	12.2	6.93
	-18.8	-19	12.8	7.09	12.7	7.05	12.7	7.02	12.7	6.97	12.7	6.93	12.5	6.81
	-16.7	-17	13.4	7.05	13.4	7.02	13.4	7.08	13.3	6.93	13.3	6.67	13.0	6.55
	-13.7	-15	14.3	7.00	14.3	6.96	14.2	6.93	14.2	6.56	14.2	6.31	14.0	6.19
	-11.8	-13	14.8	6.96	14.7	6.93	14.7	6.68	14.7	6.32	14.7	6.09	14.0	5.96
	-9.8	-11	15.3	6.93	15.3	6.64	15.2	6.41	15.2	6.07	15.0	5.85	14.0	5.72
	-9.5	-10	15.4	6.88	15.4	6.60	15.3	6.37	15.3	6.04	15.0	5.81	14.0	5.68
	-8.5	-9.1	15.6	6.73	15.6	6.46	15.6	6.24	15.5	5.91	15.0	5.69	14.0	5.56
	-7	-7.6	16.4	6.50	16.3	6.24	16.0	6.04	15.5	5.73	15.0	5.51	14.0	5.38
	-5	-5.6	17.1	6.20	16.9	5.96	16.0	5.77	15.5	5.48	15.0	5.27	14.0	5.13
	-3	-3.7	17.6	5.90	17.0	5.68	16.0	5.51	15.5	5.23	15.0	5.03	14.0	4.89
	0	-0.7	18.0	5.45	17.0	5.25	16.0	5.11	15.5	4.86	15.0	4.67	14.0	4.53
	3	2.2	18.0	5.00	17.0	4.82	16.0	4.71	15.5	4.49	15.0	4.31	14.0	4.16
	5	4.1	18.0	4.69	17.0	4.54	16.0	4.45	15.5	4.25	15.0	4.07	14.0	3.92
	7	6	18.0	4.39	17.0	4.25	16.0	4.18	15.5	4.00	15.0	3.83	14.0	3.68
	9	7.9	18.0	4.16	17.0	4.03	16.0	3.96	15.5	3.79	15.0	3.63	14.0	3.49
11	9.8	18.0	3.97	17.0	3.84	16.0	3.78	15.5	3.61	15.0	3.46	14.0	3.33	
13	11.8	18.0	3.76	17.0	3.65	16.0	3.58	15.5	3.43	15.0	3.28	14.0	3.15	
15	13.7	18.0	3.55	17.0	3.44	16.0	3.38	15.5	3.23	15.0	3.09	14.0	2.97	
90	-19.8	-20	12.5	6.54	12.5	6.62	12.4	6.68	12.4	6.71	12.4	6.49	12.1	6.18
	-18.8	-19	12.8	6.57	12.7	6.65	12.7	6.71	12.7	6.60	12.7	6.38	12.4	6.08
	-16.7	-17	13.4	6.63	13.4	6.71	13.3	6.47	13.3	6.36	13.3	6.15	12.8	5.85
	-13.7	-15	14.3	6.71	14.3	6.35	14.2	6.13	14.2	6.02	13.7	5.82	12.8	5.54
	-11.8	-13	14.8	6.46	14.7	6.13	14.6	5.92	14.2	5.80	13.7	5.61	12.8	5.34
	-9.8	-11	15.3	6.20	15.3	5.89	14.6	5.69	14.2	5.57	13.7	5.39	12.8	5.12
	-9.5	-10	15.4	6.16	15.4	5.85	14.6	5.66	14.2	5.54	13.7	5.36	12.8	5.09
	-8.5	-9.1	15.6	6.03	15.5	5.74	14.6	5.54	14.2	5.42	13.7	5.25	12.8	4.99
	-7	-7.6	16.4	5.84	15.6	5.56	14.6	5.37	14.2	5.25	13.7	5.09	12.8	4.83
	-5	-5.6	16.5	5.58	15.6	5.32	14.6	5.15	14.2	5.02	13.7	4.87	12.8	4.62
	-3	-3.7	16.5	5.32	15.6	5.08	14.6	4.92	14.2	4.80	13.7	4.65	12.8	4.40
	0	-0.7	16.5	4.93	15.6	4.72	14.6	4.58	14.2	4.45	13.7	4.32	12.8	4.09
	3	2.2	16.5	4.54	15.6	4.37	14.6	4.24	14.2	4.11	13.7	3.99	12.8	3.77
	5	4.1	16.5	4.27	15.6	4.13	14.6	4.01	14.2	3.88	13.7	3.77	12.8	3.56
	7	6	16.5	4.01	15.6	3.89	14.6	3.79	14.2	3.66	13.7	3.55	12.8	3.35
	9	7.9	16.5	3.77	15.6	3.66	14.6	3.56	14.2	3.44	13.7	3.34	12.8	3.15
11	9.8	16.5	3.53	15.6	3.42	14.6	3.33	14.2	3.22	13.7	3.12	12.8	2.94	
13	11.8	16.5	3.29	15.6	3.19	14.6	3.11	14.2	3.00	13.7	2.91	12.8	2.74	
15	13.7	16.5	3.05	15.6	2.96	14.6	2.88	14.2	2.78	13.7	2.70	12.8	2.54	
80	-19.8	-20	12.3	5.78	12.3	5.86	12.3	5.95	12.3	5.75	12.2	5.49	11.4	5.23
	-18.8	-19	12.6	5.81	12.6	5.95	12.6	5.85	12.6	5.65	12.2	5.39	11.4	5.14
	-16.7	-17	13.1	5.95	13.1	5.74	13.1	5.64	12.7	5.44	12.2	5.20	11.4	4.95
	-13.7	-15	13.1	5.63	13.1	5.43	13.1	5.33	12.7	5.15	12.2	4.92	11.4	4.69
	-11.8	-13	13.4	5.43	13.1	5.24	13.1	5.14	12.7	4.96	12.2	4.74	11.4	4.52
	-9.8	-11	14.0	5.21	13.6	5.03	13.1	4.93	12.7	4.76	12.2	4.55	11.4	4.34
	-9.5	-10	14.1	5.18	13.7	5.00	13.1	4.90	12.7	4.73	12.2	4.52	11.4	4.31
	-8.5	-9.1	14.4	5.08	13.9	4.90	13.1	4.80	12.7	4.63	12.2	4.43	11.4	4.23
	-7	-7.6	14.8	4.91	13.9	4.75	13.1	4.65	12.7	4.48	12.2	4.29	11.4	4.09
	-5	-5.6	14.8	4.70	13.9	4.54	13.1	4.44	12.7	4.28	12.2	4.10	11.4	3.92
	-3	-3.7	14.8	4.49	13.9	4.34	13.1	4.24	12.7	4.08	12.2	3.92	11.4	3.74
	0	-0.7	14.8	4.17	13.9	4.03	13.1	3.93	12.7	3.78	12.2	3.64	11.4	3.47
	3	2.2	14.8	3.85	13.9	3.73	13.1	3.63	12.7	3.49	12.2	3.36	11.4	3.21
	5	4.1	14.8	3.63	13.9	3.52	13.1	3.43	12.7	3.29	12.2	3.17	11.4	3.03
	7	6	14.8	3.42	13.9	3.32	13.1	3.22	12.7	3.09	12.2	2.99	11.4	2.85
	9	7.9	14.8	3.21	13.9	3.12	13.1	3.02	12.7	2.90	12.2	2.80	11.4	2.68
11	9.8	14.8	2.98	13.9	2.89	13.1	2.81	12.7	2.69	12.2	2.60	11.4	2.48	
13	11.8	14.8	2.78	13.9	2.70	13.1	2.62	12.7	2.51	12.2	2.43	11.4	2.32	
15	13.7	14.8	2.62	13.9	2.54	13.1	2.47	12.7	2.36	12.2	2.29	11.4	2.18	

6. Capacity Tables

Combination (%)	Outdoor air temp		Indoor air temp. °C DB											
			16		18		20		21		22		24	
	°C DB	°C WB	TC	PI	TC	PI	TC	PI	TC	PI	TC	PI	TC	PI
70	-19.8	-20	12.2	5.78	11.8	5.81	11.1	5.60	10.8	5.31	10.4	5.05	9.7	4.79
	-18.8	-19	12.5	5.81	11.8	5.70	11.1	5.49	10.8	5.21	10.4	4.95	9.7	4.70
	-16.7	-17	12.5	5.58	11.8	5.47	11.1	5.27	10.8	5.00	10.4	4.76	9.7	4.51
	-13.7	-15	12.5	5.25	11.8	5.14	11.1	4.95	10.8	4.70	10.4	4.48	9.7	4.25
	-11.8	-13	12.5	5.04	11.8	4.93	11.1	4.75	10.8	4.51	10.4	4.30	9.7	4.08
	-9.8	-11	12.5	4.82	11.8	4.71	11.1	4.54	10.8	4.31	10.4	4.12	9.7	3.90
	-9.5	-10	12.5	4.79	11.8	4.68	11.1	4.51	10.8	4.28	10.4	4.09	9.7	3.87
	-8.5	-9.1	12.5	4.68	11.8	4.57	11.1	4.40	10.8	4.18	10.4	4.00	9.7	3.78
	-7	-7.6	12.5	4.52	11.8	4.40	11.1	4.24	10.8	4.03	10.4	3.86	9.7	3.65
	-5	-5.6	12.5	4.30	11.8	4.18	11.1	4.03	10.8	3.83	10.4	3.67	9.7	3.47
	-3	-3.7	12.5	4.08	11.8	3.96	11.1	3.82	10.8	3.64	10.4	3.49	9.7	3.29
	0	-0.7	12.5	3.75	11.8	3.63	11.1	3.50	10.8	3.34	10.4	3.21	9.7	3.03
	3	2.2	12.5	3.42	11.8	3.30	11.1	3.19	10.8	3.04	10.4	2.93	9.7	2.76
	5	4.1	12.5	3.20	11.8	3.08	11.1	2.97	10.8	2.84	10.4	2.74	9.7	2.58
	7	6	12.5	2.98	11.8	2.86	11.1	2.76	10.8	2.64	10.4	2.56	9.7	2.40
	9	7.9	12.5	2.69	11.8	2.58	11.1	2.49	10.8	2.38	10.4	2.31	9.7	2.17
11	9.8	12.5	2.50	11.8	2.40	11.1	2.32	10.8	2.22	10.4	2.15	9.7	2.02	
13	11.8	12.5	2.34	11.8	2.25	11.1	2.17	10.8	2.07	10.4	2.01	9.7	1.89	
15	13.7	12.5	2.21	11.8	2.12	11.1	2.05	10.8	1.96	10.4	1.90	9.7	1.78	
60	-19.8	-20	10.8	5.73	10.2	5.50	9.6	5.20	9.2	4.91	8.9	4.65	8.3	4.39
	-18.8	-19	10.8	5.61	10.2	5.39	9.6	5.09	9.2	4.82	8.9	4.56	8.3	4.30
	-16.7	-17	10.8	5.37	10.2	5.15	9.6	4.87	9.2	4.61	8.9	4.36	8.3	4.12
	-13.7	-15	10.8	5.02	10.2	4.81	9.6	4.55	9.2	4.31	8.9	4.09	8.3	3.85
	-11.8	-13	10.8	4.81	10.2	4.60	9.6	4.35	9.2	4.12	8.9	3.91	8.3	3.68
	-9.8	-11	10.8	4.58	10.2	4.37	9.6	4.14	9.2	3.93	8.9	3.73	8.3	3.51
	-9.5	-10	10.8	4.54	10.2	4.34	9.6	4.11	9.2	3.90	8.9	3.70	8.3	3.48
	-8.5	-9.1	10.8	4.43	10.2	4.22	9.6	4.00	9.2	3.80	8.9	3.61	8.3	3.39
	-7	-7.6	10.8	4.25	10.2	4.05	9.6	3.84	9.2	3.65	8.9	3.47	8.3	3.26
	-5	-5.6	10.8	4.02	10.2	3.83	9.6	3.63	9.2	3.45	8.9	3.28	8.3	3.08
	-3	-3.7	10.8	3.79	10.2	3.60	9.6	3.42	9.2	3.25	8.9	3.10	8.3	2.91
	0	-0.7	10.8	3.45	10.2	3.26	9.6	3.10	9.2	2.96	8.9	2.82	8.3	2.64
	3	2.2	10.8	3.10	10.2	2.93	9.6	2.78	9.2	2.66	8.9	2.54	8.3	2.38
	5	4.1	10.8	2.87	10.2	2.70	9.6	2.57	9.2	2.46	8.9	2.36	8.3	2.20
	7	6	10.8	2.64	10.2	2.47	9.6	2.36	9.2	2.27	8.9	2.17	8.3	2.02
	9	7.9	10.8	2.36	10.2	2.21	9.6	2.10	9.2	2.02	8.9	1.94	8.3	1.80
11	9.8	10.8	2.20	10.2	2.06	9.6	1.96	9.2	1.89	8.9	1.81	8.3	1.68	
13	11.8	10.8	2.06	10.2	1.93	9.6	1.84	9.2	1.77	8.9	1.70	8.3	1.58	
15	13.7	10.8	1.95	10.2	1.82	9.6	1.74	9.2	1.67	8.9	1.60	8.3	1.49	
50	-19.8	-20	9.0	4.75	8.5	4.48	8.0	4.23	7.7	4.00	7.5	3.78	6.9	3.58
	-18.8	-19	9.0	4.65	8.5	4.38	8.0	4.15	7.7	3.92	7.5	3.71	6.9	3.50
	-16.7	-17	9.0	4.44	8.5	4.19	8.0	3.96	7.7	3.75	7.5	3.55	6.9	3.35
	-13.7	-15	9.0	4.15	8.5	3.91	8.0	3.71	7.7	3.50	7.5	3.33	6.9	3.14
	-11.8	-13	9.0	3.96	8.5	3.74	8.0	3.54	7.7	3.35	7.5	3.18	6.9	3.00
	-9.8	-11	9.0	3.77	8.5	3.55	8.0	3.37	7.7	3.19	7.5	3.03	6.9	2.86
	-9.5	-10	9.0	3.74	8.5	3.52	8.0	3.34	7.7	3.16	7.5	3.01	6.9	2.84
	-8.5	-9.1	9.0	3.64	8.5	3.43	8.0	3.26	7.7	3.08	7.5	2.93	6.9	2.76
	-7	-7.6	9.0	3.50	8.5	3.29	8.0	3.13	7.7	2.96	7.5	2.82	6.9	2.66
	-5	-5.6	9.0	3.30	8.5	3.11	8.0	2.96	7.7	2.80	7.5	2.67	6.9	2.51
	-3	-3.7	9.0	3.11	8.5	2.92	8.0	2.78	7.7	2.64	7.5	2.52	6.9	2.37
	0	-0.7	9.0	2.81	8.5	2.64	8.0	2.52	7.7	2.39	7.5	2.30	6.9	2.15
	3	2.2	9.0	2.52	8.5	2.37	8.0	2.27	7.7	2.15	7.5	2.07	6.9	1.94
	5	4.1	9.0	2.33	8.5	2.18	8.0	2.09	7.7	1.99	7.5	1.92	6.9	1.79
	7	6	9.0	2.13	8.5	1.99	8.0	1.92	7.7	1.82	7.5	1.77	6.9	1.65
	9	7.9	9.0	1.92	8.5	1.80	8.0	1.73	7.7	1.65	7.5	1.60	6.9	1.49
11	9.8	9.0	1.80	8.5	1.69	8.0	1.62	7.7	1.54	7.5	1.49	6.9	1.39	
13	11.8	9.0	1.69	8.5	1.58	8.0	1.52	7.7	1.45	7.5	1.40	6.9	1.31	
15	13.7	9.0	1.60	8.5	1.50	8.0	1.44	7.7	1.37	7.5	1.33	6.9	1.24	

Note

1. TC: Total Capacity(kW), PI : Power Input(kW, Comp. + Outdoor fan motor)
2. Capacity tables show the average value of conditions which may occur.

6. Capacity Tables

◆ ARUN060LSS0

Combination (%)	Outdoor air temp		Indoor air temp. °C DB											
			16		18		20		21		22		24	
	°C DB	°C WB	TC	PI	TC	PI	TC	PI	TC	PI	TC	PI	TC	PI
130	-19.8	-20	14.3	7.85	14.3	7.90	14.2	7.95	14.2	8.01	14.2	8.08	14.0	8.18
	-18.8	-19	14.7	7.88	14.7	7.93	14.6	7.98	14.6	8.05	14.6	8.11	14.3	8.21
	-16.7	-17	15.4	7.96	15.4	8.01	15.3	8.05	15.3	8.12	15.3	8.18	15.0	8.29
	-13.7	-15	16.4	8.06	16.4	8.11	16.3	8.15	16.3	8.22	16.3	8.29	16.0	7.91
	-11.8	-13	16.9	8.12	16.9	8.17	16.8	8.22	16.8	8.29	16.8	8.03	16.6	7.68
	-9.8	-11	17.5	8.19	17.5	8.24	17.4	8.29	17.4	8.01	17.4	7.76	17.2	7.43
	-9.5	-10	17.6	8.20	17.6	8.25	17.5	8.24	17.5	7.97	17.5	7.72	17.3	7.39
	-8.5	-9.1	17.9	8.23	17.9	8.29	17.8	8.10	17.8	7.83	17.7	7.59	17.7	7.27
	-7	-7.6	18.4	8.29	18.4	8.07	18.3	7.88	18.3	7.62	18.3	7.39	18.2	7.08
	-5	-5.6	19.1	7.99	19.1	7.78	19.0	7.59	19.0	7.34	19.0	7.12	18.8	6.83
	-3	-3.7	19.7	7.70	19.7	7.48	19.6	7.30	19.6	7.07	19.6	6.85	19.5	6.59
	0	-0.7	20.7	7.26	20.7	7.05	20.6	6.87	20.6	6.65	20.6	6.45	20.3	6.21
	3	2.2	21.7	6.81	21.7	6.61	21.6	6.43	21.6	6.23	21.6	6.05	20.3	5.84
	5	4.1	22.4	6.52	22.4	6.32	22.3	6.14	22.3	5.96	21.8	5.78	20.3	5.59
	7	6	23.1	6.23	23.1	6.03	22.9	5.85	22.6	5.68	21.8	5.51	20.3	5.35
	9	7.9	23.3	5.98	23.3	5.78	23.2	5.62	22.6	5.45	21.8	5.29	20.3	5.13
11	9.8	23.3	5.78	23.3	5.59	23.2	5.43	22.6	5.27	21.8	5.11	20.3	4.96	
13	11.8	23.3	5.56	23.3	5.39	23.2	5.23	22.6	5.08	21.8	4.93	20.3	4.78	
15	13.7	23.3	5.34	23.3	5.17	23.2	5.02	22.6	4.87	21.8	4.73	20.3	4.59	
120	-19.8	-20	14.2	7.90	14.2	7.95	14.1	8.01	14.1	8.08	14.1	8.18	13.9	8.25
	-18.8	-19	14.6	7.93	14.6	7.98	14.5	8.05	14.5	8.11	14.5	8.21	14.2	8.29
	-16.7	-17	15.3	8.01	15.3	8.05	15.2	8.12	15.2	8.18	15.2	8.29	14.9	8.05
	-13.7	-15	16.3	8.11	16.3	8.15	16.2	8.22	16.2	8.29	16.2	7.93	15.8	7.70
	-11.8	-13	16.8	8.17	16.8	8.22	16.7	8.29	16.7	8.03	16.7	7.70	16.5	7.49
	-9.8	-11	17.4	8.24	17.4	8.29	17.3	8.00	17.3	7.76	17.3	7.46	17.1	7.26
	-9.5	-10	17.5	8.25	17.5	8.24	17.4	7.96	17.4	7.72	17.4	7.42	17.2	7.23
	-8.5	-9.1	17.8	8.29	17.8	8.09	17.7	7.81	17.7	7.58	17.7	7.30	17.5	7.11
	-7	-7.6	18.3	8.05	18.3	7.86	18.2	7.60	18.2	7.38	18.2	7.12	18.0	6.94
	-5	-5.6	18.9	7.74	18.9	7.55	18.8	7.31	18.8	7.11	18.8	6.88	18.7	6.71
	-3	-3.7	19.6	7.43	19.6	7.24	19.5	7.03	19.5	6.84	19.5	6.64	19.1	6.48
	0	-0.7	20.6	6.96	20.6	6.78	20.5	6.60	20.5	6.44	20.5	6.28	19.1	6.14
	3	2.2	21.6	6.49	21.6	6.33	21.5	6.17	21.2	6.03	20.5	5.92	19.1	5.80
	5	4.1	22.2	6.18	22.2	6.02	21.9	5.89	21.2	5.76	20.5	5.68	19.1	5.57
	7	6	22.9	5.87	22.8	5.71	21.9	5.60	21.2	5.49	20.5	5.44	19.1	5.34
	9	7.9	23.1	5.63	22.8	5.48	21.9	5.37	21.2	5.26	20.5	5.21	19.1	5.12
11	9.8	23.1	5.43	22.8	5.28	21.9	5.18	21.2	5.08	20.5	5.03	19.1	4.94	
13	11.8	23.1	5.22	22.8	5.08	21.9	4.98	21.2	4.88	20.5	4.84	19.1	4.75	
15	13.7	23.1	5.00	22.8	4.86	21.9	4.77	21.2	4.68	20.5	4.63	19.1	4.55	
110	-19.8	-20	14.2	7.95	14.2	8.01	14.1	8.08	14.1	8.18	14.1	8.25	13.8	8.29
	-18.8	-19	14.5	7.98	14.5	8.05	14.4	8.11	14.4	8.21	14.4	8.29	14.1	8.16
	-16.7	-17	15.2	8.05	15.2	8.12	15.1	8.18	15.1	8.29	15.1	8.03	14.8	7.91
	-13.7	-15	16.2	8.15	16.2	8.22	16.1	8.29	16.1	7.90	16.1	7.67	16.1	7.54
	-11.8	-13	16.7	8.22	16.7	8.29	16.6	8.01	16.6	7.65	16.6	7.44	16.6	7.30
	-9.8	-11	17.3	8.29	17.3	7.97	17.2	7.72	17.2	7.39	17.2	7.19	17.1	7.06
	-9.5	-10	17.4	8.24	17.4	7.93	17.3	7.68	17.3	7.35	17.3	7.16	17.2	7.02
	-8.5	-9.1	17.7	8.06	17.7	7.77	17.6	7.53	17.6	7.23	17.6	7.04	17.2	6.90
	-7	-7.6	18.2	7.81	18.2	7.54	18.1	7.31	18.1	7.03	18.1	6.85	17.2	6.71
	-5	-5.6	18.8	7.47	18.8	7.22	18.7	7.02	18.7	6.77	18.4	6.61	17.2	6.47
	-3	-3.7	19.5	7.13	19.5	6.91	19.4	6.73	19.0	6.51	18.4	6.37	17.2	6.22
	0	-0.7	20.5	6.62	20.5	6.44	19.7	6.30	19.0	6.13	18.4	6.00	17.2	5.85
	3	2.2	21.5	6.11	21.0	5.97	19.7	5.86	19.0	5.74	18.4	5.64	17.2	5.49
	5	4.1	22.1	5.77	21.0	5.66	19.7	5.57	19.0	5.48	18.4	5.40	17.2	5.24
	7	6	22.2	5.43	21.0	5.35	19.7	5.29	19.0	5.22	18.4	5.15	17.2	4.99
	9	7.9	22.2	5.18	21.0	5.10	19.7	5.04	19.0	4.98	18.4	4.92	17.2	4.77
11	9.8	22.2	4.98	21.0	4.90	19.7	4.85	19.0	4.79	18.4	4.73	17.2	4.58	
13	11.8	22.2	4.76	21.0	4.69	19.7	4.64	19.0	4.58	18.4	4.52	17.2	4.38	
15	13.7	22.2	4.53	21.0	4.46	19.7	4.41	19.0	4.36	18.4	4.30	17.2	4.17	

6. Capacity Tables

Combination (%)	Outdoor air temp		Indoor air temp. °C DB											
			16		18		20		21		22		24	
	°C DB	°C WB	TC	PI	TC	PI	TC	PI	TC	PI	TC	PI	TC	PI
100	-19.8	-20	14.1	8.50	14.1	8.46	14.0	8.36	14.0	8.35	14.0	8.35	13.7	8.29
	-18.8	-19	14.4	8.48	14.3	8.44	14.3	8.40	14.3	8.33	14.3	8.29	14.0	8.14
	-16.7	-17	15.0	8.44	15.0	8.39	15.0	8.47	14.9	8.29	14.9	7.98	14.6	7.84
	-13.7	-15	16.1	8.37	16.1	8.33	16.0	8.29	16.0	7.84	16.0	7.55	15.7	7.40
	-11.8	-13	16.6	8.33	16.5	8.29	16.5	7.98	16.5	7.56	16.5	7.28	15.7	7.13
	-9.8	-11	17.2	8.29	17.2	7.95	17.1	7.67	17.1	7.27	16.8	6.99	15.7	6.84
	-9.5	-10	17.3	8.23	17.3	7.89	17.2	7.62	17.2	7.22	16.8	6.95	15.7	6.79
	-8.5	-9.1	17.6	8.05	17.6	7.72	17.5	7.46	17.4	7.07	16.8	6.81	15.7	6.65
	-7	-7.6	18.4	7.78	18.3	7.47	18.0	7.22	17.4	6.85	16.8	6.59	15.7	6.43
	-5	-5.6	19.2	7.42	19.0	7.13	18.0	6.90	17.4	6.56	16.8	6.30	15.7	6.14
	-3	-3.7	19.8	7.06	19.2	6.79	18.0	6.59	17.4	6.26	16.8	6.01	15.7	5.85
	0	-0.7	20.3	6.52	19.2	6.28	18.0	6.11	17.4	5.82	16.8	5.58	15.7	5.42
	3	2.2	20.3	5.98	19.2	5.77	18.0	5.63	17.4	5.37	16.8	5.15	15.7	4.98
	5	4.1	20.3	5.61	19.2	5.43	18.0	5.32	17.4	5.08	16.8	4.86	15.7	4.69
	7	6	20.3	5.25	19.2	5.09	18.0	5.00	17.4	4.78	16.8	4.58	15.7	4.40
	9	7.9	20.3	4.98	19.2	4.82	18.0	4.74	17.4	4.54	16.8	4.34	15.7	4.17
11	9.8	20.3	4.75	19.2	4.60	18.0	4.52	17.4	4.32	16.8	4.14	15.7	3.98	
13	11.8	20.3	4.50	19.2	4.36	18.0	4.29	17.4	4.10	16.8	3.92	15.7	3.77	
15	13.7	20.3	4.24	19.2	4.11	18.0	4.04	17.4	3.86	16.8	3.70	15.7	3.56	
90	-19.8	-20	14.0	7.82	14.0	7.92	13.9	7.99	13.9	8.03	13.9	7.77	13.7	7.40
	-18.8	-19	14.4	7.85	14.3	7.96	14.3	8.03	14.3	7.89	14.3	7.63	14.0	7.27
	-16.7	-17	15.0	7.93	15.0	8.03	15.0	7.74	15.0	7.61	15.0	7.36	14.3	7.00
	-13.7	-15	16.1	8.03	16.1	7.60	16.0	7.34	16.0	7.20	15.4	6.96	14.3	6.62
	-11.8	-13	16.6	7.73	16.5	7.33	16.5	7.08	16.0	6.94	15.4	6.71	14.3	6.38
	-9.8	-11	17.2	7.42	17.2	7.05	16.5	6.81	16.0	6.66	15.4	6.45	14.3	6.13
	-9.5	-10	17.3	7.37	17.3	7.00	16.5	6.77	16.0	6.62	15.4	6.41	14.3	6.09
	-8.5	-9.1	17.6	7.22	17.5	6.86	16.5	6.63	16.0	6.49	15.4	6.28	14.3	5.96
	-7	-7.6	18.4	6.98	17.5	6.65	16.5	6.43	16.0	6.28	15.4	6.08	14.3	5.77
	-5	-5.6	18.6	6.67	17.5	6.36	16.5	6.16	16.0	6.01	15.4	5.82	14.3	5.52
	-3	-3.7	18.6	6.36	17.5	6.08	16.5	5.88	16.0	5.74	15.4	5.56	14.3	5.27
	0	-0.7	18.6	5.89	17.5	5.65	16.5	5.48	16.0	5.33	15.4	5.16	14.3	4.89
	3	2.2	18.6	5.42	17.5	5.22	16.5	5.07	16.0	4.92	15.4	4.77	14.3	4.51
	5	4.1	18.6	5.11	17.5	4.94	16.5	4.80	16.0	4.65	15.4	4.51	14.3	4.26
	7	6	18.6	4.80	17.5	4.65	16.5	4.53	16.0	4.37	15.4	4.24	14.3	4.00
	9	7.9	18.6	4.51	17.5	4.37	16.5	4.26	16.0	4.11	15.4	3.99	14.3	3.76
11	9.8	18.6	4.23	17.5	4.10	16.5	3.99	16.0	3.85	15.4	3.74	14.3	3.52	
13	11.8	18.6	3.94	17.5	3.82	16.5	3.71	16.0	3.59	15.4	3.48	14.3	3.28	
15	13.7	18.6	3.65	17.5	3.54	16.5	3.44	16.0	3.33	15.4	3.23	14.3	3.04	
80	-19.8	-20	13.9	6.91	13.9	7.01	13.9	7.12	13.9	6.88	13.8	6.56	12.8	6.25
	-18.8	-19	14.2	6.95	14.2	7.12	14.2	7.00	14.2	6.76	13.8	6.45	12.8	6.15
	-16.7	-17	14.7	7.12	14.7	6.86	14.7	6.74	14.3	6.51	13.8	6.22	12.8	5.92
	-13.7	-15	14.7	6.74	14.7	6.50	14.7	6.38	14.3	6.16	13.8	5.88	12.8	5.61
	-11.8	-13	15.1	6.49	14.7	6.26	14.7	6.14	14.3	5.93	13.8	5.67	12.8	5.40
	-9.8	-11	15.7	6.24	15.3	6.02	14.7	5.90	14.3	5.69	13.8	5.45	12.8	5.19
	-9.5	-10	15.8	6.20	15.4	5.98	14.7	5.86	14.3	5.66	13.8	5.41	12.8	5.16
	-8.5	-9.1	16.2	6.07	15.7	5.86	14.7	5.74	14.3	5.54	13.8	5.30	12.8	5.05
	-7	-7.6	16.6	5.88	15.7	5.68	14.7	5.56	14.3	5.36	13.8	5.13	12.8	4.90
	-5	-5.6	16.6	5.62	15.7	5.43	14.7	5.32	14.3	5.12	13.8	4.91	12.8	4.68
	-3	-3.7	16.6	5.37	15.7	5.19	14.7	5.07	14.3	4.88	13.8	4.69	12.8	4.47
	0	-0.7	16.6	4.98	15.7	4.82	14.7	4.71	14.3	4.53	13.8	4.35	12.8	4.15
	3	2.2	16.6	4.60	15.7	4.46	14.7	4.34	14.3	4.17	13.8	4.02	12.8	3.83
	5	4.1	16.6	4.34	15.7	4.21	14.7	4.10	14.3	3.93	13.8	3.79	12.8	3.62
	7	6	16.6	4.09	15.7	3.97	14.7	3.85	14.3	3.69	13.8	3.57	12.8	3.41
	9	7.9	16.6	3.84	15.7	3.73	14.7	3.62	14.3	3.47	13.8	3.35	12.8	3.20
11	9.8	16.6	3.56	15.7	3.46	14.7	3.36	14.3	3.22	13.8	3.11	12.8	2.97	
13	11.8	16.6	3.33	15.7	3.23	14.7	3.13	14.3	3.00	13.8	2.91	12.8	2.77	
15	13.7	16.6	3.13	15.7	3.04	14.7	2.95	14.3	2.83	13.8	2.74	12.8	2.61	

6. Capacity Tables

Combination (%)	Outdoor air temp		Indoor air temp. °C DB											
			16		18		20		21		22		24	
	°C DB	°C WB	TC	PI	TC	PI	TC	PI	TC	PI	TC	PI	TC	PI
70	-19.8	-20	13.8	6.92	13.3	6.95	12.5	6.70	12.1	6.36	11.8	6.04	11.0	5.73
	-18.8	-19	14.1	6.95	13.3	6.82	12.5	6.57	12.1	6.24	11.8	5.93	11.0	5.62
	-16.7	-17	14.1	6.68	13.3	6.54	12.5	6.31	12.1	5.98	11.8	5.69	11.0	5.40
	-13.7	-15	14.1	6.28	13.3	6.15	12.5	5.93	12.1	5.63	11.8	5.36	11.0	5.08
	-11.8	-13	14.1	6.03	13.3	5.90	12.5	5.69	12.1	5.40	11.8	5.15	11.0	4.88
	-9.8	-11	14.1	5.77	13.3	5.63	12.5	5.43	12.1	5.16	11.8	4.93	11.0	4.66
	-9.5	-10	14.1	5.73	13.3	5.59	12.5	5.39	12.1	5.12	11.8	4.89	11.0	4.63
	-8.5	-9.1	14.1	5.60	13.3	5.46	12.5	5.27	12.1	5.01	11.8	4.78	11.0	4.53
	-7	-7.6	14.1	5.40	13.3	5.26	12.5	5.08	12.1	4.83	11.8	4.62	11.0	4.37
	-5	-5.6	14.1	5.14	13.3	5.00	12.5	4.82	12.1	4.59	11.8	4.39	11.0	4.15
	-3	-3.7	14.1	4.88	13.3	4.74	12.5	4.57	12.1	4.35	11.8	4.17	11.0	3.94
	0	-0.7	14.1	4.48	13.3	4.34	12.5	4.19	12.1	3.99	11.8	3.84	11.0	3.62
	3	2.2	14.1	4.09	13.3	3.95	12.5	3.81	12.1	3.63	11.8	3.50	11.0	3.30
	5	4.1	14.1	3.82	13.3	3.68	12.5	3.56	12.1	3.39	11.8	3.28	11.0	3.09
	7	6	14.1	3.56	13.3	3.42	12.5	3.30	12.1	3.15	11.8	3.06	11.0	2.88
9	7.9	14.1	3.22	13.3	3.09	12.5	2.98	12.1	2.85	11.8	2.76	11.0	2.60	
11	9.8	14.1	2.99	13.3	2.87	12.5	2.78	12.1	2.65	11.8	2.57	11.0	2.42	
13	11.8	14.1	2.80	13.3	2.69	12.5	2.60	12.1	2.48	11.8	2.41	11.0	2.26	
15	13.7	14.1	2.64	13.3	2.53	12.5	2.45	12.1	2.34	11.8	2.27	11.0	2.13	
60	-19.8	-20	12.1	6.85	11.5	6.58	10.8	6.22	10.4	5.88	10.0	5.56	9.4	5.25
	-18.8	-19	12.1	6.71	11.5	6.44	10.8	6.09	10.4	5.76	10.0	5.45	9.4	5.15
	-16.7	-17	12.1	6.42	11.5	6.16	10.8	5.82	10.4	5.51	10.0	5.22	9.4	4.93
	-13.7	-15	12.1	6.01	11.5	5.76	10.8	5.44	10.4	5.16	10.0	4.89	9.4	4.61
	-11.8	-13	12.1	5.75	11.5	5.50	10.8	5.20	10.4	4.93	10.0	4.68	9.4	4.41
	-9.8	-11	12.1	5.47	11.5	5.23	10.8	4.95	10.4	4.70	10.0	4.46	9.4	4.20
	-9.5	-10	12.1	5.43	11.5	5.19	10.8	4.91	10.4	4.66	10.0	4.42	9.4	4.16
	-8.5	-9.1	12.1	5.29	11.5	5.05	10.8	4.78	10.4	4.54	10.0	4.31	9.4	4.06
	-7	-7.6	12.1	5.09	11.5	4.85	10.8	4.59	10.4	4.37	10.0	4.15	9.4	3.90
	-5	-5.6	12.1	4.81	11.5	4.58	10.8	4.34	10.4	4.13	10.0	3.93	9.4	3.69
	-3	-3.7	12.1	4.54	11.5	4.31	10.8	4.09	10.4	3.89	10.0	3.71	9.4	3.48
	0	-0.7	12.1	4.12	11.5	3.90	10.8	3.71	10.4	3.54	10.0	3.37	9.4	3.16
	3	2.2	12.1	3.71	11.5	3.50	10.8	3.33	10.4	3.18	10.0	3.04	9.4	2.84
	5	4.1	12.1	3.43	11.5	3.23	10.8	3.07	10.4	2.95	10.0	2.82	9.4	2.63
	7	6	12.1	3.16	11.5	2.96	10.8	2.82	10.4	2.71	10.0	2.60	9.4	2.42
9	7.9	12.1	2.82	11.5	2.64	10.8	2.52	10.4	2.42	10.0	2.32	9.4	2.16	
11	9.8	12.1	2.63	11.5	2.46	10.8	2.35	10.4	2.26	10.0	2.17	9.4	2.01	
13	11.8	12.1	2.47	11.5	2.31	10.8	2.20	10.4	2.12	10.0	2.03	9.4	1.89	
15	13.7	12.1	2.33	11.5	2.18	10.8	2.08	10.4	2.00	10.0	1.92	9.4	1.78	
50	-19.8	-20	10.1	5.68	9.5	5.36	9.0	5.06	8.7	4.78	8.4	4.53	7.8	4.28
	-18.8	-19	10.1	5.56	9.5	5.24	9.0	4.96	8.7	4.69	8.4	4.44	7.8	4.19
	-16.7	-17	10.1	5.31	9.5	5.01	9.0	4.74	8.7	4.48	8.4	4.25	7.8	4.01
	-13.7	-15	10.1	4.96	9.5	4.68	9.0	4.43	8.7	4.19	8.4	3.98	7.8	3.75
	-11.8	-13	10.1	4.74	9.5	4.47	9.0	4.24	8.7	4.01	8.4	3.81	7.8	3.59
	-9.8	-11	10.1	4.51	9.5	4.25	9.0	4.03	8.7	3.81	8.4	3.63	7.8	3.42
	-9.5	-10	10.1	4.47	9.5	4.21	9.0	4.00	8.7	3.78	8.4	3.60	7.8	3.39
	-8.5	-9.1	10.1	4.36	9.5	4.10	9.0	3.90	8.7	3.69	8.4	3.51	7.8	3.31
	-7	-7.6	10.1	4.18	9.5	3.94	9.0	3.74	8.7	3.54	8.4	3.38	7.8	3.18
	-5	-5.6	10.1	3.95	9.5	3.72	9.0	3.54	8.7	3.35	8.4	3.20	7.8	3.00
	-3	-3.7	10.1	3.72	9.5	3.49	9.0	3.33	8.7	3.15	8.4	3.02	7.8	2.83
	0	-0.7	10.1	3.37	9.5	3.16	9.0	3.02	8.7	2.86	8.4	2.75	7.8	2.58
	3	2.2	10.1	3.01	9.5	2.83	9.0	2.71	8.7	2.57	8.4	2.48	7.8	2.32
	5	4.1	10.1	2.78	9.5	2.61	9.0	2.50	8.7	2.38	8.4	2.30	7.8	2.15
	7	6	10.1	2.55	9.5	2.39	9.0	2.30	8.7	2.18	8.4	2.12	7.8	1.97
9	7.9	10.1	2.30	9.5	2.15	9.0	2.08	8.7	1.97	8.4	1.91	7.8	1.78	
11	9.8	10.1	2.15	9.5	2.02	9.0	1.94	8.7	1.84	8.4	1.79	7.8	1.67	
13	11.8	10.1	2.02	9.5	1.89	9.0	1.82	8.7	1.73	8.4	1.68	7.8	1.57	
15	13.7	10.1	1.91	9.5	1.79	9.0	1.72	8.7	1.64	8.4	1.59	7.8	1.48	

Note

1. TC: Total Capacity(kW), PI : Power Input(kW, Comp. + Outdoor fan motor)
2. Capacity tables show the average value of conditions which may occur.

6. Capacity Tables

◆ ARUN080LSS0

Combination (%)	Outdoor air temp		Indoor air temp. °C DB											
			16		18		20		21		22		24	
	°C DB	°C WB	TC	PI	TC	PI	TC	PI	TC	PI	TC	PI	TC	PI
130	-19.8	-20	19.5	10.93	19.5	11.00	19.4	11.06	19.4	11.15	19.4	11.24	19.0	11.39
	-18.8	-19	20.0	10.97	20.0	11.05	19.8	11.11	19.8	11.20	19.8	11.29	19.4	11.43
	-16.7	-17	20.9	11.07	20.9	11.14	20.8	11.21	20.8	11.30	20.8	11.39	20.4	11.53
	-13.7	-15	22.3	11.22	22.3	11.29	22.2	11.35	22.2	11.44	22.2	11.53	21.7	11.02
	-11.8	-13	23.0	11.31	23.0	11.38	22.9	11.44	22.9	11.53	22.9	11.18	22.6	10.69
	-9.8	-11	23.8	11.40	23.8	11.47	23.7	11.53	23.7	11.15	23.7	10.81	23.5	10.34
	-9.5	-10	23.9	11.42	23.9	11.49	23.8	11.47	23.8	11.09	23.8	10.75	23.6	10.29
	-8.5	-9.1	24.4	11.46	24.4	11.53	24.2	11.27	24.2	10.90	24.1	10.56	24.1	10.12
	-7	-7.6	25.1	11.53	25.1	11.23	24.9	10.97	24.9	10.61	24.9	10.28	24.7	9.86
	-5	-5.6	26.0	11.12	26.0	10.82	25.8	10.57	25.8	10.22	25.8	9.91	25.6	9.51
	-3	-3.7	26.9	10.71	26.9	10.42	26.7	10.16	26.7	9.84	26.7	9.54	26.5	9.17
	0	-0.7	28.2	10.10	28.2	9.81	28.1	9.56	28.1	9.26	28.1	8.98	27.7	8.65
	3	2.2	29.6	9.49	29.6	9.20	29.4	8.95	29.4	8.68	29.4	8.42	27.7	8.13
	5	4.1	30.5	9.08	30.5	8.79	30.3	8.55	30.3	8.29	29.7	8.04	27.7	7.79
	7	6	31.4	8.67	31.4	8.39	31.2	8.14	30.8	7.91	29.7	7.67	27.7	7.44
	9	7.9	31.7	8.32	31.7	8.05	31.6	7.82	30.8	7.59	29.7	7.36	27.7	7.14
11	9.8	31.7	8.04	31.7	7.78	31.6	7.56	30.8	7.34	29.7	7.12	27.7	6.90	
13	11.8	31.7	7.75	31.7	7.50	31.6	7.28	30.8	7.07	29.7	6.86	27.7	6.65	
15	13.7	31.7	7.43	31.7	7.19	31.6	6.99	30.8	6.78	29.7	6.58	27.7	6.38	
120	-19.8	-20	19.4	11.00	19.4	11.06	19.2	11.15	19.2	11.24	19.2	11.39	18.9	11.49
	-18.8	-19	19.8	11.05	19.8	11.11	19.7	11.20	19.7	11.29	19.7	11.43	19.3	11.53
	-16.7	-17	20.8	11.14	20.8	11.21	20.7	11.30	20.7	11.39	20.7	11.53	20.2	11.20
	-13.7	-15	22.2	11.29	22.2	11.35	22.0	11.44	22.0	11.53	22.0	11.03	21.6	10.72
	-11.8	-13	22.9	11.38	22.9	11.44	22.7	11.53	22.7	11.18	22.7	10.72	22.4	10.42
	-9.8	-11	23.6	11.47	23.6	11.53	23.5	11.14	23.5	10.80	23.5	10.38	23.3	10.11
	-9.5	-10	23.8	11.49	23.8	11.47	23.6	11.08	23.6	10.75	23.6	10.33	23.4	10.06
	-8.5	-9.1	24.2	11.53	24.2	11.26	24.1	10.88	24.1	10.56	24.1	10.16	23.9	9.90
	-7	-7.6	24.9	11.21	24.9	10.94	24.7	10.58	24.7	10.28	24.7	9.91	24.5	9.66
	-5	-5.6	25.8	10.78	25.8	10.51	25.6	10.18	25.6	9.90	25.6	9.58	25.4	9.34
	-3	-3.7	26.7	10.34	26.7	10.08	26.5	9.78	26.5	9.52	26.5	9.24	26.0	9.03
	0	-0.7	28.0	9.69	28.0	9.44	27.9	9.19	27.9	8.96	27.9	8.74	26.0	8.55
	3	2.2	29.4	9.04	29.4	8.80	29.2	8.59	28.9	8.40	28.0	8.24	26.0	8.07
	5	4.1	30.3	8.61	30.3	8.38	29.9	8.19	28.9	8.02	28.0	7.91	26.0	7.76
	7	6	31.2	8.17	31.1	7.95	29.9	7.80	28.9	7.65	28.0	7.57	26.0	7.44
	9	7.9	31.4	7.83	31.1	7.62	29.9	7.47	28.9	7.33	28.0	7.26	26.0	7.13
11	9.8	31.4	7.56	31.1	7.35	29.9	7.21	28.9	7.07	28.0	7.00	26.0	6.88	
13	11.8	31.4	7.27	31.1	7.07	29.9	6.93	28.9	6.80	28.0	6.74	26.0	6.61	
15	13.7	31.4	6.96	31.1	6.77	29.9	6.64	28.9	6.51	28.0	6.45	26.0	6.33	
110	-19.8	-20	19.3	11.06	19.3	11.15	19.1	11.24	19.1	11.39	19.1	11.49	18.8	11.53
	-18.8	-19	19.7	11.11	19.7	11.20	19.6	11.29	19.6	11.43	19.6	11.53	19.2	11.36
	-16.7	-17	20.7	11.21	20.7	11.30	20.5	11.39	20.5	11.53	20.5	11.18	20.1	11.00
	-13.7	-15	22.0	11.35	22.0	11.44	21.9	11.53	21.9	10.99	21.9	10.67	21.9	10.49
	-11.8	-13	22.7	11.44	22.7	11.53	22.6	11.15	22.6	10.65	22.6	10.35	22.6	10.17
	-9.8	-11	23.5	11.53	23.5	11.10	23.4	10.75	23.4	10.29	23.4	10.01	23.3	9.82
	-9.5	-10	23.6	11.46	23.6	11.03	23.5	10.69	23.5	10.24	23.5	9.96	23.4	9.77
	-8.5	-9.1	24.1	11.23	24.1	10.82	23.9	10.48	23.9	10.06	23.9	9.79	23.4	9.60
	-7	-7.6	24.8	10.87	24.8	10.49	24.6	10.18	24.6	9.79	24.6	9.54	23.4	9.35
	-5	-5.6	25.6	10.40	25.6	10.05	25.5	9.78	25.5	9.43	25.0	9.20	23.4	9.00
	-3	-3.7	26.5	9.92	26.5	9.62	26.4	9.37	25.9	9.07	25.0	8.86	23.4	8.66
	0	-0.7	27.9	9.21	27.9	8.96	26.8	8.77	25.9	8.53	25.0	8.36	23.4	8.15
	3	2.2	29.2	8.50	28.5	8.31	26.8	8.16	25.9	7.99	25.0	7.85	23.4	7.64
	5	4.1	30.1	8.03	28.5	7.88	26.8	7.76	25.9	7.63	25.0	7.51	23.4	7.29
	7	6	30.2	7.55	28.5	7.44	26.8	7.36	25.9	7.27	25.0	7.17	23.4	6.95
	9	7.9	30.2	7.21	28.5	7.10	26.8	7.02	25.9	6.94	25.0	6.85	23.4	6.64
11	9.8	30.2	6.93	28.5	6.82	26.8	6.75	25.9	6.66	25.0	6.58	23.4	6.38	
13	11.8	30.2	6.63	28.5	6.53	26.8	6.45	25.9	6.37	25.0	6.29	23.4	6.10	
15	13.7	30.2	6.31	28.5	6.21	26.8	6.14	25.9	6.07	25.0	5.99	23.4	5.81	

6. Capacity Tables

Combination (%)	Outdoor air temp		Indoor air temp. °C DB											
			16		18		20		21		22		24	
	°C DB	°C WB	TC	PI	TC	PI	TC	PI	TC	PI	TC	PI	TC	PI
100	-19.8	-20	19.2	11.84	19.2	11.78	19.1	11.64	19.1	11.63	19.1	11.62	18.7	11.53
	-18.8	-19	19.6	11.81	19.5	11.75	19.5	11.69	19.5	11.60	19.5	11.53	19.1	11.33
	-16.7	-17	20.5	11.74	20.5	11.68	20.5	11.79	20.3	11.53	20.3	11.11	19.9	10.91
	-13.7	-15	21.9	11.65	21.9	11.59	21.8	11.53	21.8	10.92	21.8	10.51	21.4	10.30
	-11.8	-13	22.6	11.59	22.5	11.53	22.5	11.11	22.5	10.53	22.5	10.13	21.4	9.92
	-9.8	-11	23.4	11.53	23.4	11.06	23.3	10.67	23.3	10.11	22.9	9.73	21.4	9.52
	-9.5	-10	23.5	11.46	23.5	10.99	23.4	10.61	23.4	10.05	22.9	9.67	21.4	9.46
	-8.5	-9.1	23.9	11.21	23.9	10.75	23.8	10.39	23.7	9.85	22.9	9.47	21.4	9.25
	-7	-7.6	25.0	10.83	24.9	10.40	24.5	10.05	23.7	9.54	22.9	9.17	21.4	8.95
	-5	-5.6	26.1	10.33	25.9	9.92	24.5	9.61	23.7	9.13	22.9	8.77	21.4	8.55
	-3	-3.7	26.9	9.83	26.1	9.45	24.5	9.17	23.7	8.72	22.9	8.37	21.4	8.14
	0	-0.7	27.6	9.07	26.1	8.74	24.5	8.51	23.7	8.10	22.9	7.77	21.4	7.54
	3	2.2	27.6	8.32	26.1	8.03	24.5	7.84	23.7	7.48	22.9	7.17	21.4	6.93
	5	4.1	27.6	7.82	26.1	7.56	24.5	7.40	23.7	7.07	22.9	6.77	21.4	6.53
	7	6	27.6	7.31	26.1	7.08	24.5	6.96	23.7	6.66	22.9	6.37	21.4	6.13
	9	7.9	27.6	6.93	26.1	6.72	24.5	6.60	23.7	6.31	22.9	6.04	21.4	5.81
11	9.8	27.6	6.61	26.1	6.40	24.5	6.29	23.7	6.02	22.9	5.76	21.4	5.54	
13	11.8	27.6	6.27	26.1	6.07	24.5	5.97	23.7	5.71	22.9	5.46	21.4	5.25	
15	13.7	27.6	5.91	26.1	5.72	24.5	5.62	23.7	5.38	22.9	5.15	21.4	4.95	
90	-19.8	-20	19.1	10.89	19.1	11.03	19.0	11.13	19.0	11.18	19.0	10.81	18.6	10.29
	-18.8	-19	19.6	10.93	19.5	11.08	19.4	11.18	19.4	10.99	19.4	10.63	19.0	10.12
	-16.7	-17	20.5	11.03	20.5	11.18	20.4	10.78	20.4	10.59	20.4	10.24	19.5	9.75
	-13.7	-15	21.9	11.18	21.9	10.58	21.7	10.21	21.7	10.02	21.0	9.69	19.5	9.22
	-11.8	-13	22.6	10.76	22.5	10.20	22.4	9.85	21.7	9.66	21.0	9.35	19.5	8.88
	-9.8	-11	23.4	10.33	23.4	9.81	22.4	9.48	21.7	9.28	21.0	8.98	19.5	8.53
	-9.5	-10	23.5	10.26	23.5	9.75	22.4	9.42	21.7	9.22	21.0	8.93	19.5	8.48
	-8.5	-9.1	23.9	10.05	23.8	9.55	22.4	9.23	21.7	9.03	21.0	8.74	19.5	8.30
	-7	-7.6	25.0	9.72	23.8	9.25	22.4	8.95	21.7	8.75	21.0	8.47	19.5	8.04
	-5	-5.6	25.3	9.29	23.8	8.86	22.4	8.57	21.7	8.37	21.0	8.10	19.5	7.69
	-3	-3.7	25.3	8.85	23.8	8.46	22.4	8.19	21.7	7.99	21.0	7.74	19.5	7.33
	0	-0.7	25.3	8.20	23.8	7.86	22.4	7.63	21.7	7.42	21.0	7.19	19.5	6.80
	3	2.2	25.3	7.55	23.8	7.27	22.4	7.06	21.7	6.85	21.0	6.64	19.5	6.28
	5	4.1	25.3	7.12	23.8	6.87	22.4	6.68	21.7	6.47	21.0	6.27	19.5	5.92
	7	6	25.3	6.68	23.8	6.48	22.4	6.30	21.7	6.09	21.0	5.91	19.5	5.57
	9	7.9	25.3	6.28	23.8	6.09	22.4	5.93	21.7	5.72	21.0	5.55	19.5	5.24
11	9.8	25.3	5.88	23.8	5.70	22.4	5.55	21.7	5.36	21.0	5.20	19.5	4.90	
13	11.8	25.3	5.48	23.8	5.31	22.4	5.17	21.7	4.99	21.0	4.85	19.5	4.57	
15	13.7	25.3	5.08	23.8	4.92	22.4	4.79	21.7	4.63	21.0	4.49	19.5	4.24	
80	-19.8	-20	18.9	9.62	18.9	9.76	18.9	9.91	18.9	9.58	18.7	9.13	17.4	8.71
	-18.8	-19	19.4	9.67	19.4	9.91	19.4	9.74	19.4	9.41	18.7	8.98	17.4	8.56
	-16.7	-17	20.1	9.91	20.1	9.55	20.1	9.38	19.5	9.07	18.7	8.65	17.4	8.25
	-13.7	-15	20.1	9.38	20.1	9.04	20.1	8.87	19.5	8.57	18.7	8.19	17.4	7.80
	-11.8	-13	20.5	9.04	20.1	8.72	20.1	8.55	19.5	8.25	18.7	7.89	17.4	7.52
	-9.8	-11	21.4	8.68	20.8	8.38	20.1	8.21	19.5	7.92	18.7	7.58	17.4	7.23
	-9.5	-10	21.6	8.63	21.0	8.33	20.1	8.16	19.5	7.87	18.7	7.53	17.4	7.18
	-8.5	-9.1	22.0	8.45	21.4	8.16	20.1	7.99	19.5	7.71	18.7	7.38	17.4	7.04
	-7	-7.6	22.7	8.18	21.4	7.91	20.1	7.74	19.5	7.46	18.7	7.15	17.4	6.81
	-5	-5.6	22.7	7.83	21.4	7.57	20.1	7.40	19.5	7.13	18.7	6.83	17.4	6.52
	-3	-3.7	22.7	7.47	21.4	7.23	20.1	7.06	19.5	6.80	18.7	6.52	17.4	6.22
	0	-0.7	22.7	6.94	21.4	6.72	20.1	6.55	19.5	6.30	18.7	6.06	17.4	5.78
	3	2.2	22.7	6.40	21.4	6.21	20.1	6.04	19.5	5.80	18.7	5.59	17.4	5.34
	5	4.1	22.7	6.05	21.4	5.87	20.1	5.70	19.5	5.47	18.7	5.28	17.4	5.04
	7	6	22.7	5.69	21.4	5.53	20.1	5.36	19.5	5.14	18.7	4.97	17.4	4.75
	9	7.9	22.7	5.34	21.4	5.19	20.1	5.04	19.5	4.83	18.7	4.67	17.4	4.46
11	9.8	22.7	4.96	21.4	4.82	20.1	4.67	19.5	4.48	18.7	4.33	17.4	4.14	
13	11.8	22.7	4.63	21.4	4.50	20.1	4.36	19.5	4.18	18.7	4.04	17.4	3.86	
15	13.7	22.7	4.36	21.4	4.23	20.1	4.11	19.5	3.94	18.7	3.81	17.4	3.64	

6. Capacity Tables

Combination (%)	Outdoor air temp		Indoor air temp. °C DB											
			16		18		20		21		22		24	
	°C DB	°C WB	TC	PI	TC	PI	TC	PI	TC	PI	TC	PI	TC	PI
70	-19.8	-20	18.8	9.63	18.1	9.68	17.1	9.33	16.5	8.85	16.0	8.41	14.9	7.97
	-18.8	-19	19.2	9.68	18.1	9.49	17.1	9.15	16.5	8.68	16.0	8.25	14.9	7.83
	-16.7	-17	19.2	9.29	18.1	9.11	17.1	8.78	16.5	8.33	16.0	7.93	14.9	7.51
	-13.7	-15	19.2	8.74	18.1	8.56	17.1	8.25	16.5	7.83	16.0	7.46	14.9	7.07
	-11.8	-13	19.2	8.40	18.1	8.21	17.1	7.91	16.5	7.52	16.0	7.17	14.9	6.79
	-9.8	-11	19.2	8.03	18.1	7.84	17.1	7.56	16.5	7.18	16.0	6.86	14.9	6.49
	-9.5	-10	19.2	7.98	18.1	7.79	17.1	7.51	16.5	7.13	16.0	6.81	14.9	6.45
	-8.5	-9.1	19.2	7.79	18.1	7.60	17.1	7.33	16.5	6.97	16.0	6.66	14.9	6.30
	-7	-7.6	19.2	7.52	18.1	7.33	17.1	7.07	16.5	6.72	16.0	6.42	14.9	6.08
	-5	-5.6	19.2	7.15	18.1	6.96	17.1	6.71	16.5	6.39	16.0	6.11	14.9	5.78
	-3	-3.7	19.2	6.79	18.1	6.59	17.1	6.36	16.5	6.05	16.0	5.81	14.9	5.48
	0	-0.7	19.2	6.24	18.1	6.04	17.1	5.83	16.5	5.55	16.0	5.34	14.9	5.04
	3	2.2	19.2	5.69	18.1	5.49	17.1	5.30	16.5	5.06	16.0	4.88	14.9	4.60
	5	4.1	19.2	5.32	18.1	5.12	17.1	4.95	16.5	4.72	16.0	4.57	14.9	4.30
	7	6	19.2	4.96	18.1	4.76	17.1	4.60	16.5	4.39	16.0	4.26	14.9	4.00
	9	7.9	19.2	4.48	18.1	4.30	17.1	4.15	16.5	3.96	16.0	3.84	14.9	3.61
11	9.8	19.2	4.17	18.1	4.00	17.1	3.87	16.5	3.69	16.0	3.58	14.9	3.37	
13	11.8	19.2	3.90	18.1	3.74	17.1	3.62	16.5	3.45	16.0	3.35	14.9	3.15	
15	13.7	19.2	3.68	18.1	3.53	17.1	3.41	16.5	3.26	16.0	3.16	14.9	2.97	
60	-19.8	-20	16.5	9.54	15.6	9.16	14.6	8.65	14.1	8.18	13.7	7.74	12.8	7.31
	-18.8	-19	16.5	9.34	15.6	8.97	14.6	8.48	14.1	8.02	13.7	7.59	12.8	7.17
	-16.7	-17	16.5	8.94	15.6	8.58	14.6	8.11	14.1	7.67	13.7	7.27	12.8	6.86
	-13.7	-15	16.5	8.37	15.6	8.01	14.6	7.58	14.1	7.18	13.7	6.80	12.8	6.42
	-11.8	-13	16.5	8.00	15.6	7.65	14.6	7.24	14.1	6.87	13.7	6.51	12.8	6.14
	-9.8	-11	16.5	7.62	15.6	7.28	14.6	6.89	14.1	6.54	13.7	6.20	12.8	5.84
	-9.5	-10	16.5	7.56	15.6	7.22	14.6	6.84	14.1	6.49	13.7	6.16	12.8	5.80
	-8.5	-9.1	16.5	7.37	15.6	7.03	14.6	6.66	14.1	6.32	13.7	6.00	12.8	5.65
	-7	-7.6	16.5	7.08	15.6	6.75	14.6	6.40	14.1	6.08	13.7	5.77	12.8	5.43
	-5	-5.6	16.5	6.70	15.6	6.38	14.6	6.04	14.1	5.75	13.7	5.47	12.8	5.13
	-3	-3.7	16.5	6.31	15.6	6.00	14.6	5.69	14.1	5.42	13.7	5.16	12.8	4.84
	0	-0.7	16.5	5.74	15.6	5.44	14.6	5.16	14.1	4.93	13.7	4.70	12.8	4.40
	3	2.2	16.5	5.16	15.6	4.87	14.6	4.63	14.1	4.43	13.7	4.24	12.8	3.96
	5	4.1	16.5	4.78	15.6	4.49	14.6	4.28	14.1	4.10	13.7	3.93	12.8	3.66
	7	6	16.5	4.40	15.6	4.12	14.6	3.93	14.1	3.77	13.7	3.62	12.8	3.37
	9	7.9	16.5	3.92	15.6	3.67	14.6	3.50	14.1	3.37	13.7	3.23	12.8	3.00
11	9.8	16.5	3.66	15.6	3.43	14.6	3.27	14.1	3.14	13.7	3.02	12.8	2.80	
13	11.8	16.5	3.43	15.6	3.21	14.6	3.06	14.1	2.95	13.7	2.83	12.8	2.63	
15	13.7	16.5	3.24	15.6	3.04	14.6	2.90	14.1	2.78	13.7	2.67	12.8	2.48	
50	-19.8	-20	13.8	7.90	13.0	7.46	12.2	7.05	11.8	6.66	11.4	6.30	10.6	5.95
	-18.8	-19	13.8	7.74	13.0	7.30	12.2	6.90	11.8	6.52	11.4	6.18	10.6	5.83
	-16.7	-17	13.8	7.40	13.0	6.98	12.2	6.60	11.8	6.24	11.4	5.91	10.6	5.58
	-13.7	-15	13.8	6.91	13.0	6.51	12.2	6.17	11.8	5.83	11.4	5.54	10.6	5.22
	-11.8	-13	13.8	6.60	13.0	6.22	12.2	5.90	11.8	5.58	11.4	5.30	10.6	5.00
	-9.8	-11	13.8	6.28	13.0	5.91	12.2	5.61	11.8	5.31	11.4	5.05	10.6	4.76
	-9.5	-10	13.8	6.23	13.0	5.87	12.2	5.57	11.8	5.27	11.4	5.01	10.6	4.72
	-8.5	-9.1	13.8	6.07	13.0	5.71	12.2	5.42	11.8	5.13	11.4	4.89	10.6	4.60
	-7	-7.6	13.8	5.82	13.0	5.48	12.2	5.21	11.8	4.93	11.4	4.70	10.6	4.42
	-5	-5.6	13.8	5.50	13.0	5.17	12.2	4.92	11.8	4.66	11.4	4.45	10.6	4.18
	-3	-3.7	13.8	5.17	13.0	4.86	12.2	4.63	11.8	4.39	11.4	4.20	10.6	3.94
	0	-0.7	13.8	4.68	13.0	4.40	12.2	4.20	11.8	3.98	11.4	3.82	10.6	3.58
	3	2.2	13.8	4.20	13.0	3.94	12.2	3.77	11.8	3.58	11.4	3.45	10.6	3.23
	5	4.1	13.8	3.87	13.0	3.63	12.2	3.49	11.8	3.31	11.4	3.20	10.6	2.99
	7	6	13.8	3.55	13.0	3.32	12.2	3.20	11.8	3.04	11.4	2.94	10.6	2.75
	9	7.9	13.8	3.20	13.0	3.00	12.2	2.89	11.8	2.74	11.4	2.66	10.6	2.48
11	9.8	13.8	3.00	13.0	2.81	12.2	2.70	11.8	2.57	11.4	2.49	10.6	2.32	
13	11.8	13.8	2.81	13.0	2.63	12.2	2.54	11.8	2.41	11.4	2.34	10.6	2.18	
15	13.7	13.8	2.66	13.0	2.49	12.2	2.40	11.8	2.28	11.4	2.21	10.6	2.06	

Note

1. TC: Total Capacity(kW), PI : Power Input(kW, Comp. + Outdoor fan motor)
2. Capacity tables show the average value of conditions which may occur.

6. Capacity Tables

◆ ARUN100LSS0

Combination (%)	Outdoor air temp		Indoor air temp. °C DB											
			16		18		20		21		22		24	
	°C DB	°C WB	TC	PI	TC	PI	TC	PI	TC	PI	TC	PI	TC	PI
130	-19.8	-20	25.4	14.36	25.4	14.50	25.2	14.62	25.2	14.81	25.2	14.99	24.6	15.27
	-18.8	-19	25.8	14.45	25.8	14.59	25.6	14.71	25.6	14.90	25.6	15.08	25.0	15.36
	-16.7	-17	26.7	14.65	26.7	14.79	26.5	14.91	26.5	15.10	26.5	15.28	25.9	15.56
	-13.7	-15	28.0	14.93	28.0	15.07	27.8	15.19	27.8	15.38	27.8	15.56	27.1	14.74
	-11.8	-13	28.8	15.11	28.8	15.25	28.6	15.37	28.6	15.56	28.6	14.99	27.9	14.22
	-9.8	-11	29.7	15.30	29.7	15.44	29.5	15.56	29.5	14.93	29.5	14.39	28.8	13.67
	-9.5	-10	29.8	15.32	29.8	15.47	29.6	15.46	29.6	14.84	29.6	14.30	28.9	13.59
	-8.5	-9.1	30.4	15.42	30.4	15.56	30.2	15.12	30.2	14.52	30.0	14.00	29.3	13.32
	-7	-7.6	31.3	15.56	31.3	15.04	31.1	14.62	31.1	14.05	31.1	13.56	30.0	12.91
	-5	-5.6	32.5	14.85	32.5	14.36	32.3	13.95	32.3	13.42	32.3	12.96	30.8	12.36
	-3	-3.7	33.7	14.14	33.7	13.67	33.5	13.29	33.5	12.80	33.5	12.36	31.6	11.82
	0	-0.7	35.4	13.07	35.4	12.64	35.2	12.28	35.2	11.85	35.2	11.46	32.9	11.00
	3	2.2	37.2	12.01	37.2	11.61	37.0	11.28	37.0	10.91	37.0	10.56	34.2	10.18
	5	4.1	38.4	11.29	38.4	10.93	38.2	10.61	38.2	10.28	37.1	9.97	34.5	9.63
	7	6	39.5	10.58	39.5	10.24	39.3	9.95	38.5	9.66	37.1	9.37	34.5	9.09
	9	7.9	39.5	9.97	39.5	9.65	39.4	9.37	38.5	9.10	37.1	8.83	34.5	8.56
11	9.8	39.5	9.44	39.5	9.13	39.4	8.87	38.5	8.61	37.1	8.35	34.5	8.10	
13	11.8	39.5	8.87	39.5	8.59	39.4	8.34	38.5	8.09	37.1	7.85	34.5	7.62	
15	13.7	39.5	8.28	39.5	8.01	39.4	7.78	38.5	7.55	37.1	7.33	34.5	7.11	
120	-19.8	-20	25.2	14.50	25.2	14.62	25.0	14.81	25.0	14.99	25.0	15.27	24.4	15.47
	-18.8	-19	25.6	14.59	25.6	14.71	25.5	14.90	25.5	15.08	25.5	15.36	24.8	15.56
	-16.7	-17	26.5	14.79	26.5	14.91	26.4	15.10	26.4	15.28	26.4	15.56	25.7	15.03
	-13.7	-15	27.8	15.07	27.8	15.19	27.6	15.38	27.6	15.56	27.6	14.76	26.9	14.28
	-11.8	-13	28.6	15.25	28.6	15.37	28.4	15.56	28.4	14.99	28.4	14.25	27.7	13.80
	-9.8	-11	29.4	15.44	29.4	15.56	29.3	14.92	29.3	14.39	29.3	13.72	28.6	13.30
	-9.5	-10	29.6	15.47	29.6	15.45	29.4	14.82	29.4	14.30	29.4	13.64	28.7	13.23
	-8.5	-9.1	30.2	15.56	30.2	15.11	30.0	14.50	30.0	14.00	29.9	13.38	29.1	12.97
	-7	-7.6	31.1	15.02	31.1	14.58	30.9	14.02	30.9	13.55	30.5	12.98	29.7	12.60
	-5	-5.6	32.3	14.30	32.3	13.89	32.1	13.37	32.1	12.94	32.1	12.44	30.6	12.10
	-3	-3.7	33.4	13.58	33.4	13.19	33.2	12.73	33.2	12.34	33.2	11.91	31.4	11.59
	0	-0.7	35.2	12.50	35.2	12.15	35.0	11.77	35.0	11.44	34.8	11.11	32.4	10.84
	3	2.2	37.0	11.42	37.0	11.10	36.7	10.80	36.0	10.54	34.8	10.31	32.4	10.09
	5	4.1	38.1	10.70	38.1	10.41	37.3	10.16	36.0	9.94	34.9	9.78	32.4	9.59
	7	6	39.2	9.98	38.8	9.71	37.3	9.52	36.0	9.34	34.9	9.25	32.4	9.08
	9	7.9	39.2	9.40	38.8	9.15	37.3	8.97	36.0	8.79	34.9	8.71	32.4	8.56
11	9.8	39.2	8.89	38.8	8.65	37.3	8.48	36.0	8.32	34.9	8.24	32.4	8.09	
13	11.8	39.2	8.36	38.8	8.13	37.3	7.97	36.0	7.82	34.9	7.75	32.4	7.61	
15	13.7	39.2	7.80	38.8	7.59	37.3	7.44	36.0	7.29	34.9	7.23	32.4	7.10	
110	-19.8	-20	25.0	14.62	25.0	14.81	24.9	14.99	24.9	15.27	24.9	15.47	24.3	15.56
	-18.8	-19	25.5	14.71	25.5	14.90	25.3	15.08	25.3	15.36	25.3	15.56	24.7	15.30
	-16.7	-17	26.4	14.91	26.4	15.10	26.2	15.28	26.2	15.56	26.2	15.01	25.5	14.74
	-13.7	-15	27.7	15.19	27.7	15.38	27.5	15.56	27.5	14.71	27.5	14.22	27.5	13.95
	-11.8	-13	28.5	15.37	28.5	15.56	28.3	14.96	28.3	14.18	28.3	13.71	28.3	13.45
	-9.8	-11	29.3	15.56	29.3	14.87	29.1	14.32	29.1	13.61	29.1	13.19	28.5	12.92
	-9.5	-10	29.5	15.45	29.5	14.77	29.3	14.23	29.3	13.53	29.3	13.11	29.0	12.84
	-8.5	-9.1	30.0	15.07	30.0	14.42	29.9	13.91	29.9	13.25	29.9	12.85	29.2	12.58
	-7	-7.6	30.9	14.50	30.9	13.91	30.7	13.43	30.7	12.82	30.7	12.45	29.2	12.18
	-5	-5.6	32.1	13.75	32.1	13.22	31.9	12.80	31.9	12.26	31.3	11.92	29.2	11.66
	-3	-3.7	33.3	13.00	33.3	12.53	33.0	12.16	32.4	11.70	31.3	11.40	29.2	11.13
	0	-0.7	35.0	11.86	35.0	11.50	33.5	11.21	32.4	10.85	31.3	10.61	29.2	10.34
	3	2.2	36.8	10.73	35.7	10.46	33.5	10.25	32.4	10.00	31.3	9.82	29.2	9.55
	5	4.1	37.7	9.98	35.7	9.78	33.5	9.62	32.4	9.44	31.3	9.29	29.2	9.02
	7	6	37.7	9.23	35.7	9.09	33.5	8.98	32.4	8.88	31.3	8.76	29.2	8.49
	9	7.9	37.7	8.66	35.7	8.53	33.5	8.43	32.4	8.33	31.3	8.22	29.2	7.97
11	9.8	37.7	8.16	35.7	8.04	33.5	7.95	32.4	7.85	31.3	7.75	29.2	7.51	
13	11.8	37.7	7.63	35.7	7.52	33.5	7.43	32.4	7.34	31.3	7.25	29.2	7.02	
15	13.7	37.7	7.08	35.7	6.97	33.5	6.89	32.4	6.81	31.3	6.72	29.2	6.52	

6. Capacity Tables

Combination (%)	Outdoor air temp		Indoor air temp. °C DB											
			16		18		20		21		22		24	
	°C DB	°C WB	TC	PI	TC	PI	TC	PI	TC	PI	TC	PI	TC	PI
100	-19.8	-20	24.9	15.01	24.9	15.12	24.8	15.19	24.8	15.39	24.8	15.53	24.2	15.56
	-18.8	-19	25.4	15.07	25.2	15.18	25.2	15.28	25.2	15.44	25.2	15.56	24.6	15.26
	-16.7	-17	26.1	15.18	26.1	15.29	26.1	15.48	26.0	15.56	26.0	14.93	25.3	14.62
	-13.7	-15	27.5	15.35	27.5	15.46	27.4	15.56	27.4	14.62	27.4	14.02	26.7	13.72
	-11.8	-13	28.3	15.45	28.2	15.56	28.2	14.91	28.2	14.02	28.2	13.45	26.7	13.15
	-9.8	-11	29.1	15.56	29.1	14.82	29.0	14.23	29.0	13.40	28.6	12.85	26.7	12.55
	-9.5	-10	29.3	15.44	29.3	14.71	29.2	14.13	29.2	13.30	28.6	12.76	26.7	12.46
	-8.5	-9.1	29.9	15.05	29.9	14.35	29.7	13.79	29.6	12.99	28.6	12.45	26.7	12.15
	-7	-7.6	31.3	14.45	31.1	13.80	30.6	13.27	29.6	12.52	28.6	12.00	26.7	11.70
	-5	-5.6	32.6	13.67	32.3	13.06	30.6	12.59	29.6	11.89	28.6	11.40	26.7	11.10
	-3	-3.7	33.6	12.88	32.6	12.33	30.6	11.91	29.6	11.27	28.6	10.80	26.7	10.50
	0	-0.7	34.5	11.69	32.6	11.22	30.6	10.89	29.6	10.33	28.6	9.89	26.7	9.59
	3	2.2	34.5	10.51	32.6	10.12	30.6	9.86	29.6	9.39	28.6	8.99	26.7	8.69
	5	4.1	34.5	9.72	32.6	9.39	30.6	9.18	29.6	8.76	28.6	8.38	26.7	8.09
	7	6	34.5	8.93	32.6	8.65	30.6	8.50	29.6	8.13	28.6	7.78	26.7	7.48
	9	7.9	34.5	8.17	32.6	7.91	30.6	7.77	29.6	7.44	28.6	7.11	26.7	6.84
11	9.8	34.5	7.46	32.6	7.22	30.6	7.10	29.6	6.79	28.6	6.50	26.7	6.25	
13	11.8	34.5	6.72	32.6	6.50	30.6	6.39	29.6	6.12	28.6	5.85	26.7	5.63	
15	13.7	34.5	5.94	32.6	5.75	30.6	5.65	29.6	5.41	28.6	5.17	26.7	4.98	
90	-19.8	-20	24.8	14.10	24.8	14.38	24.7	14.58	24.7	14.67	24.7	14.16	24.1	13.44
	-18.8	-19	25.4	14.20	25.2	14.48	25.1	14.67	25.1	14.40	25.1	13.90	24.4	13.19
	-16.7	-17	26.1	14.39	26.1	14.67	26.0	14.11	26.0	13.84	26.0	13.35	24.4	12.67
	-13.7	-15	27.5	14.67	27.5	13.82	27.3	13.30	27.1	13.03	26.3	12.58	24.4	11.93
	-11.8	-13	28.3	14.08	28.2	13.28	28.0	12.78	27.1	12.51	26.3	12.08	24.4	11.46
	-9.8	-11	29.1	13.45	29.1	12.71	28.0	12.24	27.1	11.97	26.3	11.57	24.4	10.96
	-9.5	-10	29.3	13.35	29.3	12.62	28.0	12.16	27.1	11.89	26.3	11.49	24.4	10.89
	-8.5	-9.1	29.9	13.04	29.7	12.33	28.0	11.89	27.1	11.62	26.3	11.23	24.4	10.64
	-7	-7.6	31.3	12.57	29.7	11.91	28.0	11.48	27.1	11.22	26.3	10.84	24.4	10.27
	-5	-5.6	31.6	11.94	29.7	11.34	28.0	10.94	27.1	10.68	26.3	10.32	24.4	9.77
	-3	-3.7	31.6	11.31	29.7	10.76	28.0	10.40	27.1	10.14	26.3	9.80	24.4	9.28
	0	-0.7	31.6	10.36	29.7	9.91	28.0	9.59	27.1	9.33	26.3	9.03	24.4	8.54
	3	2.2	31.6	9.42	29.7	9.05	28.0	8.78	27.1	8.52	26.3	8.25	24.4	7.79
	5	4.1	31.6	8.79	29.7	8.48	28.0	8.24	27.1	7.98	26.3	7.73	24.4	7.30
	7	6	31.6	8.16	29.7	7.91	28.0	7.70	27.1	7.44	26.3	7.21	24.4	6.80
	9	7.9	31.6	7.59	29.7	7.35	28.0	7.16	27.1	6.91	26.3	6.71	24.4	6.33
11	9.8	31.6	7.01	29.7	6.80	28.0	6.62	27.1	6.39	26.3	6.20	24.4	5.85	
13	11.8	31.6	6.44	29.7	6.24	28.0	6.08	27.1	5.87	26.3	5.69	24.4	5.37	
15	13.7	31.6	5.87	29.7	5.69	28.0	5.53	27.1	5.35	26.3	5.19	24.4	4.89	
80	-19.8	-20	24.6	12.44	24.6	12.72	24.6	13.01	24.3	12.54	23.4	11.92	21.8	11.33
	-18.8	-19	25.0	12.53	25.0	13.01	25.0	12.77	24.3	12.31	23.4	11.70	21.8	11.12
	-16.7	-17	25.0	13.01	25.0	12.50	25.0	12.26	24.3	11.82	23.4	11.24	21.8	10.69
	-13.7	-15	25.0	12.24	25.0	11.77	25.0	11.54	24.3	11.12	23.4	10.59	21.8	10.07
	-11.8	-13	25.9	11.76	25.2	11.31	25.0	11.08	24.3	10.67	23.4	10.17	21.8	9.68
	-9.8	-11	26.9	11.25	26.1	10.83	25.0	10.60	24.3	10.21	23.4	9.74	21.8	9.26
	-9.5	-10	27.0	11.17	26.2	10.75	25.0	10.53	24.3	10.14	23.4	9.67	21.8	9.20
	-8.5	-9.1	27.5	10.92	26.7	10.51	25.0	10.29	24.3	9.90	23.4	9.45	21.8	8.99
	-7	-7.6	28.3	10.53	26.7	10.15	25.0	9.93	24.3	9.55	23.4	9.13	21.8	8.69
	-5	-5.6	28.3	10.02	26.7	9.66	25.0	9.44	24.3	9.08	23.4	8.69	21.8	8.27
	-3	-3.7	28.3	9.51	26.7	9.18	25.0	8.96	24.3	8.62	23.4	8.25	21.8	7.86
	0	-0.7	28.3	8.74	26.7	8.45	25.0	8.24	24.3	7.91	23.4	7.60	21.8	7.24
	3	2.2	28.3	7.97	26.7	7.72	25.0	7.51	24.3	7.21	23.4	6.94	21.8	6.62
	5	4.1	28.3	7.46	26.7	7.24	25.0	7.03	24.3	6.75	23.4	6.51	21.8	6.21
	7	6	28.3	6.95	26.7	6.75	25.0	6.55	24.3	6.28	23.4	6.07	21.8	5.80
	9	7.9	28.3	6.53	26.7	6.34	25.0	6.15	24.3	5.89	23.4	5.70	21.8	5.44
11	9.8	28.3	6.06	26.7	5.88	25.0	5.71	24.3	5.47	23.4	5.29	21.8	5.05	
13	11.8	28.3	5.66	26.7	5.49	25.0	5.33	24.3	5.11	23.4	4.94	21.8	4.72	
15	13.7	28.3	5.32	26.7	5.17	25.0	5.02	24.3	4.81	23.4	4.65	21.8	4.44	

6. Capacity Tables

Combination (%)	Outdoor air temp		Indoor air temp. °C DB											
			16		18		20		21		22		24	
	°C DB	°C WB	TC	PI	TC	PI	TC	PI	TC	PI	TC	PI	TC	PI
70	-19.8	-20	22.9	12.61	22.7	12.71	21.3	12.21	20.6	11.55	20.0	10.94	18.6	10.35
	-18.8	-19	23.6	12.71	22.7	12.45	21.3	11.97	20.6	11.32	20.0	10.73	18.6	10.15
	-16.7	-17	24.0	12.17	22.7	11.91	21.3	11.45	20.6	10.84	20.0	10.28	18.6	9.72
	-13.7	-15	24.0	11.39	22.7	11.14	21.3	10.71	20.6	10.14	20.0	9.64	18.6	9.11
	-11.8	-13	24.0	10.90	22.7	10.65	21.3	10.24	20.6	9.70	20.0	9.23	18.6	8.72
	-9.8	-11	24.0	10.39	22.7	10.13	21.3	9.75	20.6	9.24	20.0	8.80	18.6	8.31
	-9.5	-10	24.0	10.31	22.7	10.06	21.3	9.68	20.6	9.17	20.0	8.74	18.6	8.25
	-8.5	-9.1	24.0	10.05	22.7	9.80	21.3	9.43	20.6	8.94	20.0	8.52	18.6	8.05
	-7	-7.6	24.0	9.66	22.7	9.41	21.3	9.06	20.6	8.60	20.0	8.20	18.6	7.74
	-5	-5.6	24.0	9.15	22.7	8.90	21.3	8.57	20.6	8.13	20.0	7.77	18.6	7.33
	-3	-3.7	24.0	8.63	22.7	8.38	21.3	8.08	20.6	7.67	20.0	7.34	18.6	6.93
	0	-0.7	24.0	7.86	22.7	7.61	21.3	7.34	20.6	6.98	20.0	6.70	18.6	6.32
	3	2.2	24.0	7.08	22.7	6.84	21.3	6.60	20.6	6.29	20.0	6.06	18.6	5.70
	5	4.1	24.0	6.57	22.7	6.32	21.3	6.11	20.6	5.82	20.0	5.63	18.6	5.30
	7	6	24.0	6.05	22.7	5.81	21.3	5.62	20.6	5.36	20.0	5.20	18.6	4.89
	9	7.9	24.0	5.47	22.7	5.25	21.3	5.07	20.6	4.84	20.0	4.70	18.6	4.41
11	9.8	24.0	5.09	22.7	4.89	21.3	4.72	20.6	4.51	20.0	4.37	18.6	4.11	
13	11.8	24.0	4.76	22.7	4.57	21.3	4.42	20.6	4.22	20.0	4.09	18.6	3.85	
15	13.7	24.0	4.49	22.7	4.31	21.3	4.16	20.6	3.98	20.0	3.86	18.6	3.63	
60	-19.8	-20	20.6	12.43	19.5	11.91	18.3	11.23	17.7	10.59	17.1	10.00	16.0	9.42
	-18.8	-19	20.6	12.16	19.5	11.66	18.3	10.99	17.7	10.37	17.1	9.79	16.0	9.22
	-16.7	-17	20.6	11.61	19.5	11.12	18.3	10.48	17.7	9.90	17.1	9.35	16.0	8.81
	-13.7	-15	20.6	10.82	19.5	10.35	18.3	9.76	17.7	9.23	17.1	8.73	16.0	8.21
	-11.8	-13	20.6	10.32	19.5	9.86	18.3	9.31	17.7	8.80	17.1	8.33	16.0	7.84
	-9.8	-11	20.6	9.79	19.5	9.34	18.3	8.83	17.7	8.36	17.1	7.92	16.0	7.44
	-9.5	-10	20.6	9.71	19.5	9.27	18.3	8.75	17.7	8.29	17.1	7.85	16.0	7.38
	-8.5	-9.1	20.6	9.45	19.5	9.01	18.3	8.51	17.7	8.07	17.1	7.65	16.0	7.18
	-7	-7.6	20.6	9.06	19.5	8.63	18.3	8.15	17.7	7.73	17.1	7.33	16.0	6.89
	-5	-5.6	20.6	8.53	19.5	8.11	18.3	7.67	17.7	7.29	17.1	6.92	16.0	6.49
	-3	-3.7	20.6	8.00	19.5	7.60	18.3	7.19	17.7	6.84	17.1	6.50	16.0	6.09
	0	-0.7	20.6	7.21	19.5	6.83	18.3	6.47	17.7	6.17	17.1	5.88	16.0	5.50
	3	2.2	20.6	6.42	19.5	6.06	18.3	5.76	17.7	5.50	17.1	5.25	16.0	4.90
	5	4.1	20.6	5.90	19.5	5.54	18.3	5.28	17.7	5.05	17.1	4.84	16.0	4.51
	7	6	20.6	5.37	19.5	5.03	18.3	4.80	17.7	4.61	17.1	4.42	16.0	4.11
	9	7.9	20.6	4.79	19.5	4.49	18.3	4.28	17.7	4.11	17.1	3.94	16.0	3.67
11	9.8	20.6	4.47	19.5	4.19	18.3	3.99	17.7	3.84	17.1	3.68	16.0	3.42	
13	11.8	20.6	4.19	19.5	3.93	18.3	3.74	17.7	3.60	17.1	3.45	16.0	3.21	
15	13.7	20.6	3.96	19.5	3.71	18.3	3.54	17.7	3.40	17.1	3.26	16.0	3.03	
50	-19.8	-20	17.2	10.35	16.2	9.74	15.2	9.18	14.7	8.65	14.3	8.17	13.3	7.70
	-18.8	-19	17.2	10.13	16.2	9.53	15.2	8.98	14.7	8.47	14.3	8.00	13.3	7.54
	-16.7	-17	17.2	9.66	16.2	9.08	15.2	8.57	14.7	8.08	14.3	7.64	13.3	7.20
	-13.7	-15	17.2	8.98	16.2	8.45	15.2	7.98	14.7	7.53	14.3	7.13	13.3	6.71
	-11.8	-13	17.2	8.56	16.2	8.04	15.2	7.61	14.7	7.18	14.3	6.80	13.3	6.40
	-9.8	-11	17.2	8.11	16.2	7.62	15.2	7.21	14.7	6.81	14.3	6.46	13.3	6.08
	-9.5	-10	17.2	8.04	16.2	7.56	15.2	7.15	14.7	6.75	14.3	6.41	13.3	6.03
	-8.5	-9.1	17.2	7.81	16.2	7.34	15.2	6.96	14.7	6.57	14.3	6.24	13.3	5.87
	-7	-7.6	17.2	7.48	16.2	7.03	15.2	6.66	14.7	6.29	14.3	5.98	13.3	5.62
	-5	-5.6	17.2	7.03	16.2	6.60	15.2	6.27	14.7	5.92	14.3	5.64	13.3	5.30
	-3	-3.7	17.2	6.58	16.2	6.18	15.2	5.87	14.7	5.56	14.3	5.30	13.3	4.98
	0	-0.7	17.2	5.90	16.2	5.54	15.2	5.28	14.7	5.00	14.3	4.79	13.3	4.49
	3	2.2	17.2	5.23	16.2	4.90	15.2	4.69	14.7	4.45	14.3	4.28	13.3	4.00
	5	4.1	17.2	4.78	16.2	4.48	15.2	4.30	14.7	4.08	14.3	3.94	13.3	3.68
	7	6	17.2	4.33	16.2	4.06	15.2	3.91	14.7	3.71	14.3	3.60	13.3	3.35
	9	7.9	17.2	3.91	16.2	3.66	15.2	3.53	14.7	3.35	14.3	3.25	13.3	3.03
11	9.8	17.2	3.66	16.2	3.43	15.2	3.30	14.7	3.14	14.3	3.04	13.3	2.83	
13	11.8	17.2	3.44	16.2	3.22	15.2	3.10	14.7	2.94	14.3	2.85	13.3	2.66	
15	13.7	17.2	3.25	16.2	3.04	15.2	2.93	14.7	2.79	14.3	2.70	13.3	2.52	

Note

1. TC: Total Capacity(kW), PI : Power Input(kW, Comp. + Outdoor fan motor)
2. Capacity tables show the average value of conditions which may occur.

6. Capacity Tables

◆ ARUN120LSS0

Combination (%)	Outdoor air temp		Indoor air temp. °C DB											
			16		18		20		21		22		24	
	°C DB	°C WB	TC	PI	TC	PI	TC	PI	TC	PI	TC	PI	TC	PI
130	-19.8	-20	30.4	20.66	30.4	20.86	30.2	21.04	30.2	21.31	30.2	21.56	29.5	21.97
	-18.8	-19	30.9	20.79	30.9	21.00	30.7	21.17	30.7	21.44	30.7	21.70	30.0	22.10
	-16.7	-17	32.0	21.08	32.0	21.28	31.8	21.46	31.8	21.73	31.8	21.98	31.0	22.39
	-13.7	-15	33.6	21.48	33.6	21.68	33.4	21.86	33.4	22.13	33.4	22.39	32.5	21.21
	-11.8	-13	34.6	21.74	34.6	21.94	34.3	22.12	34.3	22.39	34.3	21.57	33.5	20.46
	-9.8	-11	35.6	22.01	35.6	22.21	35.3	22.39	35.3	21.48	35.3	20.71	34.5	19.68
	-9.5	-10	35.8	22.05	35.8	22.25	35.6	22.24	35.6	21.35	35.5	20.58	34.7	19.56
	-8.5	-9.1	36.5	22.18	36.5	22.39	36.3	21.76	36.3	20.90	36.0	20.15	35.2	19.16
	-7	-7.6	37.6	22.39	37.6	21.65	37.3	21.04	37.3	20.22	37.3	19.50	35.9	18.58
	-5	-5.6	39.0	21.36	39.0	20.66	38.7	20.08	38.7	19.31	38.7	18.64	36.9	17.79
	-3	-3.7	40.4	20.34	40.4	19.67	40.1	19.12	40.1	18.41	40.1	17.78	38.0	17.00
	0	-0.7	42.5	18.81	42.5	18.19	42.3	17.67	42.3	17.06	42.3	16.49	39.5	15.83
	3	2.2	44.6	17.27	44.6	16.71	44.4	16.23	44.4	15.70	44.4	15.20	41.0	14.65
	5	4.1	46.1	16.25	46.1	15.72	45.8	15.27	45.8	14.80	44.5	14.34	41.4	13.86
	7	6	47.4	15.23	47.4	14.74	47.2	14.31	46.1	13.89	44.5	13.48	41.4	13.08
	9	7.9	47.4	14.35	47.4	13.88	47.3	13.48	46.1	13.09	44.5	12.70	41.4	12.32
11	9.8	47.4	13.58	47.4	13.14	47.3	12.76	46.1	12.39	44.5	12.02	41.4	11.66	
13	11.8	47.4	12.77	47.4	12.35	47.3	12.00	46.1	11.65	44.5	11.30	41.4	10.96	
15	13.7	47.4	11.91	47.4	11.53	47.3	11.20	46.1	10.87	44.5	10.55	41.4	10.23	
120	-19.8	-20	30.2	20.86	30.2	21.04	30.0	21.31	30.0	21.56	30.0	21.97	29.2	22.25
	-18.8	-19	30.7	21.00	30.7	21.17	30.5	21.44	30.5	21.70	30.5	22.10	29.7	22.39
	-16.7	-17	31.8	21.28	31.8	21.46	31.6	21.73	31.6	21.98	31.6	22.39	30.8	21.63
	-13.7	-15	33.4	21.68	33.4	21.86	33.2	22.13	33.2	22.39	33.2	21.24	32.3	20.55
	-11.8	-13	34.3	21.94	34.3	22.12	34.1	22.39	34.1	21.57	34.1	20.51	33.3	19.86
	-9.8	-11	35.3	22.21	35.3	22.39	35.1	21.46	35.1	20.70	35.1	19.74	34.3	19.14
	-9.5	-10	35.5	22.25	35.5	22.24	35.3	21.32	35.3	20.57	35.3	19.63	34.4	19.03
	-8.5	-9.1	36.2	22.39	36.2	21.74	36.0	20.86	36.0	20.14	35.8	19.25	34.9	18.67
	-7	-7.6	37.3	21.61	37.3	20.98	37.1	20.17	37.1	19.49	36.6	18.67	35.7	18.13
	-5	-5.6	38.7	20.57	38.7	19.98	38.5	19.24	38.5	18.62	38.5	17.91	36.7	17.40
	-3	-3.7	40.1	19.54	40.1	18.98	39.9	18.32	39.9	17.76	39.9	17.14	37.7	16.68
	0	-0.7	42.2	17.99	42.2	17.48	42.0	16.93	42.0	16.46	41.8	15.99	38.9	15.60
	3	2.2	44.3	16.43	44.3	15.98	44.1	15.55	43.2	15.17	41.8	14.84	38.9	14.52
	5	4.1	45.7	15.40	45.7	14.97	44.7	14.62	43.2	14.30	41.9	14.07	38.9	13.79
	7	6	47.1	14.36	46.6	13.97	44.7	13.70	43.2	13.44	41.9	13.31	38.9	13.07
	9	7.9	47.1	13.53	46.6	13.16	44.7	12.90	43.2	12.65	41.9	12.53	38.9	12.31
11	9.8	47.1	12.80	46.6	12.45	44.7	12.20	43.2	11.97	41.9	11.86	38.9	11.65	
13	11.8	47.1	12.03	46.6	11.70	44.7	11.47	43.2	11.25	41.9	11.14	38.9	10.95	
15	13.7	47.1	11.22	46.6	10.92	44.7	10.70	43.2	10.50	41.9	10.40	38.9	10.21	
110	-19.8	-20	30.0	21.04	30.0	21.31	29.8	21.56	29.8	21.97	29.8	22.25	29.1	22.39
	-18.8	-19	30.5	21.17	30.5	21.44	30.4	21.70	30.4	22.10	30.4	22.39	29.6	22.01
	-16.7	-17	31.6	21.46	31.6	21.73	31.4	21.98	31.4	22.39	31.4	21.59	30.6	21.21
	-13.7	-15	33.2	21.86	33.2	22.13	33.0	22.39	33.0	21.17	33.0	20.45	33.0	20.07
	-11.8	-13	34.1	22.12	34.1	22.39	33.9	21.52	33.9	20.40	33.9	19.73	33.9	19.35
	-9.8	-11	35.1	22.39	35.1	21.40	34.9	20.60	34.9	19.59	34.9	18.97	34.2	18.59
	-9.5	-10	35.3	22.22	35.3	21.25	35.1	20.47	35.1	19.47	35.1	18.86	34.7	18.48
	-8.5	-9.1	36.0	21.68	36.0	20.75	35.8	20.01	35.8	19.06	35.8	18.48	35.0	18.10
	-7	-7.6	37.1	20.87	37.1	20.01	36.9	19.32	36.9	18.45	36.9	17.91	35.0	17.53
	-5	-5.6	38.5	19.78	38.5	19.02	38.2	18.41	38.2	17.64	37.5	17.16	35.0	16.77
	-3	-3.7	39.9	18.70	39.9	18.03	39.6	17.50	38.8	16.83	37.5	16.40	35.0	16.01
	0	-0.7	42.0	17.07	42.0	16.54	40.1	16.13	38.8	15.61	37.5	15.26	35.0	14.87
	3	2.2	44.1	15.44	42.8	15.06	40.1	14.76	38.8	14.39	37.5	14.12	35.0	13.73
	5	4.1	45.2	14.36	42.8	14.06	40.1	13.84	38.8	13.58	37.5	13.36	35.0	12.98
	7	6	45.2	13.27	42.8	13.07	40.1	12.93	38.8	12.77	37.5	12.61	35.0	12.22
	9	7.9	45.2	12.46	42.8	12.27	40.1	12.13	38.8	11.99	37.5	11.83	35.0	11.47
11	9.8	45.2	11.74	42.8	11.56	40.1	11.43	38.8	11.29	37.5	11.15	35.0	10.80	
13	11.8	45.2	10.98	42.8	10.82	40.1	10.69	38.8	10.56	37.5	10.43	35.0	10.11	
15	13.7	45.2	10.19	42.8	10.03	40.1	9.92	38.8	9.80	37.5	9.67	35.0	9.38	

6. Capacity Tables

Combination (%)	Outdoor air temp		Indoor air temp. °C DB											
			16		18		20		21		22		24	
	°C DB	°C WB	TC	PI	TC	PI	TC	PI	TC	PI	TC	PI	TC	PI
100	-19.8	-20	29.9	21.60	29.9	21.76	29.7	21.85	29.7	22.14	29.7	22.35	29.0	22.39
	-18.8	-19	30.4	21.68	30.2	21.84	30.2	21.99	30.2	22.22	30.2	22.39	29.5	21.95
	-16.7	-17	31.3	21.85	31.3	22.00	31.3	22.27	31.1	22.39	31.1	21.48	30.3	21.04
	-13.7	-15	33.0	22.08	33.0	22.24	32.8	22.39	32.8	21.03	32.8	20.17	32.0	19.74
	-11.8	-13	33.9	22.23	33.8	22.39	33.8	21.45	33.8	20.18	33.8	19.35	32.0	18.92
	-9.8	-11	34.9	22.39	34.9	21.33	34.8	20.47	34.8	19.28	34.4	18.48	32.0	18.05
	-9.5	-10	35.1	22.22	35.1	21.17	35.0	20.33	35.0	19.14	34.4	18.35	32.0	17.92
	-8.5	-9.1	35.8	21.65	35.8	20.64	35.7	19.84	35.5	18.69	34.4	17.92	32.0	17.49
	-7	-7.6	37.5	20.80	37.3	19.85	36.7	19.10	35.5	18.01	34.4	17.27	32.0	16.84
	-5	-5.6	39.1	19.66	38.7	18.79	36.7	18.12	35.5	17.11	34.4	16.40	32.0	15.97
	-3	-3.7	40.3	18.53	39.0	17.73	36.7	17.14	35.5	16.21	34.4	15.53	32.0	15.10
	0	-0.7	41.4	16.82	39.0	16.15	36.7	15.66	35.5	14.86	34.4	14.23	32.0	13.80
	3	2.2	41.4	15.12	39.0	14.56	36.7	14.19	35.5	13.50	34.4	12.93	32.0	12.50
	5	4.1	41.4	13.99	39.0	13.50	36.7	13.21	35.5	12.60	34.4	12.06	32.0	11.63
	7	6	41.4	12.85	39.0	12.45	36.7	12.23	35.5	11.70	34.4	11.19	32.0	10.77
	9	7.9	41.4	11.75	39.0	11.38	36.7	11.18	35.5	10.70	34.4	10.24	32.0	9.85
11	9.8	41.4	10.73	39.0	10.39	36.7	10.21	35.5	9.77	34.4	9.35	32.0	8.99	
13	11.8	41.4	9.66	39.0	9.36	36.7	9.20	35.5	8.80	34.4	8.42	32.0	8.10	
15	13.7	41.4	8.55	39.0	8.28	36.7	8.13	35.5	7.78	34.4	7.45	32.0	7.16	
90	-19.8	-20	29.8	20.29	29.8	20.70	29.6	20.98	29.6	21.11	29.6	20.37	28.8	19.33
	-18.8	-19	30.4	20.43	30.2	20.83	30.1	21.11	30.1	20.73	30.1	20.00	29.3	18.98
	-16.7	-17	31.3	20.71	31.3	21.11	31.2	20.30	31.2	19.91	31.2	19.21	29.3	18.23
	-13.7	-15	33.0	21.11	33.0	19.88	32.7	19.13	32.5	18.74	31.5	18.09	29.3	17.16
	-11.8	-13	33.9	20.25	33.8	19.10	33.6	18.39	32.5	18.00	31.5	17.39	29.3	16.48
	-9.8	-11	34.9	19.35	34.9	18.28	33.6	17.61	32.5	17.23	31.5	16.64	29.3	15.77
	-9.5	-10	35.1	19.21	35.1	18.16	33.6	17.50	32.5	17.11	31.5	16.53	29.3	15.66
	-8.5	-9.1	35.8	18.76	35.6	17.75	33.6	17.11	32.5	16.72	31.5	16.16	29.3	15.31
	-7	-7.6	37.5	18.08	35.7	17.13	33.6	16.52	32.5	16.14	31.5	15.60	29.3	14.77
	-5	-5.6	37.9	17.18	35.7	16.31	33.6	15.74	32.5	15.36	31.5	14.85	29.3	14.06
	-3	-3.7	37.9	16.27	35.7	15.49	33.6	14.97	32.5	14.58	31.5	14.11	29.3	13.35
	0	-0.7	37.9	14.91	35.7	14.26	33.6	13.80	32.5	13.42	31.5	12.99	29.3	12.28
	3	2.2	37.9	13.55	35.7	13.02	33.6	12.63	32.5	12.25	31.5	11.87	29.3	11.21
	5	4.1	37.9	12.65	35.7	12.20	33.6	11.85	32.5	11.48	31.5	11.13	29.3	10.50
	7	6	37.9	11.74	35.7	11.38	33.6	11.08	32.5	10.70	31.5	10.38	29.3	9.79
	9	7.9	37.9	10.92	35.7	10.58	33.6	10.30	32.5	9.95	31.5	9.65	29.3	9.10
11	9.8	37.9	10.09	35.7	9.78	33.6	9.52	32.5	9.20	31.5	8.92	29.3	8.41	
13	11.8	37.9	9.27	35.7	8.98	33.6	8.74	32.5	8.44	31.5	8.19	29.3	7.73	
15	13.7	37.9	8.44	35.7	8.18	33.6	7.96	32.5	7.69	31.5	7.46	29.3	7.04	
80	-19.8	-20	29.5	17.90	29.5	18.30	29.5	18.72	29.1	18.05	28.1	17.15	26.1	16.30
	-18.8	-19	30.0	18.03	30.0	18.72	30.0	18.37	29.1	17.71	28.1	16.84	26.1	16.00
	-16.7	-17	30.0	18.72	30.0	17.99	30.0	17.65	29.1	17.01	28.1	16.18	26.1	15.38
	-13.7	-15	30.0	17.62	30.0	16.94	30.0	16.61	29.1	16.00	28.1	15.24	26.1	14.49
	-11.8	-13	31.0	16.92	30.2	16.28	30.0	15.95	29.1	15.36	28.1	14.64	26.1	13.92
	-9.8	-11	32.2	16.18	31.3	15.58	30.0	15.25	29.1	14.68	28.1	14.01	26.1	13.33
	-9.5	-10	32.4	16.07	31.4	15.47	30.0	15.15	29.1	14.58	28.1	13.92	26.1	13.24
	-8.5	-9.1	33.0	15.70	32.0	15.12	30.0	14.80	29.1	14.25	28.1	13.60	26.1	12.94
	-7	-7.6	33.9	15.15	32.0	14.60	30.0	14.28	29.1	13.74	28.1	13.13	26.1	12.50
	-5	-5.6	33.9	14.42	32.0	13.90	30.0	13.59	29.1	13.07	28.1	12.50	26.1	11.90
	-3	-3.7	33.9	13.68	32.0	13.20	30.0	12.89	29.1	12.40	28.1	11.88	26.1	11.31
	0	-0.7	33.9	12.58	32.0	12.16	30.0	11.85	29.1	11.39	28.1	10.93	26.1	10.42
	3	2.2	33.9	11.47	32.0	11.11	30.0	10.81	29.1	10.38	28.1	9.99	26.1	9.53
	5	4.1	33.9	10.74	32.0	10.41	30.0	10.12	29.1	9.71	28.1	9.36	26.1	8.93
	7	6	33.9	10.00	32.0	9.71	30.0	9.42	29.1	9.03	28.1	8.74	26.1	8.34
	9	7.9	33.9	9.39	32.0	9.12	30.0	8.85	29.1	8.48	28.1	8.20	26.1	7.83
11	9.8	33.9	8.72	32.0	8.46	30.0	8.21	29.1	7.87	28.1	7.61	26.1	7.27	
13	11.8	33.9	8.14	32.0	7.90	30.0	7.67	29.1	7.35	28.1	7.11	26.1	6.79	
15	13.7	33.9	7.66	32.0	7.44	30.0	7.22	29.1	6.92	28.1	6.69	26.1	6.39	

6. Capacity Tables

Combination (%)	Outdoor air temp		Indoor air temp. °C DB											
			16		18		20		21		22		24	
	°C DB	°C WB	TC	PI	TC	PI	TC	PI	TC	PI	TC	PI	TC	PI
70	-19.8	-20	27.5	18.15	27.2	18.28	25.6	17.58	24.7	16.62	24.0	15.74	22.4	14.89
	-18.8	-19	28.3	18.28	27.2	17.91	25.6	17.22	24.7	16.29	24.0	15.44	22.4	14.60
	-16.7	-17	28.8	17.50	27.2	17.14	25.6	16.48	24.7	15.59	24.0	14.79	22.4	13.99
	-13.7	-15	28.8	16.39	27.2	16.02	25.6	15.41	24.7	14.59	24.0	13.86	22.4	13.11
	-11.8	-13	28.8	15.69	27.2	15.32	25.6	14.74	24.7	13.96	24.0	13.28	22.4	12.55
	-9.8	-11	28.8	14.94	27.2	14.58	25.6	14.03	24.7	13.30	24.0	12.66	22.4	11.96
	-9.5	-10	28.8	14.83	27.2	14.47	25.6	13.93	24.7	13.20	24.0	12.57	22.4	11.87
	-8.5	-9.1	28.8	14.46	27.2	14.10	25.6	13.57	24.7	12.87	24.0	12.26	22.4	11.58
	-7	-7.6	28.8	13.90	27.2	13.54	25.6	13.04	24.7	12.37	24.0	11.80	22.4	11.14
	-5	-5.6	28.8	13.16	27.2	12.80	25.6	12.33	24.7	11.70	24.0	11.18	22.4	10.55
	-3	-3.7	28.8	12.42	27.2	12.06	25.6	11.62	24.7	11.04	24.0	10.56	22.4	9.97
	0	-0.7	28.8	11.31	27.2	10.95	25.6	10.56	24.7	10.04	24.0	9.64	22.4	9.09
	3	2.2	28.8	10.19	27.2	9.84	25.6	9.50	24.7	9.04	24.0	8.71	22.4	8.21
	5	4.1	28.8	9.45	27.2	9.10	25.6	8.79	24.7	8.38	24.0	8.10	22.4	7.62
	7	6	28.8	8.71	27.2	8.36	25.6	8.08	24.7	7.71	24.0	7.48	22.4	7.03
	9	7.9	28.8	7.86	27.2	7.55	25.6	7.30	24.7	6.97	24.0	6.76	22.4	6.35
11	9.8	28.8	7.32	27.2	7.03	25.6	6.79	24.7	6.49	24.0	6.29	22.4	5.91	
13	11.8	28.8	6.85	27.2	6.58	25.6	6.36	24.7	6.07	24.0	5.88	22.4	5.53	
15	13.7	28.8	6.46	27.2	6.20	25.6	5.99	24.7	5.72	24.0	5.55	22.4	5.22	
60	-19.8	-20	24.7	17.88	23.4	17.14	21.9	16.15	21.2	15.24	20.5	14.38	19.1	13.56
	-18.8	-19	24.7	17.50	23.4	16.77	21.9	15.81	21.2	14.92	20.5	14.08	19.1	13.27
	-16.7	-17	24.7	16.70	23.4	15.99	21.9	15.08	21.2	14.24	20.5	13.46	19.1	12.67
	-13.7	-15	24.7	15.57	23.4	14.89	21.9	14.05	21.2	13.28	20.5	12.56	19.1	11.82
	-11.8	-13	24.7	14.85	23.4	14.18	21.9	13.39	21.2	12.67	20.5	11.99	19.1	11.28
	-9.8	-11	24.7	14.09	23.4	13.44	21.9	12.70	21.2	12.03	20.5	11.39	19.1	10.70
	-9.5	-10	24.7	13.98	23.4	13.33	21.9	12.60	21.2	11.93	20.5	11.30	19.1	10.62
	-8.5	-9.1	24.7	13.60	23.4	12.96	21.9	12.25	21.2	11.61	20.5	11.00	19.1	10.33
	-7	-7.6	24.7	13.03	23.4	12.41	21.9	11.73	21.2	11.13	20.5	10.55	19.1	9.91
	-5	-5.6	24.7	12.27	23.4	11.67	21.9	11.04	21.2	10.48	20.5	9.95	19.1	9.34
	-3	-3.7	24.7	11.51	23.4	10.93	21.9	10.35	21.2	9.84	20.5	9.35	19.1	8.77
	0	-0.7	24.7	10.38	23.4	9.82	21.9	9.32	21.2	8.88	20.5	8.46	19.1	7.91
	3	2.2	24.7	9.24	23.4	8.71	21.9	8.28	21.2	7.92	20.5	7.56	19.1	7.06
	5	4.1	24.7	8.48	23.4	7.98	21.9	7.59	21.2	7.27	20.5	6.96	19.1	6.48
	7	6	24.7	7.73	23.4	7.24	21.9	6.90	21.2	6.63	20.5	6.36	19.1	5.91
	9	7.9	24.7	6.89	23.4	6.46	21.9	6.16	21.2	5.92	20.5	5.68	19.1	5.28
11	9.8	24.7	6.44	23.4	6.03	21.9	5.75	21.2	5.52	20.5	5.30	19.1	4.93	
13	11.8	24.7	6.03	23.4	5.65	21.9	5.38	21.2	5.17	20.5	4.96	19.1	4.62	
15	13.7	24.7	5.70	23.4	5.34	21.9	5.09	21.2	4.89	20.5	4.69	19.1	4.36	
50	-19.8	-20	20.6	14.90	19.4	14.02	18.3	13.21	17.7	12.45	17.1	11.75	15.9	11.08
	-18.8	-19	20.6	14.57	19.4	13.71	18.3	12.93	17.7	12.18	17.1	11.51	15.9	10.84
	-16.7	-17	20.6	13.89	19.4	13.07	18.3	12.33	17.7	11.63	17.1	10.99	15.9	10.35
	-13.7	-15	20.6	12.92	19.4	12.15	18.3	11.48	17.7	10.83	17.1	10.26	15.9	9.66
	-11.8	-13	20.6	12.31	19.4	11.57	18.3	10.94	17.7	10.33	17.1	9.79	15.9	9.21
	-9.8	-11	20.6	11.66	19.4	10.96	18.3	10.38	17.7	9.80	17.1	9.30	15.9	8.75
	-9.5	-10	20.6	11.57	19.4	10.87	18.3	10.29	17.7	9.72	17.1	9.22	15.9	8.68
	-8.5	-9.1	20.6	11.24	19.4	10.57	18.3	10.01	17.7	9.45	17.1	8.98	15.9	8.44
	-7	-7.6	20.6	10.76	19.4	10.11	18.3	9.59	17.7	9.05	17.1	8.61	15.9	8.09
	-5	-5.6	20.6	10.11	19.4	9.50	18.3	9.02	17.7	8.52	17.1	8.12	15.9	7.63
	-3	-3.7	20.6	9.46	19.4	8.89	18.3	8.45	17.7	7.99	17.1	7.63	15.9	7.16
	0	-0.7	20.6	8.49	19.4	7.97	18.3	7.60	17.7	7.20	17.1	6.89	15.9	6.46
	3	2.2	20.6	7.53	19.4	7.06	18.3	6.75	17.7	6.40	17.1	6.16	15.9	5.76
	5	4.1	20.6	6.88	19.4	6.45	18.3	6.19	17.7	5.87	17.1	5.67	15.9	5.29
	7	6	20.6	6.23	19.4	5.84	18.3	5.62	17.7	5.34	17.1	5.17	15.9	4.83
	9	7.9	20.6	5.63	19.4	5.27	18.3	5.08	17.7	4.82	17.1	4.67	15.9	4.36
11	9.8	20.6	5.27	19.4	4.93	18.3	4.75	17.7	4.51	17.1	4.37	15.9	4.08	
13	11.8	20.6	4.94	19.4	4.63	18.3	4.46	17.7	4.24	17.1	4.11	15.9	3.83	
15	13.7	20.6	4.68	19.4	4.38	18.3	4.22	17.7	4.01	17.1	3.88	15.9	3.62	

Note

1. TC: Total Capacity(kW), PI : Power Input(kW, Comp. + Outdoor fan motor)
2. Capacity tables show the average value of conditions which may occur.

7. Capacity Correction Factor

7.1 Capacity Correction Factor

7.1.1 Rate of change in Cooling capacity

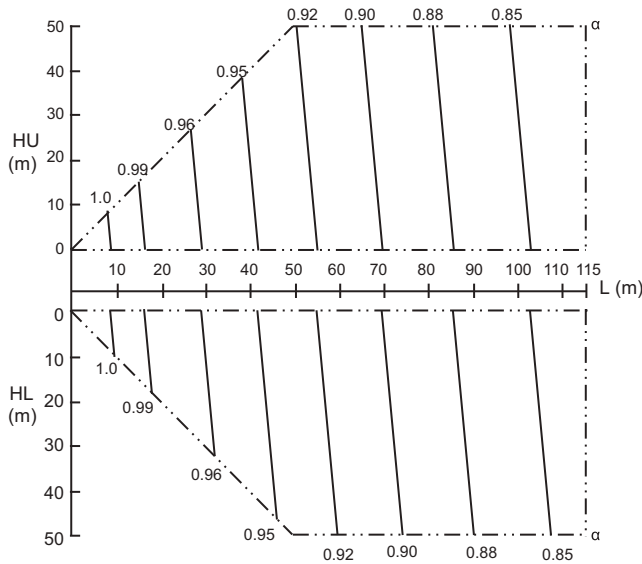

50	-	-	-	-	-	0.92	0.89	0.89	0.88	0.86	0.85	0.84	
40	-	-	-	-	0.94	0.93	0.92	0.89	0.89	0.88	0.86	0.85	0.84
30	-	-	-	-	0.94	0.93	0.92	0.90	0.89	0.88	0.86	0.85	0.84
20	-	-	-	-	0.97	0.94	0.93	0.92	0.90	0.89	0.88	0.86	0.85
10	-	0.99	0.98	0.97	0.94	0.93	0.92	0.90	0.89	0.88	0.86	0.86	0.85
7.5	1.00	0.99	0.98	0.97	0.94	0.93	0.92	0.90	0.89	0.88	0.86	0.86	0.85
0	1.00	0.99	0.98	0.97	0.94	0.93	0.93	0.90	0.89	0.89	0.86	0.86	0.85
0	7.5	10	20	30	40	50	60	70	80	90	100	110	115
0	1.00	0.99	0.98	0.97	0.94	0.93	0.93	0.90	0.89	0.89	0.86	0.86	0.85
7.5	1.00	0.99	0.98	0.97	0.94	0.93	0.93	0.90	0.89	0.89	0.86	0.86	0.85
10	-	0.99	0.98	0.98	0.94	0.93	0.93	0.90	0.89	0.89	0.86	0.86	0.85
20	-	-	-	0.98	0.94	0.94	0.93	0.90	0.89	0.89	0.87	0.86	0.85
30	-	-	-	-	0.95	0.94	0.93	0.90	0.9	0.89	0.87	0.86	0.85
40	-	-	-	-	0.95	0.94	0.93	0.90	0.9	0.89	0.87	0.86	0.85
50	-	-	-	-	-	0.93	0.91	0.9	0.89	0.87	0.86	0.86	0.85

7.1.2 Rate of change in Heating capacity

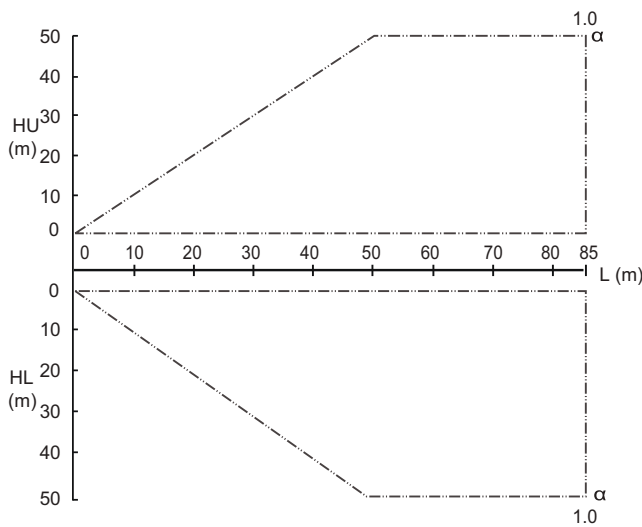

50	-	-	-	-	-	1.00	1.00	1.00	1.00	1.00	1.00	1.00	
40	-	-	-	-	1.00	1.00	1.00	1.00	1.00	1.00	1.00	1.00	1.00
30	-	-	-	1.00	1.00	1.00	1.00	1.00	1.00	1.00	1.00	1.00	1.00
20	-	-	1.00	1.00	1.00	1.00	1.00	1.00	1.00	1.00	1.00	1.00	1.00
10	-	1.00	1.00	1.00	1.00	1.00	1.00	1.00	1.00	1.00	1.00	1.00	1.00
7.5	1.00	1.00	1.00	1.00	1.00	1.00	1.00	1.00	1.00	1.00	1.00	1.00	1.00
0	1.00	1.00	1.00	1.00	1.00	1.00	1.00	1.00	1.00	1.00	1.00	1.00	1.00
0	7.5	10	20	30	40	50	60	70	80	85			
0	1.00	1.00	1.00	1.00	1.00	1.00	1.00	1.00	1.00	1.00	1.00	1.00	1.00
7.5	1.00	1.00	1.00	1.00	1.00	1.00	1.00	1.00	1.00	1.00	1.00	1.00	1.00
10	-	1.00	1.00	1.00	1.00	1.00	1.00	1.00	1.00	1.00	1.00	1.00	1.00
20	-	-	1.00	1.00	1.00	1.00	1.00	1.00	1.00	1.00	1.00	1.00	1.00
30	-	-	-	1.00	1.00	1.00	1.00	1.00	1.00	1.00	1.00	1.00	1.00
40	-	-	-	-	1.00	1.00	1.00	1.00	1.00	1.00	1.00	1.00	1.00
50	-	-	-	-	-	1.00	1.00	1.00	1.00	1.00	1.00	1.00	1.00

Symbols

HU : Level difference between indoor and outdoor units where outdoor unit in upper position (m)

HL : Level difference between indoor and outdoor units where outdoor unit in lower position (m)

L : Equivalent pipe length (m)

α : Capacity correction factor

7. Capacity Correction Factor

Note

1. These figures illustrate the rate of change in capacity of a standard indoor unit system at maximum load under standard conditions. (Moreover, under partial load conditions there is only a minor deviation from the rate of change in capacity shown in the above figures.)
2. With this outside unit, evaporating pressure constant control when cooling, and condensing pressure constant control when heating is carried out.
3. If heat insulation of piping is insufficient, heat loss will become larger and capacity will decrease.
4. Method of calculating cooling / heating capacity : maximum cooling / heating capacity of outside units = cooling / heating capacity of outside units obtained from capacity table X capacity correction factor due to piping length to the farthest indoor unit
5. Equivalent piping length for Y Branch and other pipes can be calculated with following table.

mm (inch)	Ø6.35 (1/4)	Ø9.52 (3/8)	Ø12.7 (1/2)	Ø15.8 8 (5/8)	Ø19.0 5 (3/4)	Ø22.2 (7/8)	Ø25.4 (1)	Ø28.58 (1-1/8)	Ø31.8 (1-1/4)	Ø34.9 (1-3/8)	Ø38.1 (1-1/2)	Ø41.3 (1-5/8)	Ø44.5 (1-3/4)	Ø53.98 (2-1/8)
Elbow (m)	0.16	0.18	0.2	0.25	0.35	0.4	0.45	0.5	0.55	0.6	0.65	0.7	0.75	0.85
Y Branch (m)	0.5													
Header (m)	1													
HR Unit* (m)	2.5													

* : HR unit is applicable only for Heat Recovery models.

6. When the equivalent length between outdoor unit and the farthest indoor unit is 90m or more, the diameter of main pipe must be increased. (Liquid and Gas pipes are increased.)
Refer to the table (Refrigerant pipe diameter from outdoor unit to first branch.) in the 'installation of outdoor units' part.
7. Read cooling / heating capacity rate of change in the above figures based on the following equivalent length. : overall equivalent length = (equivalent length of main pipe) X correction factor + (equivalent length after first branching)

Rate of change (object piping)	Correction factor	
	standard size	size increase
Cooling(Gas pipe)	1	0.5
Heating(Liquid pipe)	1	0.2

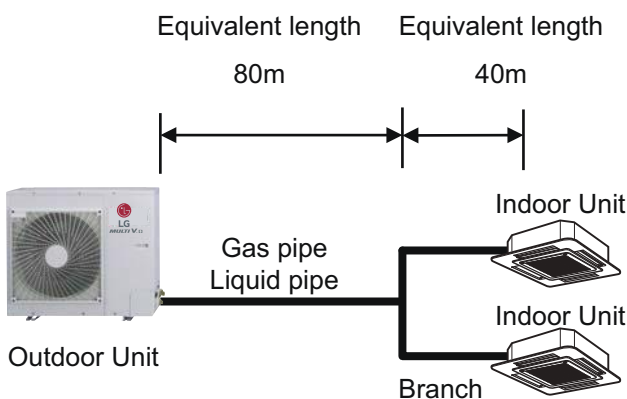

- (Cooling) Overall equivalent length = 80 m x 0.5 + 40 m = 80 m
- (Heating) Overall equivalent length = 80 m x 0.2 + 40 m = 56 m

The rate of change in Cooling capacity when HU = 0m is thus approximately 0.85
Heating capacity when HU = 0m is thus approximately 1.00

7. Capacity Correction Factor

7.2 Defrosting Correction Factor for Heating Operation

The capacity table does not consider reduction in capacity when frost has accumulated or during defrosting. The capacity values considered these factors, in other words the integrated heating capacity values, can be obtained as follows:

[Formula]

- Integrated Heating capacity = A
- Value given in table of capacity characteristics = B
- Integrated correction factor for frost accumulation = C
- $A=B \times C$

[Correction factor for finding integrated Heating capacity]

Inlet Port Temperature of Heat Exchange (°C, RH 85%)	-7	-5	-3	0	3	5	7
Integrated Correction Factor for Frost Accumulation (Normal Defrost Operation)	0.98	0.95	0.93	0.86	0.93	0.96	1.0
Integrated Correction Factor for Frost Accumulation (Partial Defrost Operation)	0.98	0.95	0.93	0.91	0.95	0.97	1.0

◆ Normal Defrost Operation

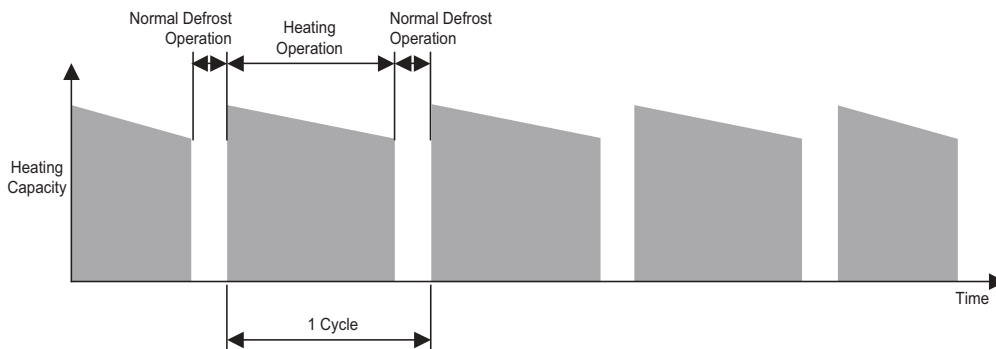

◆ Partial Defrost Operation

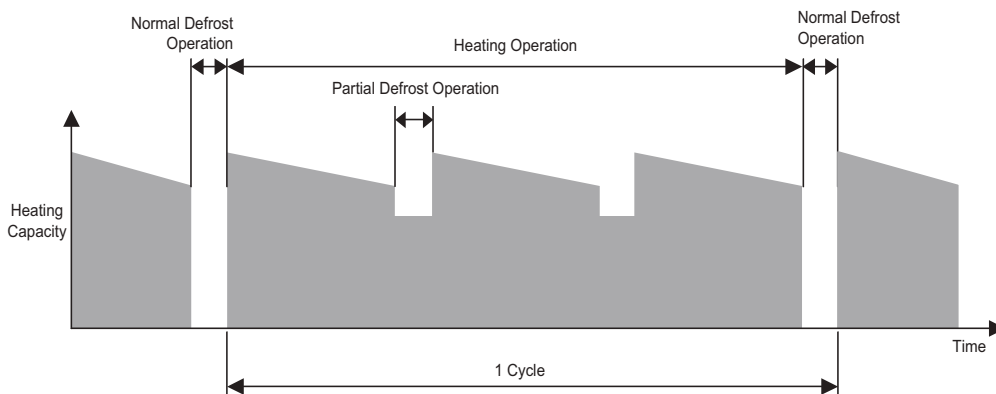

Please note that there will be temporary reduction in capacity when snow piles up on the outside surface of the heat exchanger. Of course, it will be different in degree depending on a number of other factors, for example, the outdoor temperature(°CDB), the relative humidity(RH) and the frosting amount.

8. Operation Limits

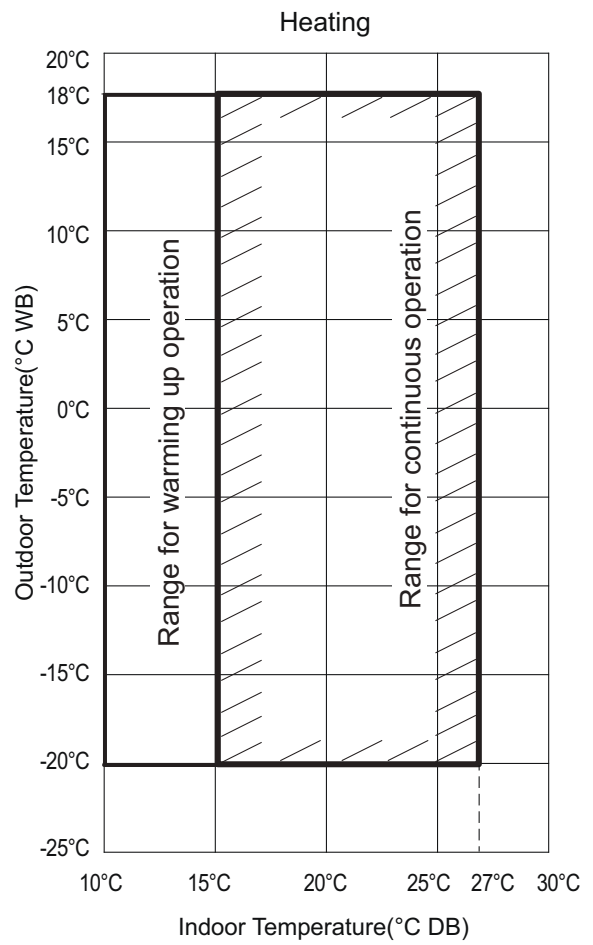
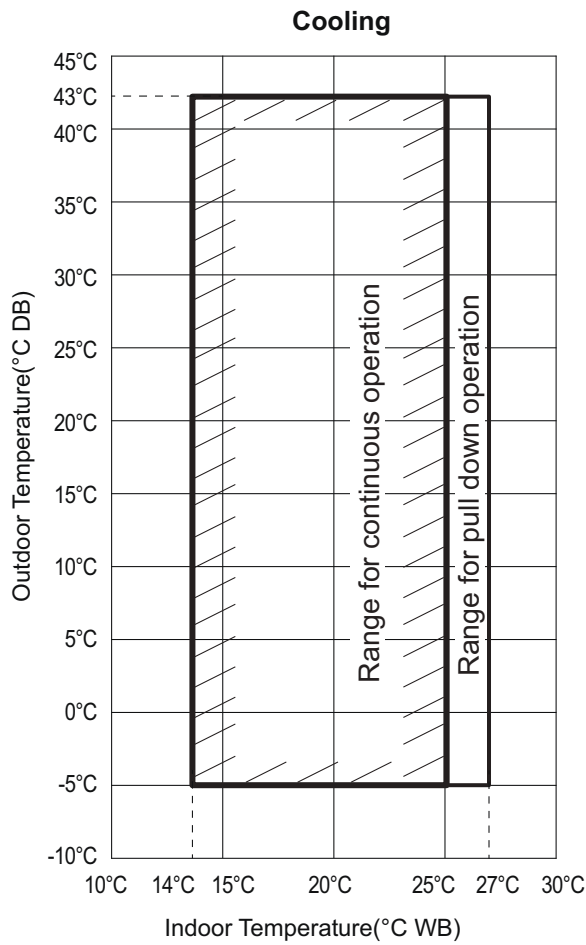

Note

These figures assume the following operating conditions:

Equivalent piping length:7.5m

Level difference:0m

9. Piping Diagrams

9.1 4 HP U4 Chassis (1Ø)

■ Cooling Operation

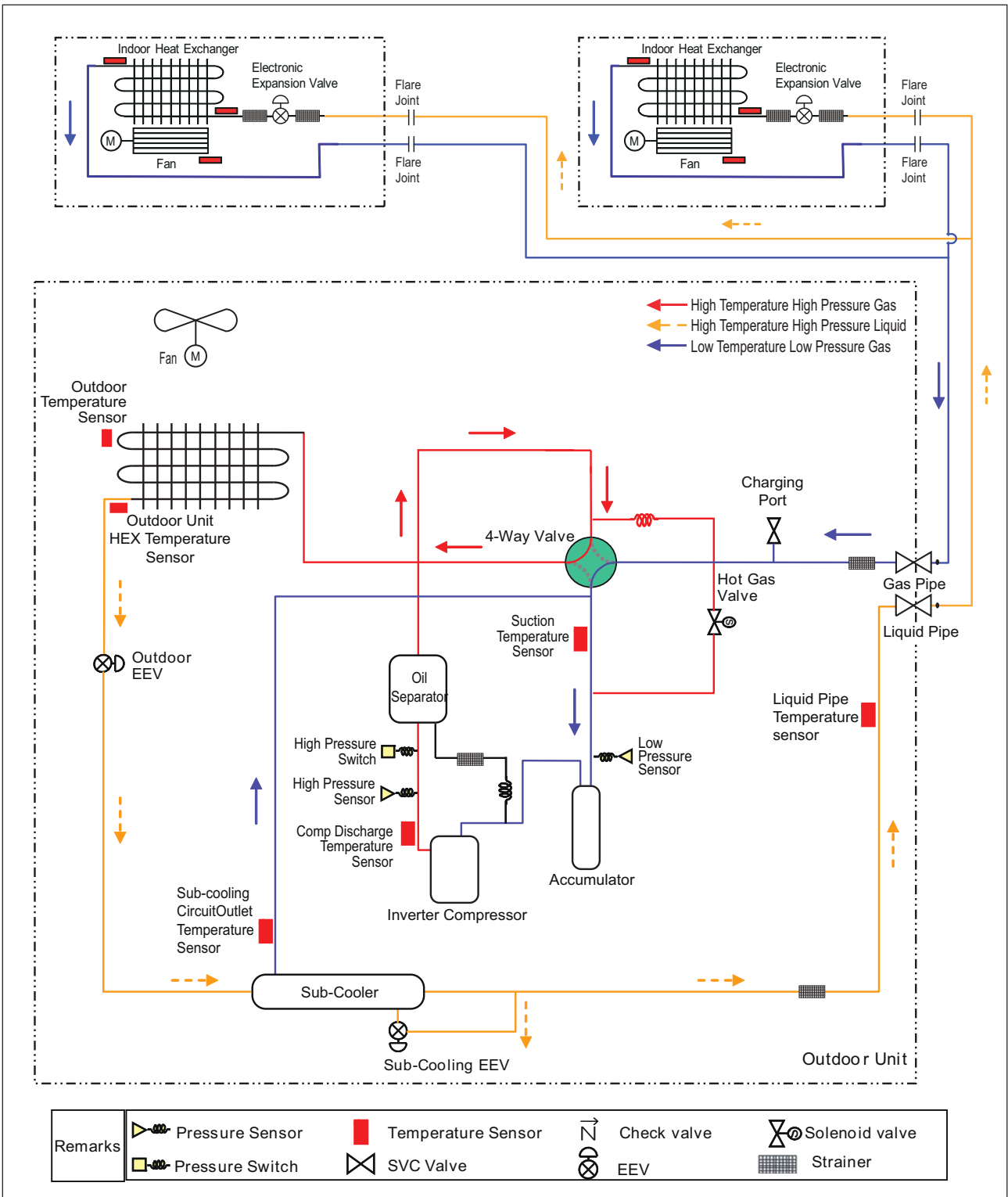

9. Piping Diagrams

■ Heating Operation

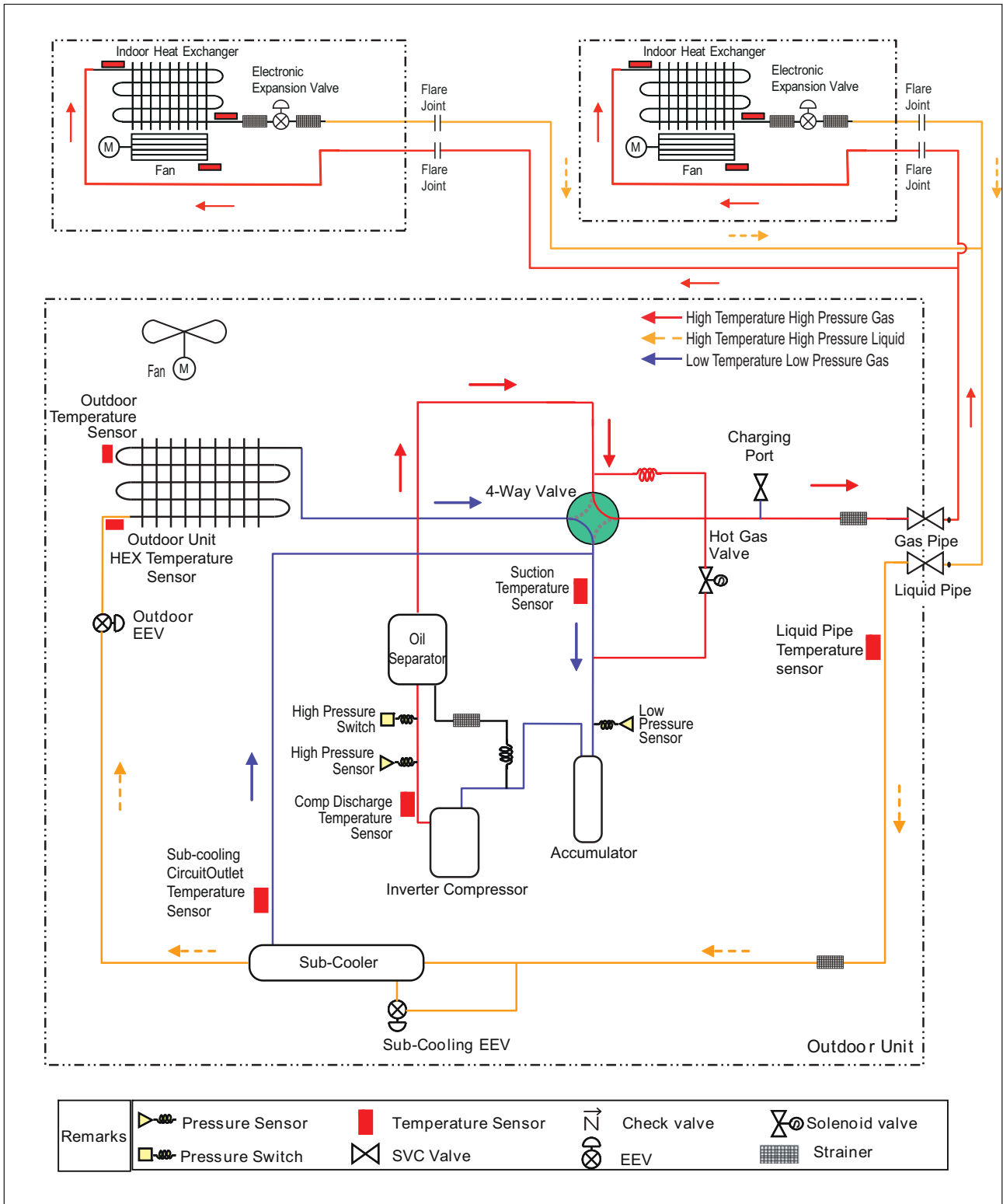

9. Piping Diagrams

Oil Return / Defrost Operation

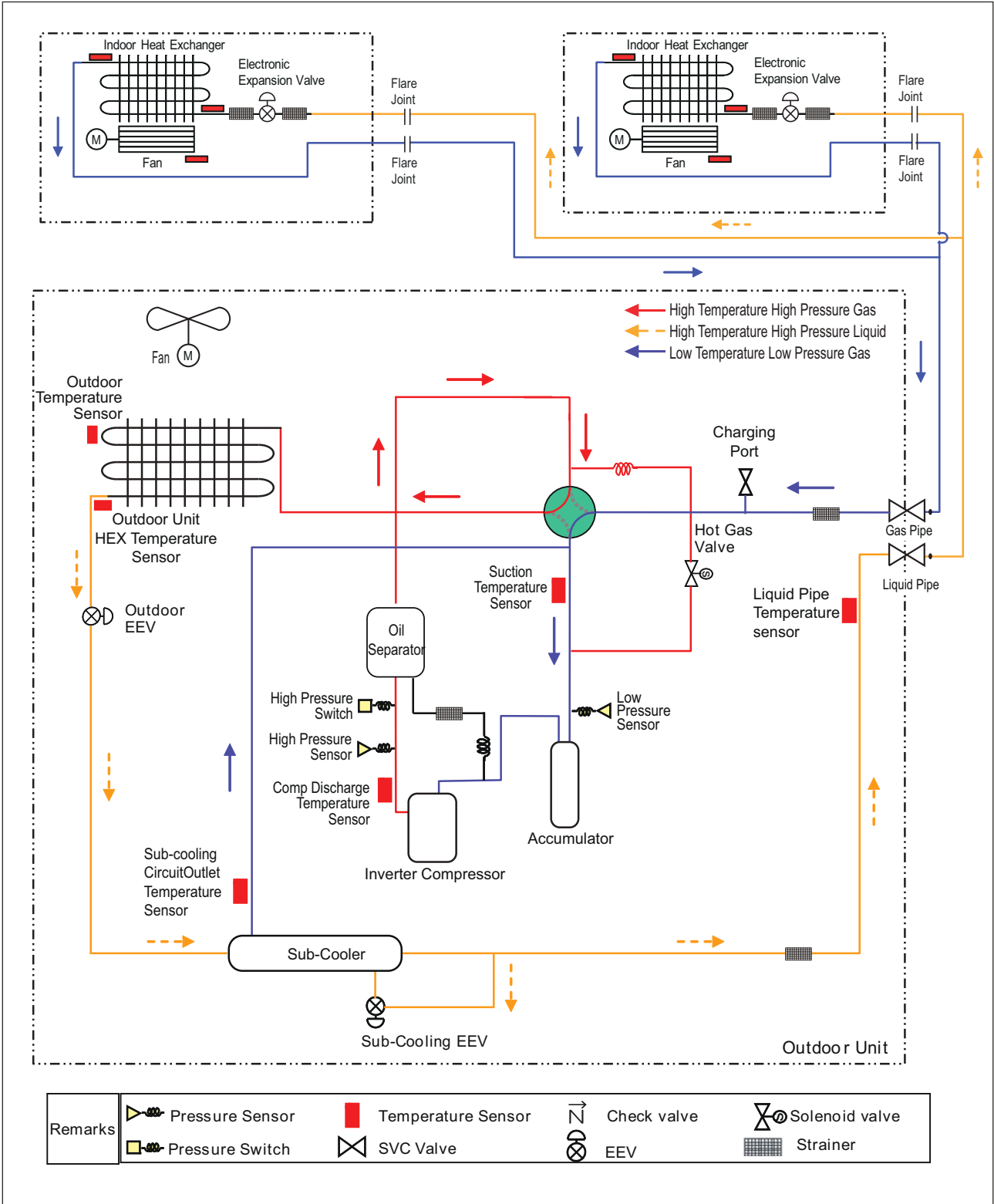

9. Piping Diagrams

9.2 5 HP U4 Chassis (1Ø)

■ Cooling Operation

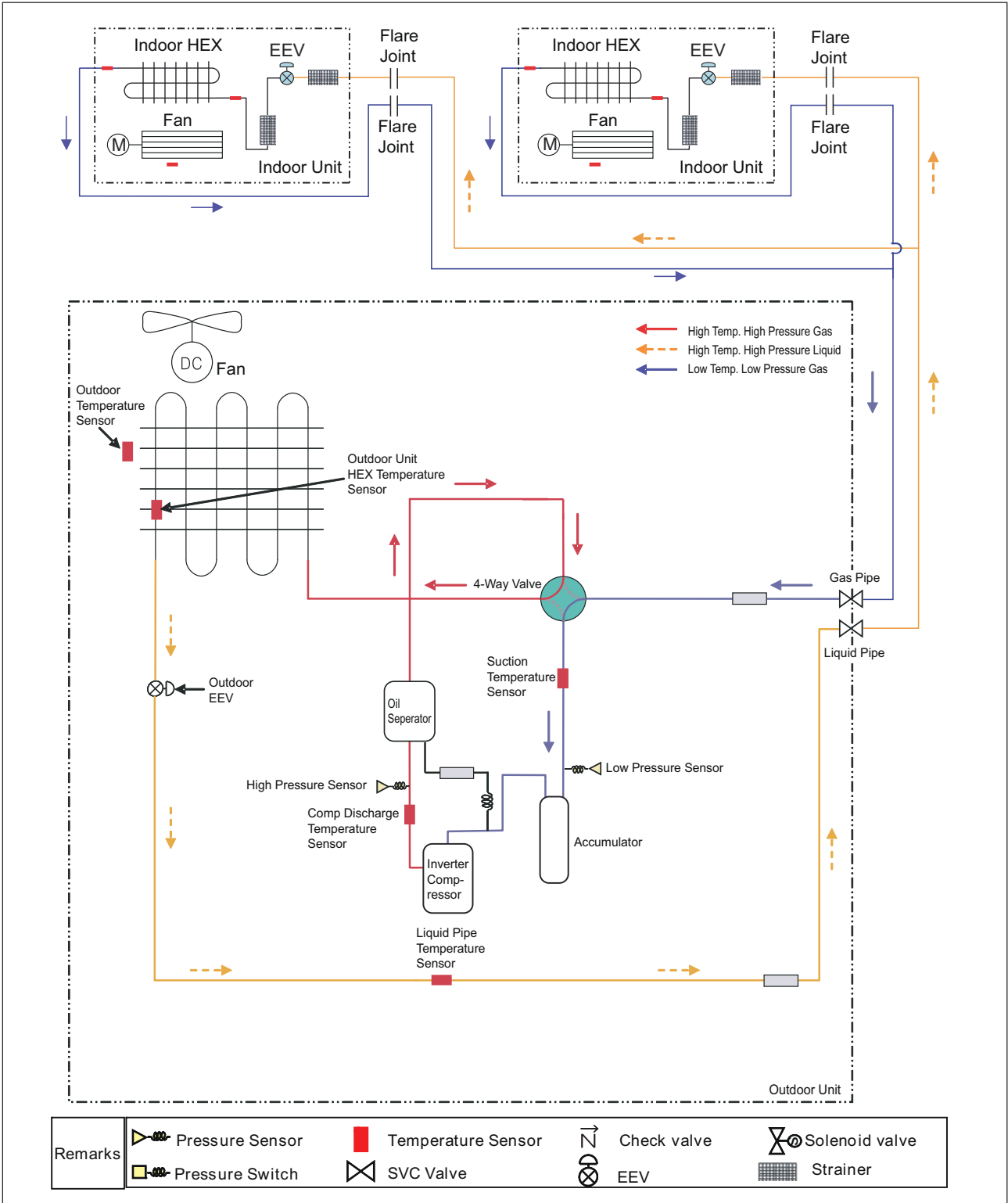

9. Piping Diagrams

■ Heating Operation

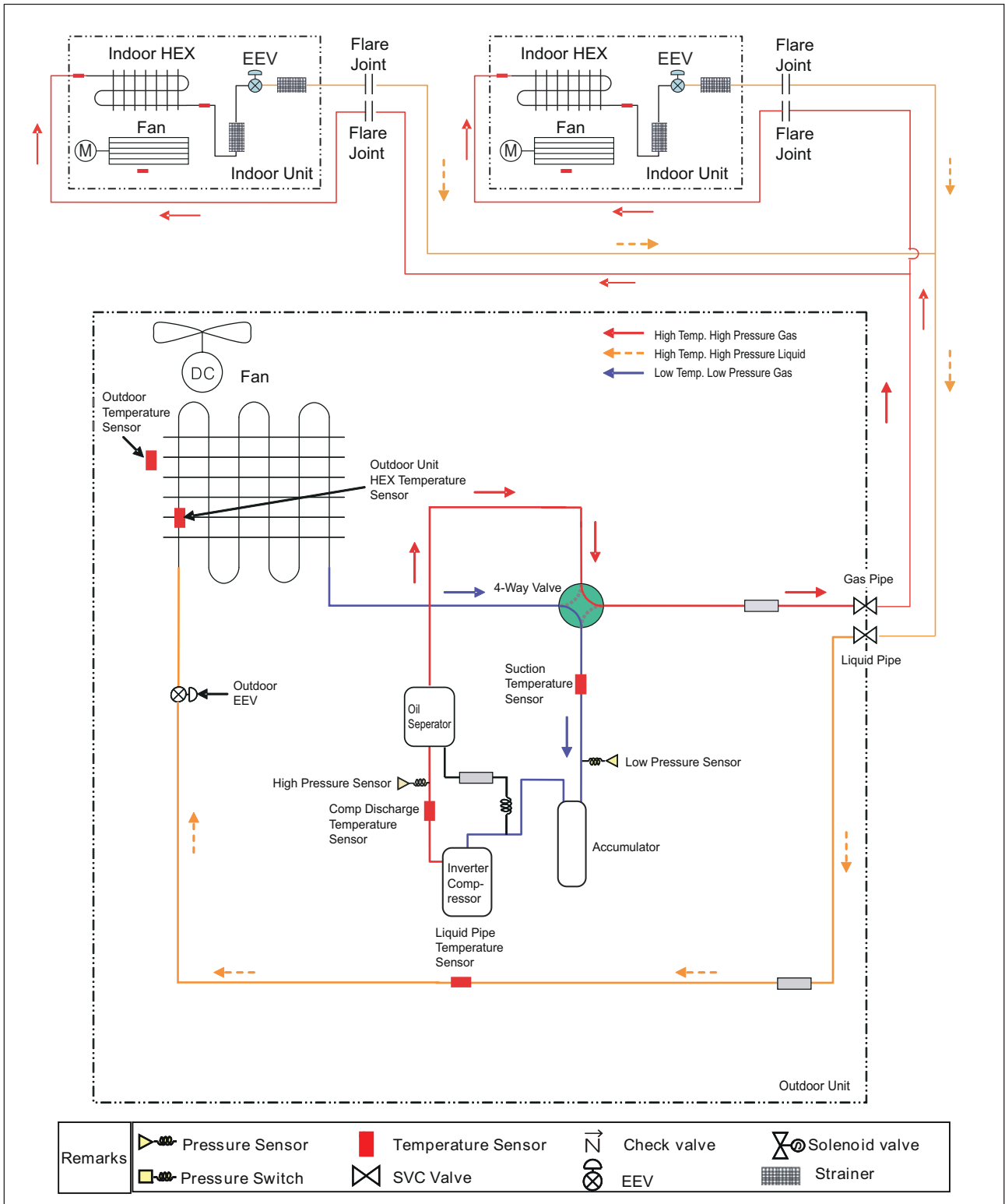

9. Piping Diagrams

Oil Return / Defrost Operation

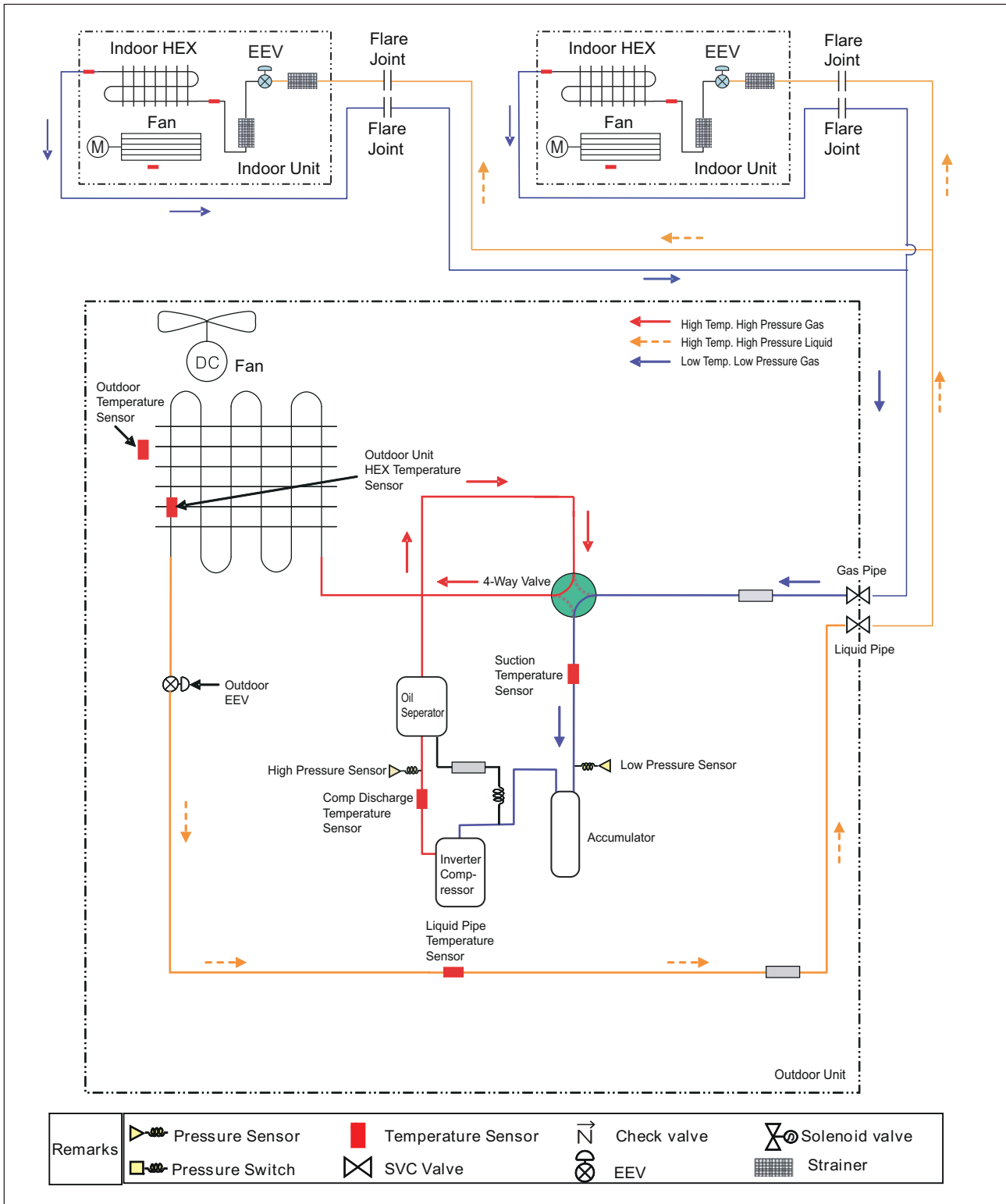

9. Piping Diagrams

9.3 5 / 6 HP U3 Chassis (1Ø), 4 / 5 / 6 / 8 HP U3 Chassis (3Ø)

■ Cooling Operation

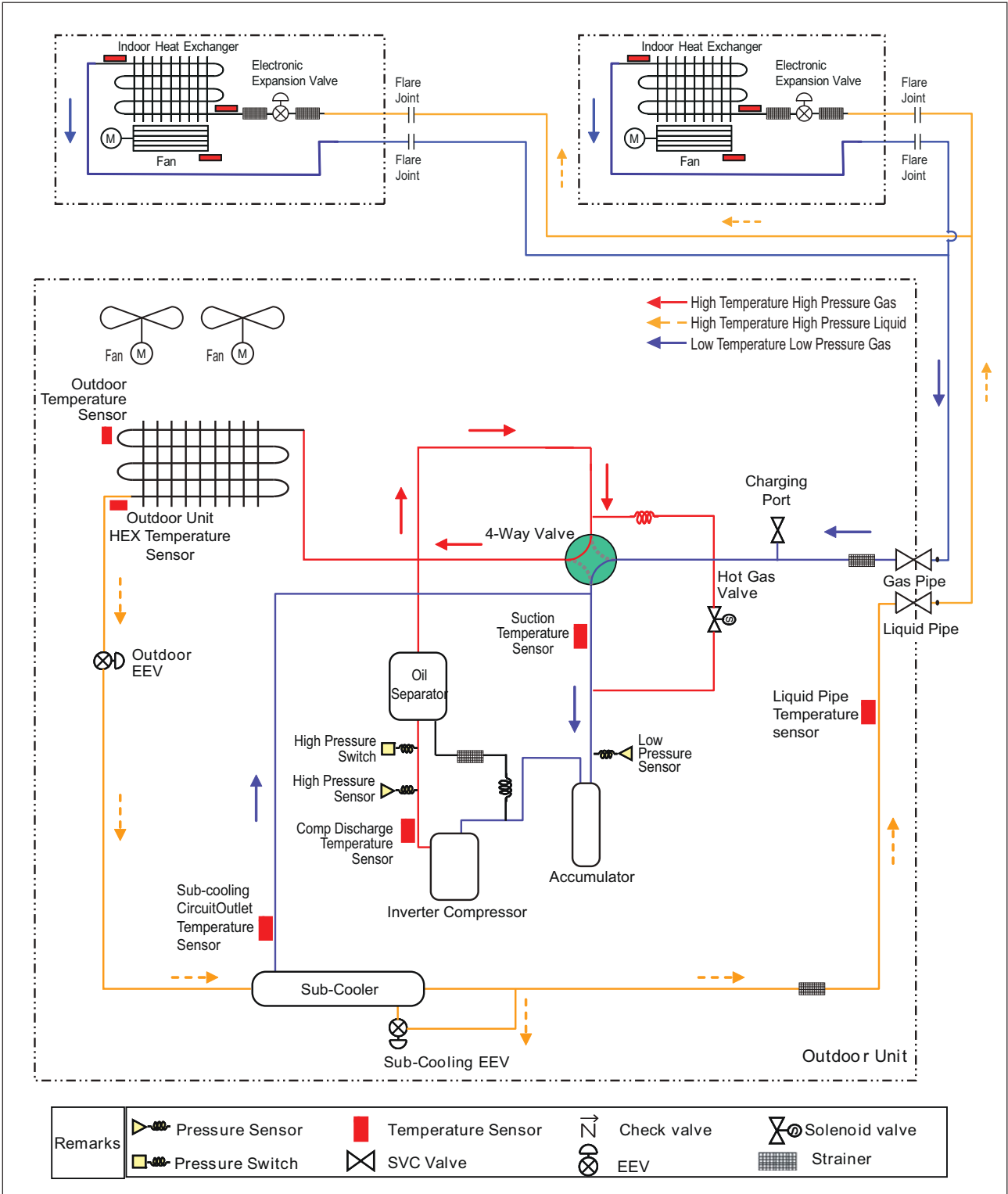

9. Piping Diagrams

■ Heating Operation

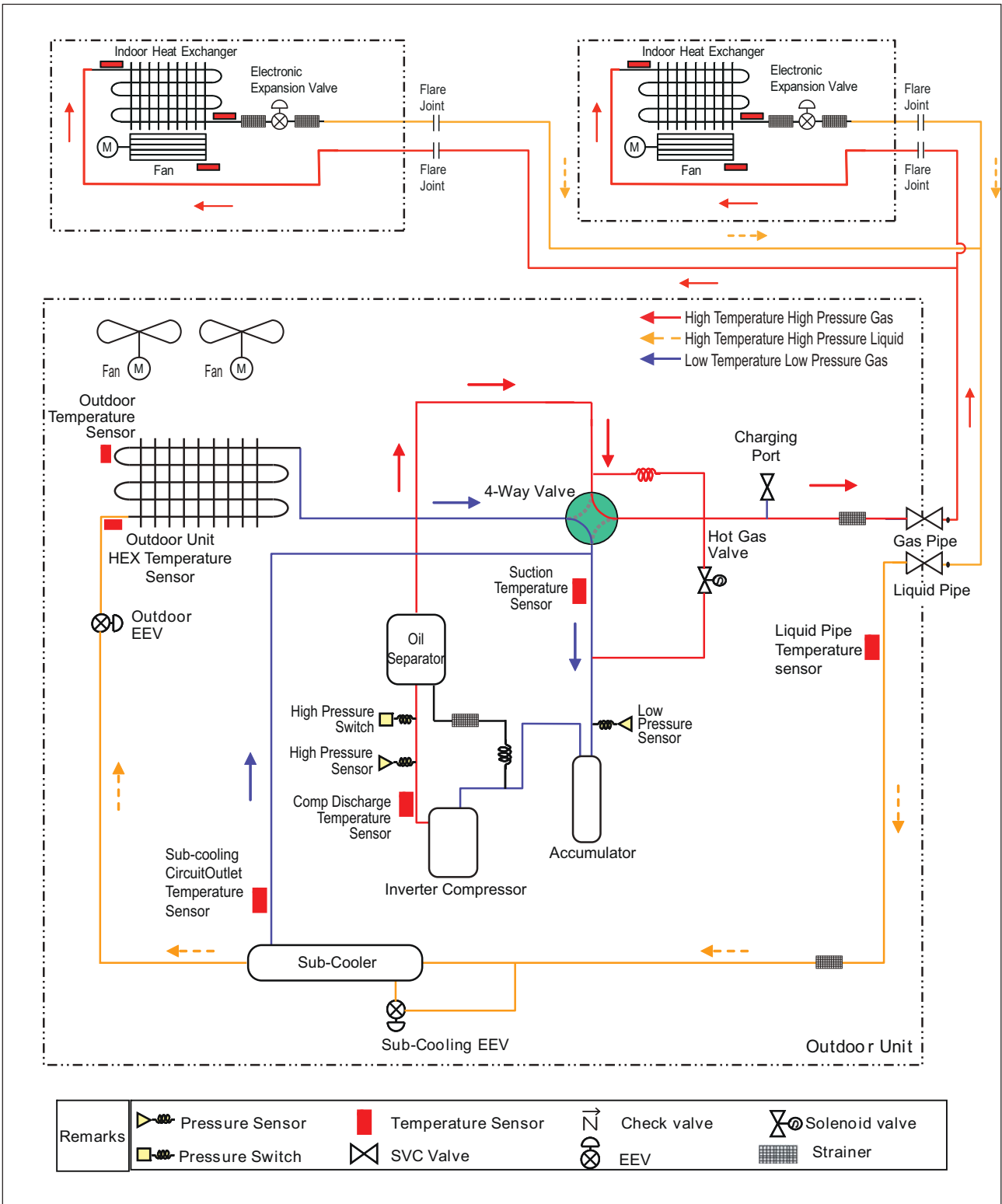

9. Piping Diagrams

Oil Return / Defrost Operation

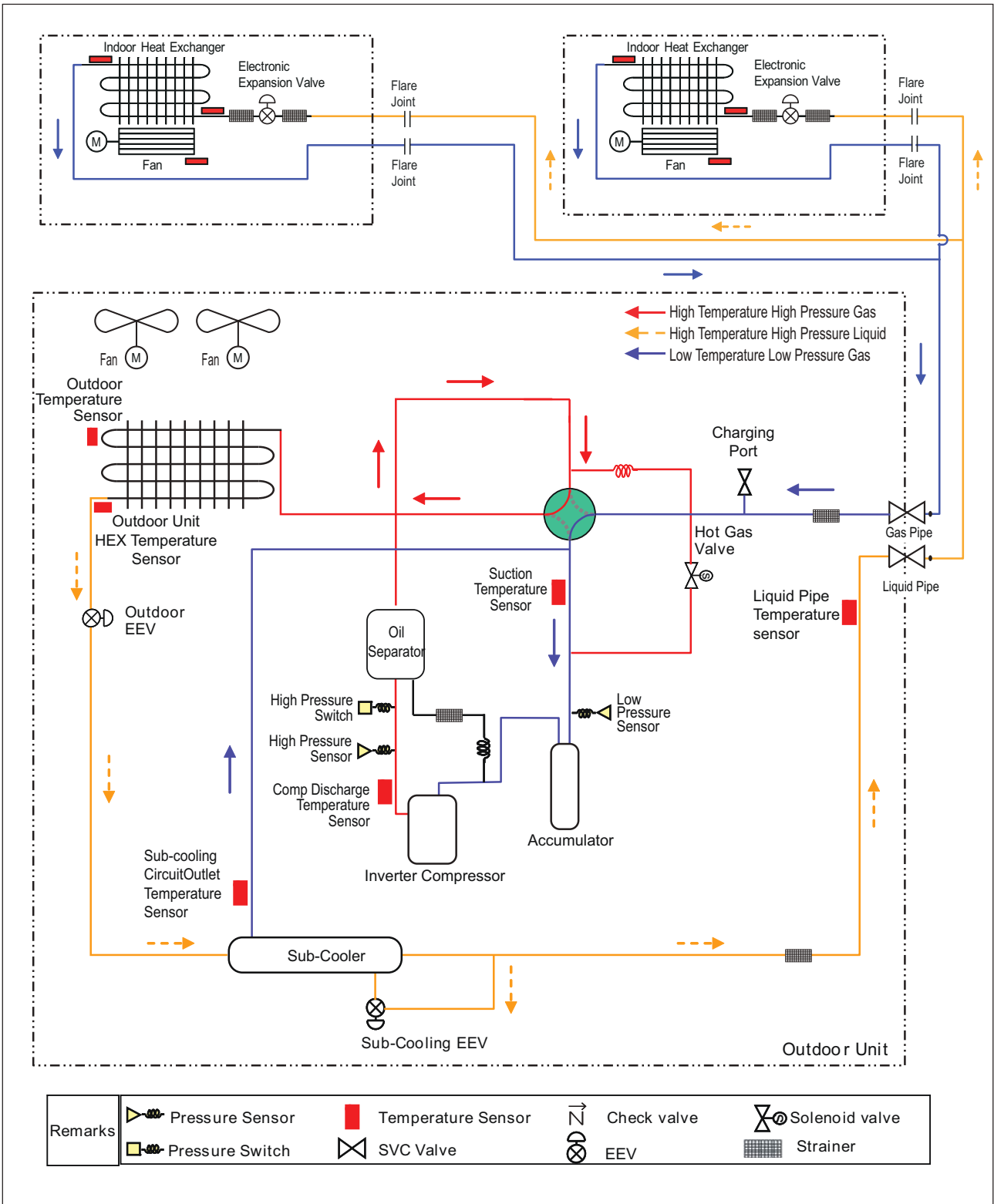

9. Piping Diagrams

9.4 10 / 12 HP U7 Chassis (3Ø)

■ Cooling Operation

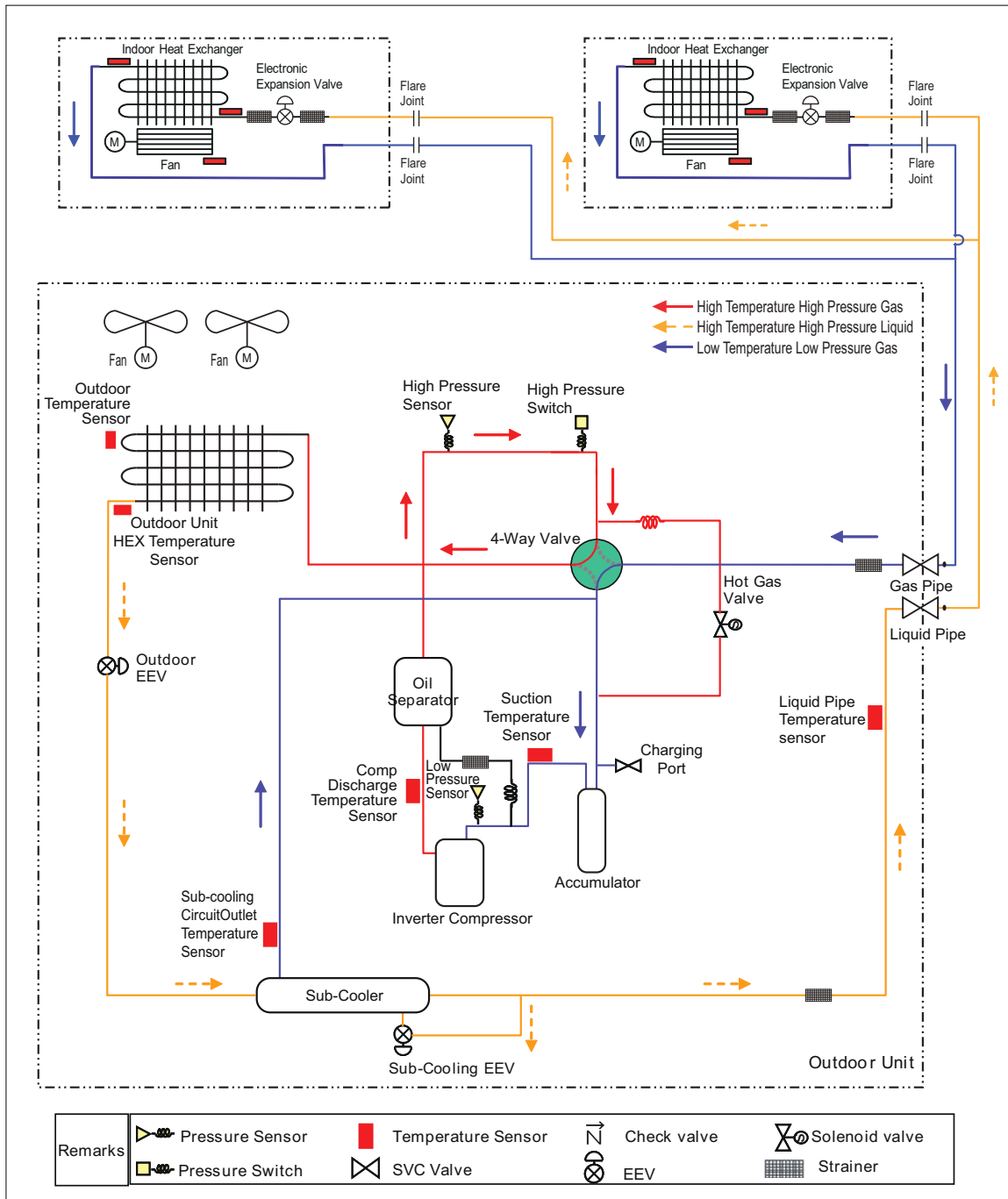

9. Piping Diagrams

■ Heating Operation

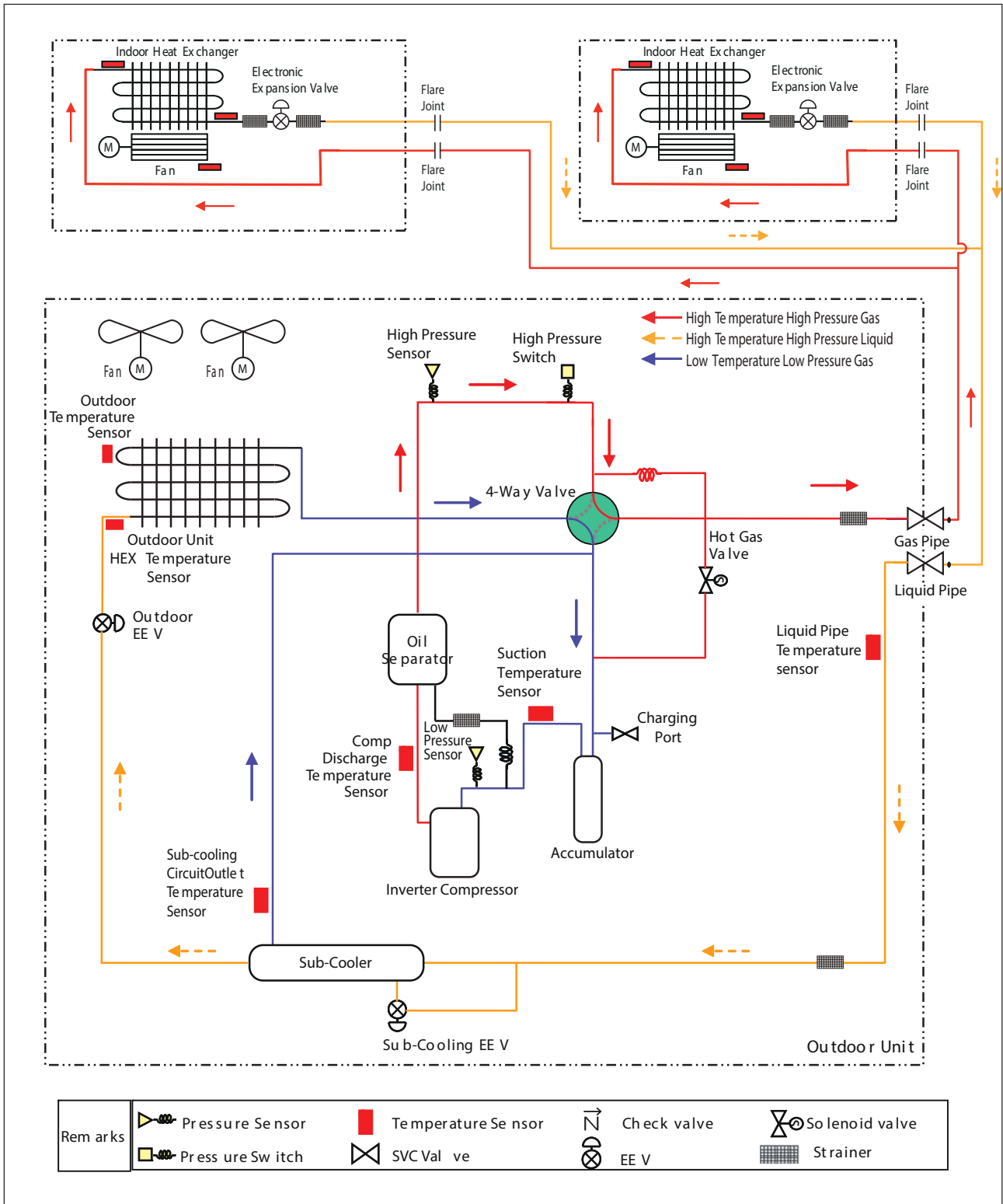

9. Piping Diagrams

Oil Return / Defrost Operation

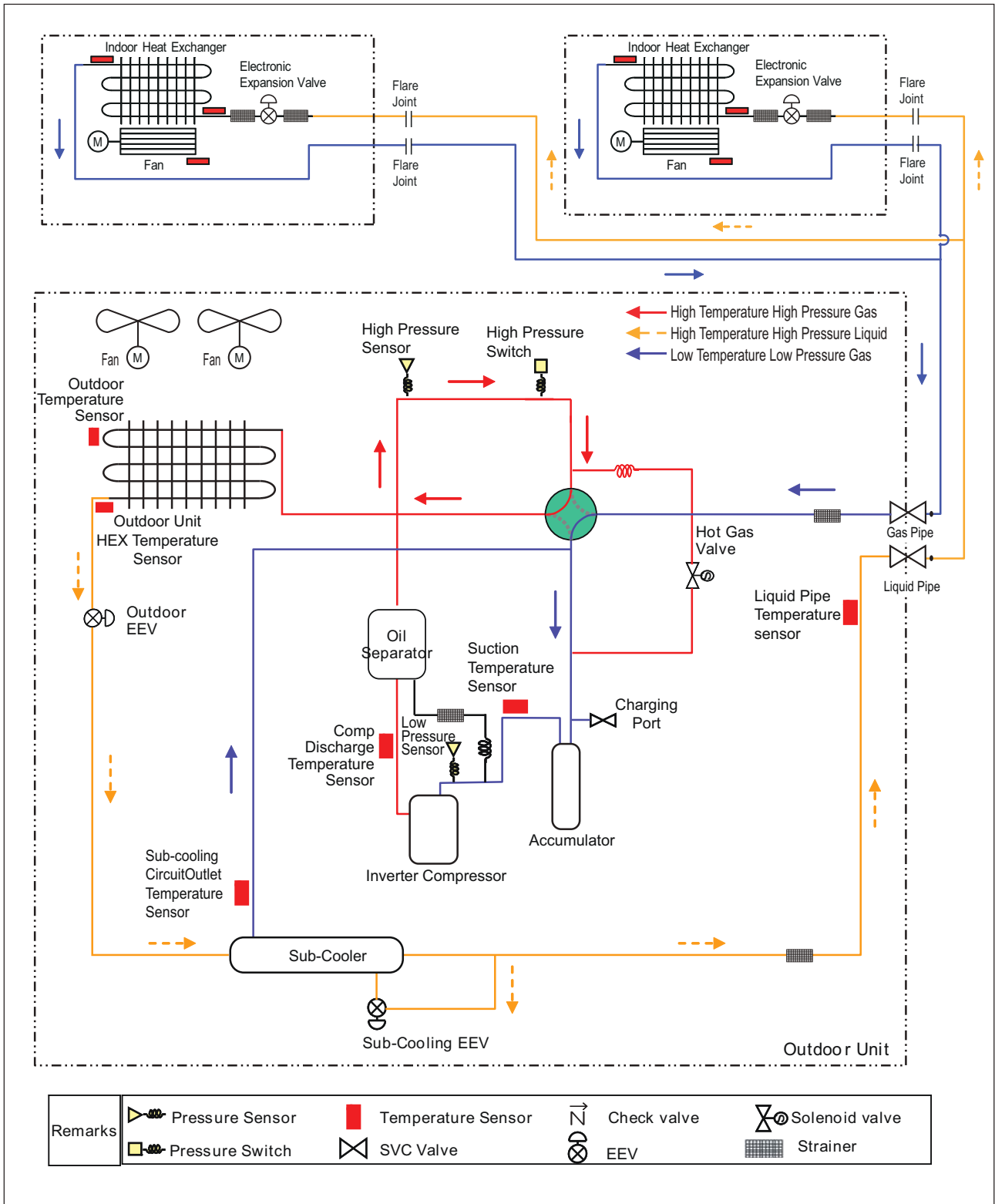

10. Wiring Diagrams

10.1 4 HP U4 Chassis (1Ø)

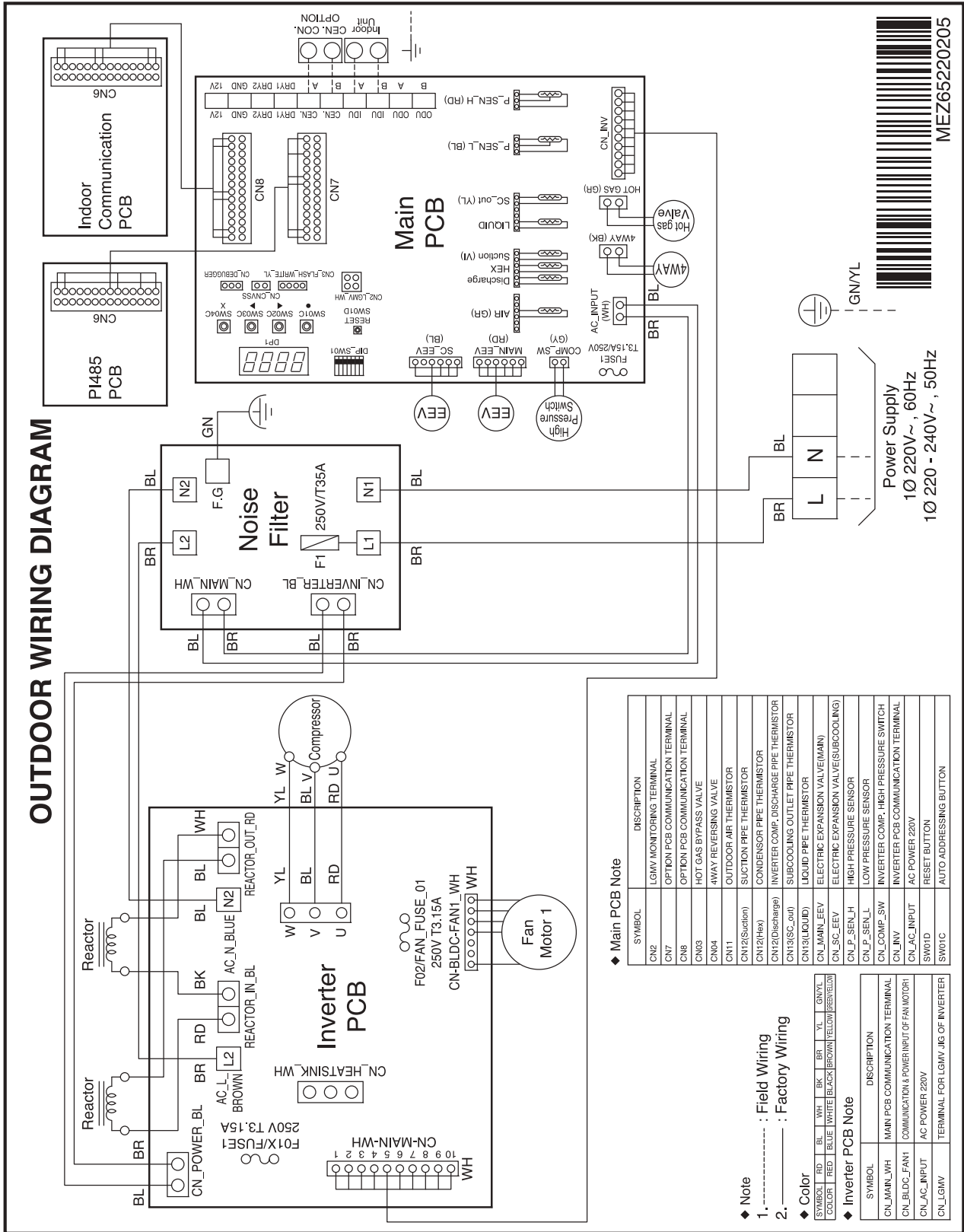

10. Wiring Diagrams

10.2 5 HP U4 Chassis (1Ø)

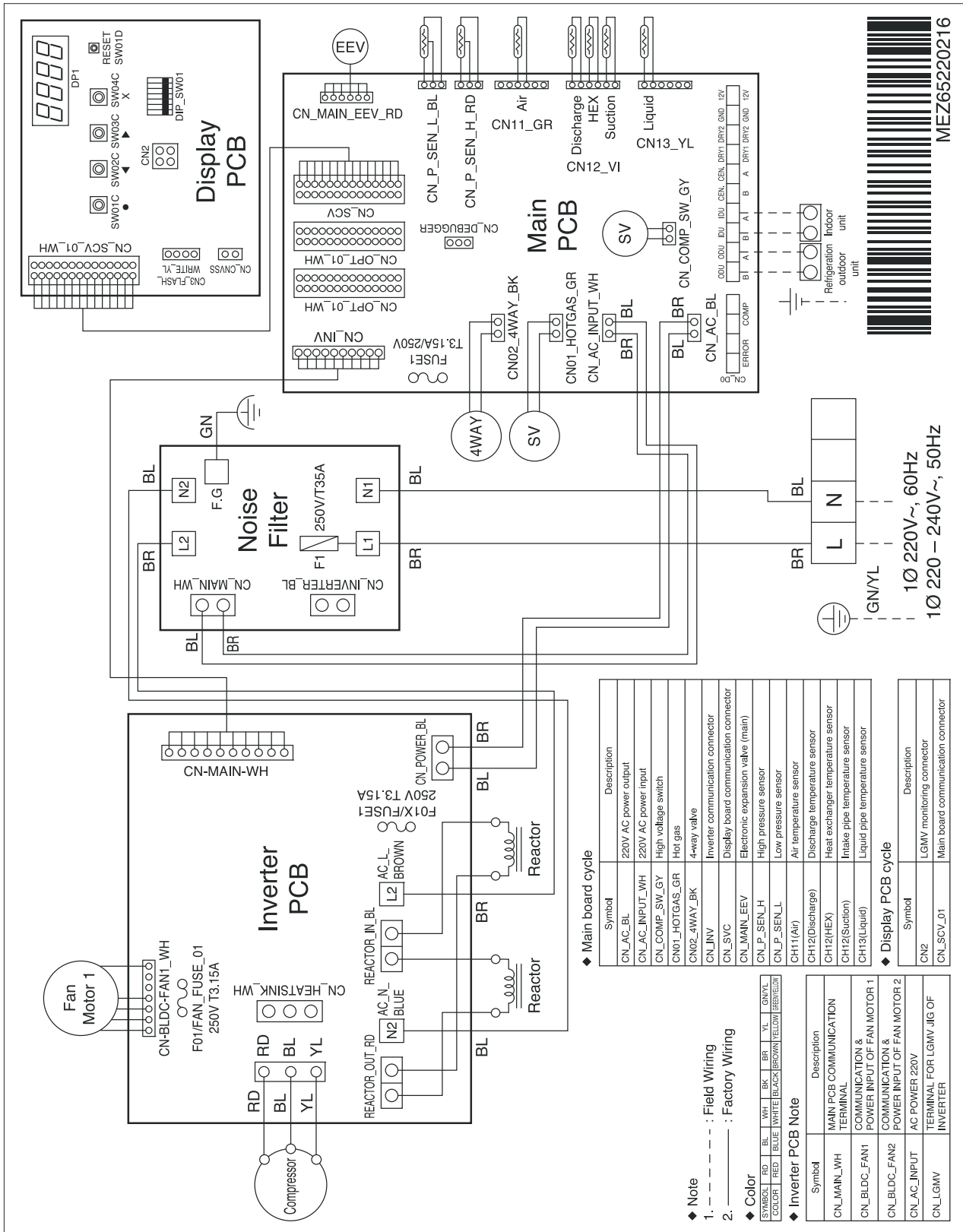

◆ Main board cycle

Symbol	Description
CN_LAC_BL	220V AC power output
CN_LAC_INPUT_WH	220V AC power input
CN_LCOMP_SW_GY	High voltage switch
CN01_HOTGAS_GR	Hot gas
CN02_4WAY_BK	4-way valve
CN_INV	Inverter communication connector
CN_SVC	Display board communication connector
CN_MAIN_EEV	Electronic expansion valve (main)
CN_P_SEN_H	High pressure sensor
CN_P_SEN_L	Low pressure sensor
CH11(Air)	Air temperature sensor
CH12(Discharge)	Discharge temperature sensor
CH12(HEX)	Heat exchanger temperature sensor
CH12(Suction)	Intake pipe temperature sensor
CH13(Liquid)	Liquid pipe temperature sensor

◆ Display PCB cycle

Symbol	Description
CN2	LGWV monitoring connector
CN_SCV_01	Main board communication connector

◆ Note

1. - - - - - : Field Wiring
2. ———— : Factory Wiring

◆ Color

SYMBOL	RD	BL	WH	BK	BR	YL	GN/YL
COLOR	RED	BLUE	WHITE	BLACK	BROWN	YELLOW	GREEN/YELLOW

◆ Inverter PCB Note

Symbol	Description
CN_MAIN_WH	MAIN PCB COMMUNICATION TERMINAL
CN_BLDC_FAN1	COMMUNICATION & POWER INPUT OF FAN MOTOR 1
CN_BLDC_FAN2	COMMUNICATION & POWER INPUT OF FAN MOTOR 2
CN_LAC_INPUT	AC POWER 220V
CN_LGMV	TERMINAL FOR LGWV JIG OF INVERTER

10. Wiring Diagrams

10.3 5 / 6 HP U3 Chassis (1Ø)

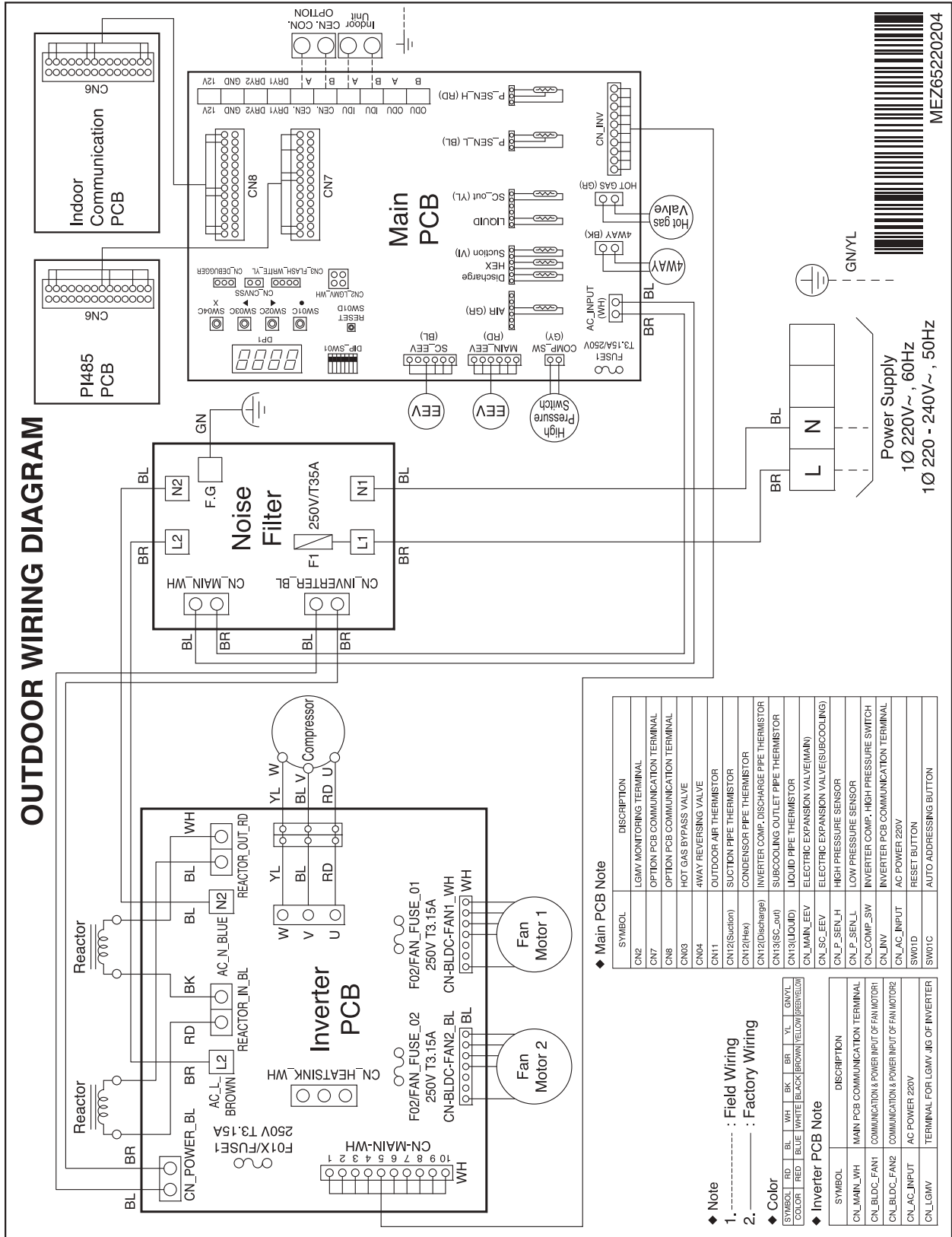

MEZ65220204

Power Supply
1Ø 220V~ , 60Hz
1Ø 220 - 240V~ , 50Hz

10. Wiring Diagrams

10.4 4 / 5 / 6 HP(3Ø)

OUTDOOR WIRING DIAGRAM

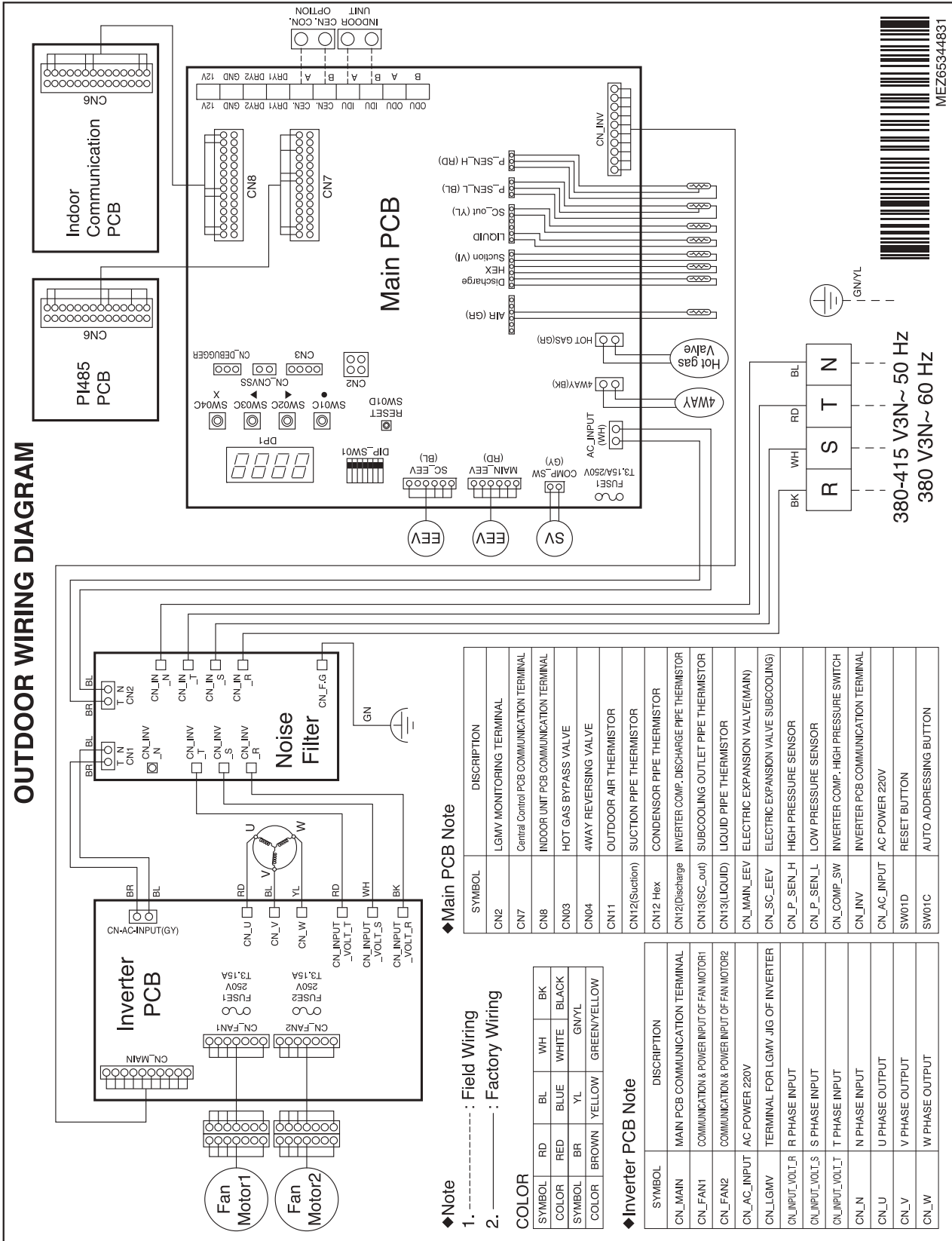

◆ Note

1. - - - - - : Field Wiring
2. ———— : Factory Wiring

COLOR

SYMBOL	RD	BL	WH	BK
COLOR	RED	BLUE	WHITE	BLACK
SYMBOL	BR	YL	GN/YL	
COLOR	BROWN	YELLOW	GREEN/YELLOW	

◆ Main PCB Note

SYMBOL	DESCRIPTION
CN2	LGMV MONITORING TERMINAL
CN7	Central Control PCB COMMUNICATION TERMINAL
CN8	INDOOR UNIT PCB COMMUNICATION TERMINAL
CN03	HOT GAS BYPASS VALVE
CN04	4WAY REVERSING VALVE
CN11	OUTDOOR AIR THERMISTOR
CN12(Suction)	SUCTION PIPE THERMISTOR
CN12 Hex	CONDENSOR PIPE THERMISTOR
CN12(Discharge)	INVERTER COMP. DISCHARGE PIPE THERMISTOR
CN13(SC_out)	SUBCOOLING OUTLET PIPE THERMISTOR
CN13(LIQUID)	LIQUID PIPE THERMISTOR
CN_MAIN_EEV	ELECTRIC EXPANSION VALVE(MAIN)
CN_SC_EEV	ELECTRIC EXPANSION VALVE(SUBCOOLING)
CN_LP_SEN_H	HIGH PRESSURE SENSOR
CN_LP_SEN_L	LOW PRESSURE SENSOR
CN_COMP_SW	INVERTER COMP. HIGH PRESSURE SWITCH
CN_INV	INVERTER PCB COMMUNICATION TERMINAL
CN_AC_INPUT	AC POWER 220V
SW01D	RESET BUTTON
SW01C	AUTO ADDRESSING BUTTON

◆ Inverter PCB Note

SYMBOL	DESCRIPTION
CN_MAIN	MAIN PCB COMMUNICATION TERMINAL
CN_FAN1	COMMUNICATION & POWER INPUT OF FAN MOTOR1
CN_FAN2	COMMUNICATION & POWER INPUT OF FAN MOTOR2
CN_AC_INPUT	AC POWER 220V
CN_LGMV	TERMINAL FOR LGMV JIG OF INVERTER
CN_INPUT_VOLT_R	R PHASE INPUT
CN_INPUT_VOLT_S	S PHASE INPUT
CN_INPUT_VOLT_T	T PHASE INPUT
CN_N	N PHASE INPUT
CN_U	U PHASE OUTPUT
CN_V	V PHASE OUTPUT
CN_W	W PHASE OUTPUT



380-415 V3N~50 Hz
380 V3N~60 Hz

10. Wiring Diagrams

10.5 8 HP(3Ø)

OUTDOOR WIRING DIAGRAM

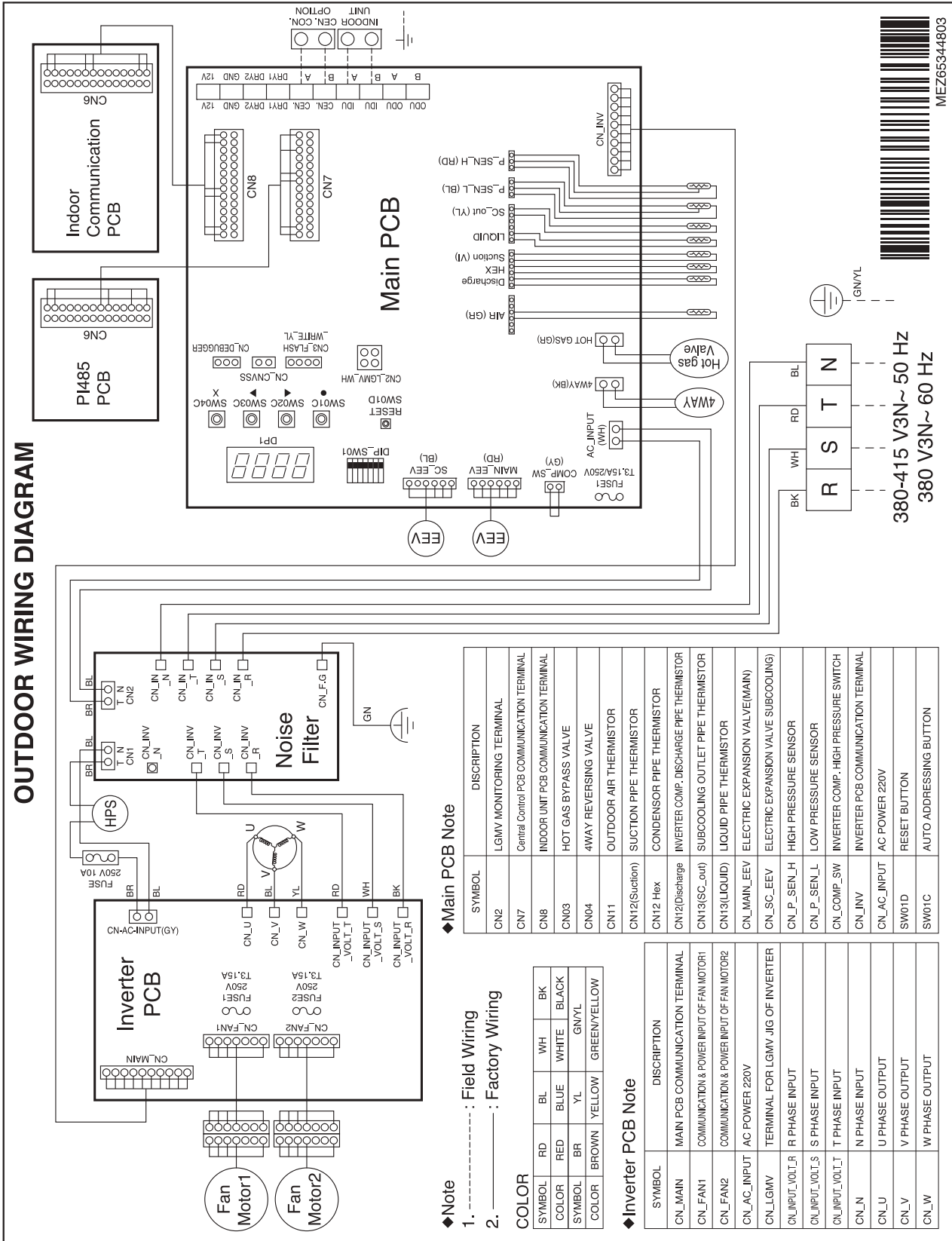

380-415 V3N~50 Hz
380 V3N~60 Hz

◆Note
1. - - - - - : Field Wiring
2. ———— : Factory Wiring

◆Main PCB Note

SYMBOL	DESCRIPTION
CN2	LGMV MONITORING TERMINAL
CN7	Central Control PCB COMMUNICATION TERMINAL
CN8	INDOOR UNIT PCB COMMUNICATION TERMINAL
CN03	HOT GAS BYPASS VALVE
CN04	4WAY REVERSING VALVE
CN11	OUTDOOR AIR THERMISTOR
CN12(Suction)	SUCTION PIPE THERMISTOR
CN12 Hex	CONDENSOR PIPE THERMISTOR
CN12/Discharge	INVERTER COMP. DISCHARGE PIPE THERMISTOR
CN13(SC_out)	SUBCOOLING OUTLET PIPE THERMISTOR
CN13(LIQUID)	LIQUID PIPE THERMISTOR
CN_MAIN_EEV	ELECTRIC EXPANSION VALVE(MAIN)
CN_SC_EEV	ELECTRIC EXPANSION VALVE(SUBCOOLING)
CN_LP_SEN_H	HIGH PRESSURE SENSOR
CN_LP_SEN_L	LOW PRESSURE SENSOR
CN_COMP_SW	INVERTER COMP. HIGH PRESSURE SWITCH
CN_INV	INVERTER PCB COMMUNICATION TERMINAL
CN_AC_INPUT	AC POWER 220V
SW01D	RESET BUTTON
SW01C	AUTO ADDRESSING BUTTON

◆Inverter PCB Note

SYMBOL	DESCRIPTION
CN_MAIN	MAIN PCB COMMUNICATION TERMINAL
CN_FAN1	COMMUNICATION & POWER INPUT OF FAN MOTOR1
CN_FAN2	COMMUNICATION & POWER INPUT OF FAN MOTOR2
CN_AC_INPUT	AC POWER 220V
CN_LGMV	TERMINAL FOR LGMV JIG OF INVERTER
CN_INPUT_VOLT_R	R PHASE INPUT
CN_INPUT_VOLT_S	S PHASE INPUT
CN_INPUT_VOLT_T	T PHASE INPUT
CN_N	N PHASE INPUT
CN_U	U PHASE OUTPUT
CN_V	V PHASE OUTPUT
CN_W	W PHASE OUTPUT

COLOR
SYMBOL RD BL WH BK
COLOR RED BLUE WHITE BLACK
SYMBOL BR YL GN/YL
COLOR BROWN YELLOW GREEN/YELLOW

10. Wiring Diagrams

10.6 10 / 12 HP(3Ø)

OUTDOOR WIRING DIAGRAM

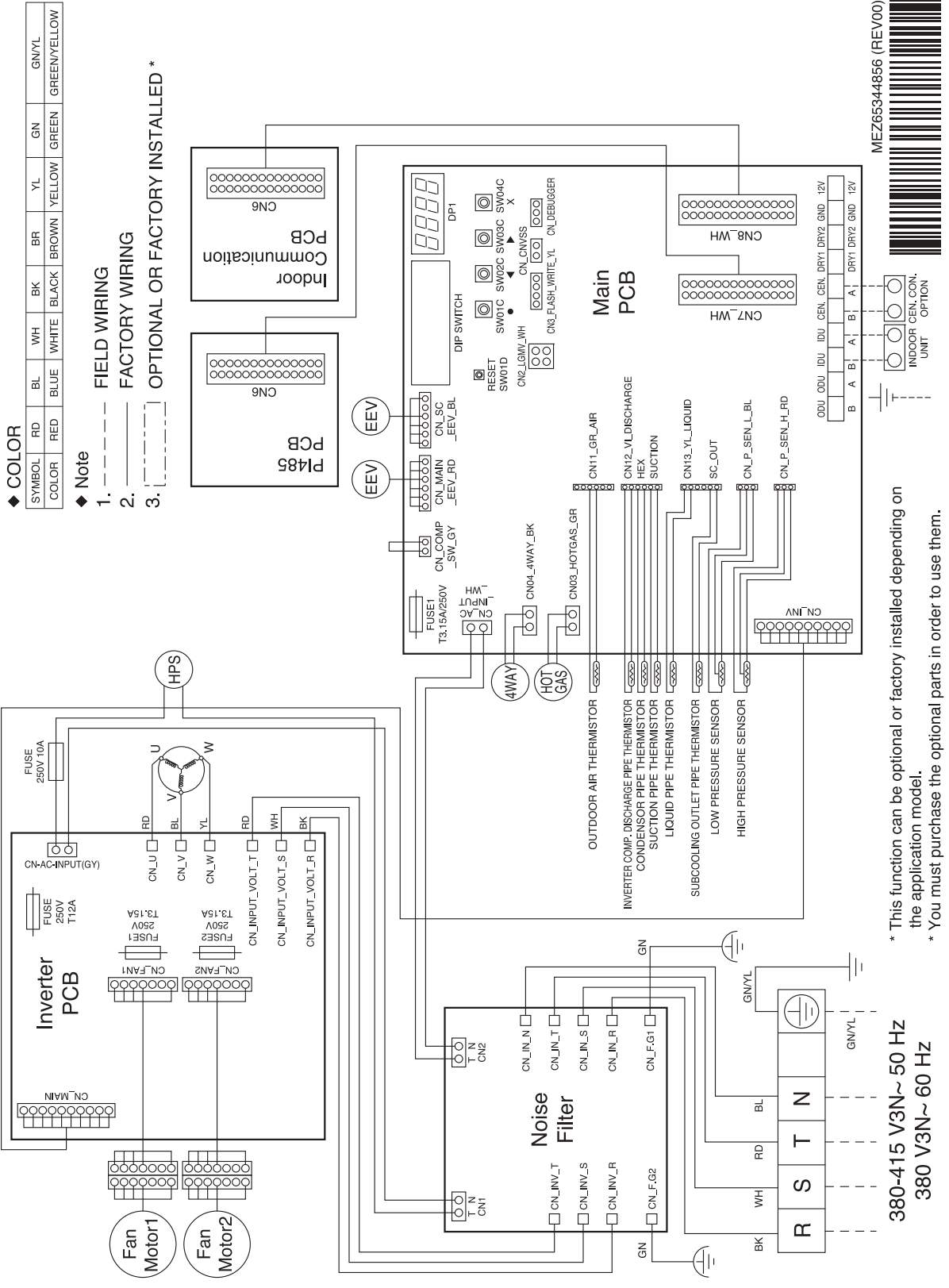

11. Field Wiring

11.1 50Hz/60Hz (1Ø)

■ Example Connection of Communication Cable

◆ Single Outdoor Unit

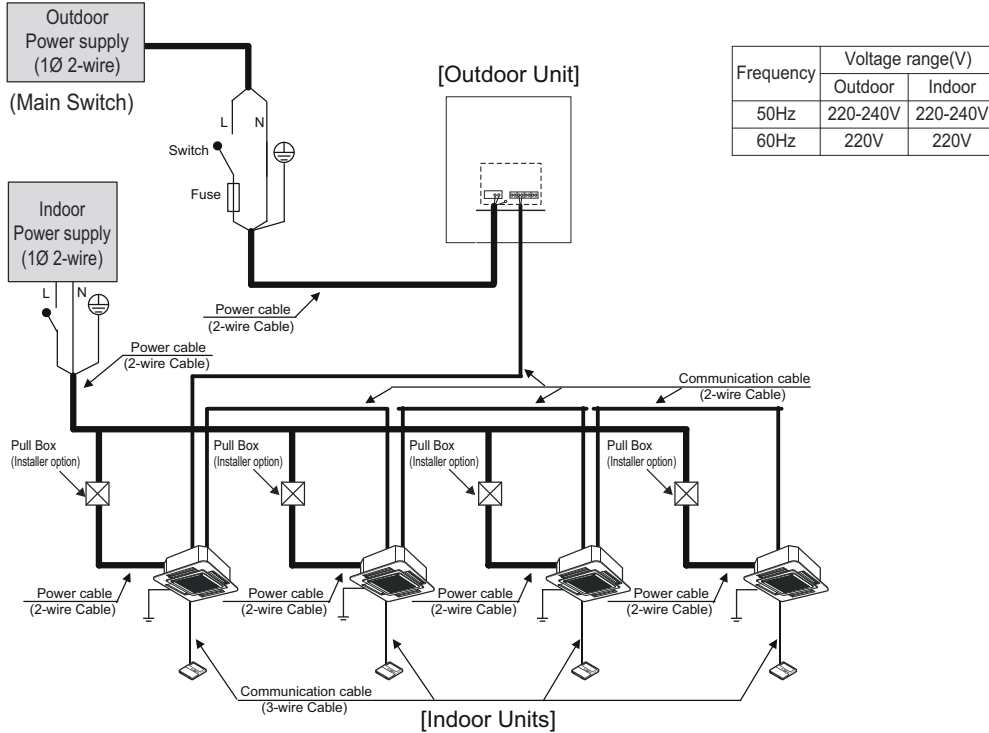

⚠ WARNING

- Indoor Unit ground Lines are required for preventing electrical shock accident during current leakage, Communication disorder by noise effect and motor current leakage (without connection to pipe).
 - Don't install an individual switch or electrical outlet to disconnect each of indoor unit separately from the power supply.
 - Install the main switch that can interrupt all the power sources in an integrated manner because this system consists of the equipment utilizing the multiple power sources.
 - If there exists the possibility of reversed phase, lose phase, momentary blackout or the power goes on and off while the product is operating, attach a reversed phase protection circuit locally.
- Running the product in reversed phase may break the compressor and other parts.

Between Indoor and Outdoor unit

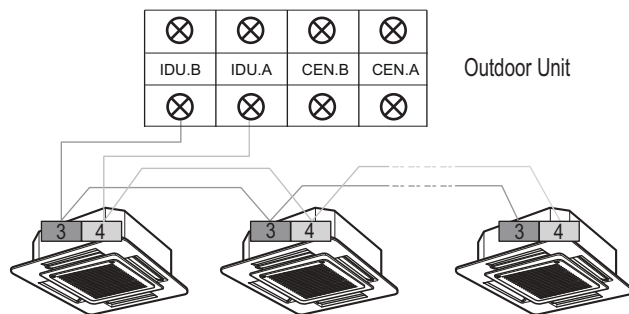

11. Field Wiring

11.2 50Hz/60Hz (3Ø)

■ Example Connection of Communication Cable

◆ Single Outdoor Unit

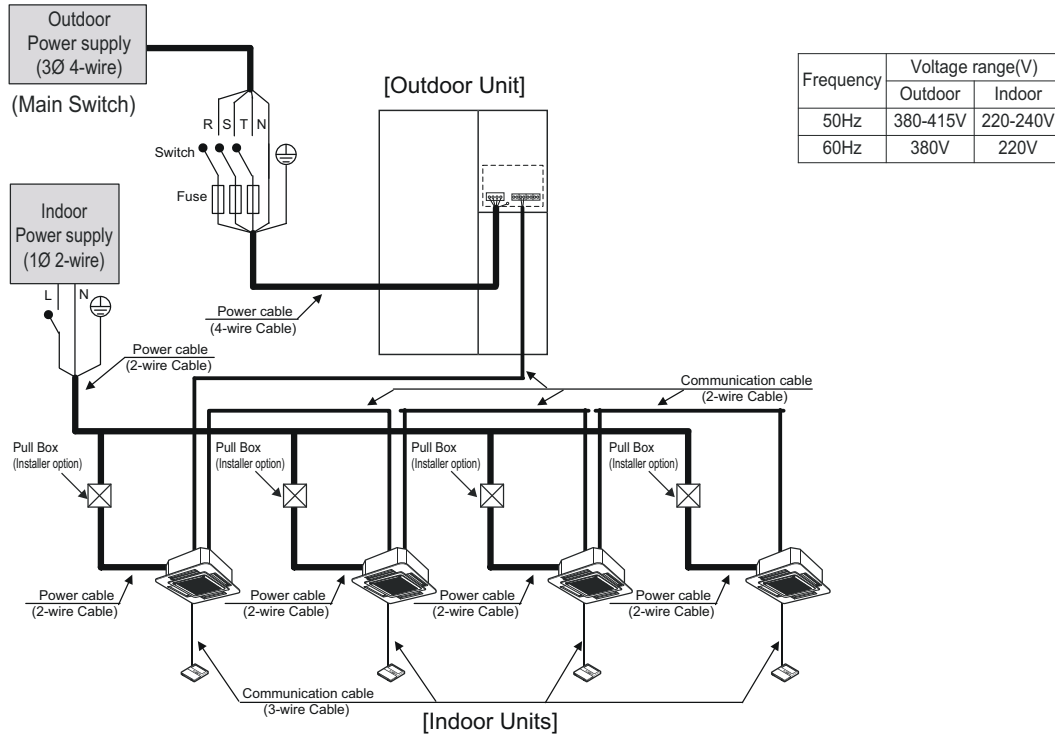

⚠ WARNING

- Indoor Unit ground Lines are required for preventing electrical shock accident during current leakage, Communication disorder by noise effect and motor current leakage (without connection to pipe).
- Don't install an individual switch or electrical outlet to disconnect each of indoor unit separately from the power supply.
- Install the main switch that can interrupt all the power sources in an integrated manner because this system consists of the equipment utilizing the multiple power sources.
- If there exists the possibility of reversed phase, lose phase, momentary blackout or the power goes on and off while the product is operating, attach a reversed phase protection circuit locally.
Running the product in reversed phase may break the compressor and other parts.

Between Indoor and Master Outdoor unit

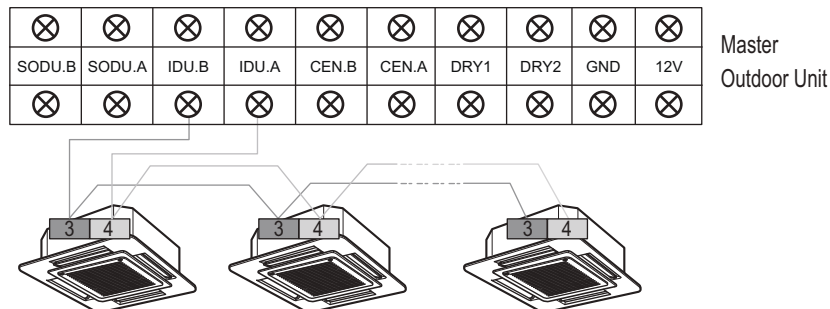

The GND terminal at the main PCB is a '-' terminal for day contact, it is not the point to make ground connection.

11. Field Wiring

■ Example Connection of Communication Cable

[BUS type]

- Connection of communication cable must be installed like below figure between indoor unit to outdoor unit.

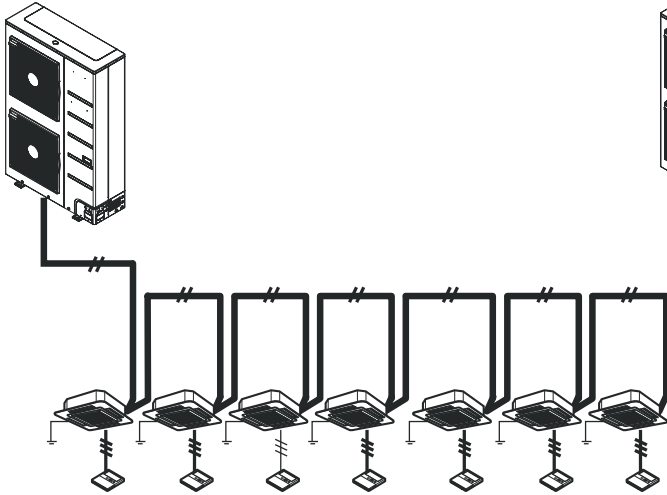

[STAR type]

- Abnormal operation can be caused by communication defect, when connection of communication cable is installed like below figure (STAR type).

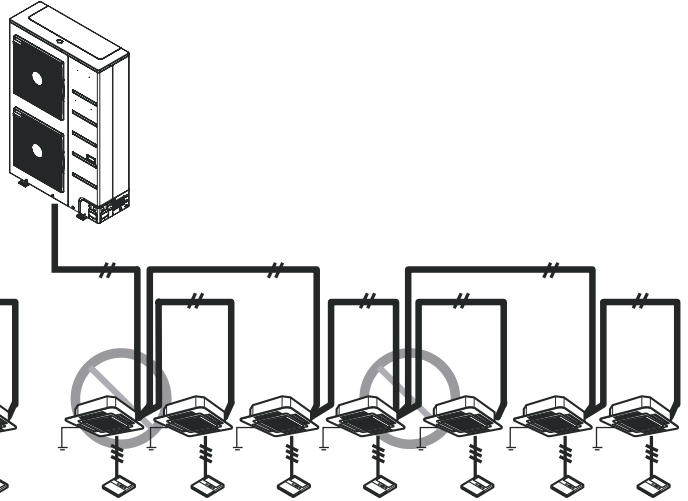

12. Sound Levels

12.1 Sound Pressure Level

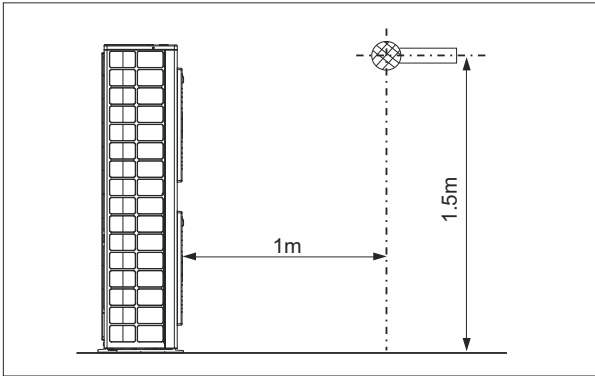

Note

- 1.Data is valid at free field condition.
- 2.Reference accoustic pressure 0dB = 20μPa.
- 3.Data is valid at nominal operation condition.
Refer to the Model Specifications for nominal conditions(Power source and Ambient temperature, etc)
- 4.Sound levels can be increased in accordance with installation and operating conditions. (Operating conditions include some functional condition like Static pressure mode, air guide use, Room target temperature setting, etc and these functions are different in accordance with each model.)
- 5.Sound level will vary depending on a range of factors such as the construction(acoustic absorption coefficient) of particular room in which the equipment in installed.
- 6.Sound pressure level is measured on the rated condition in the anechoic rooms by ISO 3745 standard.
Therefore, these values can be increased owing to ambient conditions during operation.

Model	Sound Pressure Levels [dB(A)]	
	Cooling	Heating
ARUN040GSS0	50	52
ARUN050GSL0	52	58
ARUN050GSS0	51	53
ARUN060GSS0	52	54
ARUN040LSS0	50	52
ARUN050LSS0	51	53
ARUN060LSS0	52	54
ARUN080LSS0	57	57
ARUN100LSS0	58	58
ARUN120LSS0	60	60

◆ **Cooling**

ARUN040GSS0

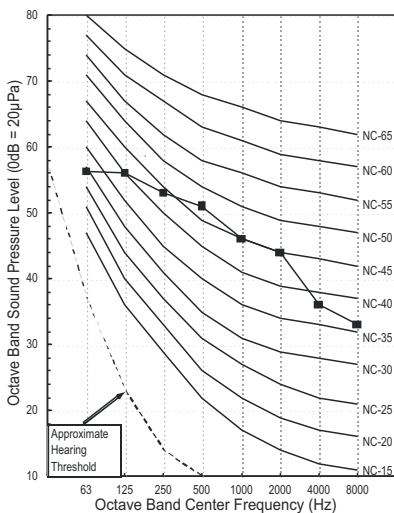

ARUN050GSL0

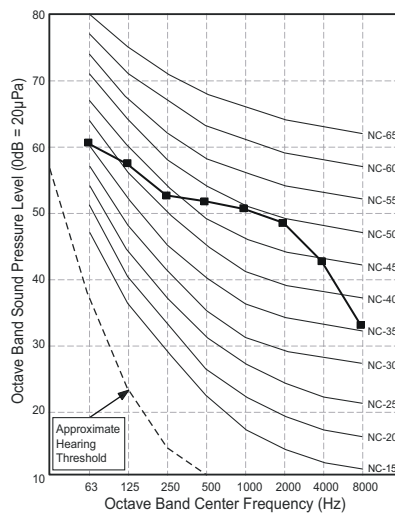

ARUN050GSS0

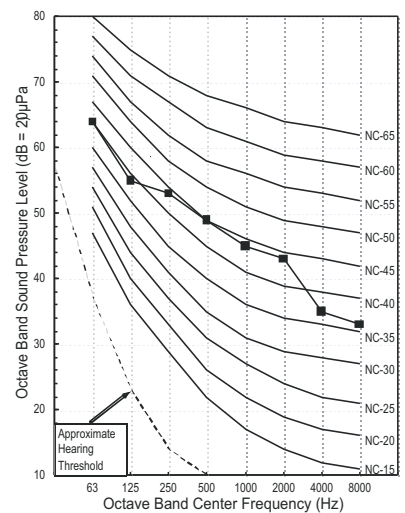

12. Sound Levels

ARUN060GSS0

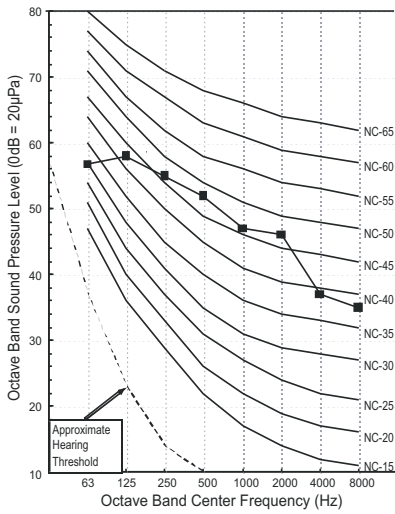

ARUN040LSS0

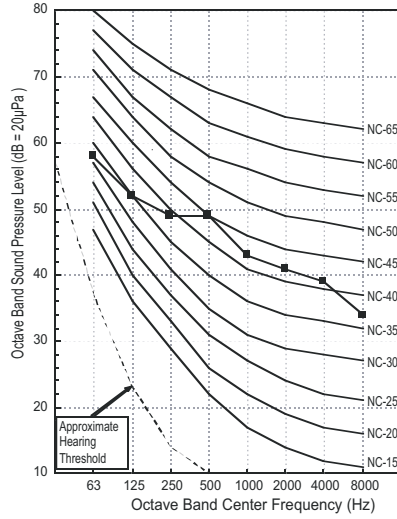

ARUN050LSS0

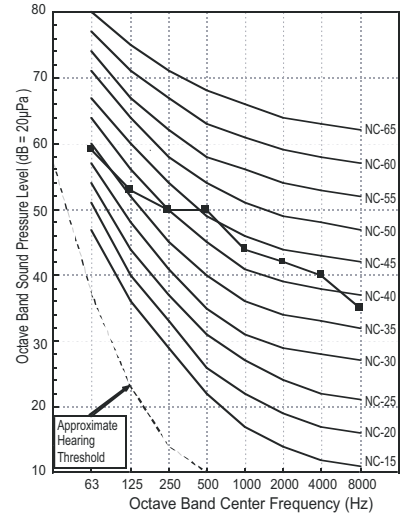

ARUN060LSS0

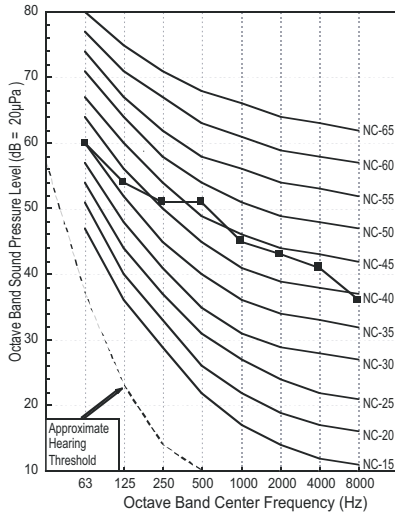

ARUN080LSS0

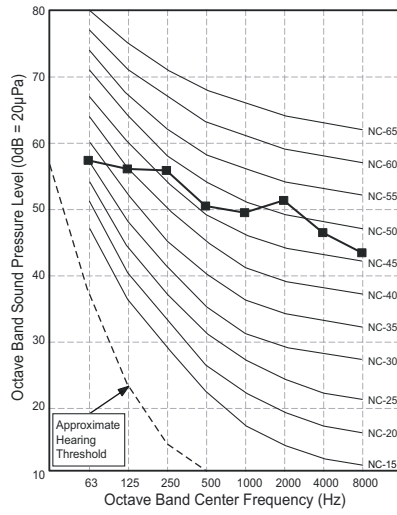

ARUN100LSS0

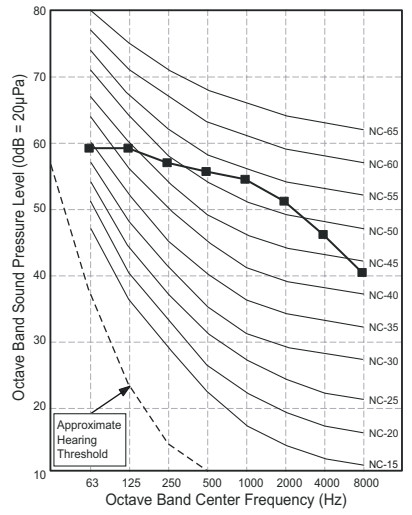

ARUN120LSS0

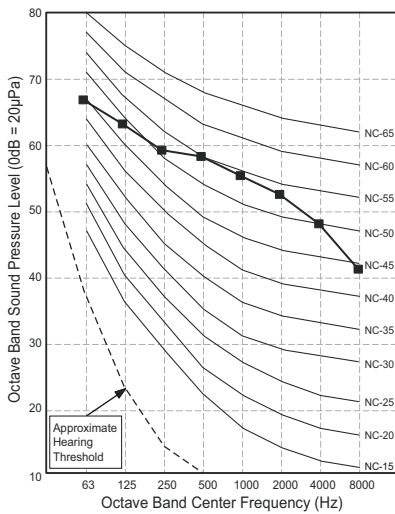

12. Sound Levels

◆ Heating

ARUN040GSS0

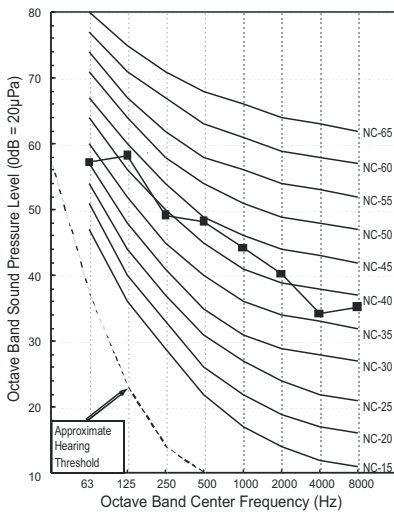

ARUN050GSL0

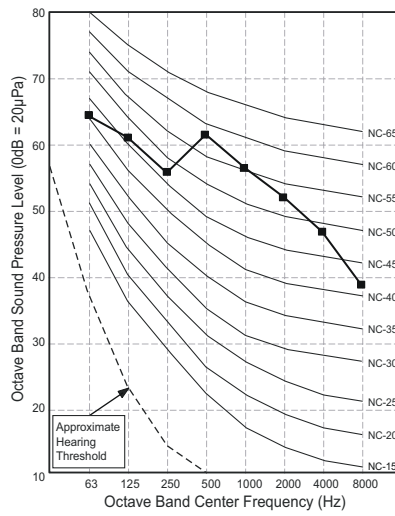

ARUN050GSS0

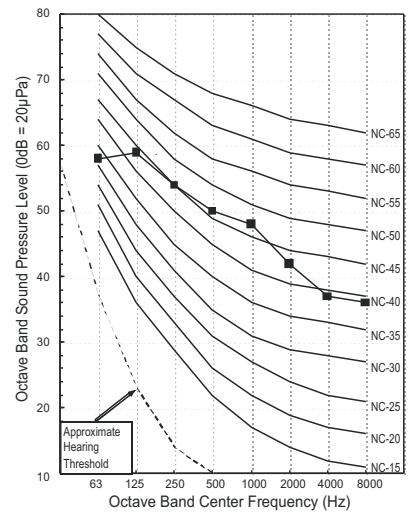

ARUN060GSS0

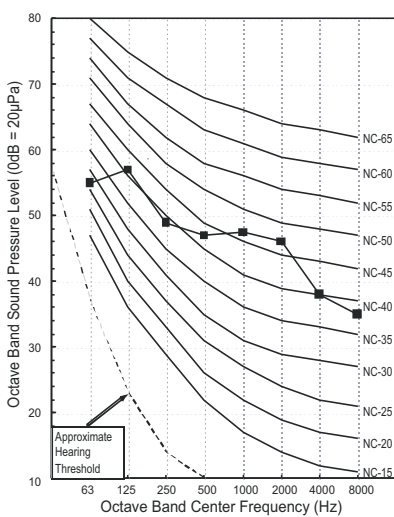

ARUN040LSS0

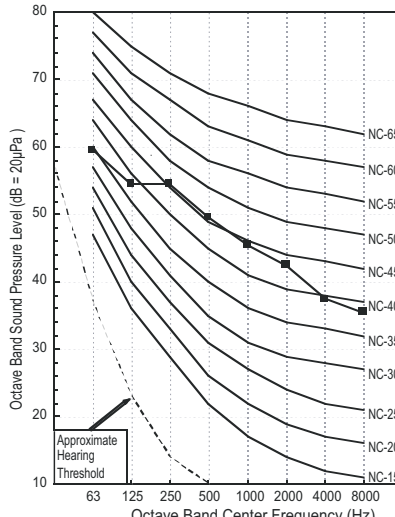

ARUN050LSS0

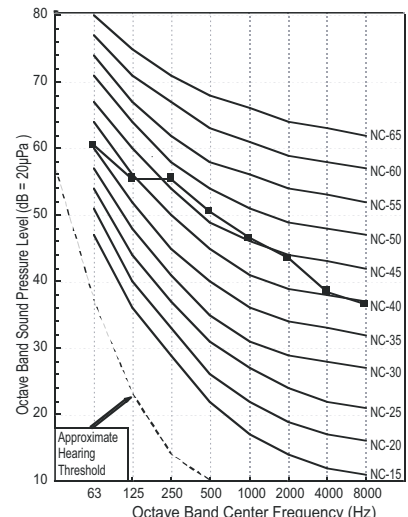

ARUN060LSS0

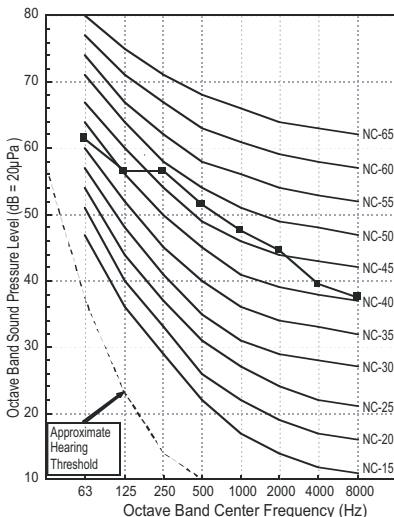

ARUN080LSS0

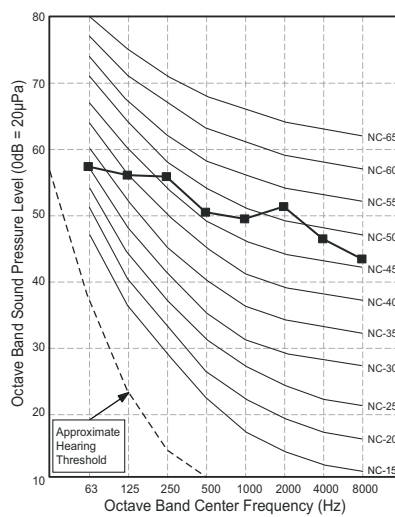

ARUN100LSS0

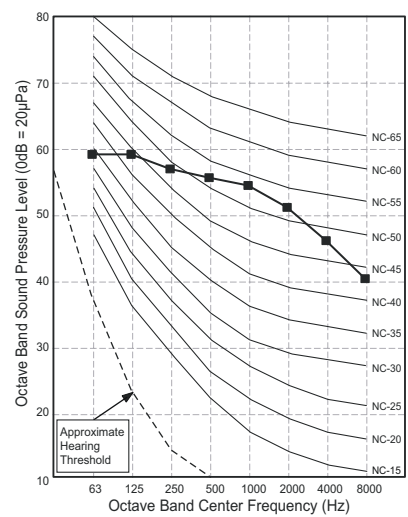

12. Sound Levels

ARUN120LSS0

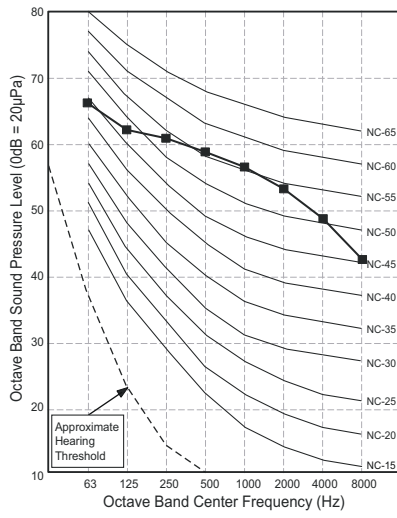

12. Sound Levels

12.2 Sound Power Levels

Note

1. Data is valid at diffuse field condition.
2. Data is valid at nominal operation condition.
Refer to the Model Specifications for nominal conditions(Power source and Ambient temperature, etc)
3. Sound level can be increased in static pressure mode or used air guide.
4. Sound level will vary depending on a range of factors such as the construction (acoustic absorption coefficient).
5. Reference acoustic intensity 0dB = 10E-6μW/m²
6. Sound power level is measured on the rated condition in the semi-anechoic rooms by ISO 9614 standard.
Therefore, these values can be increased owing to ambient conditions during operation.

Model	Sound Power Levels [dB(A)]	
	Cooling	Heating
ARUN040GSS0	72.0	75.0
ARUN050GSL0	72.0	75.0
ARUN050GSS0	72.0	76.0
ARUN060GSS0	72.0	77.0
ARUN040LSS0	72.0	76.0
ARUN050LSS0	72.0	76.0
ARUN060LSS0	72.0	77.0
ARUN080LSS0	78.0	81.0
ARUN100LSS0	77.0	79.0
ARUN120LSS0	78.0	82.0

ARUN040GSS0

ARUN050GSL0

ARUN050GSS0

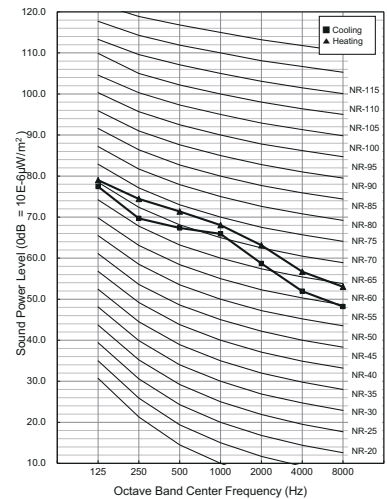
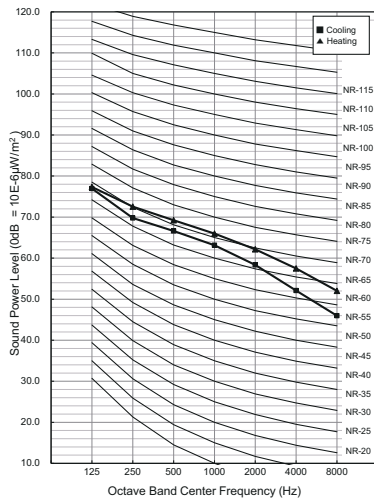
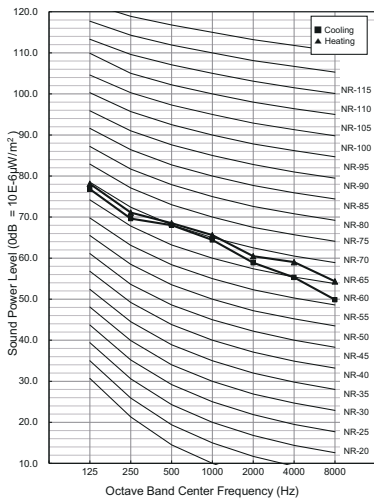

12. Sound Levels

ARUN060GSS0

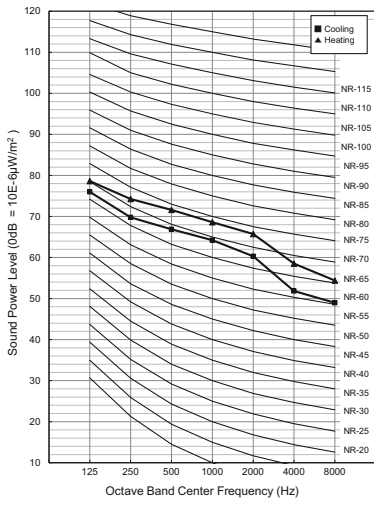

ARUN040LSS0

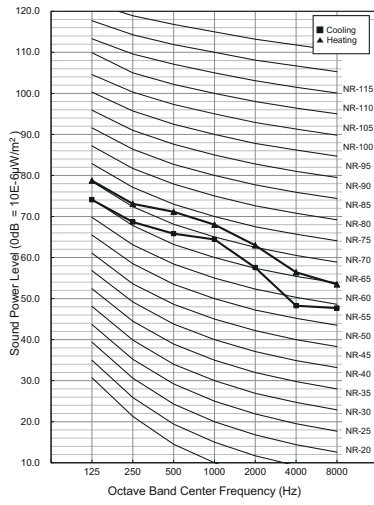

ARUN050LSS0

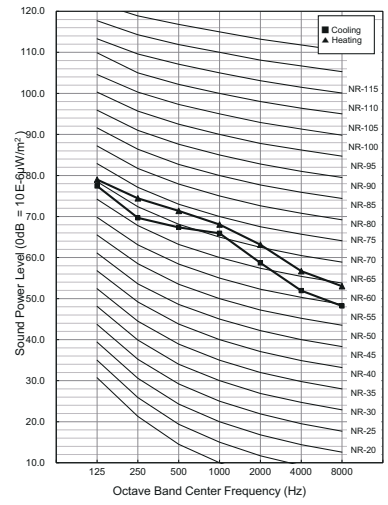

ARUN060LSS0

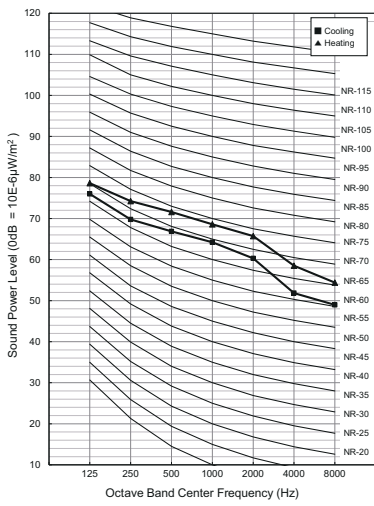

ARUN080LSS0

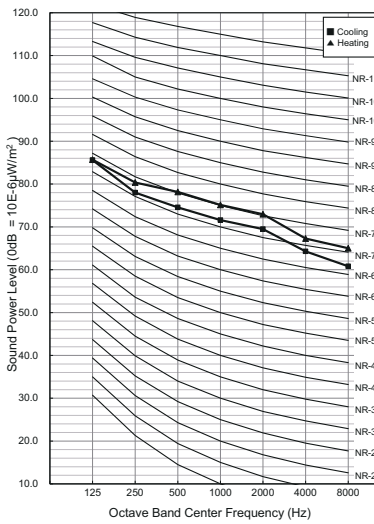

ARUN100LSS0

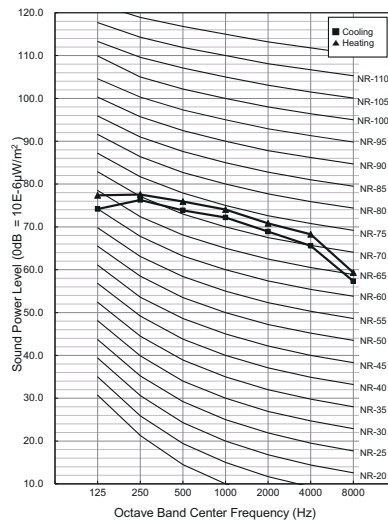

ARUN120LSS0

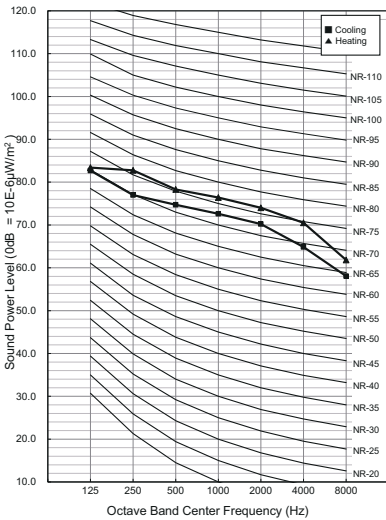

Installation of Outdoor Units

- 1. Alternative Refrigerant R410A**
- 2. Select the Best Location**
- 3. Installation Space**
- 4. Lifting Method**
- 5. Installation**
- 6. Refrigerant Piping Installation**
- 7. Refrigerant Piping System**
- 8. Electrical Wiring**

1. Alternative Refrigerant R410A

- The refrigerant R410A has the property of higher operating pressure in comparison with R22. Therefore, all materials have the characteristics of higher resisting pressure than R22 ones and this characteristic should be also considered during the installation.
R410A is an azeotrope of R32 and R125 mixed at 50:50, so the ozone depletion potential (ODP) of R410A is 0.
-

CAUTION

- The wall thickness of the piping should comply with the relevant local and national regulations for the designed pressure 3.8MPa
 - Since R410A is a mixed refrigerant, the required additional refrigerant must be charged in its liquid state. If the refrigerant is charged in its gaseous state, its composition changes and the system will not work properly.
 - Do not place the refrigerant container under the direct rays of the sun to prevent it from exploding.
 - For high-pressure refrigerant, any unapproved pipe must not be used.
 - Do not heat pipes more than necessary to prevent them from softening.
 - Be careful not to install wrongly to minimize economic loss because it is expensive in comparison with R22.
-

2. Select the Best Location

1. Select space for installing outdoor unit, which will meet the following conditions:
 - No direct thermal radiation from other heat sources
 - No possibility of annoying neighbors by noise from unit
 - No exposition to strong wind
 - With strength which bears weight of unit
 - Note that drain flows out of unit when heating
 - With space for air passage and service work shown next
 - Because of the possibility of fire, do not install unit to the space where generation, inflow, stagnation, and leakage of combustible gas is expected.
 - Avoid unit installation in a place where acidic solution and spray (sulfur) are often used.
 - Do not use unit under any special environment where oil, steam and sulfuric gas exist.
 - It is recommended to fence round the outdoor unit in order to prevent any person or animal from accessing the outdoor unit.
 - If installation site is area of heavy snowfall, then the following directions should be observed.
 - Make the foundation as high as possible.
 - Fit a snow protection hood.
2. Select installation location considering following conditions to avoid bad condition when additionally performing defrost operation.
 - Install the outdoor unit at a place well ventilated and having a lot of sunshine in case of installing the product at a place with a high humidity in winter (near beach, coast, lake, etc).
(Ex) Rooftop where sunshine always shines.
 - Performance of heating will be reduced and pre-heat time of the indoor unit may be lengthened in case of installing the outdoor unit in winter at following location:
 - Shade position with a narrow space
 - Location with much moisture in neighboring floor.
 - Location with much humidity around.
 - Location where ventilation is good.
It is recommended to install the outdoor unit at a place with a lot of sunshine as possible as.
 - Location where water gathers since the floor is not even.
3. When installing the outdoor unit in a place that is constantly exposed to a strong wind like a coast or on a high story of a building, secure a normal fan operation by using a duct or a wind shield.
 - Install the unit so that its discharge port faces to the wall of the building.
Keep a distance 500mm or more between the unit and the wall surface.
 - Supposing the wind direction during the operation season of the air conditioner, install the unit so that the discharge port is set at right angle to the wind direction.

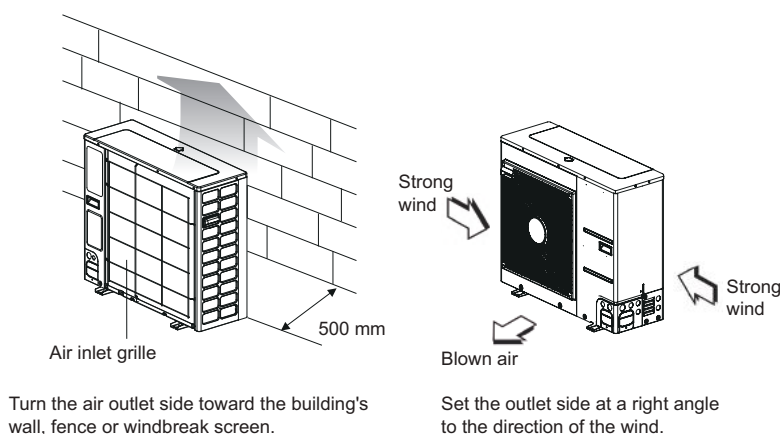

※ Outdoor unit is representative. Actual appearance of outdoor unit may be different but clearances will stay the same.

2. Select the Best Location

◆ Seasonal wind and cautions in winter

- Sufficient measures are required in a snow area or severe cold area in winter so that product can be operated well.
- Get ready for seasonal wind or snow in winter even in other areas.
- Install a suction and discharge duct not to let in snow or rain.
- Install the outdoor unit not to come in contact with snow directly. If snow piles up and freezes on the air suction hole, the system may malfunction. If it is installed at snowy area, attach the hood to the system.
- The raised support platform must be high enough to allow the unit to remain above possible snow drifts, and must be higher than the maximum anticipated snowfall for the location

Note

1. Don't install the suction hole and discharge hole of the Outdoor unit facing the seasonal wind.
-

3. Installation Space

- The following values are the least space for installation.
If any service area is needed for service according to field circumstance, obtain enough service space.
- The unit of values is mm.

3.1 Individual Installation

■ In case of obstacles on the suction side

1. Stand alone installation

[Unit:mm]

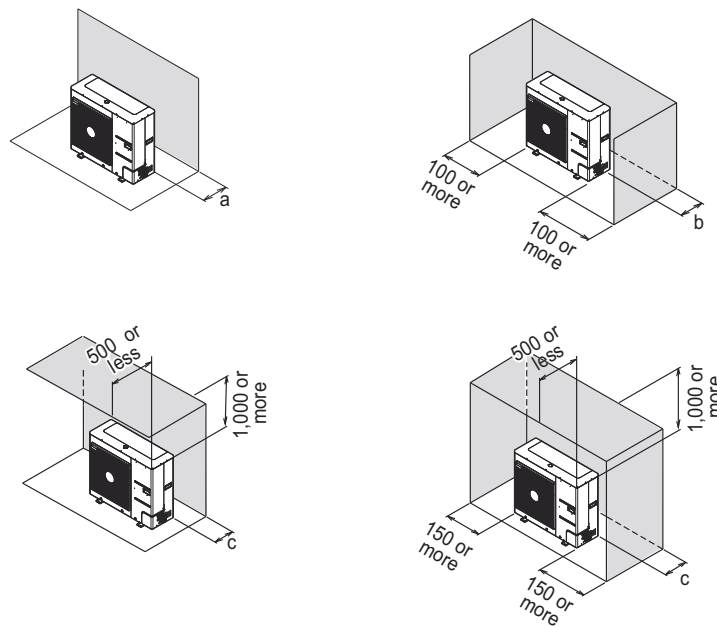

2. Collective installation

[Unit:mm]

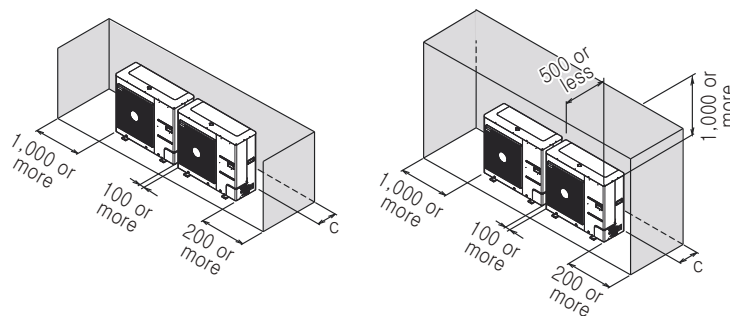

Chassis code	U4 / U3 Chassis	U7 Chassis
a	100 or more	200 or more
b	100 or more	300 or more
c	300 or more	350 or more

Note

- Depending on the sales region or product type, external appearance and applicability of each “Chassis” might be varied.

3. Installation Space

■ In case of obstacles on the discharge side

1. Stand alone installation

[Unit:mm]

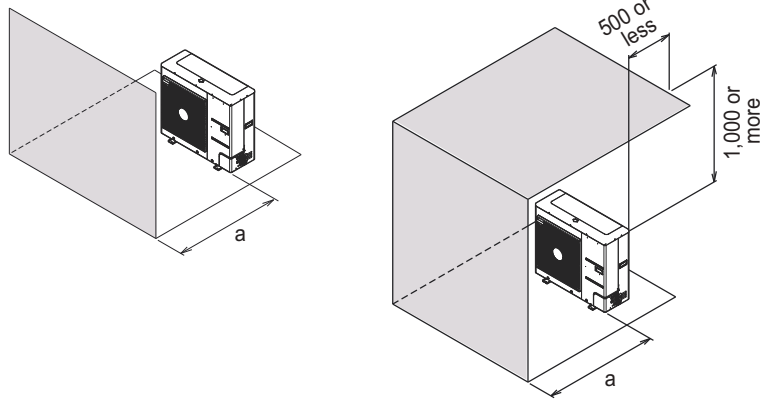

2. Collective installation

[Unit:mm]

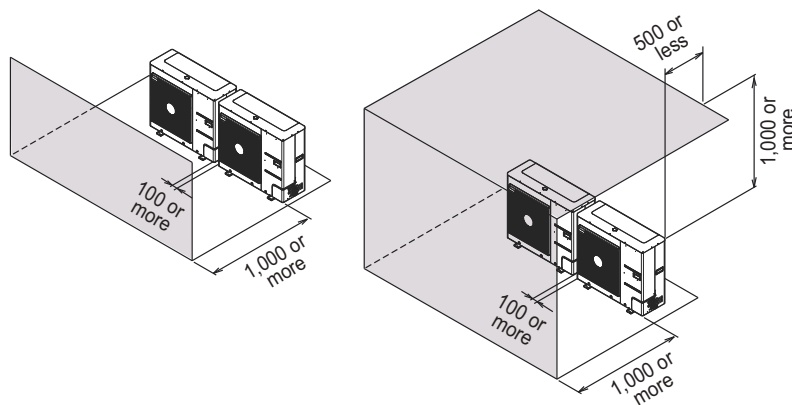

Chassis code	U4 / U3 Chassis	U7 Chassis
a	500 or more	700 or more

Note

- Depending on the sales region or product type, external appearance and applicability of each “Chassis” might be varied.

3. Installation Space

■ In case of obstacles on the suction and the discharge side

- Obstacle height of discharge side is higher than the unit

1. Stand alone installation

[Unit:mm]

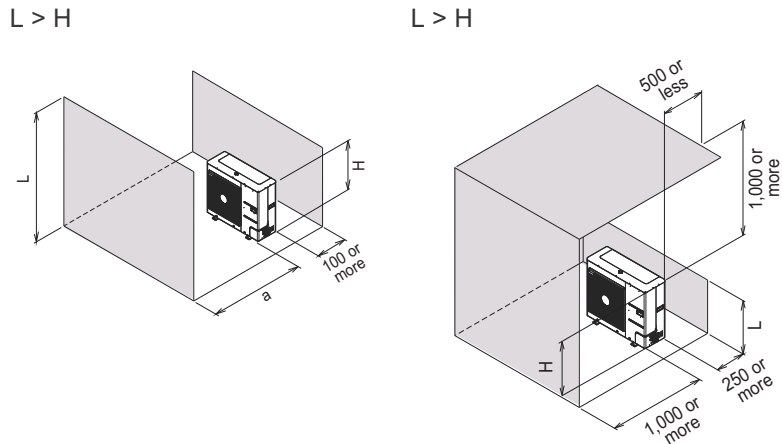

2. Collective installation

[Unit:mm]

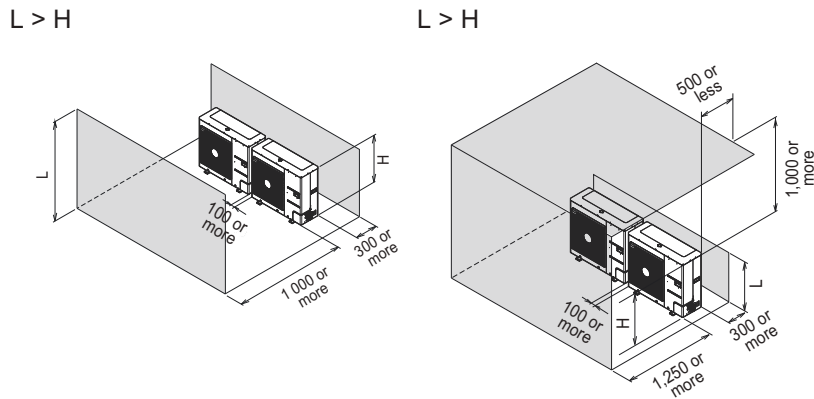

Chassis code	U4 / U3 Chassis	U7 Chassis
a	500 or more	700 or more
Note		
• Depending on the sales region or product type, external appearance and applicability of each "Chassis" might be varied.		

3. Installation Space

- Obstacle height of discharge side is lower than the unit

1. Stand alone installation

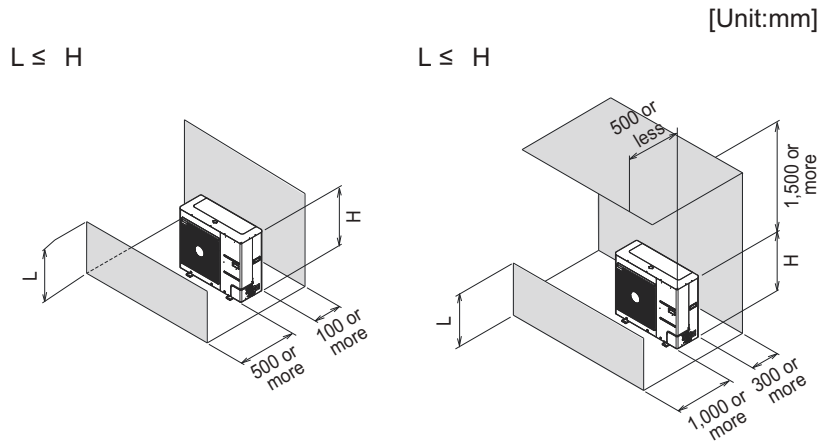

2. Collective installation

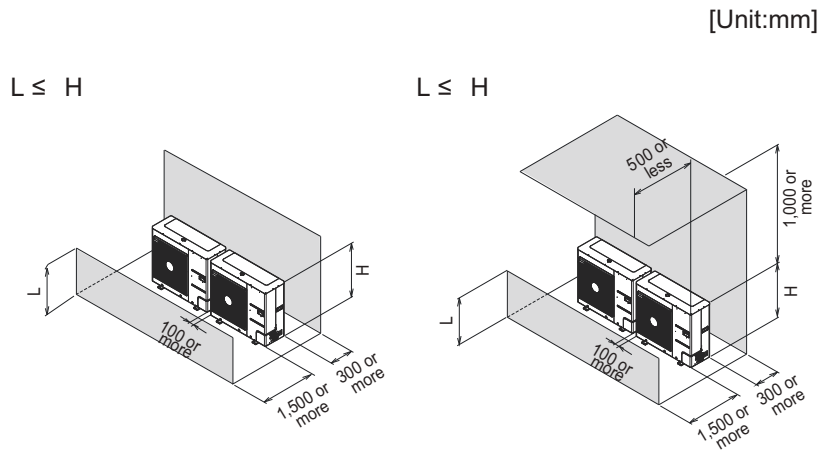

3. Installation Space

3.2 Collective / continuous installation

Space required for collective installation and continuous installation: When installing several units, leave space between each block as shown below considering passage for air and people.

■ One row of stand alone installation

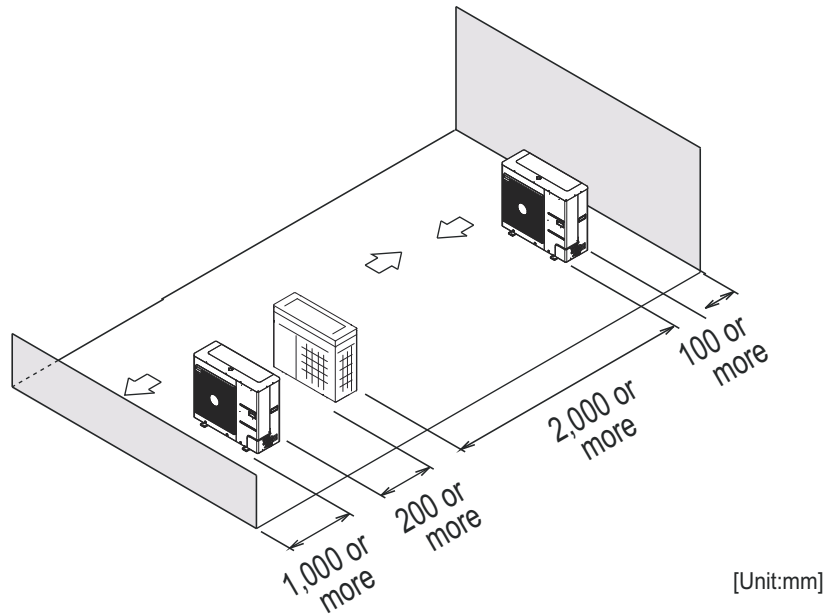

■ Rows of collective installation (2 or more)

- L should be smaller than H

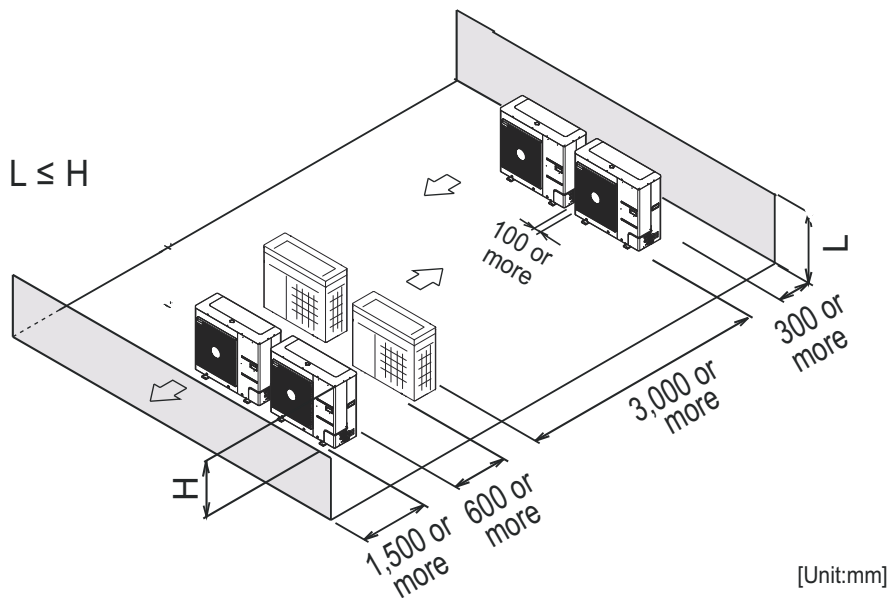

4. Lifting Method

- When carrying the suspended, unit pass the ropes between legs of base panel under the unit.
- Always lift the unit with ropes attached at four points so that impact is not applied to the unit.
- Attach the ropes to the unit at an angle of 40° or less.
- Use only accessories and parts which are of the designated specification when installing.

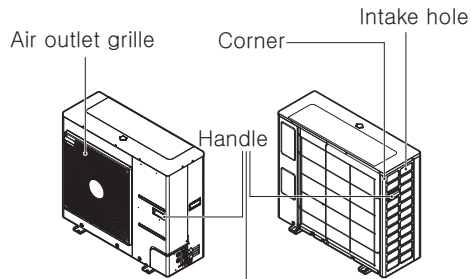

Always hold the unit by the corners, as holding it by the side intake holes on the casing may cause them to deform.

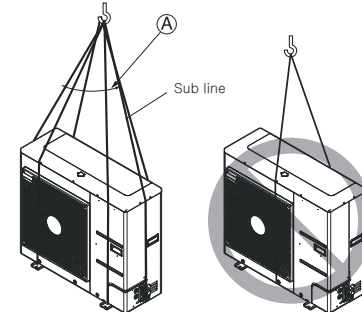

Ⓐ 40° or less

⚠ WARNING

⚠ CAUTION

Be very careful while carrying the product.

- Do not have only one person carry product if it is more than 20 kg.
- PP bands are used to pack some products. Do not use them as a mean for transportation because they are dangerous.
- Do not touch heat exchanger fins with your bare hands. Otherwise you may get a cut in your hands.
- Tear plastic packaging bag and scrap it so that children cannot play with it Otherwise plastic packaging bag may suffocate children to death.
- When carrying in Outdoor unit, be sure to support it at four points. Carrying in and lifting with 3-point support may make Outdoor unit unstable, resulting in a fall.

5. Installation

- Install at places where it can endure the weight and vibration/noise of the outdoor unit.
- The outdoor unit supports at the bottom shall have width of at least 100mm under the Unit's legs before being fixed.
- The outdoor unit supports should have minimum height of 200mm.
- Anchor bolts must be inserted at least 75mm.

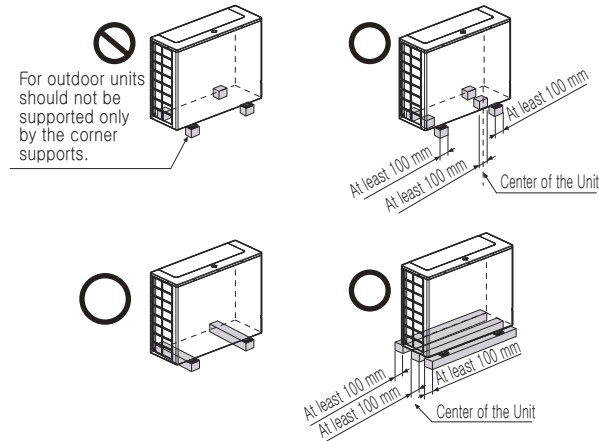

5.1 The location of the Anchor bolts

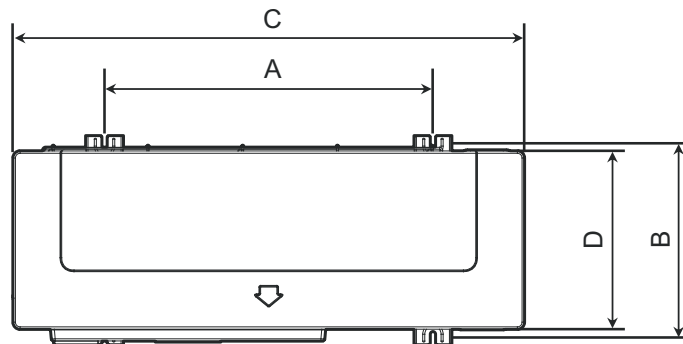

Chassis	A x B [Unit : mm]	C x D [Unit : mm]
U4 / U3	620 x 360	950 x 330
U7	700 X 401	1,090 x 380

Note

- Depending on the sales region or product type, external appearance and applicability of each "Chassis" might be varied.

5. Installation

5.2 Foundation for Installation

- Fix the unit tightly with bolts as shown below so that unit will not fall down due to earthquake or gust.
- Use the H-beam support as a base support
- Noise and vibration may occur from the floor or wall since vibration is transferred through the installation part depending on installation status. Thus, use anti-vibration materials (cushion pad) fully (The base pad shall be more than 200mm).

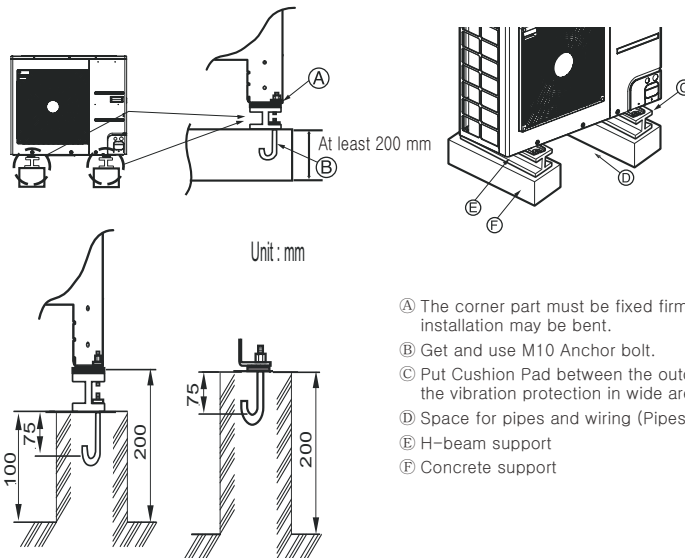

- Ⓐ The corner part must be fixed firmly. Otherwise, the support for the installation may be bent.
- Ⓑ Get and use M10 Anchor bolt.
- Ⓒ Put Cushion Pad between the outdoor unit and ground support for the vibration protection in wide area.
- Ⓓ Space for pipes and wiring (Pipes and wirings for bottom side)
- Ⓔ H-beam support
- Ⓕ Concrete support

⚠ WARNING

- Install where it can sufficiently support the weight of the outdoor unit.
If the support strength is not enough, the outdoor unit may drop and hurt people.
- Install where the outdoor unit may not fall in strong wind or earthquake.
If there is a fault in the supporting conditions, the outdoor unit may fall and hurt people.
- Please take extra cautions on the supporting strength of the ground, water outlet treatment (treatment of the water flowing out of the outdoor unit in operation), and the passages of the pipe and wiring, when making the ground support.
- Do not use tube or pipe for water outlet in the Base pan. Use drainage instead for water outlet. The tube or pipe may freeze and the water may not be drained.

⚠ WARNING

- Be sure to remove the Pallet (Wood Support) of the bottom side of the outdoor unit Base Pan before fixing the bolt. It may cause the unstable state of the outdoor settlement, and may cause freezing of the heat exchanger resulting in abnormal operations.
- Be sure to remove the Pallet (Wood Support) of the bottom side of the outdoor unit before welding. Not removing Pallet (Wood Support) causes hazard of fire during welding.

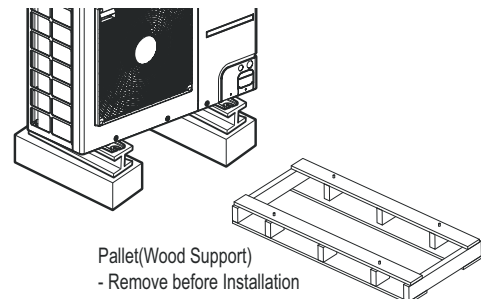

6. Refrigerant Piping Installation

6.1 Precautions on Pipe connection / Valve operation

Pipe connection is done by connecting from the end of the pipe to the branching pipes, and the refrigerant pipe coming out of the outdoor unit is divided at the end to connect to each indoor unit. Flare connection for the indoor unit, and welding connection for the outdoor pipe and the branching parts.

- Use hexagonal wrench to open/close the valve.

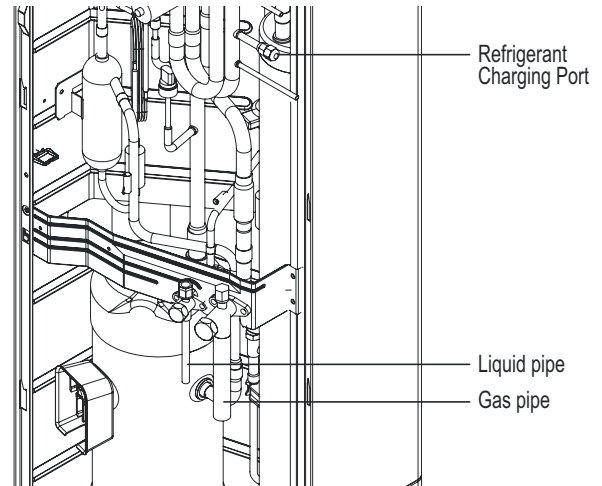

⚠ WARNING

- Always careful not to leak the refrigerant during welding.
- The refrigerant generates poisonous gas harmful to human body if combusted.
- Do not perform welding in a closed space.
- Be sure to close the cap of the service port to prevent gas leakage after the work.

⚠ CAUTION

Please block the pipe knock outs of the front and side panels after installing the pipes.
(Animals or foreign objects may be brought in to damage wires.)

7. Refrigerant Piping System

7.1 Pipe Connection Method between outdoor unit / indoor unit

7.1.1 Standard Model (ARUN****SS0)

Y branch method

- Ⓐ: Outdoor Unit
- Ⓑ: 1st branch (Y branch)
- Ⓓ: Indoor Units

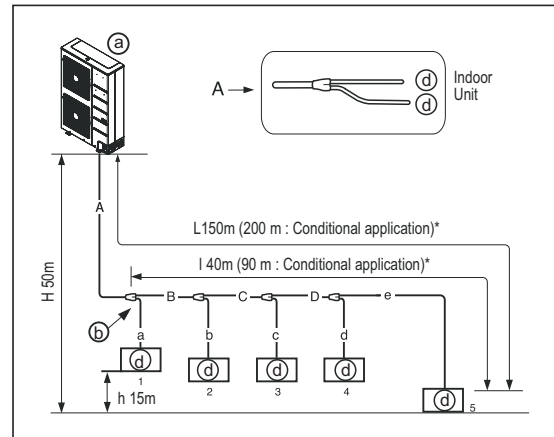

Combination of Y branch / header method

- Ⓐ: Outdoor Unit
- Ⓑ: 1st branch (Y branch)
- Ⓒ: Y branch
- Ⓓ: Indoor Units
- Ⓔ: Header
- Ⓕ: Sealed piping

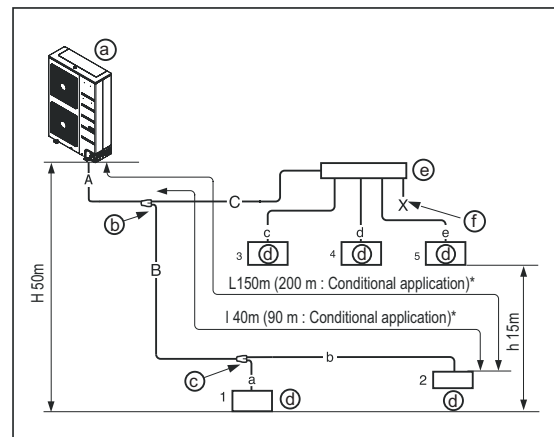

Header method

- Ⓐ: Outdoor Unit
- Ⓓ: Indoor Units
- Ⓔ: Header
- Ⓕ: Sealed piping

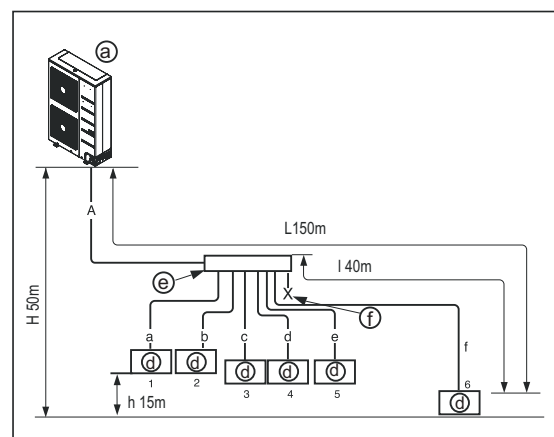

⚠ WARNING

- Branch pipe can not be used after header.
- Pipe length after header branching
 - It is recommended that difference in length of the pipes connected to the indoor units (a~f) is minimized. Performance difference between indoor units may occur.
 - Indoor units should be installed at lower position than the header.

7. Refrigerant Piping System

7.1.2 Compact Model (ARUN****SL0)

Y branch method

- Ⓐ: Outdoor Unit
- Ⓑ: 1st branch (Y branch)
- Ⓓ: Indoor Units

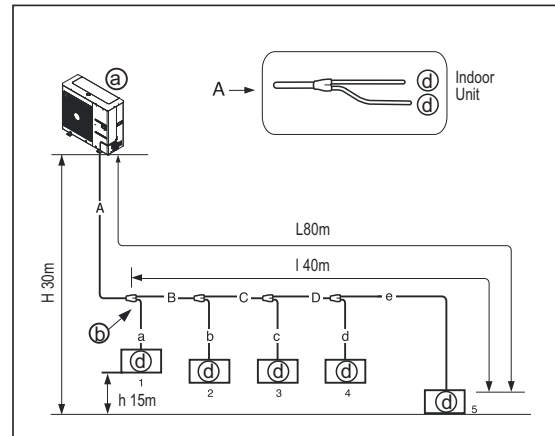

Combination of Y branch / header method

- Ⓐ: Outdoor Unit
- Ⓑ: 1st branch (Y branch)
- Ⓒ: Y branch
- Ⓓ: Indoor Units
- Ⓔ: Header
- Ⓕ: Sealed piping

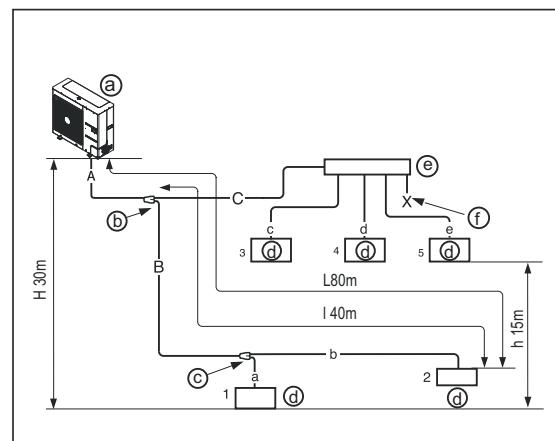

Header method

- Ⓐ: Outdoor Unit
- Ⓓ: Indoor Units
- Ⓔ: Header
- Ⓕ: Sealed piping

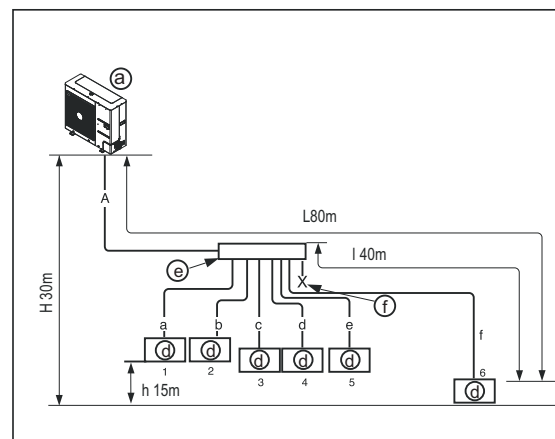

⚠ WARNING

- Branch pipe can not be used after header.
- Pipe length after header branching
 - It is recommended that difference in length of the pipes connected to the indoor units (a~f) is minimized. Performance difference between indoor units may occur.
 - Indoor units should be installed at lower position than the header.

7. Refrigerant Piping System

■ Limits of pipe length and difference in height

◆ **Standard Model (ARUN****SS0)**

Connection method		Y branch only	Combination of Y branch / header	Header only
Max. pipe length	Longest pipe length (L) : between Outdoor Unit ↔ Indoor Unit	$A+B+C+D+e \leq 150m(200m^{**})$	$A+B+b \leq 150m(200m^{**})$ $A+C+e \leq 150m(200m^{**})$	$A+f \leq 150 m$
	Longest pipe equivalent length* (L) : between Outdoor Unit ↔ Indoor Unit	175m(225m ^{**})	175m(225m ^{**})	175m
	Longest pipe length after 1st branch (ℓ)	40m (90 m ^{**})	40m (90 m ^{**})	40m
	Total pipe length	300 m	300m	300m
Max. difference in height	Difference in height (H) : between Outdoor Unit ↔ Indoor Unit	50m	50m	50m
	Difference in height (h) : between Indoor Unit ↔ Indoor Unit	15m	15m	15m

◆ **Compact Model (ARUN****SL0)**

Connection method		Y branch only	Combination of Y branch / header	Header only
Max. pipe length	Longest pipe length (L) : between Outdoor Unit ↔ Indoor Unit	$A+B+C+D+e \leq 80m$	$A+B+b \leq 80 m$ $A+C+e \leq 80 m$	$A+f \leq 80 m$
	Longest pipe equivalent length* (L) : between Outdoor Unit ↔ Indoor Unit	100 m	100 m	100 m
	Longest pipe length after 1st branch (ℓ)	40 m	40 m	40 m
	Total pipe length	150 m	150 m	150 m
Max. difference in height	Difference in height (H) : between Outdoor Unit ↔ Indoor Unit	30 m	30 m	30 m
	Difference in height (h) : between Indoor Unit ↔ Indoor Unit	15 m	15 m	15 m

Note

- * : Assume equivalent piping length of Y branch to be 0.5m, that of header to be 1m, calculation purpose.
- ** : To apply Conditional Application

WARNING

When the below condition is satisfied, the diameter of main pipe (A) must be increased according to below table.

- The equivalent length between outdoor unit and the farthest indoor unit is 90m or more (Liquid and Gas pipes are increased)
- * Compact models are not applied.

7. Refrigerant Piping System

■ Refrigerant pipe diameter from outdoor unit to first branch. (A)

Upward Outdoor unit total capacity	Standard Pipe Diameter		Increased Pipe Diameter	
			When equivalent pipe length is 90m or more from ODU to farthest IDU	
HP	Liquid pipe [mm(inch)]	Gas pipe [mm(inch)]	Liquid pipe [mm(inch)]	Gas pipe [mm(inch)]
3, 4	Ø 9.52(3/8)	Ø 15.88(5/8)	Ø 12.7(1/2)	Ø 19.05(3/4)
5	Ø 9.52(3/8)	Ø 15.88(5/8)	Ø 12.7(1/2)	Ø 19.05(3/4)
6	Ø 9.52(3/8)	Ø 19.05(3/4)	Ø 12.7(1/2)	Ø 22.2(7/8)
8	Ø 9.52(3/8)	Ø 19.05(3/4)	Ø 12.7(1/2)	Ø 22.2(7/8)
10	Ø 9.52(3/8)	Ø 22.2(7/8)	Ø 12.7(1/2)	Ø 25.4(1) *
12, 14	Ø 12.7(1/2)	Ø 28.58(1-1/8)	Ø 15.88(5/8)	not increased

Note

- * : If available on site, select pipe size from the pipe diameter table according to capacity. Otherwise it doesn't need to be increased.
- Model line up could be different in accordance with target region.

■ Refrigerant pipe diameter from branch to branch (B,C,D)

Downward Indoor Unit total capacity [kW(Btu/h)]	Liquid pipe [mm(inch)]	Gas pipe [mm(inch)]
≤ 5.6(19,100)	Ø6.35(1/4)	Ø12.7(1/2)
< 16.0(54,600)	Ø9.52(3/8)	Ø15.88(5/8)
< 22.4(76,400)	Ø9.52(3/8)	Ø19.05(3/4)
< 33.6(114,700)	Ø9.52(3/8)	Ø22.2(7/8)
< 50.4(172,000)	Ø12.7(1/2)	Ø28.58(1-1/8)
< 67.2(229,300)	Ø15.88(5/8)	Ø28.58(1-1/8)

■ Conditional Application (only for Y Branch method)

If the below conditions are satisfied, limit of longest pipe length after 1st branch(ℓ) could be extended by 40m → 90m.

Note

1. Pipe diameter Size Up

Pipe diameter(Liquid/Gas pipes) between 1st branch ↔ last branch(B,C,D) is increased by on step.

If the pipe diameter of B,C,D is same as A, it is not necessary.

: Ø 6.35 → Ø 9.52 → Ø 12.7 → Ø 15.88 → Ø 19.05 → Ø 22.2 → ...

If available on site, select pipe size from the pipe diameter table according to capacity. Otherwise it doesn't need to be increased.

2. Correction for calculating the total pipe length

When calculating total pipe length, pipe B,C,D length should be calculated twice.

: $A+Bx2+Cx2+Dx2+a+b+c+d+e \leq 300$ m

3. Indoor unit pipe length

Length of pipe from each indoor unit to the closest branch (a,b,c,d,e) ≤ 40 m.

4. Difference in length between outdoor unit and the farthest or closest indoor unit

[Length of pipe from outdoor unit to the farthest indoor unit 5 (A+B+C+D+e)]

- [Length of pipe from outdoor unit to the closest indoor unit 1 (A+a)] ≤ 40 m

7. Refrigerant Piping System

7.2 Indoor Unit Connection

◆ Indoor Unit connecting pipe from branch (a,b,c,d,e,f)

Indoor Unit capacity [kW(Btu/h)]	Liquid pipe [mm(inch)]	Gas pipe [mm(inch)]
≤ 5.6(19,100)	Ø6.35(1/4)	Ø12.7(1/2)
< 16.0(54,600)	Ø9.52(3/8)	Ø15.88(5/8)
< 22.4(76,400)	Ø9.52(3/8)	Ø19.05(3/4)
≤ 28.0(95,900)	Ø9.52(3/8)	Ø22.2(7/8)

⚠ CAUTION

- Bending radius should be at least twice the diameter of the pipe.
- Bend pipe after 500mm or more from branch(or header).
Do not bend U type.
It may cause Performance unsatisfactory or noise.

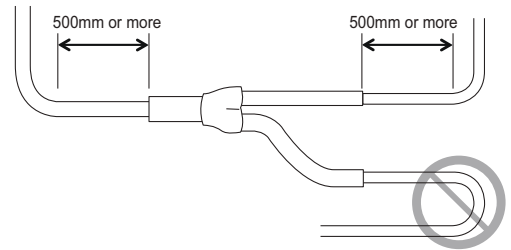

7.3 The amount of Refrigerant

The calculation of the additional charge should take into account the length of pipe and CF(correction Factor) value of indoor unit.

Additional charge(kg)	=	Total liquid pipe : Ø25.4 mm	×	0.480(kg/m)
	+	Total liquid pipe : Ø22.2 mm	×	0.354(kg/m)
	+	Total liquid pipe : Ø19.05 mm	×	0.266(kg/m)
	+	Total liquid pipe : Ø15.88 mm	×	0.173(kg/m)
	+	Total liquid pipe : Ø12.7 mm	×	0.118(kg/m)
	+	Total liquid pipe : Ø9.52 mm	×	0.061(kg/m)
	+	Total liquid pipe : Ø6.35 mm	×	0.022(kg/m)
	+	Number of installed HR units(2,3,4port)	×	0.500(kg)
	+	Number of installed HR units(6,8port)	×	1.000(kg)
	+	CF value of indoor unit(kg/EA)		

Note

For CF value (additional refrigerant) table of indoor units, please refer to PDB of indoor unit.

7. Refrigerant Piping System

7.4 Distribution Method

1. Line Distribution

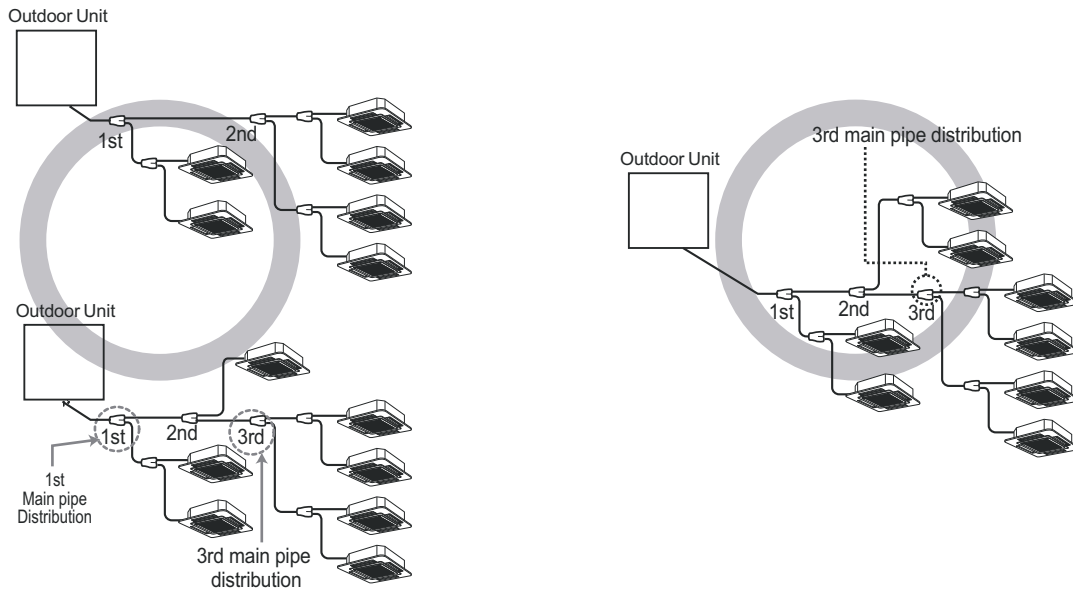

2. Vertical Distribution

Ensure that the branch pipes are attached vertically.

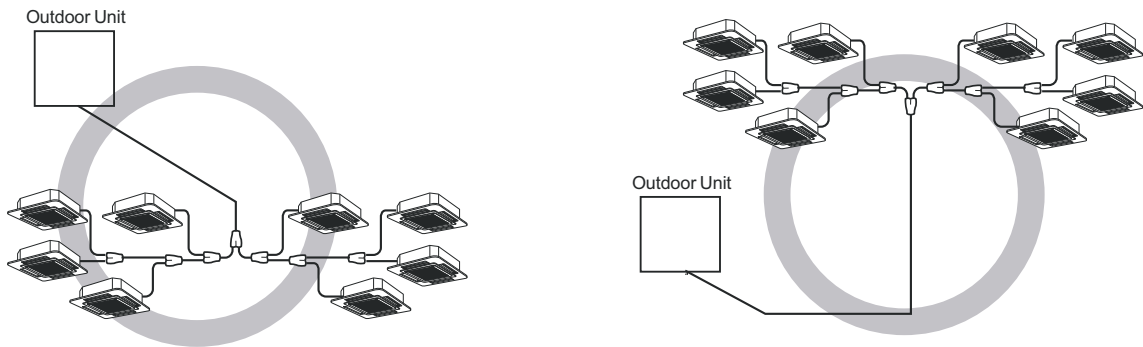

3. The others

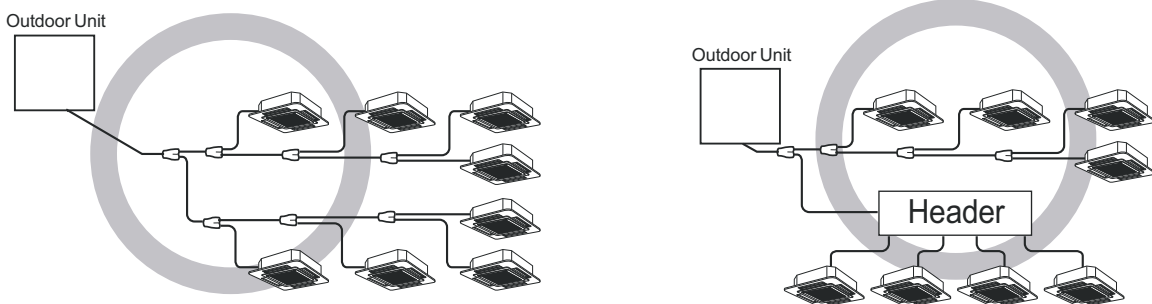

7. Refrigerant Piping System

7.5 Selection of Y Branch and Header

7.5.1 Y Branch

■ Heat Pump System

Models	Gas pipe [unit:mm]	Liquid pipe [unit:mm]
ARBLN01621		
ARBLN03321		
ARBLN07121		
ARBLN14521		
ARBLN23220		

7. Refrigerant Piping System

7.5.2 Header

Models	Gas pipe [Unit:mm]	Liquid pipe [Unit:mm]
4 branch ARBL054		
7 branch ARBL057		
4 branch ARBL104		
7 branch ARBL107		
10 branch ARBL1010		
10 branch ARBL2010		

8. Electrical Wiring

8.1 Electrical Wiring

8.1.1 Caution

1. Follow ordinance of your governmental organization for technical standard related to electrical equipment, wiring regulations and guidance of each electric power company.

⚠ WARNING

Be sure to have authorized electrical engineers do the electric work using special circuits in accordance with regulations and this installation manual. If power supply circuit has a lack of capacity or electric work deficiency, it may cause an electric shock or fire.

2. Install the Outdoor Unit communication line away from the power source wiring so that it is not affected by electric noise from the power source. (Do not run it through the same conduit.)
3. Be sure to provide designated grounding work to Outdoor Unit.

⚠ CAUTION

Be sure to correct the outdoor unit to earth. Do not connect earth line to any gas pipe, liquid pipe, lightning rod or telephone earth line. If earth is incomplete, it may cause an electric shock.

4. Give some allowance to wiring for electrical part box of Indoor and Outdoor Units, because the box is sometimes removed at the time of service work.
5. Never connect the main power source to terminal block of communication line. If connected, electrical parts will be burnt out.
6. Use 2-core shield cable for communication line. (○ mark in the figure below) If communication lines of different systems are wired with the same multiplecore cable, the resultant poor transmitting and receiving will cause erroneous operations. (⊗ mark in the figure below)
7. Only the communication line specified should be connected to the terminal block for Outdoor Unit communication.

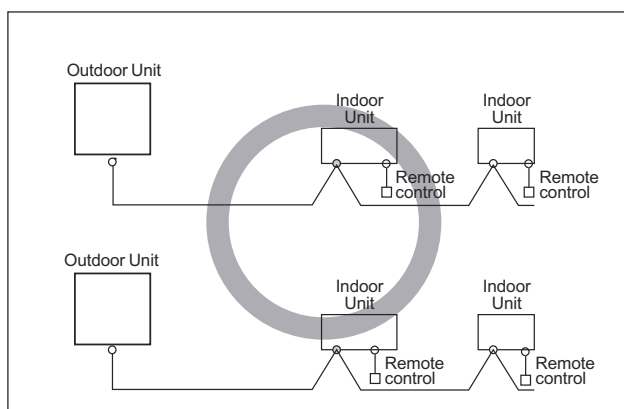

2-Core Shield Cable

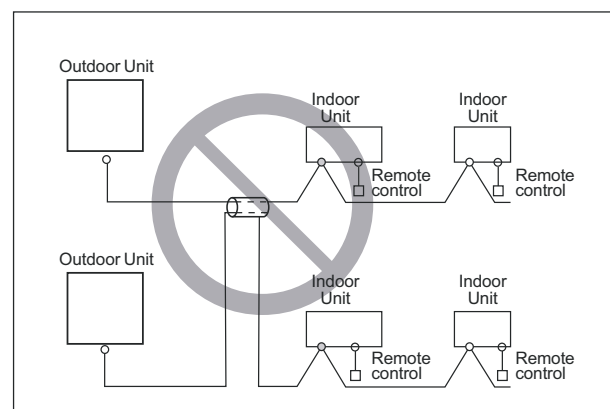

Multi-Core Cable

⚠ CAUTION

- This product have reversed phase protection detector that only works when the power is turned on. If there exists black out or the power goes on and off which the product is operating, attach a reversed

8. Electrical Wiring

phase protection circuit locally. running the product in reversed phase may break the compressor and other parts.

- Use the 2-core shield cables for communication lines. Never use them together with power cables.
- The conductive shielding layer of cable should be grounded to the metal part of both units.
- Never use multi-core cable
- As this unit is equipped with an inverter, to install a phase leading capacitor not only will deteriorate power factor improvement effect, but also may cause capacitor abnormal heating. Therefore, never install a phase leading capacitor.
- Make sure that the power unbalance ratio is not greater than 2%. If it is greater, the unit's lifespan will be reduced.
- Introducing with a missing N-phase or with a mistaken N-phase will break the equipment.

■ Precautions when laying power wiring

Use round pressure terminals for connections to the power terminal block.

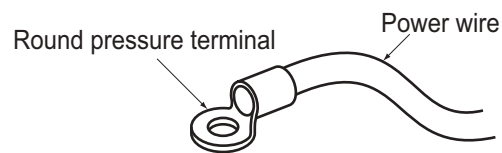

When none are available, follow the instructions below.

- Do not connect wiring of different thicknesses to the power terminal block. (Slack in the power wiring may cause abnormal heat.)
- When connecting wiring which is the same thickness, do as shown in the figure below.

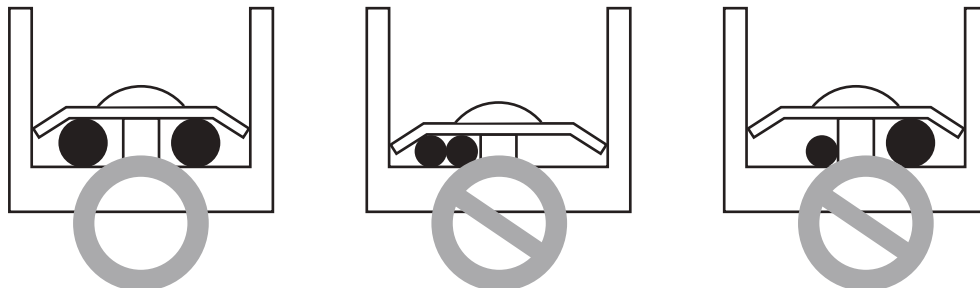

- For wiring, use the designated power wire and connect firmly, then secure to prevent outside pressure being exerted on the terminal block.
- Use an appropriate screwdriver for tightening the terminal screws. A screwdriver with a small head will strip the head and make proper tightening impossible.
- Over-tightening the terminal screws may break them.

⚠ CAUTION

When the 400 volt power supply is applied to "N" phase by mistake, replace inverter PCB and transformer in control box.

8.1.2 Communication and Power Lines

1. Communication cable

- Types: shielding cable
- Cross section: 1.0~1.5mm²
- Maximum allowable temperature: 60°C
- Maximum allowable cable length: under 300m

2. Remote control cable

8. Electrical Wiring

- Types : 3-core cable

3. Central control cable

Product type	Cable type	Diameter
ACP	2-core wire (shielding wire)	1.0~1.5mm ²
AC Smart	2-core wire (shielding wire)	1.0~1.5mm ²
AC Ez	4-core wire (shielding wire)	1.0~1.5mm ²

4. Separation of communication and power lines

- If communication and power lines are run alongside each other then there is a strong likelihood of operational faults developing due to interference in the signal wiring caused by electrostatic and electromagnetic coupling.

The tables below indicates our recommendation as to appropriate spacing of communication and powerlines where these are to be run side by side

Current capacity of power line		Spacing
100V or more	10A	300mm
	50A	500mm
	100A	1,000mm
	Exceed 100A	1,500mm

Note

- The figures are based on assumed length of parallel cabling up to 100m. For length in excess of 100m the figures will have to be recalculated in direct proportion to the additional length of line involved.
- If the power supply waveform continues to exhibit some distortion the recommended spacing in the table should be increased.
 - If the cable are laid inside conduits then the following point must also be taken into account when grouping various cable together for introduction into the conduits
 - Power cable(including power supply to air conditioner) and communication cables must not be laid inside the same
 - In the same way, when grouping the power wires and communication cables should not be bunched together.

CAUTION

- If apparatus is not properly earthed then there is always a risk of electric shocks, the earthing of the apparatus must be carried out by a qualified person.
- Use a power wire pipe for the power wiring.

8. Electrical Wiring

8.2 DIP Switch Setting

8.2.1 Checking according to dip switch setting

You can check the setting values of the unit from the 7 segment LED.

The dip switch setting should be changed when the power is OFF.

8.2.2 Checking the setting of the unit

The number is sequentially appeared at the 7 segment in 5 seconds after applying the power. This number represents the setting condition.

- Initial display order

Order	No	Mean
①	4~12	Model capacity
②	1	Cooling only
	2	Heat pump
③	38	380V
	46	460V
	22	220V
④	1	Standard
	5	Cold temperature area
	6	Tropical

- Example) ARUN100LSS0

①	②	③	④
10	2	38	1

Note

- Example of model names could be different with model names included within this PDB.
- In accordance with the number of combined outdoor unit or target region, it could not be applied to set the order ③,④.

8. Electrical Wiring

◆ Main PCB (Standard model)

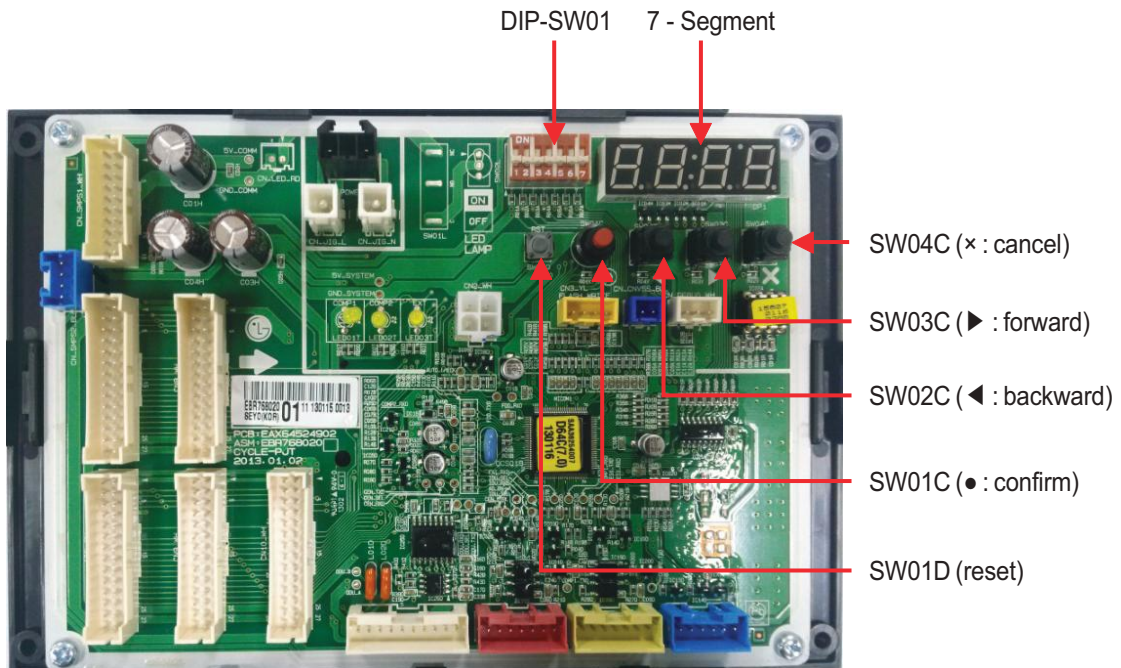

◆ Display PCB (Compact model)

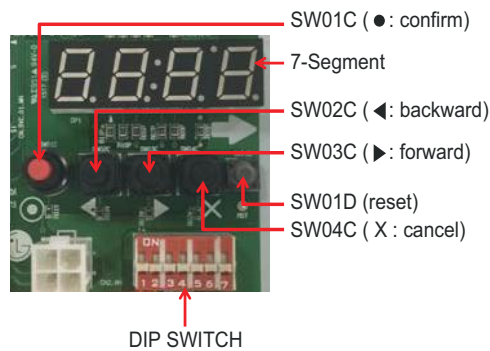

⚠ CAUTION

Product may not properly operate if the relevant DIP switch is not properly setup.

8. Electrical Wiring

8.3 Automatic Addressing

- **The address of indoor units would be set by auto addressing**

1. Wait for 3 minutes after supplying power.
2. Press RED button of the outdoor units for 5 seconds. (SW01C)
3. A "88" is indicated on 7-segment LED of the outdoor unit PCB.
4. For completing addressing, 2~7 minutes are required depending on numbers of connected indoor units
5. Numbers of connected indoor units whose addressing is completed are indicated for 30 seconds on 7-segment LED of the outdoor unit PCB
6. After completing addressing, address of each indoor unit is indicated on the wired remote control display window. (CH01, CH02, CH03,, CH06 : Indicated as numbers of connected indoor units)

- ◆ **Main PCB (Standard model)**

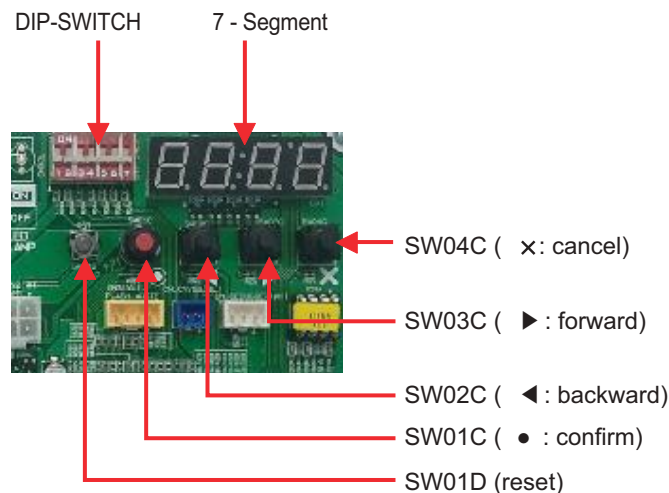

- ◆ **Display PCB (Compact model)**

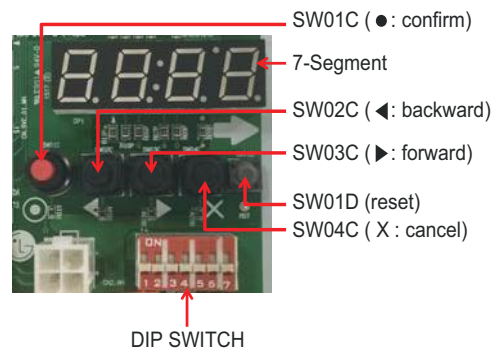

⚠ CAUTION

- In replacement of the indoor unit PCB, always perform Auto addressing setting again (At that time, please check about using Independent power module to any indoor unit.)
- If power supply is not applied to the indoor unit, operation error occur.
- Auto addressing is only possible on the Unit.
- Auto addressing has to be performed after 3 minutes to improve communication.

8. Electrical Wiring

■ The Procedure of Automatic Addressing

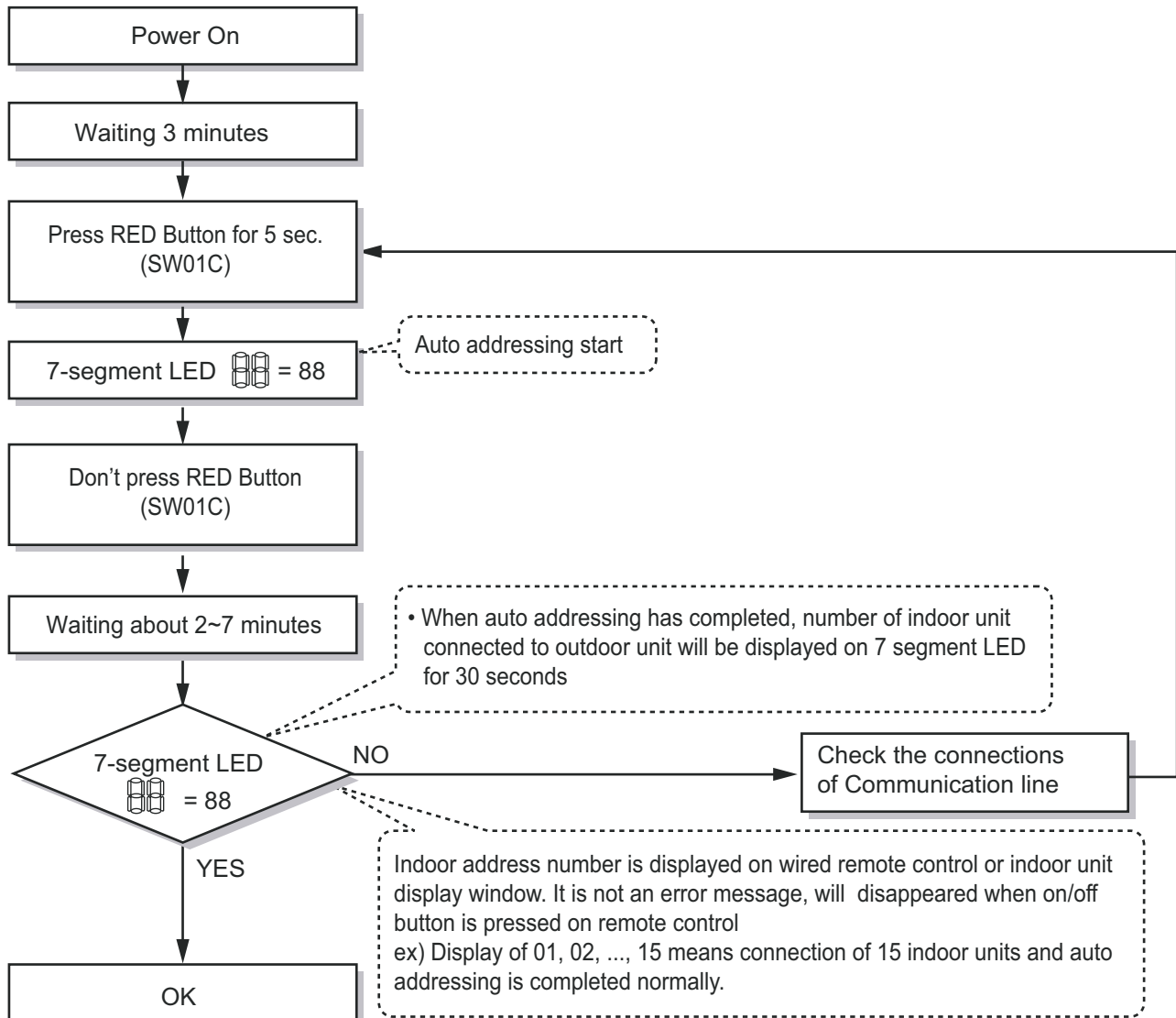

8. Electrical Wiring

8.4 Night Low Noise Function

This function makes the ODU fan operate at low RPM to reduce the fan noise of ODU at night which has low load.

◆ Night low noise function setting method

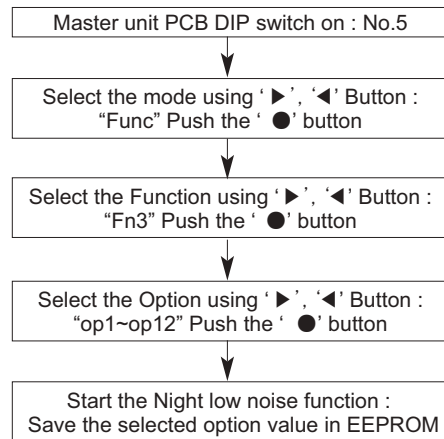

◆ Time Settings

Step	Judgment Time(Hr)	Operation Time(Hr)
op1	8	9
op2	6.5	10.5
op3	5	12
op4	8	9
op5	6.5	10.5
op6	5	12
op7	8	9
op8	6.5	10.5
op9	5	12
op10	Continuous operation	
op11	Continuous operation	
op12	Continuous operation	

⚠ CAUTION

- Request installer to set the function during installation.
- If ODU RPM changes, cooling capacity may go down.

MULTI V™ S
Outdoor Unit

Special Guide

- 1. Caution for Refrigerant Leak**
- 2. Installation Guide at the Seaside**

1. Caution For Refrigerant Leaks

The installer and system specialist shall secure safety against leakage according to local regulations or standards. The following standards may be applicable if local regulations are not available.

1.1 Introduction

The R410A refrigerant itself is harmless and nonflammable, but even if the refrigerant gas leaks into the room, the space for installing the air conditioner should be large enough that the refrigerant gas does not exceed the limit concentration.

1.1.1 Limiting concentration

Limiting concentration is the limit of Freon gas concentration where immediate measures can be taken without hurting human body when refrigerant leaks in the air. The limiting concentration shall be described in the unit of kg/m³ (Freon gas weight per unit air volume) for facilitating calculation.

Limiting concentration: 0.44kg/m³(R410A)

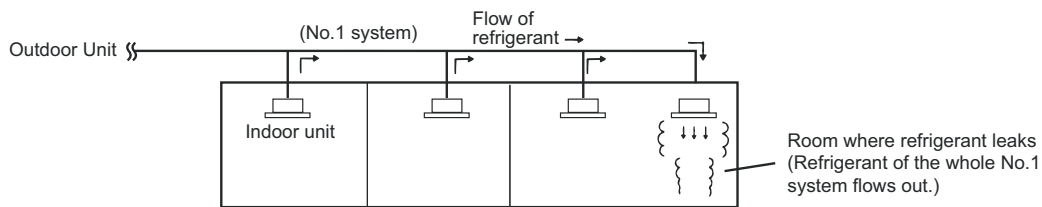

1.2 Checking procedure of limiting concentration

Check limiting concentration along following steps and take appropriate measure depending on the situation.

1.2.1 Calculate amount of all the replenished refrigerant (kg) per each refrigerant system.

◆ Calculate amount of all the replenished refrigerant (kg) per each refrigerant system.

Amount of replenished refrigerant per one outside unit system	+	Amount of additional replenished refrigerant	=	Total amount of replenished refrigerant in refrigerant facility (kg)
Amount of replenished refrigerant at factory shipment		Amount of additionally replenished refrigerant depending on piping length or piping diameter at customer		

Note

In case one refrigerant facility is divided into 2 or more refrigerant systems and each system is independent, amount of replenished refrigerant of each system shall be adopted.

1.2.2 Calculate minimum room volume

Calculate room volume by regarding a portion as one room or the smaller room.

1. Without partition

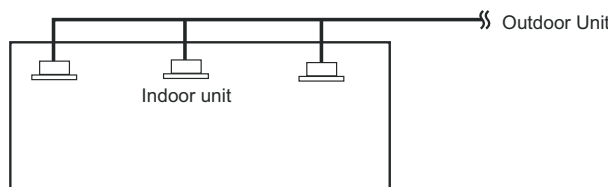

1. Caution For Refrigerant Leaks

2. With partition and with opening which serve as passage of air to adjoining room

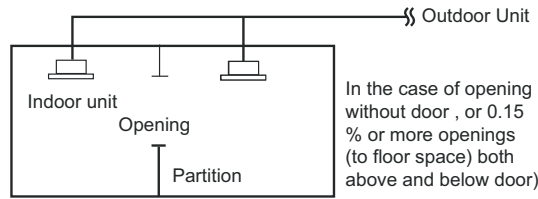

3. With partition and without opening which serve as passage of air to adjoining room

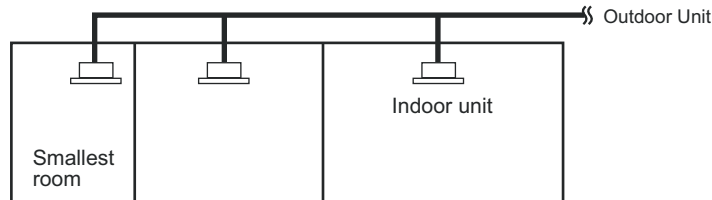

◆ Calculate refrigerant concentration

Total amount of replenished refrigerant in refrigerant facility (kg)
 Volume of smallest room where indoor unit is installed (m³)

$$= \frac{\text{Refrigerant concentration}}{\text{(R410A)}} \quad (\text{kg/m}^3)$$

In case the result of calculation exceeds the limiting concentration, perform the same calculations by shifting to the second smallest, and the third smallest rooms until at last the result is below the limiting concentration.

◆ In case the concentration exceeds the limit

When the concentration exceeds the limit, change original plan or take one of the counter measure shown below:

- **Counter measure 1**
 Provide opening for ventilation.
 Provide 0.15% or more opening to floor space both above and below door, or provide opening without door.
- **Counter measure 2**
 Provide gas leak alarm linked with mechanical ventilator.
 Reducing the outdoor refrigerant qty.

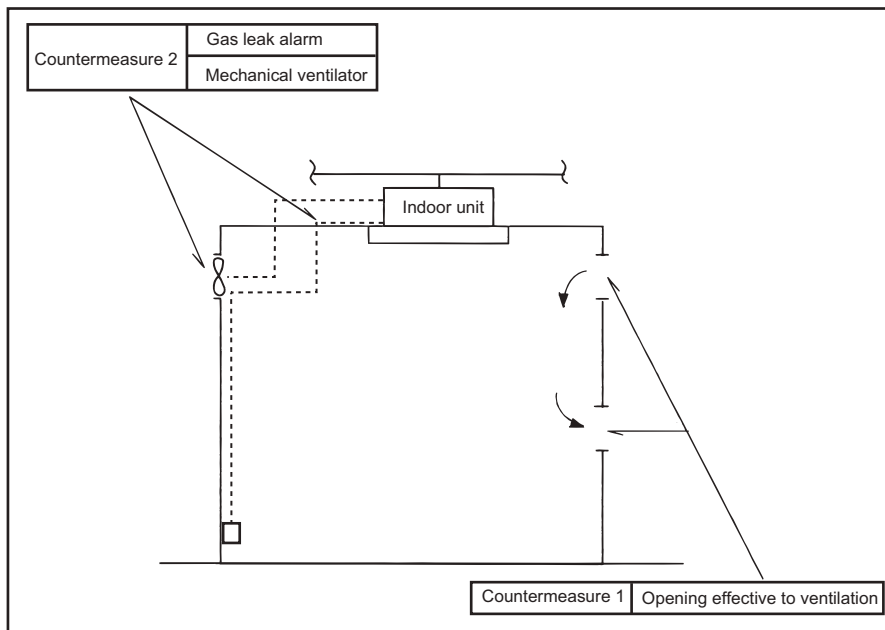

1. Caution For Refrigerant Leaks

CAUTION

Pay special attention to the place, such as a basement, etc. where refrigerant can stay, since refrigerant is heavier than air.

2. Installation Guide at the seaside

⚠ CAUTION

1. Air conditioners must not be installed in areas where corrosive gases, such as acid or alkaline gas, are present.
2. Do not install the product where it could be exposed to sea wind (salty wind) directly. As a result, the product is corroded. Corrosion, particularly on the condenser and evaporator fins, could cause product malfunction or inefficient performance.
3. If outdoor or indoor unit is installed close to the seaside, it should avoid direct exposure to the sea wind. Otherwise it needs additional corrosion resistance treatment on the heat exchanger.

2.1 Selecting the location(Outdoor Unit)

1. If the outdoor unit is to be installed close to the seaside, direct exposure to the sea wind should be avoided. Install the outdoor unit on the opposite side of the sea wind direction.

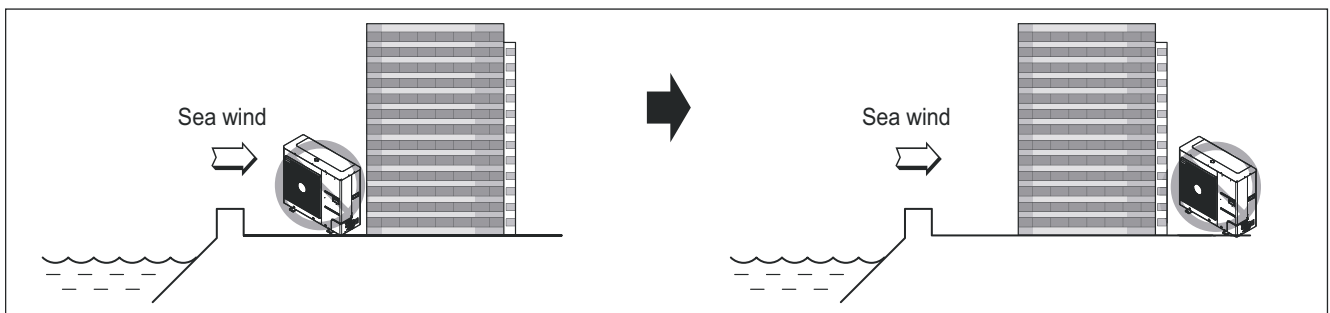

2. In case of outdoor installation on the seaside, a windbreak shield is mandatory to install not to allow exposure of the unit to the sea wind.

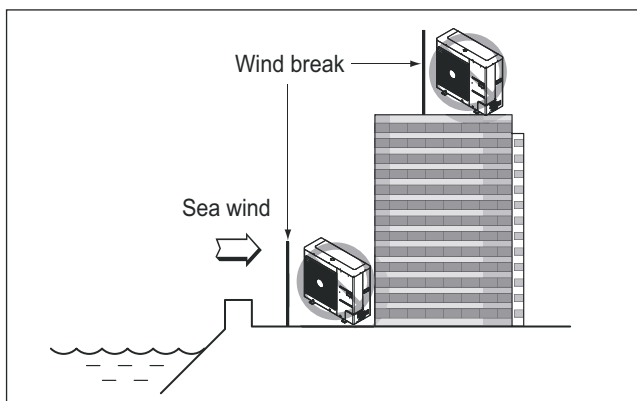

- It must be strong enough like concrete to prevent the sea wind from the sea.
- The height and width should be more than 150% of the outdoor unit.
- It must be kept more than 70 cm of space between outdoor unit and the windbreak for easy air flow.

3. Select a well-drained place.
4. Where the distance between the outdoor unit and the sea shore is more than 1km.

⚠ CAUTION

- It needs the periodic (more than once/year) cleaning of the dust or salt particles stuck on the heat exchanger by using liquid.
- LG does not guarantee in case that periodic cleaning for heat exchanger is not doing or windbreak is not installed.

2. Installation Guide at the seaside

2.2 Installation and maintenance

- Install the product where it will avoid salt water splash and beach sand as much as possible.
 - Install the machine in the direction the wind blows away from the building.
 - If you inevitably have to install the machine on by the shore, install a fence to block the wind to avoid direct contact from sea wind.
 - Be careful of the installation direction.
(The level of corrosion differs when the unit is parallel or vertical to the coast line.)
- Try to install the unit so that the particles from the sea side attached on the exterior panel can be sufficiently cleaned by the rain.
- Because the water collected within the floor of the outdoor unit significantly accelerates the corrosion process, make sure to install the unit so that water is well drained considering the inclination etc.
- For the outdoor unit installed on the sea shore, periodically wash the unit with clean water to remove any salt attached on the unit.
- Install the unit where it is well drained. Especially, secure good drainage at the floor part.
- Always repair dents caused from installation, maintenance etc.
- Periodically check the condition of the machine (Set water resistance treatment or replace parts, if necessary.)
- When you are not running the machine for a long period of time, such as during the off season, put a cover on the outdoor unit.
- Sufficiently maintain the machine well.
Also, when install the machine in a special environment, you need to take separate consideration sufficiently.



Air Solution

LG Electronics Inc, 128, Yeoui-daero,
Yeongdeungpo-gu, Seoul, Korea
(07336)
<http://partner.lge.com>

Copyright © 2021 LG Electronics Inc.
All Rights Reserved.
Printed in Korea May / 2021

The air conditioners manufactured by LG have received ISO9001 certificate for quality assurance and ISO14001 certificate for environmental management system.
The specifications, designs, and information in this brochure are subject to change without notice.