

Inverter Single Wall Mounted

LG

TOTAL HVAC

SOLUTION

PROVIDER

ENGINEERING PRODUCT DATA BOOK

Test Condition of International Standard

CLASSIFICATION			KSC 9306	ISO 5151		AHRI 210/240	AHAM (Window AC)	AS/NZS 3823.1	SASO 2663:2021	
				T1	T3				T1	T3
Cooling Capacity	Indoor	DB°C(°F)	27.0	27.0	29.0	26.7 (80)	26.7 (80)	27.0	27.0	29.0
		WB°C(°F)	19.0	19.0	19.0	19.4 (67)	19.4 (67)	19.0	19.0	19.0
	Outdoor	DB°C(°F)	35.0	35.0	46.0	35.0 (95)	35.0 (95)	35.0	35.0	46.0
		WB°C(°F)	24.0	24.0	24.0	23.9 (75)	23.9 (75)	24.0	24.0	24.0
Heating Capacity	Indoor	DB°C(°F)	20.0	20.0	20.0	21.1 (70)	21.1 (70)	20.0	20.0	20.0
		WB°C(°F)	15.0	15.0	15.0	15.6 (60)	15.6 (60)	15.0	15.0	15.0
	Outdoor	DB°C(°F)	7.0	7.0	7.0	8.3 (47)	8.3 (47)	7.0	7.0	7.0
		WB°C(°F)	6.0	6.0	6.0	6.1 (43)	6.1 (43)	6.0	6.0	6.0
Maximum Cooling Operating	Indoor	DB°C(°F)	32.0	32.0	32.0	26.7 (80)	32.2 (90)	32.0	32.0	32.0
		WB°C(°F)	23.0	23.0	13.0	19.4 (67)	22.8 (73)	23.0	23.0	13.0
	Outdoor	DB°C(°F)	43.0	43.0	52.0	46.11 (115)	43.3 (110)	43.0	43.0	52.0
		WB°C(°F)	26.0	26.0	31.0	23.9 (75)	25.6 (78)	26.0	26.0	31.0
Maximum Heating Operating	Indoor	DB°C(°F)	27.0	27.0	27.0	26.7 (80)	26.7 (80)	27.0	27.0	27.0
		WB°C(°F)	15.0	-	-	-	22.8 (73)	-	-	-
	Outdoor	DB°C(°F)	21.0	24.0	24.0	23.9 (75)	23.9 (75)	24.0	24.0	24.0
		WB°C(°F)	15.0	18.0	18.0	18.3 (65)	18.3 (65)	18.0	18.0	18.0
Enclosure Sweat / Condensate Disposal	Indoor	DB°C(°F)	27.0	27.0	27.0	26.7 (80)	26.7 (80)	27.0	27.0	27.0
		WB°C(°F)	24.0	24.0	24.0	23.9 (75)	23.9 (75)	24.0	24.0	24.0
	Outdoor	DB°C(°F)	27.0	27.0	27.0	26.7 (80)	26.7 (80)	27.0	27.0	27.0
		WB°C(°F)	24.0	24.0	24.0	23.9 (75)	23.9 (75)	24.0	24.0	24.0
Freeze-up / Low Temperature	Indoor	DB°C(°F)	21.0	21.0	21.0	19.4 (67)	21.1 (70)	21.0	21.0	21.0
		WB°C(°F)	15.0	15.0	15.0	13.9 (57)	15.6 (60)	15.0	15.0	15.0
	Outdoor	DB°C(°F)	21.0	21.0	21.0	19.4 (67)	21.1 (70)	21.0	21.0	21.0
		WB°C(°F)	15.0	-	-	13.9 (57)	15.6 (60)	-	-	-

KS : Korea Standard

ISO : International Standard Organization

AHRI : Air-Conditioning, Heating, and Refrigeration Institute

AHAM : Association of Home Appliance Manufacturers

AS/NZS : Australia and New Zealand Standard

SASO : Saudi Arabian Standards Organization

Inverter Single

Wall Mounted - 50 Hz (R32)

- 1. Models Line Up**
- 2. Nomenclature**
- 3. Specification**
- 4. Function List**
- 5. Dimensional Drawings**
- 6. Wiring Diagrams**
- 7. Refrigerant Cycle Diagrams**
- 8. Capacity Tables**
- 9. Capacity Coefficient Factor**
- 10. Operation Range**
- 11. Air Flow and Temperature Distributions (Reference Data)**
- 12. Sound Levels (Reference Data)**
- 13. Remote Controller**
- 14. Installation**

1. Models Line Up

1.1 Indoor Unit

Category	Picture	Chassis	Nominal Capacity (kBTu/h)	Model Name
Deluxe		S0	12	P12SND.NS0 (S3NM120A1H0.EC6GEEU)

1. Models Line Up

1.2 Outdoor Unit

Power Supply	Picture	Chassis	Nominal Capacity (kBtu/h)	Model Name
1 Ø , 220 ~ 240 V , 50 Hz		U12A	12	P12SND.U12A (S3UM120A1H0.EC6GEEU)

2. Nomenclature

Model Name	S	4	-	W	1	2	J	L	1	Y	1
No.	1	2	3	4	5	6	7	8	9	10	11

No.	Signification
1	Product Type S : Split
2	Refrigerant 2 : R22 3 : R32 4 : R410A
3	Supply Type - : Set N : Indoor Unit U : Outdoor Unit A : C/SKD Indoor Unit B : C/SKD Outdoor Unit M : Mock-Up
4	Model Type C : Cooling Only H : Heat Pump Q : DC Inverter Cooling Only W : DC Inverter Heat Pump M : Single and Multi Compatible
5, 6	Capacity Ex) 12 : 12,000 Btu/h
7	Indoor Unit Platform 2 : S2 H : SH 3 : S3 J : SJ 4 : S4 K : SK 5 : S5 M : SM A : SA V : SV E : SE W : SW
8	Outdoor Unit Platform A : UA3 E : UE L : UL2 P : UE1+ 2 : U24A D : UD 4 : U4

No.	Signification						
9	Look & Color						
	Platform	Look & Color	Look Name	Description			
	SA SJ SK	R	Artcool	Mirror Black			
		1	R Look	White Panel (Transparent)			
		2	Semi-R Look	White Panel (Silver Deco)			
		3	E Look	White Panel			
		4	Semi-R Look	White Panel (Red Deco)			
		5	Semi-R Look	White Panel (Gold Deco)			
		Q	E Look	White Panel (2LED)			
		P	E Look	White Panel (2LED, Matt)			
	SM	M	Moving Panel	White Panel			
	SM SM+ S2	1	R Look	White Panel (Transparent)			
		2	Semi-R Look	White Panel (Silver Deco)			
		3	E Look	White Panel			
		W	Blowkiss R	White Panel (White Deco)			
		B	Blowkiss R	White Panel (Black Deco)			
SW SH	5	E Look	White Panel				
	6	Semi-R Look	White Panel (Silver Deco)				
	Q	E Look	White Panel (2LED)				
	P	E Look	White Panel (2LED, Matt)				
SV	2	Semi-R Look	White Panel (Silver Deco)				
	3	E Look	White Panel				
S3	1	-	White Panel				
	W	-	White Panel (Lighting)				
10	Function						
	Module	Airflow	Wi-Fi	Additional Filter	Gen Mode	Function Digit	
	None	2way	<input type="checkbox"/>			A	
			<input type="checkbox"/>	<input type="checkbox"/>		3	
		4way	<input type="checkbox"/>			W	
			<input type="checkbox"/>		<input type="checkbox"/>	Q	
	Ionizer	2way	<input type="checkbox"/>			B	
			<input type="checkbox"/>	<input type="checkbox"/>		F	
		4way	<input type="checkbox"/>			V	
			<input type="checkbox"/>	<input type="checkbox"/>		4	
			<input type="checkbox"/>		<input type="checkbox"/>	R	
			<input type="checkbox"/>	<input type="checkbox"/>		Z	
			<input type="checkbox"/>	<input type="checkbox"/>	<input type="checkbox"/>	S	
			<input type="checkbox"/>	<input type="checkbox"/>	<input type="checkbox"/>	P	
	Mosquito	2way	<input type="checkbox"/>		<input type="checkbox"/>	J	
			<input type="checkbox"/>	<input type="checkbox"/>	<input type="checkbox"/>	T	
		4way	<input type="checkbox"/>		<input type="checkbox"/>		K
			<input type="checkbox"/>	<input type="checkbox"/>			E
			<input type="checkbox"/>		<input type="checkbox"/>		7
			<input type="checkbox"/>	<input type="checkbox"/>	<input type="checkbox"/>		6
<input type="checkbox"/>			<input type="checkbox"/>	<input type="checkbox"/>	<input type="checkbox"/>	2	
<input type="checkbox"/>			<input type="checkbox"/>	<input type="checkbox"/>	<input type="checkbox"/>	5	
Air Purifying	4way	<input type="checkbox"/>	<input type="checkbox"/>	<input type="checkbox"/>	8		
		<input type="checkbox"/>	<input type="checkbox"/>	<input type="checkbox"/>	N		
	4way	<input type="checkbox"/>				Y	
		<input type="checkbox"/>		<input type="checkbox"/>		C	
11	Standard Model No.						

3. Specifications

Buyer Model	Set (Indoor / Outdoor)		Unit	P12SND.SS0 (P12SND.NS0 / P12SND.U12A)		
Factory Model				S3-M120A1H0.EC6GEEU (S3NM120A1H0.EC6GEEU / S3UM120A1H0.EC6GEEU)		
Capacity	Cooling	Min ~ Rated ~ Max	kW	0.890	3.500	4.050
			Btu/h	3,038	11,950	13,828
			kJ/h	-	-	-
	Cooling (T3)	Min ~ Rated ~ Max	kW	-	-	-
			Btu/h	-	-	-
			kJ/h	-	-	-
Heating	Min ~ Rated ~ Max	kW	0.650	3.700	5.000	
		Btu/h	2,219	12,633	17,072	
		kJ/h	-	-	-	
Heating -7°C	Max	kW	-	3.600	-	
		W	-	933	1,400	
Power Input	Cooling	Min ~ Rated ~ Max	W	180	933	1,400
	Cooling (T3)	Min ~ Rated ~ Max	W	-	-	-
	Heating	Min ~ Rated ~ Max	W	180	900	1,600
Running Current	Cooling	Min ~ Rated ~ Max	A	1.50	4.30	6.10
	Cooling (T3)	Min ~ Rated ~ Max	A	-	-	-
	Heating	Min ~ Rated ~ Max	A	1.50	4.15	7.00
EER			WW	-	3.75	-
			(Btu/h)W	-	12.81	-
EER (T3)			(kJ/h)W	-	-	-
			WW	-	-	-
SEER			(Btu/h)W	-	-	-
			-	-	7.6	-
COP			WW	-	4.11	-
			(Btu/h)W	-	14.04	-
SCOP			(kJ/h)W	-	-	-
			-	-	4.6	-
P design C / P design H			kW	-	3.5 / 2.7	-
Energy Label Grade	Cooling / Heating			A++ / A++		
Annual Energy Consumption	Cooling / Heating		kWh/year	161 / 822		
Weighted EER			(Btu/h)W	-		
Power Supply			WW	-		
			∅, V, Hz	1, 220 ~ 240, 50		
Available Voltage Range			V	187 ~ 276		
Power Factor	Cooling / Heating		%	97.0 / 97.0		
Moisture Removal			l/h	1.30		
Indoor	Air Flow Rate	Cooling, SH / H / M / L	m³/min	12.7 / 10.3 / 7.6 / 4.8		
		Heating, SH / H / M / L	m³/min	13.0 / 10.3 / 7.6 / 4.8		
	Sound Pressure Level	Cooling, SH / H / M / L / SL	dB(A)	48 / 42 / 35 / 27 / 19		
		Heating, SH / H / M / L	dB(A)	48 / 42 / 35 / 27		
	Sound Power Level		dB(A)	60		
				799 x 307 x 235		
	Dimensions (W × H × D)	Net	mm	799 x 307 x 235		
		Shipping	mm	871 x 383 x 296		
Weight	Net	kg	10			
	Shipping	kg	12.2			
Exterior Color Code			-	Munsell 7.5P 9/2 (RAL 9003)		
Outdoor	Air Flow Rate	Max	m³/min	27.0		
				200 ~ 1000		
	Fan Motor Speed	Cooling, Min ~ Max	rpm	200 ~ 1000		
		Heating, Min ~ Max	rpm	500 ~ 1000		
	Sound Pressure Level	Cooling, Rated	dB(A)	48		
		Heating, Rated	dB(A)	51		
	Sound Power Level		dB(A)	60		
				717 x 495 x 230		
	Dimensions (W × H × D)	Net	mm	717 x 495 x 230		
		Shipping	mm	836 x 540 x 321		
Weight	Net	kg	25			
	Shipping	kg	26.5			
Max. Fuse Size			A	15		
Exterior Color Code			-	Munsell 9.54Y 8.34/1.31 (RAL 9001)		
Operation Range	Cooling		°C DB	-15 ~ 48		
	Heating		°C DB	-15 ~ 24		
	Heating		°C WB	-15 ~ 18		
Circuit Breaker			A	15		
Power Supply to Unit			-	Outdoor		
Power and Communication Cable			No. × mm²	4 × 1		
Piping	Size	Liquid	mm	ø 6.35		
		Gas	mm	ø 9.52		
	Connections Method	Indoor / Outdoor	-	Flared / Flared		
Drain Hose Size	O.D, I.D		mm	21.5, 16		
	Min / Standard / Max		m	3 / 7.5 / 20		
Between Indoor & Outdoor	Piping Length	No Charge	m	7.5		
	Max. Elevation Difference		m	10		
	Piping Connection Heat Insulation		-	Both liquid and gas pipes		
Note						
• - : No Relation						
• All power supply and communication cables and circuit breaker must comply with applicable local and national codes.						
• Exterior color code is approximate value.						
• It is difficult to measure air flow rate of sleep because of small values.						
• Maximum heating capacity is for heating operation without any frost.						
• Fan motor speed could vary ±20 rpm according to the operating conditions.						
• It may cause reliability, performance, noise, and vibration problem, unless meeting the range of connecting pipe length. Keep the minimum piping length by making loops, although indoor unit and outdoor unit are close.						
				• This product contains fluorinated greenhouse gases.		
				• Some specifications may be changed without notifications due to our policy of innovation.		
				• Test conditions are based on EN 14511 and EN 14825.		

3. Specifications

Buyer Model	Set (Indoor / Outdoor)		Unit	P12SND.SS0 (P12SND.NS0 / P12SND.U12A)	
Factory Model				S3-M120A1H0.EC6GEEU (S3NM120A1H0.EC6GEEU / S3UM120A1H0.EC6GEEU)	
Refrigerant	Type		-	R32	
	Pre Charge		kg	0.730	
	Additional Charge		g/m	20	
	Control		-	Electronic Expansion Valve	
	Global Warming Potential		-	675	
t-CO ₂ eq		-	0.493		
Defrost Method		-	-	Reverse Cycle	
Tool Code (Chassis)		Indoor / Outdoor	-	S0 / U12A	
Compressor	Type		-	Twin Rotary	
	Model		-	DST128MCA	
	Motor Type		-	BLDC	
	Oil Type / Maker		-	PVE (FW68D) / IDEMITSU	
	Oil Charge		cc	330	
	O.L.P. Name		-	-	
Manufacturer / Country of Origin		-	-	LG Electronics / China	
Fan (Indoor)	Type		-	Cross Flow Fan	
	Motor Output		W	30	
Fan (Outdoor)	Type		-	Propeller Fan	
	Motor Type		-	BLDC	
	Motor Output		W	43	
	Motor Insulation		-	Class E	
Motor Enclosure / Ingress Protection		-	-	TEAO / IPX4	
Heat Exchanger	Evaporator	Material, Tube / Fin		-	Cu / Al
		$(\phi \times \text{Row} \times \text{Column} \times \text{FPI} \times \text{L}) \times \text{Qty.}$		#1	$(\phi 7 \times 2 \times 16 \times 20 \times 592.4) \times 1$
		$(\phi \times \text{Row} \times \text{Column} \times \text{FPI} \times \text{L}) \times \text{Qty.}$		#2	-
		$(\phi \times \text{Row} \times \text{Column} \times \text{FPI} \times \text{L}) \times \text{Qty.}$		#3	-
		$(\phi \times \text{Row} \times \text{Column} \times \text{FPI} \times \text{L}) \times \text{Qty.}$		#4	-
	Corrosion Protection		-	-	PCM
	Fin Type		-	-	Slit
	Condenser	Material, Tube / Fin		-	Cu / Al
		$(\phi \times \text{Row} \times \text{Column} \times \text{FPI} \times \text{L}) \times \text{Qty.}$		#1	$(\phi 7 \times 2 \times 22 \times 18 \times 667) \times 1$
		$(\phi \times \text{Row} \times \text{Column} \times \text{FPI} \times \text{L}) \times \text{Qty.}$		#2	-
Corrosion Protection		-	-	Gold	
Fin Type		-	-	Corrugate	

Note

- - : No Relation
- All power supply and communication cables and circuit breaker must comply with applicable local and national codes.
- Exterior color code is approximate value.
- It is difficult to measure air flow rate of sleep because of small values.
- Maximum heating capacity is for heating operation without any frost.
- Fan motor speed could vary ± 20 rpm according to the operating conditions.
- It may cause reliability, performance, noise, and vibration problem, unless meeting the range of connecting pipe length. Keep the minimum piping length by making loops, although indoor unit and outdoor unit are close.
- This product contains fluorinated greenhouse gases.
- Some specifications may be changed without notifications due to our policy of innovation.
- Test conditions are based on EN 14511 and EN 14825.

4. Function List

Category	Function	Description	
Air Flow	Air Supply Outlet	The number of air outlet from the indoor unit	
	Airflow Direction Control (Left & Right)	Controlling a left-right direction of the indoor air flow	
	Airflow Direction Control (Up & Down)	Controlling a up-down direction of the indoor air flow	
	Auto Swing (Left & Right)	Auto swing air flow right and left for quick-cooling & Heating	
	Auto Swing (Up & Down)	Auto swing air flow up and down for quick-cooling & Heating	
	Fan Speed Steps (Fan / Cool / Heat)	Step adjustable wind strength at each mode	
	Natural Wind (Auto Wind)	Wind strength changes at regular intervals automatically	
	Jet Cool / Jet Heat (Power Wnd)	Wind strength is set to the maximum for 30 minutes	
	Comfort Air	Set the vane to a preset position in order to make an indirect wind	
	Soft Air	Stay comfortably cool with no chilly drafts	
Air Purifying	AI Air	Operate automatically by detecting the surrounding environment and user characteristics.	
	Prefilter (Washable)	Capture dust particles over 10µm in size(Basic Filter)	
	Fine Dust Filter(Micro Dust Filter)	Capture dust particles over 0.3µm in size(Optional Filter)	
	Ultra Fine Dust Filter(Ion Diffuser)	Capture dust particles over 1.0µm in size(Optional Filter+Ion Diffuser)	
Installation	Allergy Filter	Capture all allergy-causing substances such as house dust and mites floating in the air	
	Plasmaster Ionizer	Reduce harmful microscopic particles and odor	
Reliability	Drain Pump	Water drain pump for indoor unit	
	Hot Start	In the heating mode, the hot wind from the beginning	
	Self Diagnosis	Self-diagnostic for product protection	
	De-ice Control (Defrost)	In the heating mode, de-icing of the outdoor heat exchanger automatically	
Convenience	Dry (Dehumidification) Operation	Prevent the growth of mold by removing excess moisture from an area with high humidity	
	Auto Changeover	Change the operation mode(cooling & heating) automatically to maintain the set temperature	
	Auto Operation (Artificial Intelligence)	The fan and setting temperature adjust automatically, base on room temperature	
	Auto Cleaning (Coil Dry)	Prevent the formation of bacteria and mold on the heat exchanger	
	Auto Restart Operation	If power is resupplied after blackout, product restart automatically	
	Child Lock ¹	Only for wired-remote controller. Lock the buttons to prevent children control	
	Forced Operation	Use the forced switch of the indoor unit to operate the air conditioner when the remote control is unavailable	
	Group Control ¹	Only for wired-remote controller. Control multiple indoor units at the same time	
	Sleep Mode	Set the off timer and fan speed is decreasing to make quiet environment for comfort sleep	
	Timer 24hr (On/Off) / 7hr (Off)	Set the on/off timer	
	Timer (Weekly) ¹	Only for wired-remote controller. Set the on/off timer	
	Two Thermistor Control ¹	If there is a temperature difference between room temperature and desired temperature, you can use this function in other to prevent insufficient cooling and insufficient heating	
	Low Ambient Operation	The cooling operation is possible even in conditions of extreme cold	
	Overheating Protection	If there is a temperature difference between room temperature and desired temperature, you can use this function in other to prevent over-heating	
	Low Heating	Using less energy helps keep the room warm when going out	
	Voice Control	Customer can control the aircon by voice without wireless remote controller	
	Outdoor Silent Mode	The overall sound level of the outdoor unit drops by up to 3dB	
	Mosquito Away	An ultrasonic sound that mosquitoes detest is emitted to drives away mosquitoes	
	Energy Saving	Indoor Unit Display Type	-
		Indoor Unit Display Light	Set the brightness of the display on the indoor unit
Energy Display		Show the power consumption	
Air Quality Indicator (Dust Sensor)		Sense microscopic dusts in the room and let the air purifying system work without additional maneuver	
Energy Saving		Control the optimal desired temperature to save energy	
Energy Control		The customer can control the power consumption or current directly to save energy	
Gen Mode		In areas where electricity is limited, customer can continue to use household appliances with the air-conditioner by reducing power consumption	
Individual Control		Wired Remote Controller ²	-
		Handheld Wireless Controller	-
CAC Network Function		General Central Controller (Non LGAP)	-
	Network Solution (LGAP)	-	
	Dry Contact ²	-	
	PDI (Power Distribution Indicator) ²	-	
Special Function Kit	Outdoor Unit PI 485 ²	-	
	Wi-Fi ²	Easily access and control an air conditioner's functions from anywhere	
	Water Level Sensor Connection ²	Detect the water level in drain pan	
	Wind Baffle Kit ²	With wind baffle installed, the minimum temperature will be -18 °C (0 °F)D.B. in cooling	
	Sump Heater	Prevent the accumulation of freezing on the outdoor-heat-exchanger during winter (Flexible Type)	
	Sheath Heater ²	Prevent the accumulation of freezing on the outdoor-heat-exchanger during winter (Hard Type)	
	Crank Case Heater	Pre-heating the compressor during winter	
Others	Smart Inverter Monitoring System (SIMs) ²	Help you to easily monitor, diagnose the air conditioner and get a quick resolution	
	Mode Lock	Set up the unit available to use only cooling or heating mode in the heat pump model	
	DRED (Demand Response Enabling Device)	-	

Note

- These functions must be applied according to the model. Please refer to the following function list for each model.
- ¹ : This function can be operated only when the wired remote controller is connected. The applicability of each function depends on the above table.
- ² : Optional accessories must be purchased separately. If shown as "Embedded", this function is included in product.
- The function Wi-Fi is only compatible with 2.4 GHz band. (802.11 b/g/n)
- Some specifications may be changed without notifications due to our policy of innovation.

4. Function List

Category	Function	P12SND.SS0
		S3-M120A1H0.EC6GEEU
Air Flow	Air Supply Outlet	2
	Airflow Direction Control (Left & Right)	5 Steps
	Airflow Direction Control (Up & Down)	6 Steps
	Auto Swing (Left & Right)	0
	Auto Swing (Up & Down)	0
	Fan Speed Steps (Fan / Cool / Heat)	6 / 6 / 6
	Natural Wind (Auto Wind)	0
	Jet Cool / Jet Heat (Power Wind)	0 / 0
	Comfort Air	X
	Soft Air	0
	Vane Type	Dual Vane
	AI Air	0
Air Purifying	Prefilter (Washable)	0
	Fine Dust Filter(Micro Dust Filter)	X
	Ultra Fine Dust Filter / PM 1.0 Sensor	X
	Allergy Filter	0
	Plasmaster Ionizer	X
Installation	Drain Pump	X
	Hot Start	0
Reliability	Self Diagnosis	0
	De-ice Control (Defrost)	0
	Dry (Dehumidification) Operation	0
	Auto Changeover	0
Convenience	Auto Operation (Artificial Intelligence)	X
	Auto Cleaning (Coil Dry)	0
	Auto Restart Operation	0
	Child Lock ¹	0
	Forced Operation	0
	Group Control ¹	X
	Sleep Mode	12hr
	Timer 24hr (On/Off) / 7hr (Off)	0 / X
	Timer (Weekly) ¹	0
	Two Thermistor Control ¹	0
	Low Ambient Operation	0
	Overheating Protection	0
	Low Heating	0
	Voice Control	X
	Outdoor Silent Mode	0
	Mosquito Away	X
	Smart Diagnosis	0
	Indoor Unit Display Type	Number Display
	Indoor Unit Display Light	On/Off
	Energy Display	0 (ThinQ only)
Air Quality Indicator (Dust Sensor)	X	
Energy Saving	Energy Saving	X
	Energy Control	Active Energy Control
	Gen Mode	X
Individual Control	Wired Remote Controller (Premium) ²	X
	Wired Remote Controller (Standard) ²	PQRCVSL0(QW) / PREMTB(0/B)01
	Wired Remote Controller (Simple with Mode Selection) ²	PQRCVCL0Q(W)
	Wired Remote Controller (Simple without Mode Selection) ²	PQRCHCA0Q(W)
	Handheld Wireless Controller (See Remote Controller Section)	AKB76044811
CAC Network Function	Setting Temperature Range (Cooling)	18~30 °C (64~86 °F)
	Setting Temperature Range (Heating)	16~30 °C (60~86 °F)
	General Central Controller (Non LGAP)	X
	Network Solution (LGAP)	0
	Dry Contact ²	PDRYCB000, PDRYCB100, PDRYCB400, PDRYCB500
Special Function Kit	PDI (Power Distribution Indicator) ²	X
	Outdoor Unit PI 485 ²	X
	Wi-Fi ²	Embedded
	Water Level Sensor Connection ²	X
	Wind Baffle Kit ²	X
Others	Sump Heater	X
	Sheath Heater ²	X
	Crank Case Heater	X
Others	Mode Lock	Cooling Only or Heating Only
	DRED (Demand Response Enabling Device)	X

Note

- 0 : Applied, X : Not applied
- Filters are optional in some specific areas.
- ¹ : This function can be operated only when the wired remote controller is connected. The applicability of each function depends on the above table.
- ² : Optional accessories must be purchased separately. If shown as "Embedded", this function is included in product.
- The function Wi-Fi is only compatible with 2.4 GHz band. (802.11 b/g/n)
- Some specifications may be changed without notifications due to our policy of innovation.

5. Dimensional Drawings

5.1 Indoor Unit

P12SND.NS0 (S3NM120A1H0.EC6GEEU)

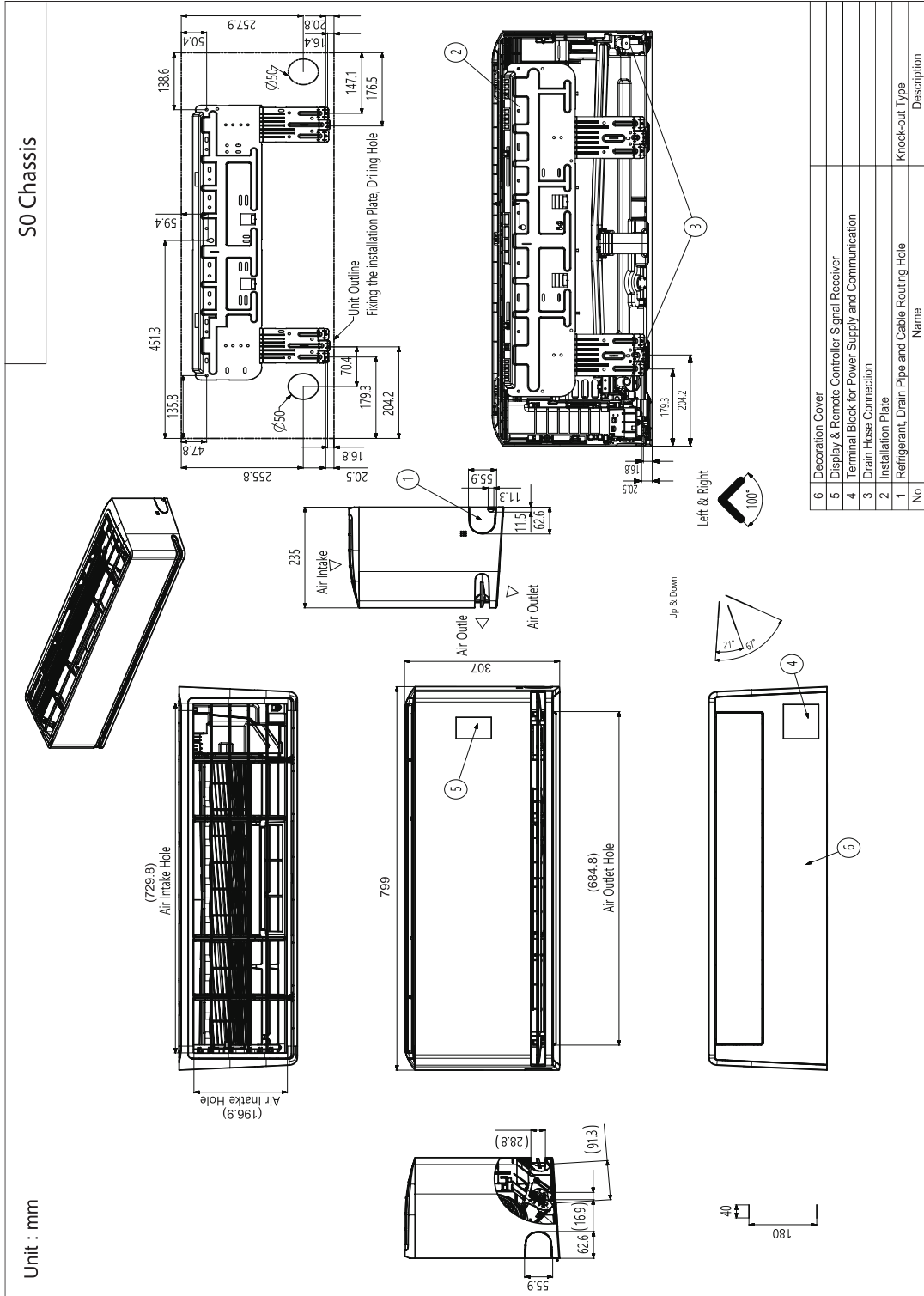

5. Dimensional Drawings

5.2 Outdoor Unit

P12SND.U12A (S3UM120A1H0.EC6GEEU)

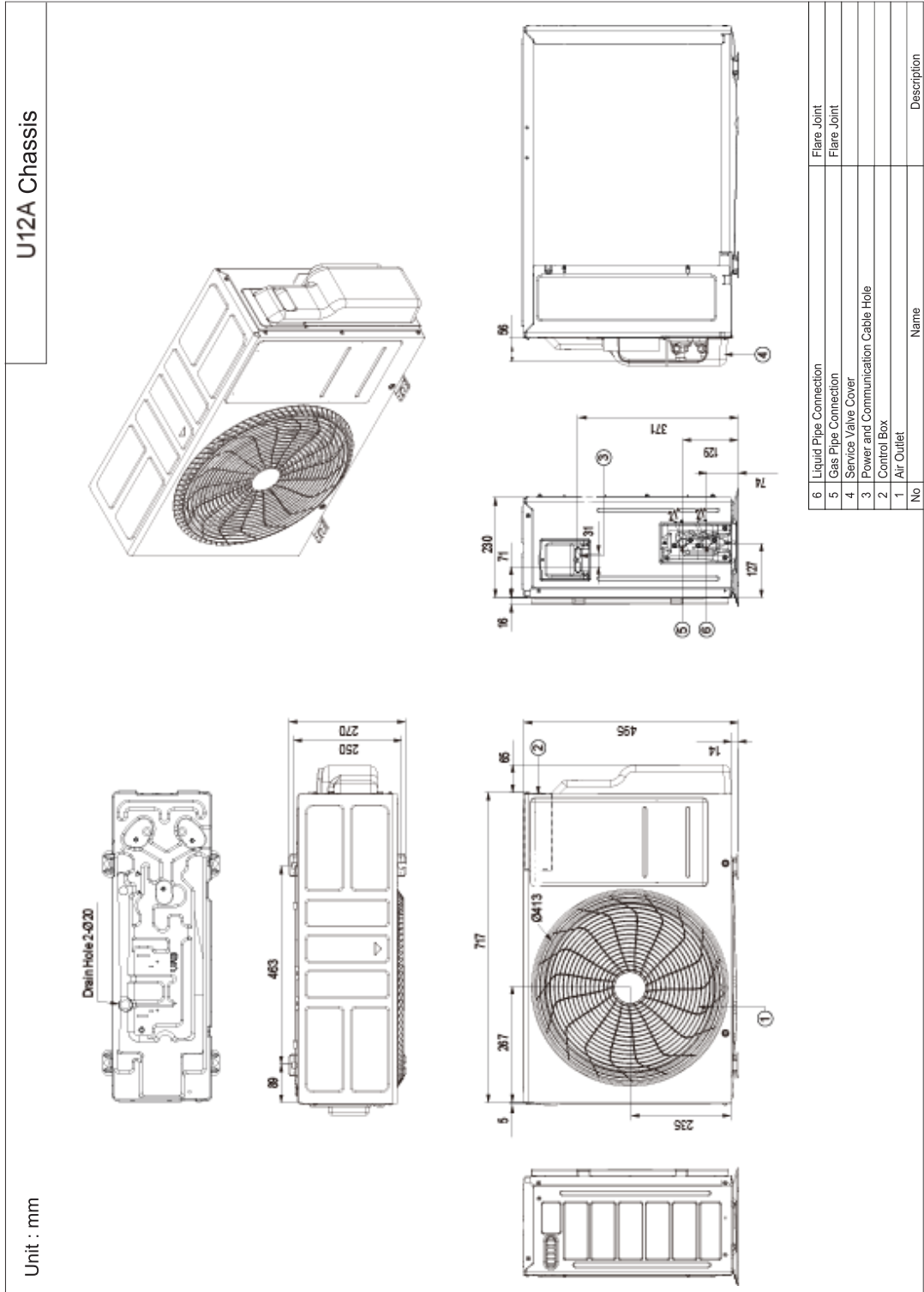

5. Dimensional Drawings

5.3 Corner Weight and Center of Gravity Dimension for Outdoor Unit

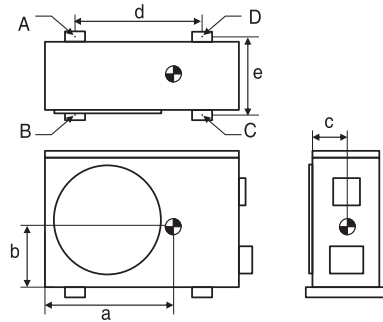

Model	Tool	Weight (kg)		Center of Gravity (mm)			Leg (mm)		Corner Weight (kg)			
		Shipping	Net	a	b	c	d	e	A	B	C	D
P12SND.U12A	U12A	26.5	25.0	475	219	113	463	256	1.8	2.3	10.7	10.2

Model	Tool	Weight (lb.)		Center of Gravity (in.)			Leg (in.)		Corner Weight (lb.)			
		Shipping	Net	a	b	c	d	e	A	B	C	D
P12SND.U12A	U12A	58.4	55.1	18-11/16	8-5/8	4-7/16	18-7/32	10-3/32	4.0	5.1	23.5	22.4

Note

- Design features and information of indoor and outdoor unit may be changed without notifications due to our policy of innovation.
- The center of gravity and corner weight may be different from the actual values because these are simulation results.

6. Wiring Diagrams

6.1 Indoor Unit

P12SND.NS0 (S3NM120A1H0.EC6GEEU)

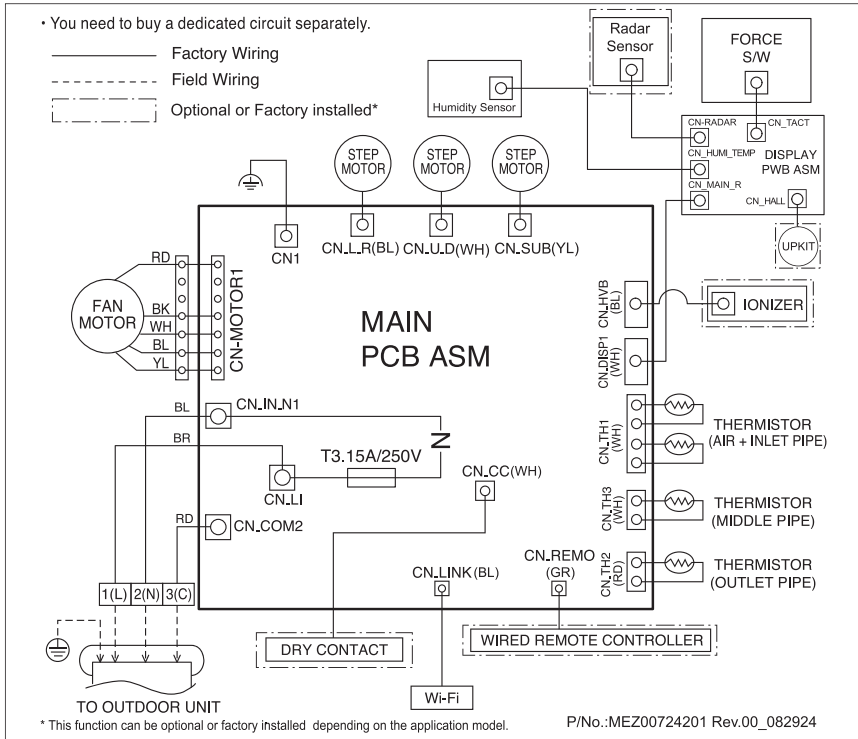

6. Wiring Diagrams

6.2 Outdoor Unit

P12SND.U12A (S3UM120A1H0.EC6GEEU)

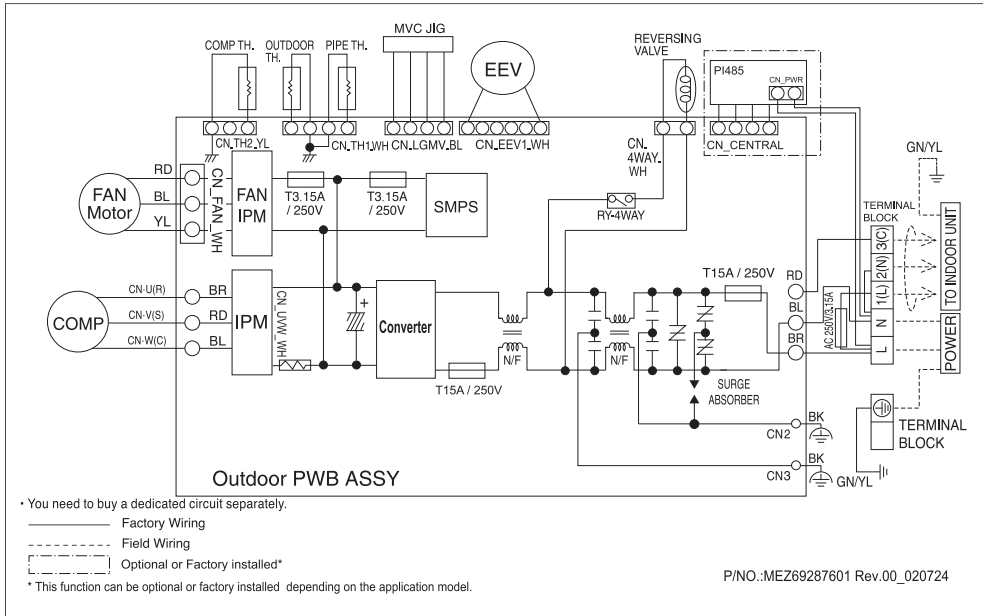

7. Refrigerant Cycle Diagrams

P12SND.SS0 (S3-M120A1H0.EC6GEEU)

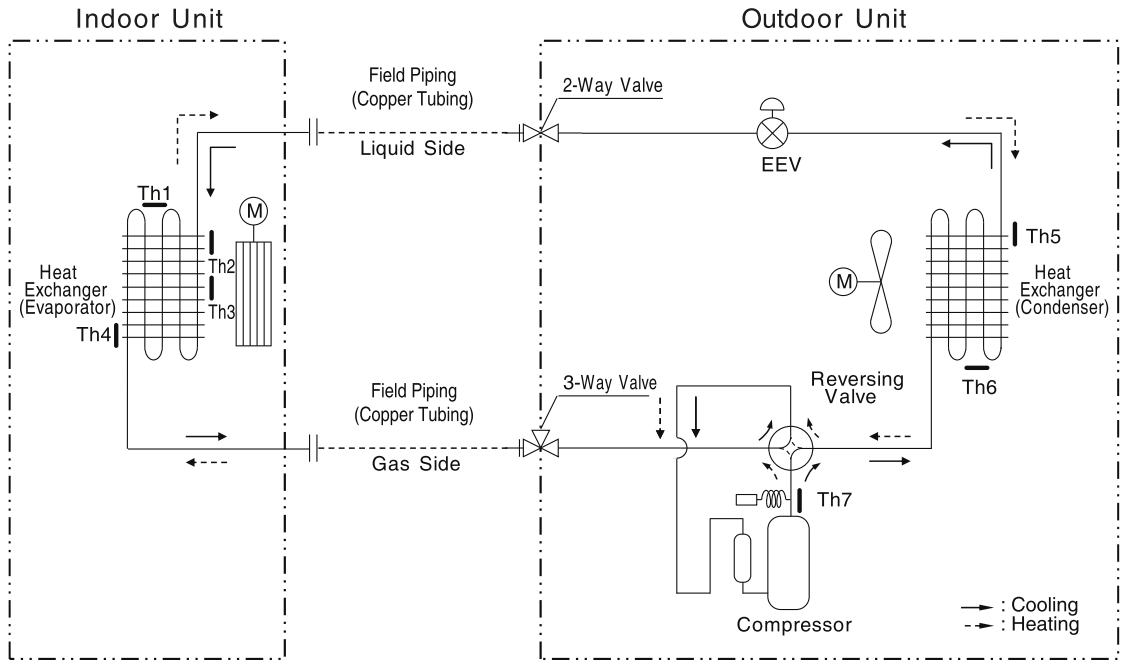

Loc.	Description	PCB Connector
Th1	Thermistor for indoor air temperature	CN-TH1 (Indoor)
Th2	Thermistor for evaporator inlet temperature	CN-TH1 (Indoor)
Th3	Thermistor for evaporator middle temperature	CN-TH3 (Indoor)
Th4	Thermistor for evaporator outlet temperature	CN-TH2 (Indoor)
Th5	Thermistor for outdoor air temperature	CN-TH1 (Outdoor)
Th6	Thermistor for condenser temperature	CN-TH1 (Outdoor)
Th7	Thermistor for discharge pipe temperature	CN-TH2 (Outdoor)

◆ Refrigerant Pipe Connection Port Diameters

Model	Gas		Liquid		Capillary Tube
	mm	inch	mm	inch	
P12SND.SS0	ø 9.52	ø 3/8	ø 6.35	ø 1/4	-

Appendix	Heat Exchanger	Propeller Fan	Cross Flow Fan	Compressor	Accumulator	Reversing Valve (4 Way Valve)
	EEV (Electronic Expansion Valve)	Capillary Tube	2-Way Valve 3-Way Valve	Temperature Sensor	Pressure Sensor	Pressure Switch
	Check Valve	Flare Joint	Muffler	Strainer		

8. Capacity Tables

8.1 Rated Cooling Capacity

P12SND.SS0 (S3-M120A1H0.EC6GEEU)

Outdoor Air Temperature	Indoor Air Temperature : °C DB / °C WB																				
	18 / 12			20 / 14			22 / 16			25 / 18			27 / 19			29 / 19			32 / 23		
°C DB	TC	SHC	PI	TC	SHC	PI	TC	SHC	PI	TC	SHC	PI	TC	SHC	PI	TC	SHC	PI	TC	SHC	PI
-15	2.56	2.09	0.49	3.20	2.23	0.58	3.84	2.36	0.67	4.64	2.53	0.79	5.12	2.63	0.85	5.37	3.39	0.89	5.71	4.44	0.93
-10	2.64	2.18	0.52	3.30	2.32	0.61	3.96	2.46	0.71	4.78	2.64	0.82	5.28	2.74	0.89	5.53	3.53	0.93	5.89	4.63	0.98
-5	2.83	2.34	0.51	3.40	2.49	0.62	3.98	2.64	0.72	4.70	2.83	0.86	5.13	2.94	0.94	5.41	3.61	0.98	5.80	4.53	1.04
-1	2.99	2.47	0.56	3.52	2.60	0.66	4.05	2.74	0.75	4.71	2.91	0.87	5.11	3.01	0.95	5.39	3.62	0.99	5.78	4.47	1.05
0	3.03	2.51	0.58	3.55	2.64	0.67	4.07	2.77	0.76	4.72	2.93	0.88	5.11	3.03	0.95	5.39	3.63	0.99	5.77	4.45	1.05
4	3.21	2.65	0.64	3.68	2.77	0.72	4.15	2.88	0.80	4.73	3.02	0.90	5.09	3.11	0.96	5.36	3.64	1.00	5.75	4.39	1.06
10	3.43	2.84	0.72	3.84	2.93	0.78	4.25	3.02	0.85	4.76	3.13	0.93	5.06	3.20	0.98	5.34	3.66	1.02	5.72	4.30	1.08
16	3.65	3.02	0.79	4.00	3.09	0.84	4.34	3.16	0.89	4.78	3.24	0.95	5.04	3.30	0.99	5.31	3.69	1.03	5.69	4.22	1.09
18	3.62	2.99	0.83	3.95	3.08	0.88	4.28	3.16	0.93	4.69	3.27	0.99	4.93	3.33	1.02	5.21	3.70	1.07	5.59	4.20	1.12
20	3.60	2.98	0.86	3.92	3.07	0.90	4.23	3.16	0.95	4.63	3.28	1.01	4.87	3.35	1.04	5.14	3.70	1.08	5.52	4.19	1.14
25	3.34	2.80	0.85	3.60	2.92	0.89	3.87	3.03	0.93	4.21	3.18	0.98	4.41	3.26	1.01	4.67	3.57	1.04	5.03	3.99	1.09
30	3.06	2.64	0.84	3.29	2.77	0.87	3.51	2.91	0.90	3.79	3.07	0.95	3.96	3.17	0.97	4.20	3.43	1.00	4.53	3.79	1.05
35	2.78	2.48	0.83	2.96	2.63	0.85	3.14	2.78	0.88	3.36	2.97	0.91	3.50	3.09	0.93	3.72	3.30	0.96	4.03	3.60	1.00
41	2.60	2.22	0.97	2.78	2.38	1.00	2.97	2.54	1.03	3.20	2.73	1.07	3.34	2.85	1.09	3.55	3.03	1.12	3.83	3.28	1.17
46	2.31	1.89	1.07	2.48	2.04	1.10	2.66	2.18	1.14	2.87	2.36	1.18	3.01	2.47	1.21	3.19	2.61	1.24	3.44	2.82	1.29
48	2.25	1.84	1.08	2.42	1.98	1.11	2.59	2.13	1.15	2.80	2.30	1.19	2.93	2.41	1.22	3.11	2.55	1.25	3.36	2.75	1.31

Symbol

DB : Dry Bulb Temperature
 WB : Wet Bulb Temperature
 TC : Total Capacity
 SHC : Sensible Heating Capacity
 PI : Power Input
 (Comp.+ Indoor Fan Motor + Outdoor Fan Motor)

[°C]
 [°C]
 [kW]
 [kW]

Note

1. All capacities are net, evaporator fan motor heat is deducted.
2. Direct interpolation is permissible. Do not extrapolate.
3. Capacities are based on the following conditions.
 - Interconnecting Piping Length 5 m (16.4 ft.)
 - Level Difference of Zero.

8. Capacity Tables

8.2 Rated Heating Capacity

P12SND.SS0 (S3-M120A1H0.EC6GEEU)

Outdoor Air Temperature		Indoor Air Temperature : °C DB													
		16		18		20		21		22		24		30	
°C DB	°C WB	TC	PI	TC	PI	TC	PI	TC	PI	TC	PI	TC	PI	TC	PI
-14	-15	3.39	1.40	3.28	1.39	3.25	1.39	3.22	1.38	3.19	1.38	3.13	1.36	3.06	1.36
-9	-10	3.65	1.47	3.54	1.45	3.50	1.45	3.47	1.44	3.44	1.44	3.37	1.42	3.29	1.42
-4	-5	3.76	1.45	3.64	1.43	3.61	1.43	3.57	1.42	3.54	1.42	3.47	1.41	3.39	1.41
1	0	3.77	1.31	3.65	1.30	3.62	1.30	3.58	1.28	3.55	1.28	3.48	1.27	3.40	1.27
2	1	3.77	1.28	3.66	1.27	3.62	1.27	3.58	1.26	3.56	1.26	3.49	1.24	3.40	1.24
7	6	3.85	0.91	3.74	0.90	3.70	0.90	3.66	0.89	3.64	0.89	3.56	0.88	3.48	0.88
12	11	5.57	1.61	5.41	1.59	5.35	1.59	5.30	1.57	5.26	1.57	5.15	1.56	5.03	1.56
18	14	5.81	1.65	5.63	1.64	5.58	1.64	5.52	1.62	5.48	1.62	5.37	1.60	5.24	1.60
24	18	6.00	1.70	5.82	1.68	5.76	1.68	5.70	1.67	5.66	1.67	5.55	1.65	5.42	1.65

Symbol

DB : Dry Bulb Temperature

WB : Wet Bulb Temperature

TC : Total Capacity

PI : Power Input

(Comp.+ Indoor Fan Motor + Outdoor Fan Motor)

[°C]

[°C]

[kW]

[kW]

Note

1. All capacities are net, evaporator fan motor heat is deducted.
2. Direct interpolation is permissible. Do not extrapolate.
3. Capacities are based on the following conditions.
 - Interconnecting Piping Length 5 m (16.4 ft.)
 - Level Difference of Zero.

9. Capacity Coefficient Factor

9.1 Capacity Change Rate (%)

Model	Refrigerant Pipe Length											
	m	5	7.5	10	15	20	25	30	35	40	45	50
	ft	16.4	24.6	32.8	49.2	65.6	82.0	98.4	114.8	131.2	147.6	164.0
P12SND.SS0 (S3-M120A1H0.EC6GEEU)	Cooling	100	100	-	-	-	-	-	-	-	-	-
	Heating	100	100	-	-	-	-	-	-	-	-	-

9. Capacity Coefficient Factor

9.2 Pipe Size, Length and Elevation

Model	Pipe Size				Standard Pipe Length [m (ft.)]	Min. / Max. Pipe Length A [m (ft.)]	Max. Elevation B [m (ft.)]	Additional Refrigerant [g/m (oz./ft.)]	No Charge Pipe Length [m (ft.)]
	Gas		Liquid						
	mm	inch	mm	inch					
P12SND.SS0 (S3-M120A1H0.EC6GEEU)	ø 9.52	ø 3/8	ø 6.35	ø 1/4	7.5 (24.6)	3 / 20 (9.8 / 65.6)	10 (32.8)	20 (0.22)	7.5 (24.6)

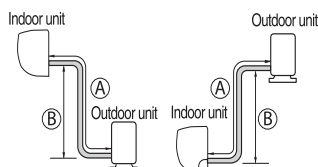

⚠ WARNING

- It may cause reliability, performance, noise, and vibration problem, if piping limitations are not met. Keep minimum piping length by making loops, although indoor unit and outdoor unit are close.

9. Capacity Coefficient Factor

9.3 Additional Refrigerant Charge

Model	Refrigerant Pipe Length												
	m	5	7.5	10	12.5	15	20	25	30	35	40	45	50
	ft	16.4	24.6	32.8	41.0	49.2	65.6	82.0	98.4	114.8	131.2	147.6	164.0
P12SND.SS0 (S3-M120A1H0.EC6GEEU)	Additional Charge [g (oz.)]	0	0	50 (1.8)	100 (3.6)	150 (5.4)	250 (9.0)	-	-	-	-	-	-

Note

- Capacity is based on standard length and maximum allowance length is on the basis of reliability.
- Equivalent Pipe Length = Actual Pipe Length + Number of Bends x 0.3
- Calculation : X g (oz.) = [(Refrigerant Pipe Length) - (No Charge Pipe Length)] × (Additional Refrigerant)
- There is no need to charge refrigerant till no charge pipe length based on reliability

10. Operation Range

P12SND.SS0 (S3-M120A1H0.EC6GEEU)

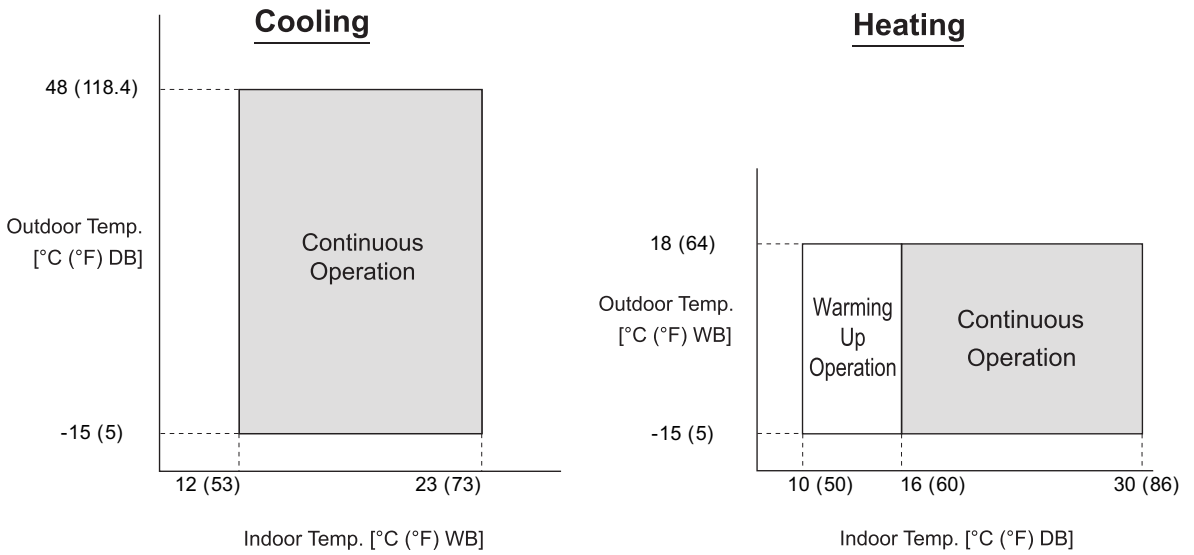

Note

The figures are based on the following conditions :
– Equivalent Piping Length : 7.5 m (24.6 ft.)
– Level Difference : 0 m (0 ft.)

11. Air Flow and Temperature Distributions (Reference Data)

P12SND.SS0 (S3-M120A1H0.EC6GEEU)

Cooling

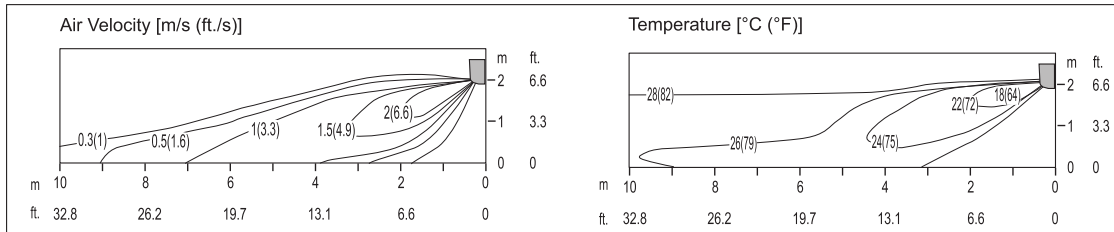

Side View

Discharge Angle : 45° (From the floor ▾)

Vertical Louver : Center

Fan Speed : Power

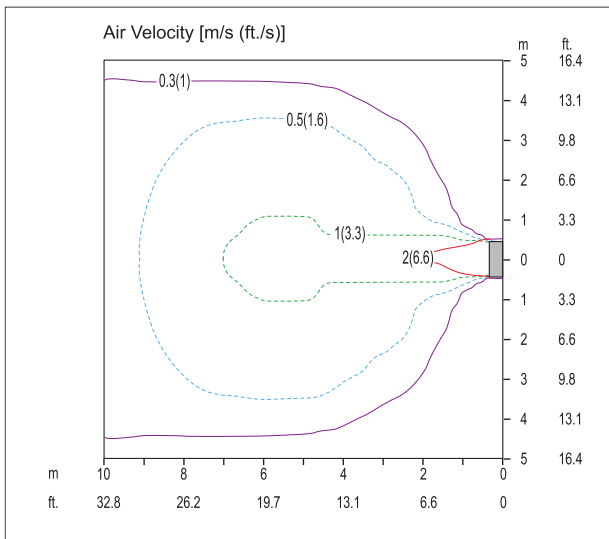

Top View

Discharge Angle : 45° (From the floor ▾)

Vertical Louver : Center

Fan Speed : Power

Air Speed 0.3 m/s (1 ft./s) Range : 12 m (39.4 ft.)

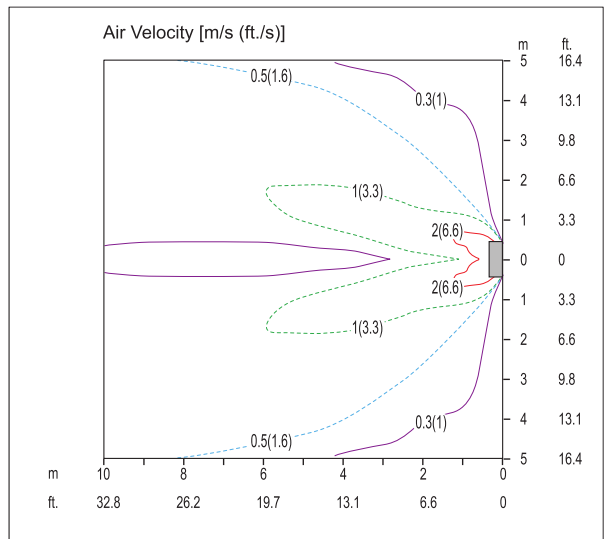

Top View

Discharge Angle : 45° (From the floor ▾)

Vertical Louver : Left & Right

Fan Speed : Power

11. Air Flow and Temperature Distributions (Reference Data)

Heating

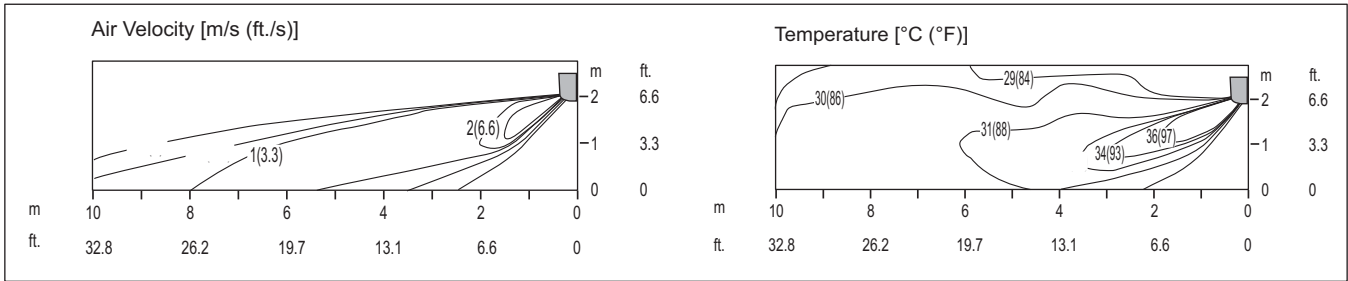

Side View

Discharge Angle : 55° (From the floor ▾)

Vertical Louver : Center

Fan Speed : Power

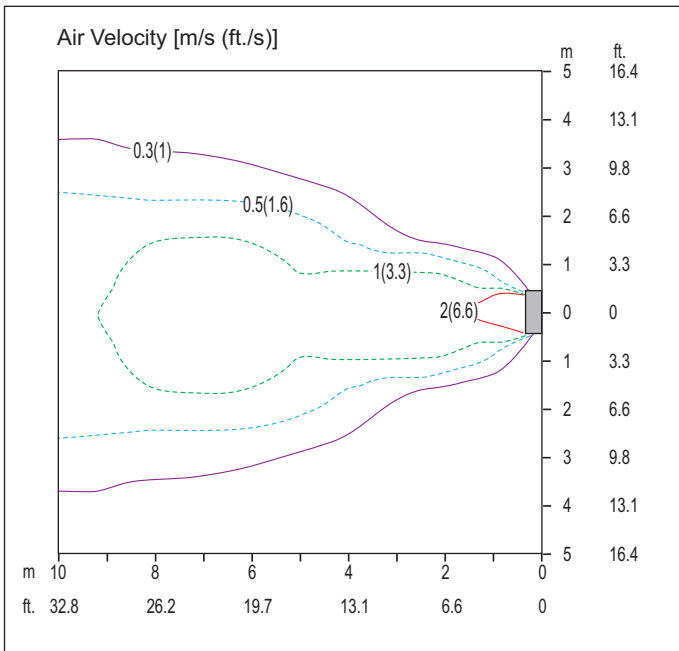

Top View

Discharge Angle : 55° (From the floor ▾)

Vertical Louver : Center

Fan Speed : Power

Air Speed 0.3 m/s (1 ft./s) Range : 12.5 m (41 ft.)

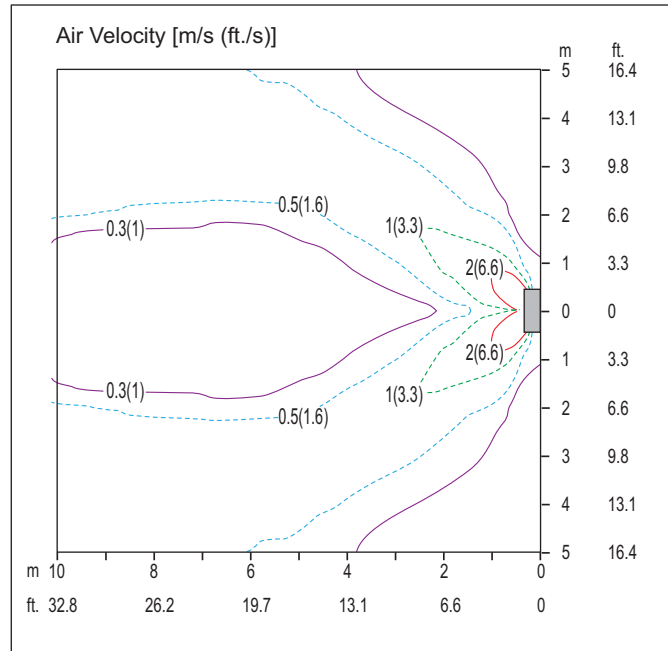

Top View

Discharge Angle : 55° (From the floor ▾)

Vertical Louver : Left & Right

Fan Speed : Power

12. Sound Levels (Reference Data)

12.1 Sound Pressure Level (Indoor Unit)

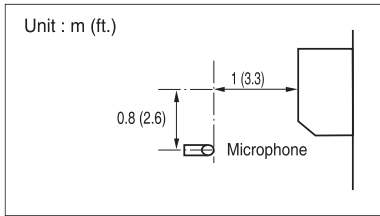

Note

- Sound measured at 1 m (3.3 ft.) away from the unit.
- Data is valid at free field condition.
- Data is valid at nominal operation condition.
- Reference acoustic pressure 0 dB=20 µPa.
- Sound level will vary depending on a range of factors such as the construction(acoustic absorption coefficient) of particular room in which the equipment is installed.
- The operating conditions are assumed to be standard.
- Sound pressure level is measured on the rated condition in the anechoic rooms by ISO 3745 standard.
- Sound level is measured in an anechoic room and may be different according to the test condition or equipment.

Model	Sound Levels [dB (A)]					
	Cooling			Heating		
	H	M	L	H	M	L
P12SND.NS0 (S3NM120A1H0.EC6GEEU)	42	35	27	42	35	27

12. Sound Levels (Reference Data)

P12SND.NS0 (S3NM120A1H0.EC6GEEU)

Cooling

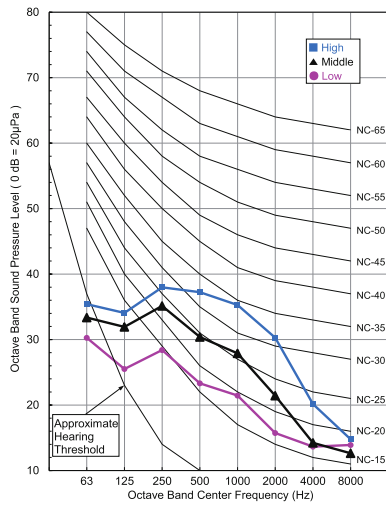

Heating

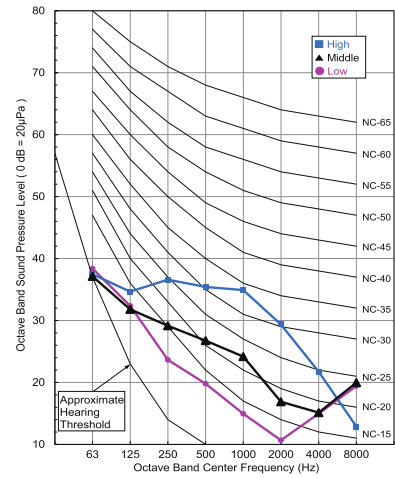

12. Sound Levels (Reference Data)

12.2 Sound Pressure Level (Outdoor Unit)

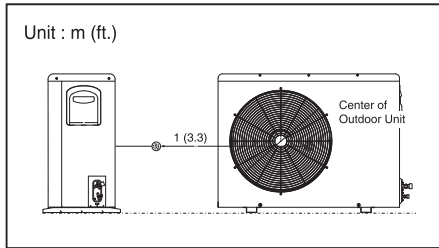

Note

- Sound measured at 1 m (3.3 ft.) away from the unit.
- Data is valid at free field condition.
- Data is valid at nominal operation condition.
- Reference acoustic pressure 0 dB=20 μPa.
- Sound level will vary depending on a range of factors such as the construction(acoustic absorption coefficient) of particular room in which the equipment is installed.
- The operating conditions are assumed to be standard.
- Sound pressure level is measured on the rated condition in the anechoic rooms by ISO 3745 standard.
- Sound level is measured in an anechoic room and may be different according to the test condition or equipment.

Model	Sound Levels [dB (A)]	
	Cooling	Heating
	H	H
P12SND.U12A (S3UM120A1H0.EC6GEEU)	49	51

12. Sound Levels (Reference Data)

P12SND.U12A (S3UM120A1H0.EC6GEEU)

Cooling

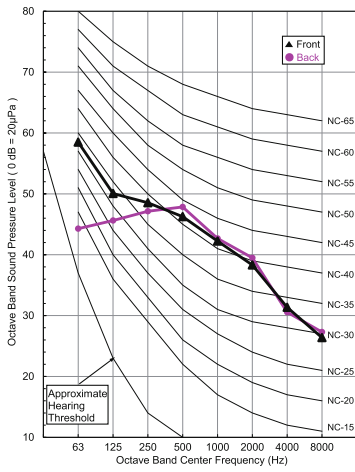

Heating

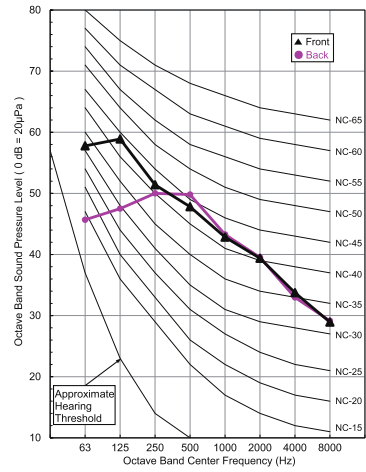

12. Sound Levels (Reference Data)

12.3 Sound Power Level (Indoor Unit)

Note

- Data is valid at diffuse field condition.
- Data is valid at nominal operating condition.
- Sound level can be increased in static pressure mode or used air guide.
- Sound power level is measured on the rated condition in the reverberation rooms.
- Sound level will vary depending on a range of factors such as the construction (acoustic absorption coefficient) of particular room in which the equipment is installed.
- Reference acoustic intensity $0\text{dB} = 10\text{E-}6\mu\text{W}/\text{m}^2$
- Sound power level is measured on the rated condition in the reverberation rooms by ISO 3741 standard.

Model	Sound Levels [dB (A)]
P12SND.NS0 (S3NM120A1H0.EC6GEEU)	60

12. Sound Levels (Reference Data)

P12SND.NS0 (S3NM120A1D0.EC6GEEU)

Cooling

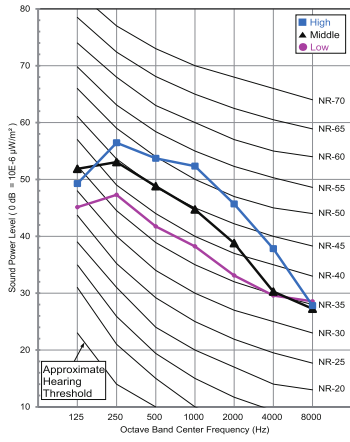

Heating

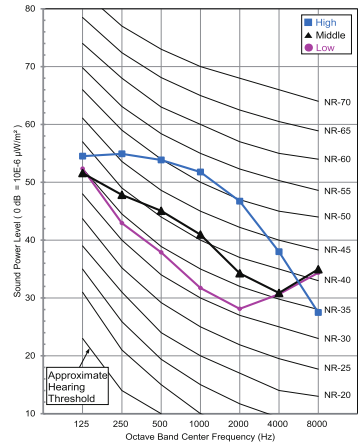

12. Sound Levels (Reference Data)

12.4 Sound Power Level (Outdoor Unit)

Note

- Data is valid at diffuse field condition.
- Data is valid at nominal operating condition.
- Sound level can be increased in static pressure mode or used air guide.
- Sound power level is measured on the rated condition in the reverberation rooms.
- Sound level will vary depending on a range of factors such as the construction (acoustic absorption coefficient) of particular room in which the equipment is installed.
- Reference acoustic intensity $0\text{dB} = 10\text{E-}6\mu\text{W}/\text{m}^2$
- Sound power level is measured on the rated condition in the reverberation rooms by ISO 3741 standard.

Model	Sound Levels [dB (A)]
P12SND.U12A (S3UM120A1H0.EC6GEEU)	60

12. Sound Levels (Reference Data)

P12SND.U12A (S3UM120A1H0.EC6GEEU)

Cooling

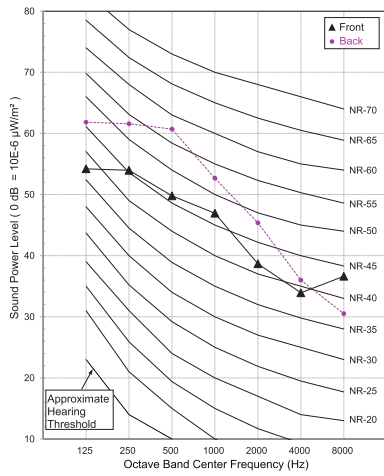

Heating

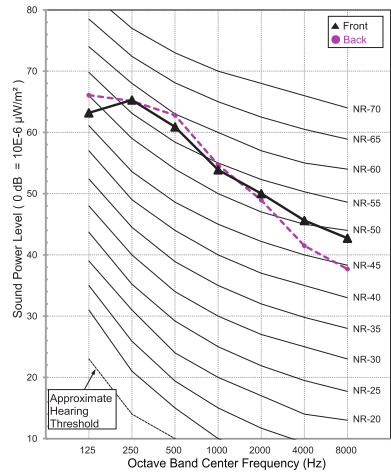

13. Remote Controller

Wireless Remote Controller

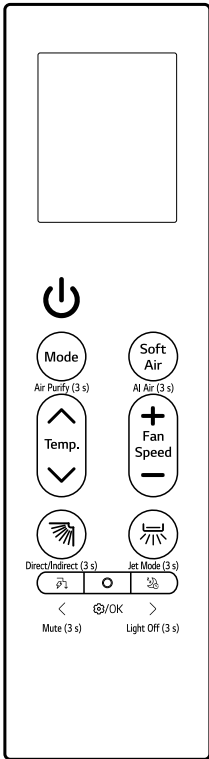

Image	Description
	Power Turns the appliance on or off.
	Connecting to LG ThinQ Press and hold the Power button for about 3 seconds to prepare the statue for connecting appliance and Wi-Fi.
	Mode Selects the desired operation mode. • Each press changes the modes in this order: Cooling → Auto → Dehumidification → Heating → Fan
	Air Purify (3 s) Press and hold the Mode button for about 3 seconds to supply clean, fresh air using ion particles and the filter.
	Soft Air Keep you cool without feeling a draft. • Each press changes the fan speeds in this order: Low → Medium → High
	AI Air (3 s) Press and hold the Soft Air button for about 3 seconds to operate automatically by detecting the surrounding environment and user characteristics.
	Temp. \wedge, \vee Adjusts the desired room temperature.
	Fan Speed $+$, $-$ Adjust the fan speed.
	(Up-Down Swing) Adjusts the airflow direction up and down.
	Direct/Indirect (3 s) Press and hold the button for about 3 seconds to set either a direct or Indirect airflow based on your preferences.
	Cleaning Mode While the remote control and appliance are turned off, press and hold the button for about 5 seconds to fix the vane for cleaning the vane easily.
	(Left-Right Swing) Adjusts the airflow direction left and right.
	Jet Mode (3 s) Press and hold the button for about 3 seconds to change the room temperature quickly.
	(Energy Control) Decrease the power input. You can control energy consumption.
	Mute (3 s) Press and hold the button for about 3 seconds to turn off the beep sound.
	Function Selects the desired function.
	(Sleep) Automatically turns the appliance off at a desired time. Use it before sleeping.
	Light Off (3 s) Press and hold the button for about 3 seconds to set the light off function.

P/No	Applied Model
AKB76044811	P12SND.NS0 (S3NM120A1H0.EC6GEEU)

14. Installation

14.1 Important Safety Instructions

The following safety guidelines are intended to prevent unforeseen risks or damage from unsafe or incorrect operation of the appliance. The guidelines are separated into 'WARNING' and 'CAUTION' as described below.



This symbol indicates that this appliance uses a flammable refrigerant. If the refrigerant is leaked and exposure to an external ignition source, there is a risk of fire.



This symbol is displayed to indicate matters and operations that can cause risk. Read the part with this symbol carefully and follow the instructions in order to avoid risk.



WARNING

This indicates that the failure to follow the instructions can cause serious injury or death.



CAUTION

This indicates that the failure to follow the instructions can cause the minor injury or damage to the product.



WARNING

To reduce the risk of explosion, fire, death, electric shock, injury or scalding to persons when using this product, follow basic precautions, including the following :

- The information contained in the manual is intended for use by a qualified service technician who is familiar with the safety procedures and equipped with the proper tools and test instruments.
- The appliance shall be installed in accordance with local and national wiring regulations.
- Means for disconnection must be incorporated in the fixed wiring in accordance with the wiring rules.
- If the supply cord is damaged, it must be replaced by the manufacturer or its service agents or similarly qualified person in order to avoid a hazard.
- Appliance shall be disconnected from its power source during service and when replacing parts.
- Failure to read and follow all instructions in this manual can result in equipment malfunction, property damage, personal injury and/or death.
- Check that the appliance's voltage level is 90 % or higher than the rated voltage. To check it, refer to the label attached to the side of the appliance.
- Do not install the appliance on an unstable surface or in a place where there is danger of it falling.
- This appliance must be grounded. In the event of malfunction or breakdown, grounding will reduce the risk of electric shock by providing a path of least resistance for electric current.
- Improper connection of the equipment-grounding conductor can result in risk of electric shock. Check with a qualified electrician or service personnel if you are in doubt as to whether the appliance is properly grounded.
- If the power supply cable is damaged or the cable connection is loose, do not use the power supply cable and contact an authorized service center.
- Do not connect the ground wire to a gas pipe, a lightning rod, or a telephone ground wire.

14. Installation

- Do not share the power supply for this unit with other with other products or devices, it must be a dedicated power source for this this appliance.
- Do not modify or extend the power cable.
- Ensure the power cable is secure so that it does not come out while the appliance is operating.
- Do not touch the power cable or the appliance controls with wet hands.
- Cut the power during a severe thunderstorm or lightening or when not in use for a long period of time.
- Do not grab the power cable when removing the plug, but rather hold the power plug tightly.
- Do not bend the power cable excessively or place a heavy object on it.
- Do not turn on the circuit breaker or power when covers are removed or opened.
- Make sure that the pipe and the power cable connecting the indoor and outdoor units are not pulled too tight when installing the appliance.
- Install dedicated electric outlet and circuit breaker for the appliance.
- Make sure to close the cover of the control box after connecting the wiring to the appliance.
- Loose connections may cause electrical sparks, injury, and death.
- Do not install the appliance in a place where flammable liquids or gases such as gasoline, propane, paint thinner, etc., are stored.
- Only use the refrigerant designated on the label, do not put any foreign substances into the appliance.
- Use non-flammable gas (nitrogen) to check for leak and to purge air.
- Inert gas (oxygen free nitrogen) should be used when you checking for leaks, cleaning or repairs of pipes etc. If you are using combustible gases including oxygen, appliance may have the risk of fires and explosions.
- Do not use copper pipes which are deformed. Otherwise, the expansion valve or capillary tube may become blocked with contaminants.
- When installing or relocating the appliance, consult with a qualified technician to set up the appliance. The appliance should not be installed by someone without proper qualifications.
- Operating the appliance while it is disconnected to the pipe could result in explosion and damage. Use the appliance after connecting it to the pipe once the appliance has been relocated and the refrigerant circuit repaired.
- Do not place a heater or other heating appliances near the power cable.
- Keep any required ventilation openings clear of obstruction.
- Use only refrigerant grade pipe specific for R32 refrigerant. Do not use R22 products, which have lower pressure ratings and can result in excessive pressure, explosion and injury.
- Compliance with national gas regulations shall be observed.
- Servicing shall only be performed as recommended by the equipment manufacturer. Maintenance and repair requiring the assistance of other skilled personnel shall be carried out under the supervision of the person competent in the use of flammable refrigerants.
- The installation of pipe-work shall be kept to a minimum.
- Any person who is involved with working on or breaking into a refrigerant circuit should hold a current valid certificate from an industry-accredited assessment authority regard of flammable refrigerants, which authorizes their competence to handle refrigerants safely in accordance with an industry recognized assessment specification.
- Refrigerant tubing shall be protected or enclosed to avoid damage.

14. Installation

- Flexible refrigerant connectors (such as connecting lines between the indoor and outdoor unit) that may be displaced during normal operations shall be protected against mechanical damage
- Ducts connected to an appliance shall not contain an ignition source.
- A brazed, welded, or mechanical connection shall be made before opening the valves to permit refrigerant to flow between the refrigerating system parts.
- When mechanical connectors are reused indoors, sealing parts shall be renewed.
- When flared joints are reused indoors, the flare part shall be re-fabricated.
- Mechanical connections (mechanical connectors or flared joints) shall be accessible for maintenance purposes.
- The appliance shall be stored in a well-ventilated area where the room size corresponds to the room area as specified for operation.
- The appliance shall be stored in a room without continuously operating ignition sources (for example: open flames, an operating gas appliance or an operating electric heater.)
- The appliance shall be stored so as to prevent mechanical damage from occurring.
- Do not use means to accelerate the defrosting process or to clean, other than those recommended by the manufacturer.
- Do not pierce or burn.
- Be aware that refrigerants may not contain an odour.
- Pipe-work shall be protected from physical damage.

CAUTION

To reduce the risk of minor injury to persons, malfunction, or damage to the product or property when using this product, follow basic precautions, including the following :

- Install at places where it can endure the weight and vibration/noise of the outdoor unit.
- Install the appliance in a place where the noise from the outdoor unit or the exhaust air will not inconvenience the neighbors. Failure to do so may result in conflict with the neighbors.
- Ensure the appliance is installed level. Otherwise, it may cause vibration or water leakage.
- Install the drain hose properly for the smooth drainage of water condensation.
- Do not touch the leaking refrigerant during installation or repair.
- Always check for gas (refrigerant) leakage after installation or repair of appliance.
- Be cautious not to get injured by the sharp edges while installing the appliance or taking it out of its packaging.
- Ensure that you carry by the chassis when you lift the unit.
- This appliance should only be transported by two or more people holding the appliance securely.
- Safely dispose of packing materials such as screws, nails or batteries using proper packaging after installation or repair.
- To avoid nitrogen entering the refrigerant system in a liquid state, the top of the cylinder must be higher than its bottom when you pressurize the system.
- Do not use the appliance for special purposes, such as preserving foods, works of art, and etc. It is an appliance for consumer purposes, not a precision refrigeration system. There is risk of damage or loss of property.

14. Installation

- Do not discharge the refrigerant into the atmosphere.
- If refrigerant leaks, ventilate the room.
- The tubing shall be protected to the extent that it will not be handled or used for carrying during moving of the product.
- Ventilation system have to be installed in the space when appliance with R32 is using for cooling of electric equipment.
- The handling of the refrigerant must comply with national regulations.

14. Installation

Precaution for using R32 refrigerant

- The basic installation work procedures are the same as conventional refrigerant (R410A, R22) models. However, pay careful attention to the following points:
- Please refer to installation and service manual of each appliance for detail.

WARNING

1. Since the working pressure is higher than that of refrigerant R22 models, some of the piping and installation and service tools are special.
Especially, when replacing a refrigerant R22 model with a new refrigerant R32 model, always replace the conventional piping and flare nuts with the R32 and R410A piping and flare nuts on the outdoor unit side.
2. Models that use refrigerant R32 and R410A have a different charging port thread diameter to prevent erroneous charging with refrigerant R22 and for safety.
3. Be more careful than R22 so that foreign matter (oil, water, etc.) does not enter the piping. Also, when storing the piping, securely seal the opening by pinching, taping, etc.

CAUTION

1. Installation (Space)
 - The installation of pipe-work shall be kept to a minimum. Avoid use dented pipe and do not allow acute bending.
 - Pipe-work shall be protected from physical damage.
 - Must comply with national gas regulations, state municipal rules and legislation. Notify relevant authorities in accordance with all applicable regulations.
 - Must ensure mechanical connections be accessible for maintenance purposes.
 - In cases that require mechanical ventilation, ventilation openings shall be kept clear of obstruction.
 - When disposal of the product, do follow to the precautions in #12 and comply with national regulations.
Always contact to local municipal offices for proper handling.
 - Interconnecting refrigerant pipework, i.e. pipework external to the unitary components, should be marked with a Class label every two metres where the pipework is visible. This includes pipework located in a ceiling space or any void which a person may access for maintenance or repair work within that space.
2. Servicing
 - 2-1. Service personnel
 - Any qualified person who is involved with working on or breaking into a refrigerant circuit should hold a current valid certificate from an industry-accredited assessment authority, which authorizes their competence to handle refrigerants safely in accordance with an industry recognized assessment specification.
 - Servicing shall only be performed as recommended by the equipment manufacturer. Maintenance and repair requiring the assistance of other skilled personnel shall be carried out under the supervision of the person competent in the use of flammable refrigerants.
 - Servicing shall be performed only as recommended by the manufacturer.
 - 2-2. Work

14. Installation

- Prior to beginning work on systems containing flammable refrigerants, safety checks are necessary to ensure that the risk of ignition is minimised.
For repair to the refrigerating system, the precautions in #2-2 to #2-8 must be followed before conducting work on the system.

- Work shall be undertaken under a controlled procedure so as to minimize the risk of a flammable gas or vapour being present while the work is being performed.
- All maintenance staff and others working in the local area shall be instructed and supervised on the nature of work being carried out.
- Avoid working in confined spaces.
- Wear appropriate protective equipment, including respiratory protection, as conditions warrant.
- Ensure that the conditions within the area have been made safe by limit of use of any flammable material. Keep all sources of ignition and hot metal surfaces away.

2-3. Checking for presence of refrigerant

- The area shall be checked with an appropriate refrigerant detector prior to and during work, to ensure the technician is aware of potentially flammable atmospheres.
- Ensure that the leak detection equipment being used is suitable for use with flammable refrigerants, i.e. non sparking, adequately sealed or intrinsically safe.
- In case of leakage/spillage happened, immediately ventilate area and stay upwind and away from spill/release.
- In case of leakage/spillage happened, do notify persons downwind of the leaking/spill, isolate immediate hazard area and keep unauthorized personnel out.

2-4. Presence of fire extinguisher

- If any hot work is to be conducted on the refrigeration equipment or any associated parts, appropriate fire extinguishing equipment shall be available at hand.
- Have a dry powder or CO₂ fire extinguisher adjacent to the charging area.

2-5. No ignition sources

- No person carrying out work in relation to a refrigeration system which involves exposing any pipe work that contains or has contained flammable refrigerant shall use any sources of ignition in such a manner that it may lead to the risk of fire or explosion. You must not be smoking when carrying out such work.
- All possible ignition sources, including cigarette smoking, should be kept sufficiently far away from the site of installation, repairing, removing and disposal, during which flammable refrigerant can possibly be released to the surrounding space.
- Prior to work taking place, the area around the equipment is to be surveyed to make sure that there are no flammable hazards or ignition risks.
- “No Smoking” signs shall be displayed.

2-6. Ventilated area

- Ensure that the area is in the open or that it is adequately ventilated before breaking into the system or conducting any hot work.
- A degree of ventilation shall continue during the period that the work is carried out.
- The ventilation should safely disperse any released refrigerant and preferably expel it externally into the atmosphere.

2-7. Checks to the refrigeration equipment

14. Installation

- Where electrical components are being changed, they shall be fit for the purpose and to the correct specification.
- At all times the manufacturer's maintenance and service guidelines shall be followed.
- If in doubt consult the manufacturer's technical department for assistance.
- The following checks shall be applied to installations using flammable refrigerants
 - The actual refrigerant charge is in accordance with the room size within which the refrigerant containing parts are installed.
 - The ventilation machinery and outlets are operating adequately and are not obstructed.
 - If an indirect refrigerating circuit is being used, the secondary circuit shall be checked for the presence of refrigerant.
 - Marking to the equipment continues to be visible and legible. Markings and signs that are illegible shall be corrected.
 - Refrigeration pipe or components are installed in a position where they are unlikely to be exposed to any substance which may corrode refrigerant containing components, unless the components are constructed of materials which are inherently resistant to being corroded or are properly protected against being so corroded.

2-8. Checks to electrical devices

- Repair and maintenance to electrical components shall include initial safety checks and component inspection procedures.
- Initial safety checks shall include but not limit to
 - That capacitors are discharged: this shall be done in a safe manner to avoid possibility of sparking.
 - That there is no live electrical components and wiring are exposed while charging, recovering or purging the system.
 - That there is continuity of earth bonding.
- At all times the manufacturer's maintenance and service guidelines shall be followed.
- If in doubt consult the manufacturer's technical department for assistance.
- If a fault exists that could compromise safety, then no electrical supply shall be connected to the circuit until it is satisfactorily dealt with.
- If the fault cannot be corrected immediately but it is necessary to continue operation, an adequate temporary solution shall be used.
- The owner of the equipment must be informed or reported so all parties are advised thereafter.

Repairs to sealed components

- During repairs to sealed components, all electrical supplies shall be disconnected from the equipment being worked upon prior to any removal of sealed covers, etc.
- If it is absolutely necessary to have an electrical supply to equipment during servicing, then a permanently operating form of leak detection shall be located at the most critical point to warn of a potentially hazardous situation.
- Particular attention shall be paid to the following to ensure that by working on electrical components, the casing is not altered in such a way that the level of protection is affected. This shall include damage to cables, excessive number of connections, terminals not made to original specification, damage to seals, incorrect fitting of glands, etc.
- Ensure that apparatus is mounted securely.
- Ensure that seals or sealing materials have not degraded such that they no longer serve the purpose of preventing the ingress of flammable atmospheres.
- Replacement parts shall be in accordance with the manufacturer's specifications.

14. Installation

Note

The use of silicon sealant may inhibit the effectiveness of some types of leak detection equipment.

Intrinsically safe components do not have to be isolated prior to working on them.

4. Repair to intrinsically safe components

- Do not apply any permanent inductive or capacitance loads to the circuit without ensuring that this will not exceed the permissible voltage and current permitted for the equipment in use.
- Intrinsically safe components are the only types that can be worked on while live in the presence of a flammable atmosphere.
- The test apparatus shall be at the correct rating.
- Replace components only with parts specified by the manufacturer. Unspecified parts by manufacturer may result ignition of refrigerant in the atmosphere from a leak.

5. Cabling

- Check that cabling will not be subject to wear, corrosion, excessive pressure, vibration, sharp edges or any other adverse environmental effects.
- The check shall also take into account the effects of aging or continual vibration from sources such as compressors or fans.

6. Detection of flammable refrigerants

- Under no circumstances shall potential sources of ignition be used in the searching or detection of refrigerant leaks.
- A halide torch (or any other detector using a naked flame) shall not be used.

7. Leak detection methods

- Electronic leak detectors shall be used to detect flammable refrigerants, but the sensitivity may not be adequate, or may need recalibration. (Detection equipment shall be calibrated in a refrigerant-free area.)
- Ensure that the detector is not a potential source of ignition and is suitable for the refrigerant used.
- Leak detection equipment shall be set at a percentage of the LFL of the refrigerant and shall be calibrated to the refrigerant employed and the appropriate percentage of gas (25 % maximum) is confirmed.
- Leak detection fluids are suitable for use with most refrigerants but the use of detergents containing chlorine shall be avoided as the chlorine may react with the refrigerant and corrode the copper pipe-work.
- If a leak is suspected, all naked flames shall be removed/extinguished.
- If a leakage of refrigerant is found which requires brazing, all of the refrigerant shall be recovered from the system, or isolated (by means of shut off valves) in a part of the system remote from the leak. Oxygen free nitrogen (OFN) shall then be purged through the system both before and during the brazing process.

8. Removal and evacuation

- When breaking into the refrigerant circuit to make repairs – or for any other purpose – conventional procedures shall be used. However, it is important that best practice is followed since flammability is a consideration.
The following procedure shall be adhered to :

14. Installation

- remove refrigerant → purge the circuit with inert gas → evacuate → purge again with inert gas → open the circuit by cutting or brazing
 - The refrigerant charge shall be recovered into the correct recovery cylinders.
 - The system shall be “flushed” with OFN to render the unit safe.
 - This process may need to be repeated several times.
 - Compressed air or oxygen shall not be used for this task.
 - Flushing shall be achieved by breaking the vacuum in the system with OFN and continuing to fill until the working pressure is achieved, then venting to atmosphere, and finally pulling down to a vacuum.
 - This process shall be repeated until no refrigerant is within the system.
 - When the final OFN charge is used, the system shall be vented down to atmospheric pressure to enable work to take place.
 - This operation is absolutely vital if brazing operations on the pipe work are to take place.
 - Ensure that the outlet for the vacuum pump is not close to any ignition sources and there is ventilation available.
9. Charging procedures
- In addition to conventional charging procedures, the following requirements shall be followed.
 - Ensure that contamination of different refrigerants does not occur when using charging equipment.
 - Hoses or lines shall be as short as possible to minimize the amount of refrigerant contained in them.
 - Cylinders shall be kept upright.
 - Ensure that the refrigeration system is earthed prior to charging the system with refrigerant.
 - Label the system when charging is complete (if not already).
 - Extreme care shall be taken not to over fill the refrigeration system.
 - Prior to recharging the system it shall be pressure tested with OFN (refer to #7).
 - The system shall be leak tested on completion of charging but prior to commissioning.
 - A follow up leak test shall be carried out prior to leaving the site.
 - Electrostatic charge may accumulate and create a hazardous condition when charging and discharging the refrigerant. To avoid fire or explosion, dissipate static electricity during transfer by grounding and bonding containers and equipment before charging/discharging.
10. Decommissioning
- Before carrying out this procedure, it is essential that the technician is completely familiar with the equipment and all its details.
 - It is recommended good practice that all refrigerants are recovered safely.
 - Prior to the task being carried out, an oil and refrigerant sample shall be taken in case analysis is required prior to re-use of reclaimed refrigerant.

14. Installation

- It is essential that electrical power is available before the task is commenced.
 - a. Become familiar with the equipment and its operation.
 - b. Isolate system electrically.
 - c. Before attempting the procedure ensure that :
 - mechanical handling equipment is available, if required, for handling refrigerant cylinders
 - all personal protective equipment is available and being used correctly
 - the recovery process is supervised at all times by a competent person
 - recovery equipment and cylinders conform to the appropriate standards
 - d. Pump down refrigerant system, if possible.
 - e. If a vacuum is not possible, make a manifold so that refrigerant can be removed from various parts of the system.
 - f. Make sure that cylinder is situated on the scales before recovery takes place.
 - g. Start the recovery machine and operate in accordance with manufacturer's instructions.
 - h. Do not over fill cylinders. (No more than 80 % volume liquid charge).
 - i. Do not exceed the maximum working pressure of the cylinder, even temporarily.
 - j. When the cylinders have been filled correctly and the process completed, make sure that the cylinders and the equipment are removed from site promptly and all isolation valves on the equipment are closed off.
 - k. Recovered refrigerant shall not be charged into another refrigeration system unless it has been cleaned and checked.
- Electrostatic charge may accumulate and create a hazardous condition when charging or discharging the refrigerant. To avoid fire or explosion, dissipate static electricity during transfer by grounding and bonding containers and equipment before charging/discharging.

11. Labelling

- Equipment shall be labelled stating that it has been de-commissioned and emptied of refrigerant.
- The label shall be dated and signed.
- Ensure that there are labels on the equipment stating the equipment contains flammable refrigerant.

12. Recovery

- When removing refrigerant from a system, either for servicing or decommissioning, it is recommended good practice that all refrigerants are removed safely.
- When transferring refrigerant into cylinders, ensure that only appropriate refrigerant recovery cylinders are employed.
- Ensure that the correct number of cylinders for holding the total system charge are available.
- All cylinders to be used are designated for the recovered refrigerant and labelled for that refrigerant (i.e. special cylinders for the recovery of refrigerant).
- Cylinders shall be complete with pressure relief valve and associated shut-off valves in good working order.
- Recovery cylinders are evacuated and, if possible, cooled before recovery occurs.

14. Installation

- The recovery equipment shall be in good working order with a set of instructions concerning the equipment that is at hand and shall be suitable for the recovery of flammable refrigerants.
- In addition, a set of calibrated weighing scales shall be available and in good working order.
- Hoses shall be complete with leak-free disconnect couplings and in good condition.
- Before using the recovery machine, check that it is in satisfactory working order, has been properly maintained and that any associated electrical components are sealed to prevent ignition in the event of a refrigerant release. Consult manufacturer if in doubt.
- The recovered refrigerant shall be returned to the refrigerant supplier in the correct recovery cylinder, and the relevant Waste Transfer Note arranged.
- Do not mix refrigerants in recovery units and especially not in cylinders.
- If compressors or compressor oils are to be removed, ensure that they have been evacuated to an acceptable level to make certain that flammable refrigerant does not remain within the lubricant.
- The evacuation process shall be carried out prior to returning the compressor to the suppliers.
- Only electric heating to the compressor body shall be employed to accelerate this process.
- When oil is drained from a system, it shall be carried out safely.

14. Installation

14.2 Product Overview

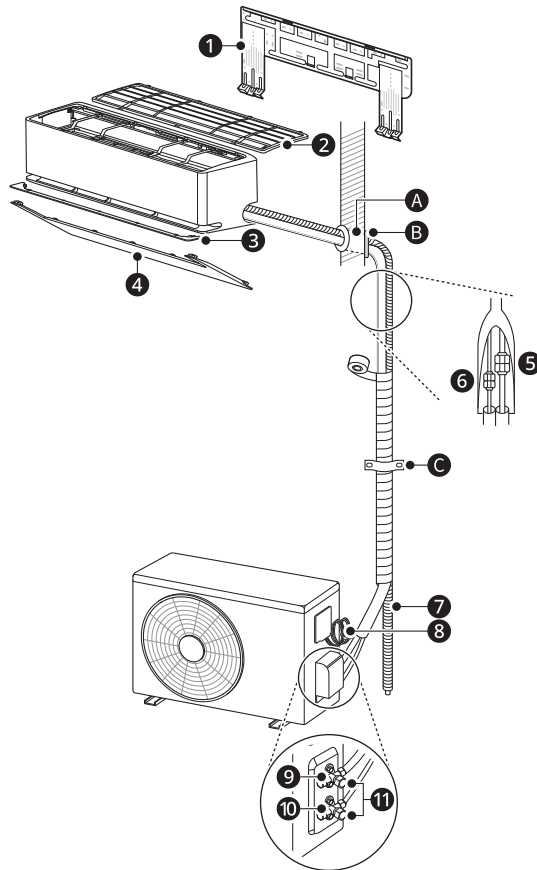

Parts

1	Installation Plate	7	Drain Hose
2	Air Filter	8	Power Supply Cable
3	Air Guide	9	Gas Service Valve
4	Decor	10	Liquid Service Valve
5	Gas Pipe (Larger Pipe)	11	(Gas/Liquid) Service Valve Cap
6	Liquid Pipe (Smaller Pipe)		

Local Purchases

It is highly recommended that you install the following parts.

A	Sleeve
B	Sealant
C	Clamp

Note

- This feature could be different depending on models.
- If needed, additional pipes, drain hoses, and power cables must be purchased separately.

14. Installation

The minimum installation floor area for wall mounted products using R32

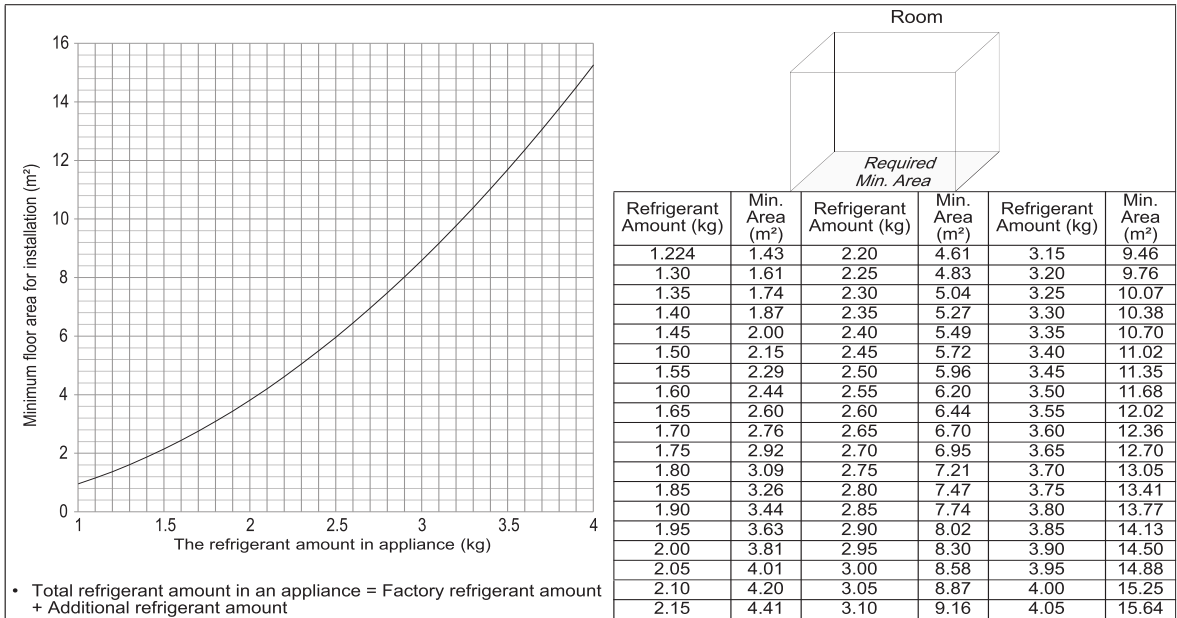

⚠ WARNING

The outdoor unit should be installed in a well-ventilated area or outside.

Determine the case applicable based on the relationship of the refrigerant charge (M) and m_1, m_2, m_3 , defined as follows :

Case	Refrigerant Charge Amount	Requirements
1	$M \leq m_1$	No limit for floor area to install an appliance
2	$m_1 < M \leq m_2$	Need a minimum floor area to install an appliance in accordance with a formula
3	$m_2 < M \leq m_3$	Need a minimum floor area to install an appliance in accordance with a formula Need an additional equipment (Ventilation, shut-off valve, alarm etc.)

$$m_1 = (4 \text{ m}^3) \times \text{LFL} = 4 \text{ m}^3 \times 0.306 \text{ kg/m}^3 = 1.244 \text{ kg}$$

$$m_2 = (26 \text{ m}^3) \times \text{LFL} = 26 \text{ m}^3 \times 0.306 \text{ kg/m}^3 = 7.956 \text{ kg}$$

$$m_3 = (130 \text{ m}^3) \times \text{LFL} = 130 \text{ m}^3 \times 0.306 \text{ kg/m}^3 = 39.78 \text{ kg}$$

The maximum charge (m_{\max} kg) in a room

$$m_{\max} = 2.5 \times \text{LFL}^{5/4} \times h_0 \times A^{1/2} = 2.5 \times 0.306^{5/4} \times 1.8 \times A^{1/2}$$

The required minimum floor area (A_{\min} m²) to install an appliance with refrigerant charge (M kg)

$$A_{\min} = (M / (2.5 \times \text{LFL}^{5/4} \times h_0))^2 = (M / (2.5 \times 0.306^{5/4} \times 1.8))^2$$

Symbol

M : The refrigerant charge amount in appliance (kg), The sum of a pre-charge and an additional charge regard of a pipe length

m_{\max} : The allowable maximum charge in a room (kg), The sum of a pre-charge and an additional charge regard of a pipe length

A : The room area (m²)





A_{\min} : The required minimum room area (m²)

h_0 : The installation height of the appliance (m), h_0 is **1.8 m** for wall mounted

LFL : The lower flammable limit (kg/m³), LFL of R32 is **0.306 kg/m³**

14. Installation

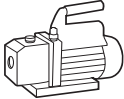
Installation Tools for the products using R32

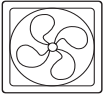
				
Gas Leak Detector	Manifold Gauge	Vacuum Pump	Reclaim Unit	Ventilation Equipment

Note

- Leakage detector which is confirmed rated for use with R32, should be used when you are checking for leaks.
- Under no circumstances shall potential sources of ignition be used in the searching for or detection of refrigerant leaks. A halide torch (or any other detector using a naked flame) shall not be used.
- Ventilation Equipment: For AC system using R32 (A2L gases) a ventilation equipment with “Ex” mark only should be used when a system design exceeds the Lower flammable limit if the gas was to escape from a system.

14. Installation

14.3 Installation Place

Indoor Unit

- Install the indoor unit on a strong and hard wall.
- Install the indoor unit in a spot with good drainage and good accessibility to the pipe connected to the outdoor unit.
- Maintain a clearance of at least ① from the right and left sides of the indoor unit.
- Maintain a clearance of at least ② between the top of the indoor unit and the ceiling.
- Maintain a clearance of at least 2 m (6.5 ft.) from the floor for adequate clearance.
- Do not install the indoor unit near heaters or heating apparatuses.
- Do not install the indoor unit near an obstacle that hinders airflow.
- Do not install the indoor unit near an exit.
- Do not install the indoor unit where it can be exposed to direct sunlight.

14. Installation

Outdoor Unit

- Install the outdoor unit in a location where the floor is firm and even.
- When placing the outdoor unit under an overhang, awning, sunroof or other “roof-like structure”, ensures that heat radiation from the condenser is not restricted around the unit.
- Do not place the unit where animals and/or plants will be in the path of the warm air, or where the warm air and/or noise will disturb neighbors.
- Sunroof is recommended for installations that are exposed to direct sunlight and for installations in cold climates with heavy snow which can accumulate on top of outdoor unit.
- Take the weight of the air conditioner into account and select a place where noise and vibration are minimum.
- Install the outdoor unit somewhere the technician can easily access it for repairs or maintenance.
- Do not install the outdoor unit in a location exposed to saline conditions, such as coastal areas, or sulfuric steam, such as near a hot spring.
- Do not install the outdoor unit in a location exposed to high winds.
- Observe the below clearance requirements.

Note

- Normal clearances are recommended for service and cleaning access.
- If you do not meet the minimum clearances for installation, the unit does not guarantee the reliability of the unit.
- If the outdoor unit is installed between normal and minimum clearances, capacity can be decreased about 10%.

14. Installation

Outdoor unit service access and allowable clearances

Case 1

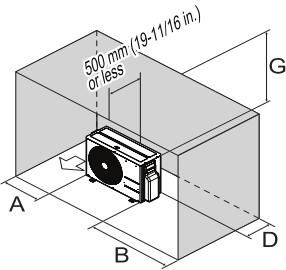

Case 2

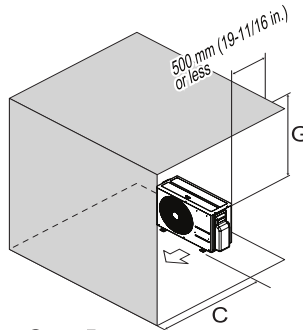

Case 3

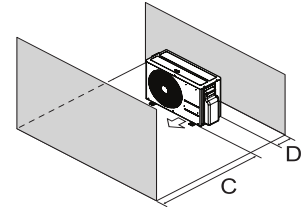

Case 4

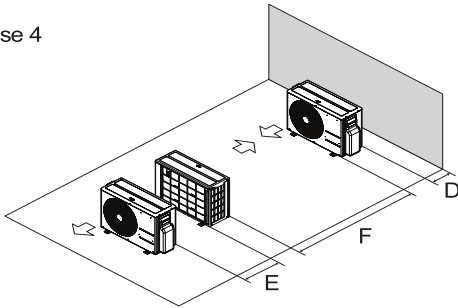

Case 5

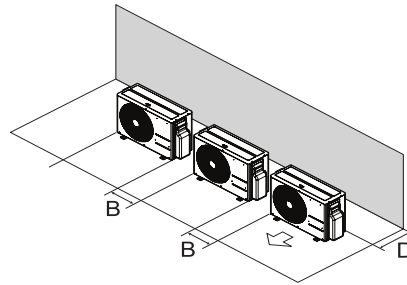

Unit : mm		A	B	C	D	E	F	G
Case1	Normal	300	600	-	300	-	-	-
	Minimum	100	250	-	100	-	-	1000
Case2	Normal	-	-	500	-	-	-	-
	Minimum	-	-	350	-	-	-	1000
Case3	Normal	-	-	500	300	-	-	-
	Minimum	-	-	350	100	-	-	-
Case4	Normal	-	-	-	300	600	-	-
	Minimum	-	-	-	100	200	2000	-
Case5	Normal	-	600	-	300	-	-	-
	Minimum	-	250	-	100	-	-	-

Unit : inch		A	B	C	D	E	F	G
Case1	Normal	11-13/16	23-19/32	-	11-13/16	-	-	-
	Minimum	3-15/16	9-27/32	-	3-15/16	-	-	39-3/8
Case2	Normal	-	-	19-11/16	-	-	-	-
	Minimum	-	-	13-25/32	-	-	-	39-3/8
Case3	Normal	-	-	19-11/16	11-13/16	-	-	-
	Minimum	-	-	13-25/32	3-15/16	-	-	-
Case4	Normal	-	-	-	11-13/16	23-19/32	-	-
	Minimum	-	-	-	3-15/16	7-7/8	78-3/4	-
Case5	Normal	-	23-19/32	-	11-13/16	-	-	-
	Minimum	-	9-27/32	-	3-15/16	-	-	-

14. Installation

Precautions about installation in regions with extreme snowfall and cold temperatures

To ensure the outdoor unit operates properly, certain measures are required in locations where there is a possibility of heavy snowfall or severe wind chill or cold :

- Prepare for severe winter wind chills and heavy snowfall, even in areas of the country where these are unusual phenomena.
- Position the outdoor unit so that its airflow fans are not buried by direct, heavy snowfall. If snow piles up and blocks the airflow, the system may malfunction.
- Remove any snow that has accumulated 100 mm (4 in.) or more on the top of the outdoor unit.
- Place the outdoor unit on a raised platform at least 500 mm (20 inches) higher than the average annual snowfall for the area. If the frame width is wider than the outdoor unit, snow may accumulate.
- Install a snow protection hood.
- To prevent snow and heavy rain from entering the outdoor unit, install the suction and discharge ducts facing away from direct winds.
- Additionally, the following conditions should be taken into consideration when the unit operates in defrost mode :
If the outdoor unit is installed in a highly humid environment (near an ocean, lake, etc.), ensure that the site is well ventilated and has a lot of natural light. (Example : Install on a rooftop.)

14. Installation

14.4 Installing the Outdoor Unit

Fixing the Outdoor Unit with Bolt Construction Work

Fix the outdoor unit firmly to prevent it from falling and dropping.

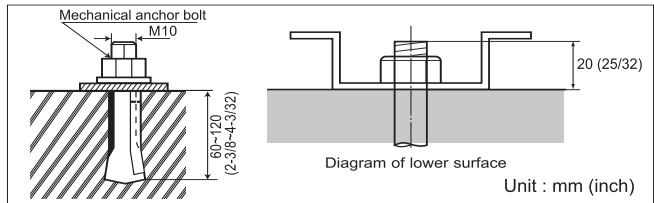
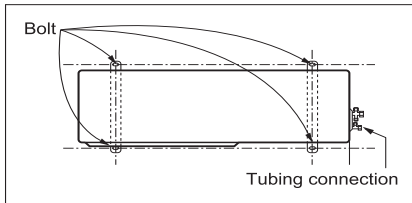

Note

- If you install the outdoor unit on a wall, roof, or rooftop, make sure it's mounted on a suitable frame.
- If the outdoor unit vibrates excessively, secure it using anti-vibration rubber between the unit's feet and the mounting frame.

Foundation

For good drain of outdoor unit, keep the bottom height from icing upward.

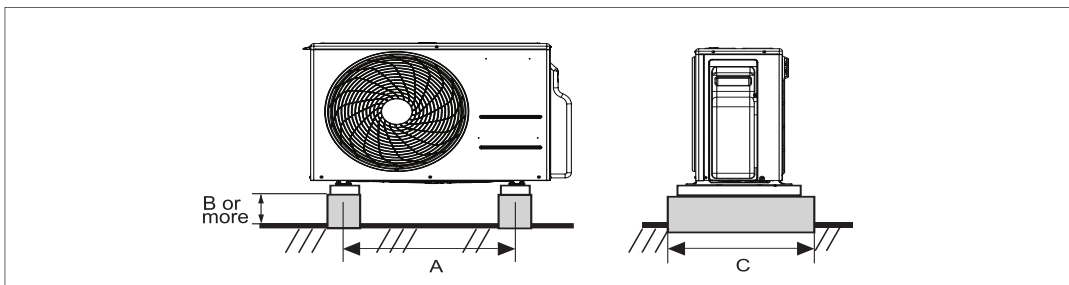

Unit : mm		Foundation			Leg	
Model	Tool	A	B	C	Material	Thickness
P12SND.U12A	U12A	463	100	280	SAZCC	1.6

Unit : inch		Foundation			Leg	
Model	Tool	A	B	C	Material	Thickness
P12SND.U12A	U12A	18-7/32	3-15/16	11-1/32	SAZCC	3/32

14. Installation

Connecting the Drain Plug

If you need to install a drain hose onto an outdoor unit, connect the drain hose after inserting the drain plug with drain washer through the drain hole on the bottom of the outdoor unit.



A : Drain Plug



B : Drain Cap



C : Drain Washer

Note

- If the hole is not in use, block it with the drain cap.
- The quantity and position of the drain cap could be different depending on models.
- In cold areas, do not use the drain hose on the outdoor unit because the water drained out from the drain hose can freeze, which may cause malfunctioning by damaging the heat exchanger.

14. Installation

14.5 Checking the Drainage

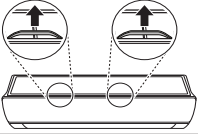
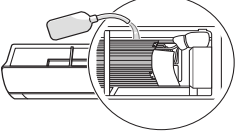
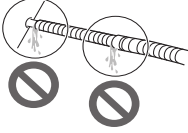
<p>1. Remove the filter.</p> <ul style="list-style-type: none">• Pull the filter up and out towards you.• Do not touch the metal part of the appliance when removing the filter.	
<p>2. Pour a cup of water into the back of the evaporator.</p>	
<p>3. Check the drainage condition.</p> <ul style="list-style-type: none">• Check whether there is any leakage from either the drain hose joint or the extended hose joint.• Check the water is flowing out through the drain hose.• If there is no leakage, but no water is flowing, pour a proper amount of water again.	
<p>4. Insert the filter again.</p>	

Example of Correct Drain Hose Installation

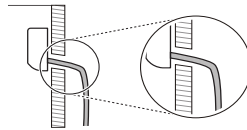

14. Installation

Example of Incorrect Drain Hose Installation

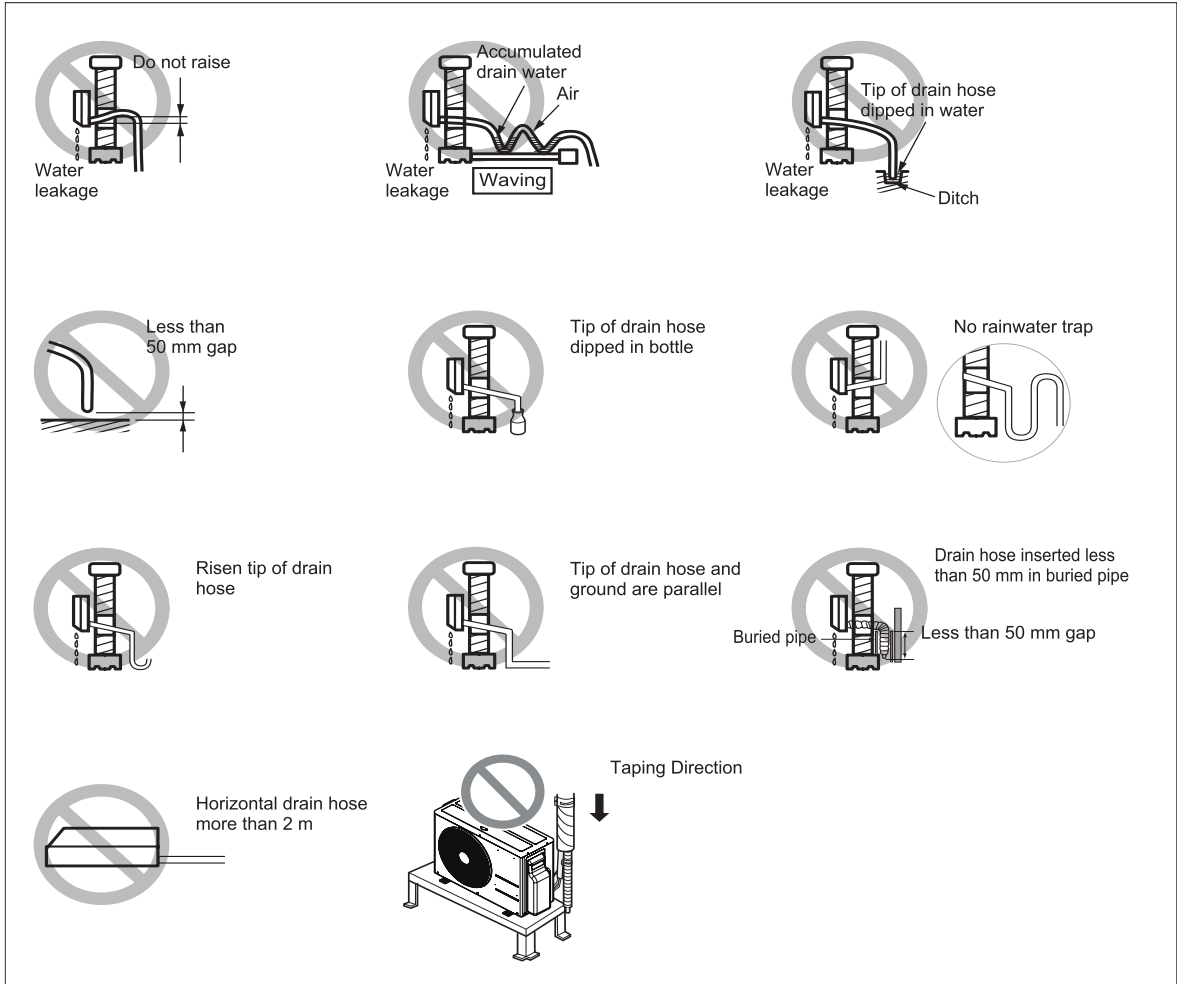

Note

- If the drain hose is not installed properly, water can leak indoors.
 - If the drain hose is installed at a higher position than the indoor unit
 - If the drain hose is entangled or kinked
 - If the end of the drain hose is dipped in water
 - If the gap between the end of the drain hose and the bottom is lower than 50 mm



14. Installation

14.6 Check List and Installer Code

Check test item after installation

No.	Test Items	Check
1	Indoor unit is hooked to the installation plate properly.	
2	The gas and liquid service valves are fully opened.	
3	There is no refrigerant gas leakage.	
4	System is properly grounded. (No electrical leakage)	
5	The connection cable is clamped firmly.	
6	Indoor unit receives remote control commands and operates properly.	
7	Cooling/Heating operation is normal.	
8	There is no abnormal sound.	
9	There is no water leakage.	

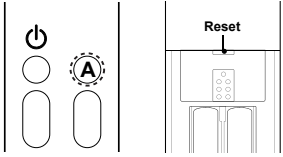
How to set the installer code

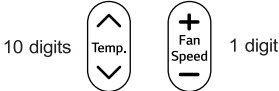
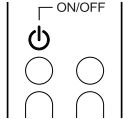
1	Supply the power to the appliance which is turned off.	-
2	(Method I) Insert a battery with pressing (A) button. (Method II) Press " Reset " with pressing (A) button.	
3	Release (A) button. Then, a display of remote controller change to "00".	
4	You can set the code by pressing the " Temp " and " Fan Speed " button.	
5	Press " ON/OFF " button to set a code to the appliance. Check buzzer beep.	
6	(Method I) Take out a battery and insert it again. (Method II) Press " Reset " to return to a user mode.	-
7	Cut the power to the appliance. Turn back on the power to the appliance after 30 seconds.	-

14. Installation

14.7 Outdoor Unit Cabin

Outdoor cabin louver requirement

1. Outdoor cabin type : Manual door open type
2. Louver angle : Less than 15° on the horizontal base
3. Louver interval: Over 100 mm (3-15/16 inch) (Recommend)
4. Louver shape : Wing type or plane type

CAUTION

- Opening rate and suction should be considered for louvered outdoor room.
- Do not use 'S' type louver.

Note

The problem in case the louver opening rate is small.

- Noise can occur due to the increased velocity of the air passing through louver blade.
- Noise can occur due to the louver blade vibrations.
- Drop in outdoor fan performance (Excess static pressure damage can cause drop in the performance as well as outdoor heat exchange efficiency).
- In case the louver opening rate is small or there is insufficient air flow exchange, it might stop the air conditioner.

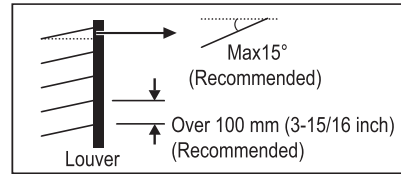

Section

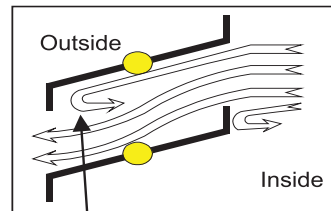

Noise can occur due to the backward flow of the air passing through the louver blade



Opening rate by louver radian

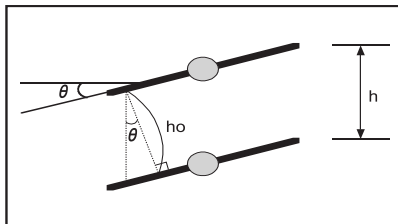

$$\theta \leq 15^\circ$$

$$h_o = h * \text{COS } \theta$$

$$\text{Total face area}(A) = H * W$$

$$\text{Number of open space}(N) = (\text{number of louver} - 1)$$

$$\text{Effective face area}(A_f) = h_o * W * N$$

$$\text{Louver opening rate}(n) = A_f / A$$

$$\therefore A_f = A * n$$

Effective face area of cross section

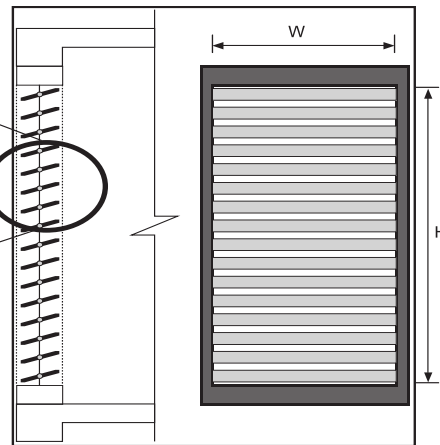

[Side view]

[Front view]

14. Installation

14.8 Outdoor Unit Max External Static Pressure

Model	Tool	Air Flow Rate		Static Pressure	
		CMM	CFM	N / m ²	inWG
P12SND.U12A	U12A	27	954	9.2296	0.0371



Air Solution
<http://hvacepdb.lge.com>
Copyright 2019. LG Electronics Inc. All Rights Reserved.

The air conditioners manufactured by LG have received ISO9001 certificate for quality assurance and ISO14001 certificate for environmental management system. The specifications, designs, and information in this brochure are subject to change without notice.