



INSTALLATION MANUAL

AIR CONDITIONER

Please read this installation manual completely before installing the product.
Installation work must be performed in accordance with the national wiring standards by authorized personnel only.
Please retain this installation manual for future reference after reading it thoroughly.
Please read this manual carefully before operating your set and retain it for future reference.

Air Cooled Liquid Chilling Package
KCHH Series
Original instruction



MFL67262630
Rev.00_011025

www.lg.com

Copyright © 2025 LG Electronics Inc. All Rights Reserved.

TIPS FOR SAVING ENERGY

Here are some tips that will help you minimize the power consumption when you use the air conditioner.

You can use your air conditioner more efficiently by referring to the instructions below:

- Do not cool excessively indoors. This may be harmful for your health and may consume more electricity.
- Block sunlight with blinds or curtains while you are operating the air conditioner.
- Keep doors or windows closed tightly while you are operating the air conditioner.
- Adjust the direction of the air flow vertically or horizontally to circulate indoor air.
- Speed up the fan to cool or warm indoor air quickly, in a short period of time.
- Open windows regularly for ventilation as the indoor air quality may deteriorate if the air conditioner is used for many hours.
- Clean the air filter once every 2 weeks. Dust and impurities collected in the air filter may block the air flow or weaken the cooling / dehumidifying functions.

For your records

Staple your receipt to this page in case you need it to prove the date of purchase or for warranty purposes.

Write the model number and the serial number here:

Model number : _____

Serial number : _____

You can find them on a label on the side of each unit.

Dealer's name : _____

Date of purchase : _____

IMPORTANT SAFETY INSTRUCTIONS

READ ALL INSTRUCTIONS BEFORE USING THE APPLIANCE.

Always comply with the following precautions to avoid dangerous situations and ensure peak performance of your product.

! WARNING

It can result in serious injury or death when the directions are ignored.

! CAUTION

It can result in minor injury or product damage when the directions are ignored.



This symbol indicates that this appliance uses a flammable refrigerant. If the refrigerant is leaked and exposure to an external ignition source, there is a risk of fire. (for R32)



This symbol indicates that the Operation Manual should be read carefully.



This symbol indicates that a service personnel should be handling this equipment with reference to the Installation Manual.



This symbol indicates that information is available such as the Operating Manual or Installation Manual.

Use antifreeze products

- When operating in a low-temperature type (water outlet temperature : less than 4 °C), you must inject antifreeze and manage the concentration of the antifreeze at a freezing temperature of -15 °C or less.

Antifreeze concentration standard:

- Ethylene glycol : More than 30%,
- Propylene glycol : More than 35%

Do not use a heating medium other than the specified antifreeze.

- When operating in heating mode with an inlet water temperature below 18°C or water flow rate below 80 LPM, you must inject antifreeze and manage the concentration of the antifreeze at a freezing temperature - 15 °C or less.

Antifreeze concentration standard:

- Ethylene glycol : More than 30%,
- Propylene glycol : More than 35%

Do not use a heating medium other than the specified antifreeze.

- Use ethylene glycol-based and propylene glycol-based antifreeze, and control the concentration of antifreeze at least once a year.
 - Otherwise, it may cause fire or explosion.

 WARNING

- Installation or repairs made by unqualified persons can result in hazards to you and others.
- The information contained in the manual is intended for use by a qualified service technician familiar with safety procedures and equipped with the proper tools and test instruments.
- Failure to carefully read and follow all instructions in this manual can result in equipment malfunction, property damage, personal injury and/or death.

Installation

- Installation is to be performed by qualified personnel who are familiar with local codes and regulations.
 - There is risk of fire, electric shock, explosion, or injury.
- Always install a dedicated circuit and breaker.
 - Improper wiring or installation may cause fire or electric shock.
- For re-installation of the installed product, always contact a dealer or an Authorized Service Center.
 - There is risk of fire, electric shock, explosion, or injury.
- Do not install, remove, or re-install the unit by yourself (customer).
 - There is risk of fire, electric shock, explosion, or injury.

- Prepare for strong wind or earthquake and install the unit at the specified place.
 - Improper installation may cause the unit to topple and result in injury.
- When installing and moving the Product to another site, do not charge it with a different refrigerant from the refrigerant specified on the unit.
 - If a different refrigerant or air is mixed with the original refrigerant, the refrigerant cycle may malfunction and the unit may be damaged.
- Securely install the cover of control box and the panel.
 - If the cover and panel are not installed securely, dust or water may enter the outdoor unit and fire or electric shock may result.
- If the Product is installed in a small room, measures must be taken to prevent the refrigerant concentration from exceeding the safety limit when the refrigerant leaks.
 - Consult the dealer regarding the appropriate measures to prevent the safety limit from being exceeded. Should the refrigerant leak and cause the safety limit to be exceeded, hazards due to lack of oxygen in the room could result.
- Use the correctly rated breaker or fuse.
 - There is risk of fire or electric shock.
- Have all electric work done by a licensed electrician according to regulations and the instructions given in this manual and always use a special circuit.
 - If the power source capacity is inadequate or electric work is performed improperly, electric shock or fire may result.
- There must be no obstruction above the unit.
 - It would deflect discharge air downward where it could be re-circulated back to the inlet of the condenser coil. The condenser fans are propeller type and will not operate with ductwork on the fan outlet.
- When transporting the product, use the forklift or spreader bar in accordance with the manual.
 - Arbitrarily moving the product can cause product damage or injury.

- When moving the product using the forklift, check the weight of the chiller, size and length of the fork to select the appropriate equipment.
 - It can cause damage or injury.
- When hanging the product on the hoist to move the chiller, make sure that the load of the product is evenly distributed and leveled during the move.
 - It can cause damage or injury.
- When moving the product using the spreader bar, make sure to select the spreader bar with material and size to sufficiently support the strength spreader bar.
 - Using inappropriate spreader bar can cause the product to fall and cause injury due to the strength or size.
- Always ground the product.
 - There is risk of fire or electric shock.
- Do not store or use flammable gas or combustibles near the Product.
 - There is risk of fire or failure of product.
- Do not reconstruct to change the settings of the protection devices.
 - If the pressure switch, thermal switch, or other protection device is shorted and operated forcibly, or parts other than those specified by LGE are used, fire or explosion may result.
- Ventilate before operating Product when gas leaked out.
 - It may cause explosion, fire, and burn.
- Use a vacuum pump or Inert (nitrogen) gas when doing leakage test or air purge. Do not compress air or Oxygen and Do not use Flammable gases. Otherwise, it may cause fire or explosion.
 - There is the risk of death, injury, fire or explosion.
- Do not install the unit in potentially explosive atmospheres.
- After installing or inspecting the product, make sure to lock the door with the key.
 - The door must be locked when the product is connected to power.
 - The appliance shall be stored in a room without continuously operating open flames (for example an operating gas appliance) and ignition sources (for example an operating electric heater).

Use

- Do not damage or use an unspecified POWER CABLE.
 - There is risk of fire, electric shock, explosion, or injury.
- Use a dedicated outlet for this appliance.
 - There is risk of fire or electrical shock.
- Be cautious that water could not enter the Product.
 - There is risk of fire, electric shock, or product damage.
- Do not touch the power switch with wet hands.
 - There is risk of fire, electric shock, explosion, or injury.
- When installing and moving the Product to another site, do not charge it with a different refrigerant from the refrigerant specified on the unit.
 - If a different refrigerant or air is mixed with the original refrigerant, the refrigerant cycle may malfunction and the unit may be damaged.
- When the product is soaked (flooded or submerged), contact an Authorized Service Center.
 - There is risk of fire or electric shock.
- Be cautious not to touch the sharp edges and coil.
 - It may cause injury.
- Take care to ensure that nobody could step on or fall onto the outdoor unit.
 - This could result in personal injury and product damage.
- Do not open the inlet grille of the product during operation. (Do not touch the electrostatic filter, if the unit is so equipped.)
 - There is risk of physical injury, electric shock, or product failure.
- Be careful during valve checkout about hot gas line
 - It may become hot enough to cause injury.
- Electric shock hazard. Can cause severe injury or death. Even when power to the panel is off, output board could be connected to high voltage.
- Electric shock hazard. Turn off all power before doing any service.
- Turn the main power off in case of installation or service.
- Means for disconnection must be incorporated in the fixed wiring in accordance with the wiring rules.

- If the supply cord is damaged, it must be replaced by the manufacturer, its service agent or similarly qualified persons in order to avoid a hazard.
- This appliance is not intended to be accessible to the general public.

CAUTION

Installation

- Always check for gas (refrigerant) leakage after installation or repair of product.
 - Low refrigerant levels may cause failure of product.
- Do not install the product where the noise or hot air from the outdoor unit could damage the neighborhoods.
 - It may cause a problem for your neighbors.
- Keep level even when installing the product.
 - To avoid vibration or water leakage.
- Do not install the unit where combustible gas may leak.
 - If the gas leaks and accumulates around the unit, an explosion may result.
- Do not install the product where it is exposed to sea wind (salt spray) directly.
 - It may cause corrosion on the product. Corrosion, particularly on the condenser and evaporator fins, could cause product malfunction or inefficient operation.
- When installing the unit in a hospital, communication station, or similar place, provide sufficient protection against noise.
 - The inverter equipment, private power generator, high-frequency medical equipment, or radio communication equipment may cause the Product to operate erroneously, or fail to operate. On the other hand, the Product may affect such equipment by creating noise that disturbs medical treatment or image broadcasting.
- This equipment is intended for use in industrial environments and may not provide adequate protection to radio reception in such not environments.

- Use power cables of sufficient current carrying capacity and rating.
 - Cables that are too small may leak, generate heat, and cause a fire.
- Do not use the product for special purposes, such as preserving foods, works of art, etc. It is a consumer Product, not a precision refrigeration system.
 - There is risk of damage or loss of property.
- Keep the unit away from children. The heat exchanger is very sharp.
 - It can cause the injury, such as cutting the finger. Also the damaged fin may result in degradation of capacity.
- The operator must provide protection against water circuit freezing on all Product units.
 - To prevent damage from freezing water.
- If anyone other than a licensed Professional installs, repairs, or alters LG Electronics Air Conditioning Products, the warranty is voided.
 - All costs associated with repair are then the full responsibility of the owner.
- Do not install the unit in potentially explosive atmospheres.
- Parts of the appliance are suitable for outdoor use.

Use

- Do not use the Product in special environments.
 - Oil, steam, sulfuric smoke, etc. can significantly reduce the performance of the Product or damage its parts.
- Make the connections securely so that the outside force of the cable may not be applied to the terminals.
 - Inadequate connection and fastening may generate heat and cause a fire.
- Be sure the installation area does not deteriorate with age.
 - If the base collapses, the Product could fall with it, causing property damage, product failure, or personal injury.

- Install and insulate the drain hose to ensure that water is drained away properly based on the installation manual.
 - A bad connection may cause water leakage.
- Be very careful about product transportation.
 - Do not touch the heat exchanger fins. Doing so may cut your fingers.
 - When transporting the outdoor unit, suspending it at the specified positions on the unit base. Also support the outdoor unit at four points so that it cannot slip sideways.
- Safely dispose of the packing materials.
 - Packing materials, such as nails and other metal or wooden parts, may cause stabs or other injuries.
 - Tear apart and throw away plastic packaging bags so that children may not play with them. If children play with a plastic bag which was not torn apart, they face the risk of suffocation.
- Turn on the power at least 6 hours before starting operation.
 - Starting operation immediately after turning on the main power switch can result in severe damage to internal parts. Keep the power switch turned on during the operational season.
- Do not touch any of the refrigerant piping during and after operation.
 - It can cause a burn or frostbite.
- Do not operate the Product with the panels or guards removed.
 - Rotating, hot, or high-voltage parts can cause injuries.
- Do not directly turn off the main power switch after stopping operation.
 - Wait at least 5 minutes before turning off the main power switch. Otherwise it may result in electric shock or other problems.
- When re-running the product after keep product long time in a low temperature conditions, touch function may not work temporarily.
 - Wait for a time. After time, product work normally.
- Do not insert hands or other objects through the air inlet or outlet while the Product is plugged in.
 - There are sharp and moving parts that could cause personal injury.

- Field wiring must be installed according to unit wiring diagram.
 - It may cause serious electrical damage can occur.
- When the outdoor temperature in season below 5 °C, take measures to prevent freezing of water pipes.
 - Freeze protection measures such as antifreeze injection, heater operation, and pump operation are required.
- When disposing of antifreeze or cleaning fluid, please dispose of it in accordance with relevant laws and regulations.
 - Disposal without complying with relevant laws may adversely affect the environment or health.
- Do not use an automotive antifreeze. Industrial grade glycols must be used. Automotive antifreeze contains inhibitors which will cause plating on the copper tubes within the Product evaporator. The type and handling of glycol used must be consistent with local codes.
- Electrical power must be applied to the compressor crankcase heaters 6 hours before starting unit to drive off refrigerant from the oil.
- Any changes to these parameters must be determined and implemented by qualified personnel with a thorough understanding of how these parameters affect the operation of the unit. Negligent or improper adjustment of these controls can result in damage to the unit or personal injury.
- Service on this equipment is to be performed by qualified refrigeration personnel familiar with equipment operation, maintenance, correct servicing procedures, and the safety hazards inherent in this work. Causes for repeated tripping of equipment protection controls must be investigated and corrected.
- This appliance is not intended for use by persons (including children) with reduced physical, sensory or mental capabilities or lack of experience and knowledge, unless they have been given supervision or instruction concerning use of the appliance by a person responsible for their safety.
Children should be supervised to ensure that they do not play with the appliance.

- This appliance can be used by children aged from 8 years and above and persons with reduced physical, sensory or mental capabilities or lack of experience and knowledge if they have been given supervision or instruction concerning use of the appliance in a safe way and understand the hazards involved. Children shall not play with the appliance. Cleaning and user maintenance shall not be made by children without supervision.
- User must carry routine checkup & cleaning to avoid unit's poor performance. In case of special situation, the job must be carried out by service person only.
- This appliance incorporates an earth connection for functional purposes only.

Safety precautions for R32 model

- Do not use means to accelerate the defrosting process or to clean, other than those recommended by the manufacturer.
- The appliance shall be stored in a well-ventilated area where the room size corresponds to the room area as specified for operation
- The appliance shall be stored in a room without continuously operating open flames (for example an operating gas appliance) and ignition sources (for example an operating electric heater).
- Do not pierce or burn.
- Be aware that refrigerants may not contain an odour.
- Keep any required ventilation openings clear of obstruction
- The appliance shall be stored so as to prevent mechanical damage from occurring. The manufacturer should specify other potential continuously operating sources known to cause ignition of the refrigerant used.
- Compliance with national gas regulations shall be observed
- Refrigerant tubing shall be protected or enclosed to avoid damage.

- The installation of pipe-work shall be kept to a minimum.
- A brazed, welded, or mechanical connection shall be made before opening the valves to permit refrigerant to flow between the refrigerating system parts.
- Any person who is involved with working on or breaking into a refrigerant circuit should hold a current valid certificate from an industry-accredited assessment authority, which authorises their competence to handle refrigerants safely in accordance with an industry recognised assessment specification.
- Servicing shall only be performed as recommended by the equipment manufacturer.
Maintenance and repair requiring the assistance of other skilled personnel shall be carried out under the supervision of the person competent in the use of flammable refrigerants.
- Periodic cleaning of the dust of salt particles stuck on the heat exchanger by using water.
- Dismantling the unit, treatment of the refrigerant oil and eventual parts should be done in accordance with local and national standards.

Checks to the area

Prior to beginning work on systems containing flammable refrigerants, safety checks are necessary to ensure that the risk of ignition is minimised. For repair to the refrigerating system, the following precautions shall be complied with prior to conducting work on the system.

Work procedure

Work shall be undertaken under a controlled procedure so as to minimise the risk of a flammable gas or vapour being present while the work is being performed.

General work area

All maintenance staff and others working in the local area shall be instructed on the nature of work being carried out. Work in confined spaces shall be avoided.

Checking for presence of refrigerant

The area shall be checked with an appropriate refrigerant detector prior to and during work, to ensure the technician is aware of potentially flammable atmospheres. Ensure that the leak detection equipment being used is suitable for use with flammable refrigerants, i.e. non-sparking, adequately sealed or intrinsically safe.

Presence of fire extinguisher

If any hot work is to be conducted on the refrigerating equipment or any associated parts, appropriate fire extinguishing equipment shall be available to hand. Have a dry powder or CO₂ fire extinguisher adjacent to the charging area.

No ignition sources

No person carrying out work in relation to a refrigerating system which involves exposing any pipe work that contains or has contained flammable refrigerant shall use any sources of ignition in such a manner that it may lead to the risk of fire or explosion.

All possible ignition sources, including cigarette smoking, should be kept sufficiently far away from the site of installation, repairing, removing and disposal, during which flammable refrigerant can possibly be released to the surrounding space.

Prior to work taking place, the area around the equipment is to be surveyed to make sure that there are no flammable hazards or ignition risks. "No Smoking" signs shall be displayed.

Checks to the refrigerating equipment

Where electrical components are being changed, they shall be fit for the purpose and to the correct specification. At all times the manufacturer's maintenance and service guidelines shall be followed. If in doubt consult the manufacturer's technical department for assistance.

The following checks shall be applied to installations using flammable refrigerants:

- The actual refrigerant charge is in accordance with the room size within which the refrigerant containing parts are installed
- The ventilation machinery and outlets are operating adequately and are not obstructed
- If an indirect refrigerating circuit is being used, the secondary circuit shall be checked for the presence of refrigerant
- Marking to the equipment continues to be visible and legible. Markings and signs that are illegible shall be corrected
- Refrigerating pipe or components are installed in a position where they are unlikely to be exposed to any substance which may corrode refrigerant containing components, unless the components are constructed of materials which are inherently resistant to being corroded or are suitably protected against being so corroded.

Checks to electrical devices

Repair and maintenance to electrical components shall include initial safety checks and component inspection procedures.

If a fault exists that could compromise safety, then no electrical supply shall be connected to the circuit until it is satisfactorily dealt with.

If the fault cannot be corrected immediately but it is necessary to continue operation, an adequate temporary solution shall be used. This shall be reported to the owner of the equipment so all parties are advised.

Initial safety checks shall include:

- Capacitors are discharged: this shall be done in a safe manner to avoid possibility of sparking.
- No live electrical components and wiring are exposed while charging, recovering or purging the system.
- Continuity of earth bonding

Repairs to sealed components

During repairs to sealed components, all electrical supplies shall be disconnected from the equipment being worked upon prior to any removal of sealed covers, etc.

If it is absolutely necessary to have an electrical supply to equipment during servicing, then a permanently operating form of leak detection shall be located at the most critical point to warn of a potentially hazardous situation.

Particular attention shall be paid to the following to ensure that by working on electrical components, the casing is not altered in such a way that the level of protection is affected.

This shall include damage to cables, excessive number of connections, terminals not made to original specification, damage to seals, incorrect fitting of glands, etc.

Ensure that apparatus is mounted securely.

Ensure that seals or sealing materials have not degraded such that they no longer serve the purpose of preventing the ingress of flammable atmospheres.

Replacement parts shall be in accordance with the manufacturer's specifications.

Repair to intrinsically safe components

Do not apply any permanent inductive or capacitance loads to the circuit without ensuring that this will not exceed the permissible voltage and current permitted for the equipment in use.

Intrinsically safe components are the only types that can be worked on while live in the presence of a flammable atmosphere. The test apparatus shall be at the correct rating. Replace components only with parts specified by the manufacturer.

Other parts may result in the ignition of refrigerant in the atmosphere from a leak.

NOTE

The use of silicon sealant can inhibit the effectiveness of some types of leak detection equipment. Intrinsically safe components do not have to be isolated prior to working on them.

Decommissioning

Before carrying out this procedure, it is essential that the technician is completely familiar with the equipment and all its detail.

It is recommended good practice that all refrigerants are recovered safely.

Prior to the task being carried out, an oil and refrigerant sample shall be taken in case analysis is required prior to re-use of recovered refrigerant. It is essential that electrical power is available before the task is commenced.

- a) Become familiar with the equipment and its operation.
- b) Isolate system electrically.

- c) Before attempting the procedure ensure that:
- Mechanical handling equipment is available, if required, for handling refrigerant cylinders
 - All personal protective equipment is available and being used correctly
 - The recovery process is supervised at all times by a competent person
 - Recovery equipment and cylinders conform to the appropriate standards.
- d) Pump down refrigerant system, if possible.
- e) If a vacuum is not possible, make a manifold so that refrigerant can be removed from various parts of the system.
- f) Make sure that cylinder is situated on the scales before recovery takes place.
- g) Start the recovery machine and operate in accordance with manufacturer's instructions.
- h) Do not overfill cylinders. (No more than 80 % volume liquid charge).
- i) Do not exceed the maximum working pressure of the cylinder, even temporarily.
- j) When the cylinders have been filled correctly and the process completed, make sure that the cylinders and the equipment are removed from site promptly and all isolation valves on the equipment are closed off.
- k) Recovered refrigerant shall not be charged into another refrigerating system unless it has been cleaned and checked.

Labelling

Equipment shall be labelled stating that it has been de-commissioned and emptied of refrigerant. The label shall be dated and signed. Ensure that there are labels on the equipment stating the equipment contains flammable refrigerant.

Ventilated area

Ensure that the area is in the open or that it is adequately ventilated before breaking into the system or conducting any hot work. A degree of ventilation shall continue during the period that the work is carried out. The ventilation should safely disperse any released refrigerant and preferably expel it externally into the atmosphere.

Cabling

Cabling will not be subject to wear, corrosion, excessive pressure, vibration, sharp edges or any other adverse environmental effects. The check shall also take into account the effects of ageing or continual vibration from sources such as compressors or fans.

Detection of flammable refrigerants

Under no circumstances shall potential sources of ignition be used in the searching for or detection of refrigerant leaks. A halide torch (or any other detector using a naked flame) shall not be used.

Leak detection methods

The following leak detection methods are deemed acceptable for systems containing flammable refrigerants.

Electronic leak detectors shall be used to detect flammable refrigerants, but the sensitivity may not be adequate, or may need re-calibration. (Detection equipment shall be calibrated in a refrigerant-free area.)

Ensure that the detector is not a potential source of ignition and is suitable for the refrigerant used.

Leak detection equipment shall be set at a percentage of the LFL of the refrigerant and shall be calibrated to the refrigerant employed and the appropriate percentage of gas (25 % maximum) is confirmed.

Leak detection fluids are also suitable for use with most refrigerants but the use of detergents containing chlorine shall be avoided as the chlorine may react with the refrigerant and corrode the copper pipe-work.

NOTE

Examples of leak detection fluids are

- bubble method
- fluorescent method agents

If a leak is suspected, all naked flames shall be removed/extinguished.

If a leakage of refrigerant is found which requires brazing, all of the refrigerant shall be recovered from the system, or isolated (by means of shut off valves) in a part of the system remote from the leak. Removal of refrigerant shall be according to removal and evacuation procedure.

Removal and evacuation

When breaking into the refrigerant circuit to make repairs - or for any other purpose - conventional procedures shall be used. However, for flammable refrigerants it is important that best practice be followed, since flammability is a consideration.

The following procedure shall be adhered to:

- a) safely remove refrigerant following local and national regulations;
- b) purge the circuit with inert gas;
- c) evacuate (optional for A2L);
- d) purge with inert gas (optional for A2L);
- e) open the circuit by cutting or brazing.

The refrigerant charge shall be recovered into the correct recovery cylinders if venting is not allowed by local and national codes.

For appliances containing flammable refrigerants, the system shall be purged with oxygen-free nitrogen to render the appliance safe for flammable refrigerants. This process might need to be repeated several times. Compressed air or oxygen shall not be used for purging refrigerant systems.

For appliances containing flammable refrigerants, refrigerants purging shall be achieved by breaking the vacuum in the system with oxygen-free nitrogen and continuing to fill until the working pressure is achieved, then venting to atmosphere, and finally pulling down to a vacuum (optional for A2L).

This process shall be repeated until no refrigerant is within the system (optional for A2L).

When the final oxygen-free nitrogen charge is used, the system shall be vented down to atmospheric pressure to enable work to take place.

Ensure that the outlet for the vacuum pump is not close to any potential ignition sources and that ventilation is available.

Charging procedures

In addition to conventional charging procedures, the following requirements shall be followed.

- Ensure that contamination of different refrigerants does not occur when using charging equipment. Hoses or lines shall be as short as possible to minimise the amount of refrigerant contained in them.
- Cylinders shall be kept in an appropriate position according to the instruction.
- Ensure that the refrigerating system is earthed prior to charging the system with refrigerant.
- Label the system when charging is complete (if not already).
- Extreme care shall be taken not to overfill the refrigerating system.

Prior to recharging the system, it shall be pressure tested with the appropriate purging gas.

The system shall be leak-tested on completion of charging but prior to commissioning. A follow up leak test shall be carried out prior to leaving the site.

Recovery

When removing refrigerant from a system, either for servicing or decommissioning, it is recommended good practice that all refrigerants are removed safely.

When transferring refrigerant into cylinders, ensure that only appropriate refrigerant recovery cylinders are employed.

Ensure that the correct number of cylinders for holding the total system charge are available. All cylinders to be used are designated for the recovered refrigerant and labelled for that refrigerant (i.e. special cylinders for the recovery of refrigerant).

Cylinders shall be complete with pressure relief valve and associated shut-off valves in good working order.

Empty recovery cylinders are evacuated and, if possible, cooled before recovery occurs. The recovery equipment shall be in good working order with a set of instructions concerning the equipment that is at hand and shall be suitable for the recovery of flammable refrigerants. In addition, a set of calibrated weighing scales shall be available and in good working order.

Hoses shall be complete with leak-free disconnect couplings and in good condition. Before using the recovery machine, check that it is in satisfactory working order, has been properly maintained and that any associated electrical components are sealed to prevent ignition in the event of a refrigerant release.

Consult manufacturer if in doubt. The recovered refrigerant shall be returned to the refrigerant supplier in the correct recovery cylinder, and the relevant Waste Transfer Note arranged.

Do not mix refrigerants in recovery units and especially not in cylinders. If compressors or compressor oils are to be removed, ensure that they have been evacuated to an acceptable level to make certain that flammable refrigerant does not remain within the lubricant.

The evacuation process shall be carried out prior to returning the compressor to the suppliers. Only electric heating to the compressor body shall be employed to accelerate this process. When oil is drained from a system, it shall be carried out safely.

Qualification of workers

The manual shall contain specific information about the required qualification of the working personnel for maintenance, service and repair operations. Every working procedure that affects safety means shall only be carried out by competent persons according to Annex HH.

Examples for such working procedures are:

- Breaking into the refrigerating circuit;
- Opening of sealed components;
- Opening of ventilated enclosures.
- Mechanical connections (mechanical connectors or flared joints) shall be accessible for maintenance purposes
- When mechanical connectors are reused indoors, sealing parts shall be renewed.
When flared joints are reused indoors, the flare part shall be re-fabricated.
- If the supply cord is damaged, it must be replaced by the manufacturer, its service agent or similarly qualified persons in order to avoid a hazard.
- Flexible pipe elements shall be protected against mechanical damage, excessive stress by torsion, or other forces. They should be checked for mechanical damage annually.

- Protection devices, piping and fittings shall be protected as far as possible against adverse environmental effects, for example, the danger of water collecting and freezing in relief pipes or the accumulation of dirt and debris.
- Precautions shall be taken to avoid excessive vibration or pulsation to refrigerating piping.
- Piping in refrigerating systems shall be so designed and installed to minimize the likelihood hydraulic shock damaging the system.
- Provision shall be made for expansion and contraction of long runs of piping.
- Steel pipes and components shall be protected against corrosion with a rustproof coating before applying any insulation.
- Servicing shall be performed only as recommended by the manufacturer.
- Piping material, pipe routing, and installation shall include protection from physical damage in operation and service, and be in compliance with national and local codes and standards. All field joints shall be accessible for inspection prior to being covered or enclosed.
- Equipment piping in the occupied space shall be installed in such a way to protect against accidental damage in operation and service
- Solenoid valves shall be correctly positioned in the piping to avoid hydraulic shock.
- This unit is equipped with electrically powered safety measures. To be effective, the unit must be electrically powered at all times after installation, other than when servicing.

TABLE OF CONTENTS

2 TIPS FOR SAVING ENERGY

3 IMPORTANT SAFETY INSTRUCTIONS

26 PRODUCT INTRODUCTION

26 General information

37 CONTROL

37 Control panel configuration

41 Chiller address setting

42 Logging in to HMI

43 Introduction to HMI menu

59 Introduction to schedule menu

67 Introduction to record menu

69 View setting menu

97 FROM INSTALLATION TO TEST RUN

98 INSTALLATION

98 Selecting installation location

105 Transportation method and precaution

108 Installing chiller

112 Snow protection

113 Water pipe connection

124 Electric specification

125 Electric work

129 How to set control box address (Set cycle PCB address)

130 How to install HMI indoors

132 Unit Combination

133 How to set the main controller address

134 TEST RUN

136 ADDITIONAL FUNCTION

139 SELF DIAGNOSIS FUNCTION

141 WATER MANAGEMENT

141 Water pipe side strainer

141 Actions for problems in the test operation

142 Plate type heat exchanger maintenance

143 Daily inspection management

145 TROUBLESHOOTING

155 APPENDIX

PRODUCT INTRODUCTION

General information

Product information

Inverter Scroll Chiller of LG Electronics provides cold water for cooling air conditioning system using AHU or FCU etc. Air Cooled R32 Refrigerant Scroll Chiller KCHH Series designed for outdoors is a single unit product of modular type composed of scroll compressor, air cooled condenser, electronic expansion valve, evaporator and LG HMI (Human Machine Interface).

KCHH Series is composed of 2 inverter compressor to form independent refrigerant cycle and one unit module can configure up to maximum of 3 refrigerant cycles and interlock of 5 modules by using AC Smart controller and up to 10 modules by using ACP.

KCHH Series applies the inverter technology to the compressor and condenser fan motor for not only high load but also highly efficient operation in all operating areas.

HMI controller of KCHH Series has the LG's unique control logic to monitor all parameters controlling the operation. These parameters can be controlled to improve the operational efficiency to continuously supply cold water by optimizing to the environment.

Each refrigerant cycle includes the check valve, electronic expansion valve, strainer and refrigerant charge valve. Evaporator connected to the cold water uses the plate type heat exchanger and the condenser uses the air cooled fin and tube heat exchanger.

Inverter Scroll Chiller is a industrial product.

Model naming convention

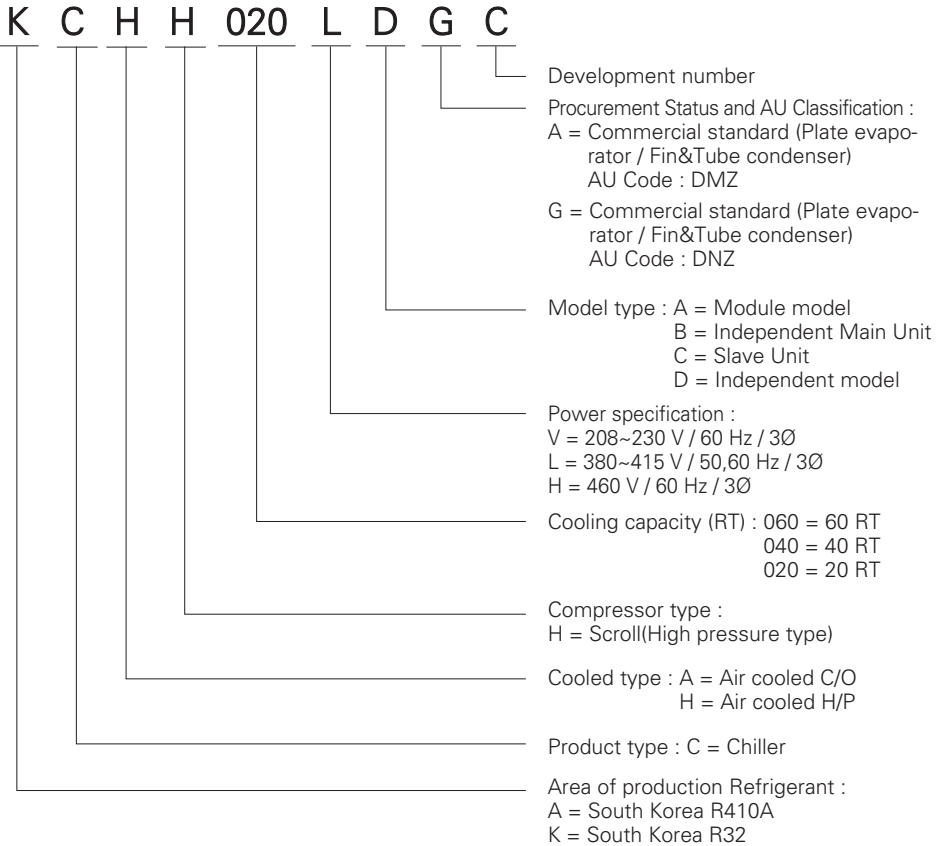

Airborne Noise Emission

The A-weighted sound pressure emitted by this product is below the 70 dB.

** The noise level can vary depending on the site.

The figures quoted are emission level and are not necessarily safe working levels. Whilst there is a correlation between the emission and exposure levels, this cannot be used reliably to determine whether or not further precautions are required. Factor that influence the actual level of exposure of the workforce include the characteristics of the work room and the other sources of noise, i.e. the number of equipment and other adjacent processes and the length of time for which an operator exposed to the noise. Also, the permissible exposure level can vary from country to country. This information, however, will enable the user of the equipment to make a better evaluation of the hazard and risk.

Product configuration

This chiller model is configured as shown below.

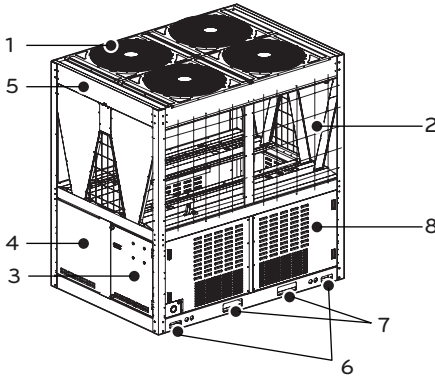

Legend

1. Fan motor
2. Fin & tube heat exchanger
3. Main Controller box
4. Sub Controller box
5. Condenser cover
6. Rope support
7. Forklift groove
8. Side cover

Cooling cycle

KCHH Series uses the high pressure type scroll compressor, and the suction gas part is separated from the high pressure discharge part and the motor is installed on the low pressure gas part. Space for motor and storage for refrigerant is secured in the low pressure gas part to increase the reliability for the liquid compression.

Because the sucked refrigerant gas cools the motor and flows to the compressor, separate cooling device to cool the compressor is not required. Inside the system, oil to lubricate the compressor is mixed with the refrigerant to discharge both the oil and refrigerant during the operation. Because the oil discharged from the compressor can reduce the heat transfer efficiency when thick layer is built up on the inner walls of the condenser and evaporator, device to prevent the refrigerant and oil to be discharged together is added to prevent this issue.

This lubrication system ensures longer life for the compressor, improves the sealing of the compression space and provides low noise operation.

As the air cooled fin and tube type heat exchanger, the condenser is composed of heat exchanger in V shape, and the electronic expansion valve is used for efficient control in all load conditions. The controller used in the chiller is exclusively for LG and monitors various sensors installed on the product to protect the product.

For continuous supply of cold and hot water, the product is equipped with maximum continuous operational function and also provides precision control to supply accurate target amount of cold and hot water.

But the protective devices will immediately stop the product when the product reaches abnormal condition or area limit.

In case of an issue, the controller of the chiller will provide helpful diagnostic message to the administrator.

Description of cooling cycle

The cooling cycle of KCHH Series can be described using the following Pressure – Enthalpy chart.

①, ②, ③, ④ and ⑤ in the following chart shows the conditions of the refrigerant.

The refrigerant comes into the compressor motor and cools the motor, and becomes overheated and moves to the suction inlet of the compressor. The oil inside the compressor seals the gap between the compressor scrolls and provides lubrication for the bearing to help the compression of the refrigerant. During this time, the refrigerant is compressed and is discharged to the air cooled condenser. (②)

The compressed refrigerant passes through the air cooled condenser and exchanges the heat with the outdoor air. The condensed refrigerant then passes the condenser to be overcooled. (② → ③ → ④).

The refrigerant that passed through the condenser expands in the electronic expansion valve to flow to the evaporator. (④ → ⑤).

The refrigerant is evaporated in the plate type heat exchanger, the evaporator. (⑤ → ①)

Liquid refrigerant of low temperature pressure passes through the evaporator to cool the water flowing into the evaporator and the refrigerant itself receives the heat to evaporate to gas condition. (①)

The refrigerant continues to change the phase and continuously repeats the cooling cycle. For heating, the refrigerant flows in the reverse direction to provide hot water.

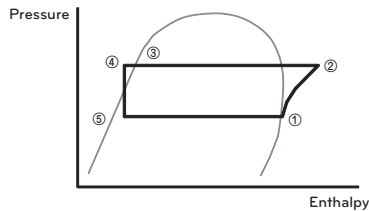

Lubrication system

Oil is efficiently separated inside the scroll compressor and even when the cycle operates, most of the oil remains inside the scroll compressor. Only part of the oil will be mixed with the refrigerant to be circulated within the cycle.

Partial load operation

Each cooling cycle operates independently and 1 cooling cycle is composed of 2 inverter compressor as shown below. 2 Inverter compressors increase the RPM after starting to operate to gradually increase the cooling capacity.

The user can operate the product smoothly at optimal condition by setting the cooling capacity based on the linear control of LG Chiller Controller and the product has efficient partial load performance at any load.

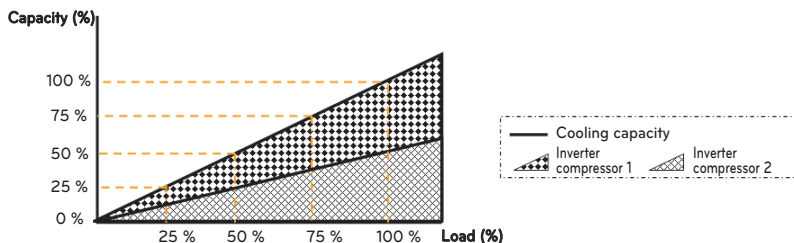

Cycle configuration and sensor location

This chiller model is configured as shown below.

1 UNIT

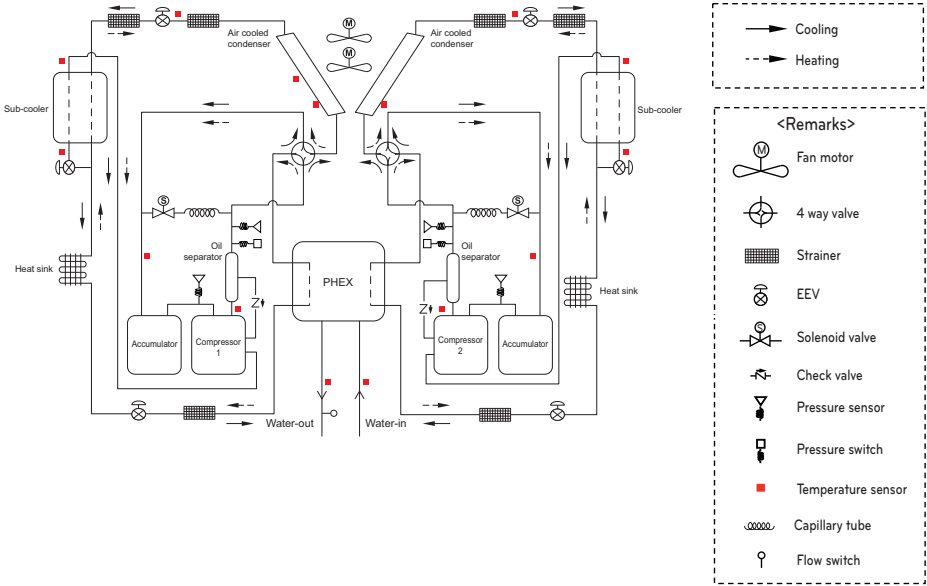

2 UNIT

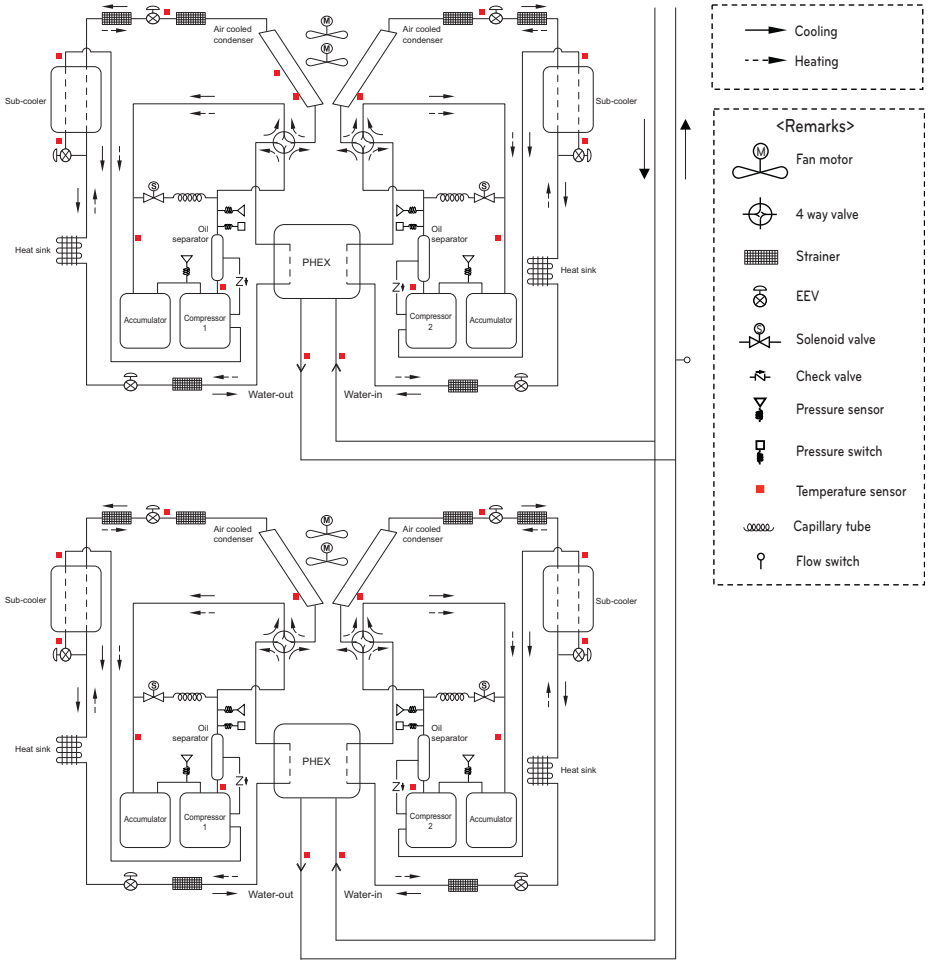

3 UNIT

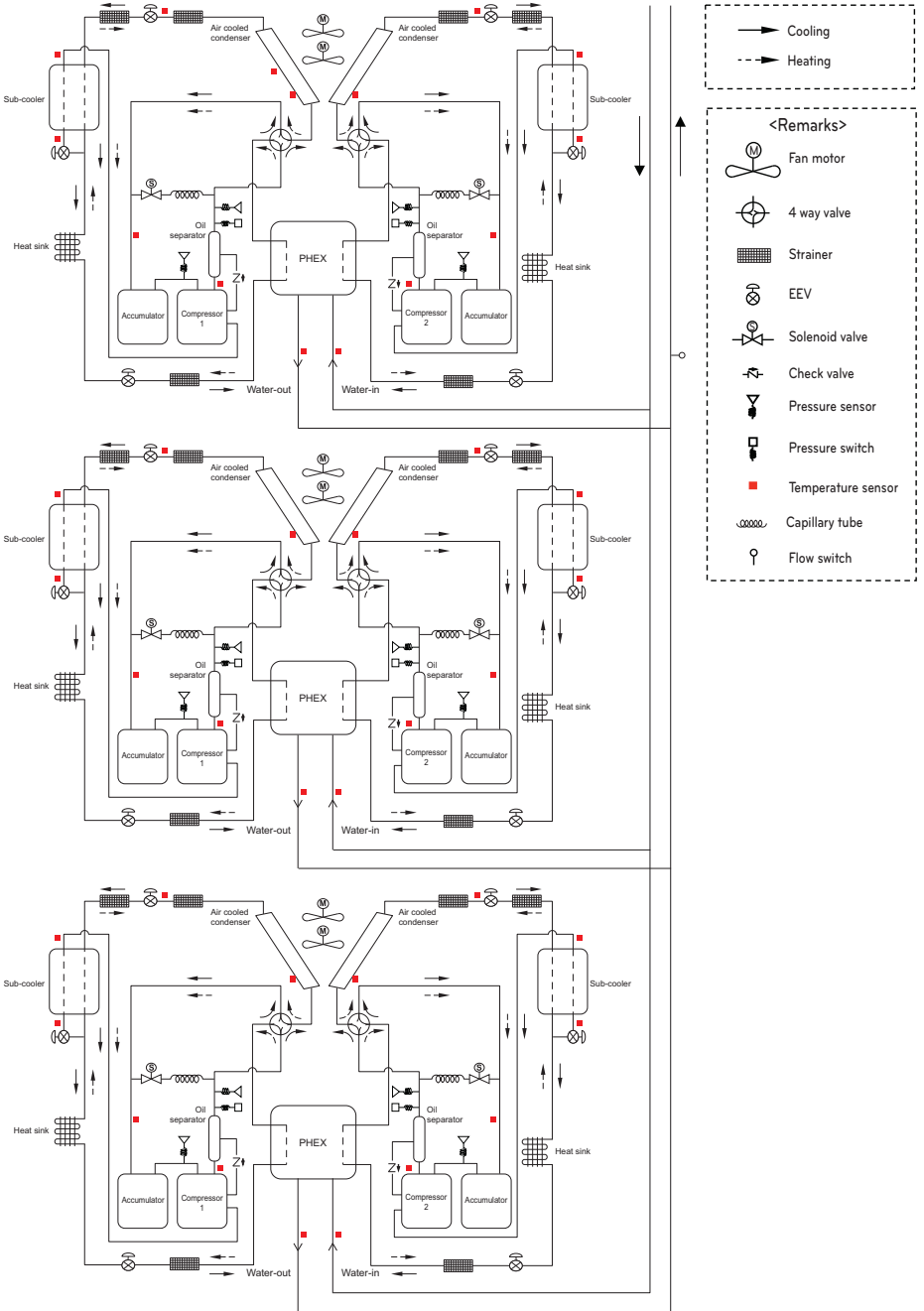

List of safety device and setting

No.	Safety device	Setting	Function
1	High pressure switch	4.2 MPa	Stops operation of the module when the pressure is above the setting
2	Fuse	250 V 5 A (Main) 250 V 15 A (INV)	Disconnects current when it exceeds the normal value
3	Compressor circuit breaker	36 A	Measures and stops over-current per compressor
4	Fan motor circuit breaker	4 A	Measures and stops over-current per motor
5	Discharge temperature sensor	120 °C	Stops compressor in stages
6	High pressure sensor	3.71 MPa	Starts protective operation control to reduce the cycle pressure
7	Low pressure sensor	0.27 MPa	Starts protective operation control to raise the cycle pressure
8	Water pipe temperature sensor	Off : 3 °C	Prevent evaporator from freezing
9	Reverse phase detector	-	Compares the current of each phase and stops when it is in reverse phase
10	Liquid compressor prevention	-	Discharge over-heating level goes up to prevent liquid compression
11	Compressor ratio limit	9	Compressor frequency is reduced when operating at high compression ratio to prevent the internal parts within the compressor from being damaged

Operation range and limit

The following table shows the operation range of the product. Do not operate the product exceeding the following operation range.

H/P

Operation range	Voltage		323 V ~ 477 V
	Cold water inlet temperature		7 °C ~ 28 °C
	Cold water outlet temperature		4 °C ~ 25 °C
	Heat water inlet temperature		25 °C ~ 57 °C
	Heat water outlet temperature		30 °C ~ 60 °C
	Outdoor temperature	Cooling	-15 °C ~ 52 °C
Heating		-30 °C ~ 35 °C	

(1) Product performance range at rated condition is 20-100 %.

- Cooling rate condition: Outdoor temperature 35 °C, Water inlet temp. 12 °C. Water Outlet temp. 7 °C
- Heating rate condition: Outdoor temperature 7 °C, Water inlet temp. 40 °C. Water Outlet temp. 45 °C

Minimum flow rate

The following table shows the minimum flow rate of the product. Do not operate the product below the minimum flow rate.

Capacity [kW]		Min. flow-rate [LPM] (Recommend)	
		Cooling	Heating
1 Unit	17RT 20RT 23RT	73	80
2 Unit	33RT 40RT 45RT	146	160
3 Unit	50RT 60RT 67RT	219	240

※ Operating below the minimum flow rate may result in product damage.

Low-temperature cooling operation

Depending on the cooling type setting, low-temperature operation is possible and the water outlet temperature range is extended. (4~25 °C → -10~25 °C)

When operating in a low temperature type (water outlet temperature : less than 4 °C), you must inject antifreeze and manage the concentration of the antifreeze at a freezing temperature of -15 °C or less.

- ※ Antifreeze concentration standard :
- Ethylene glycol : More than 30%
 - Propylene glycol : More than 35%

Operation range	Cold water inlet temperature	-7 °C ~ 28 °C
	Cold water outlet temperature	-10 °C ~ 25 °C

Operation range of heating mode

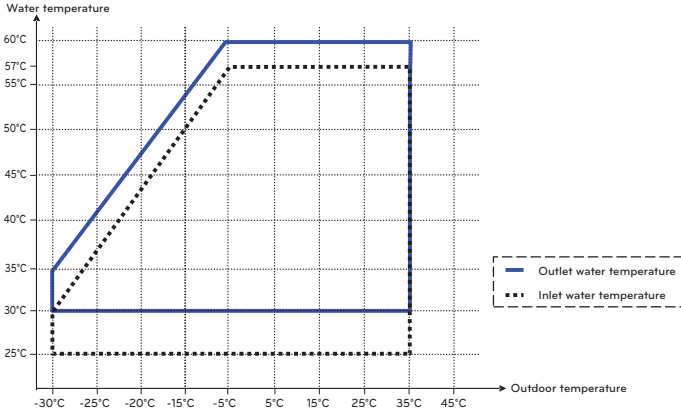

Operation range of cooling mode

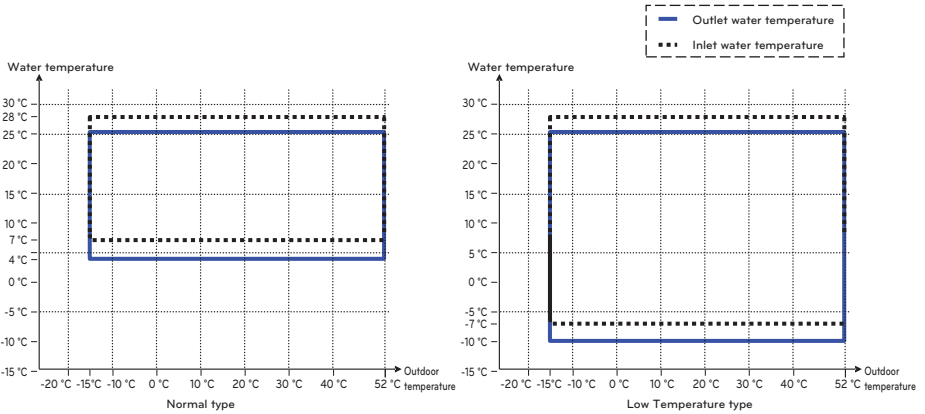

CAUTION

When running cooling operation with outdoor temperature is less than -10 °C, depending on inlet temperature, the product does not operate normally, or can take a long time for running. In this case, Please running operation After raising the inlet temperature by circulating load water. Please add antifreeze when operating at ambient temperature less than 5 °C. (There is a risk of freeze.)

CONTROL

Control panel configuration

Sub control box

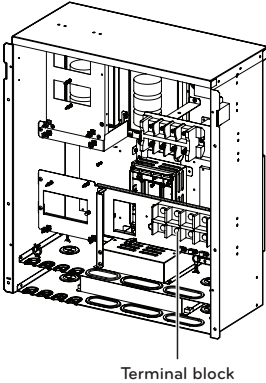

Main control box

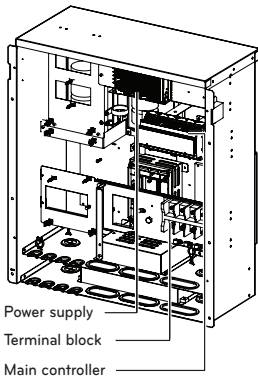

Front door Front view

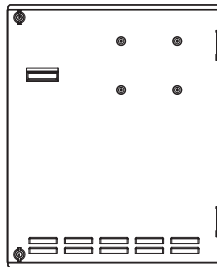

Front door Rear view

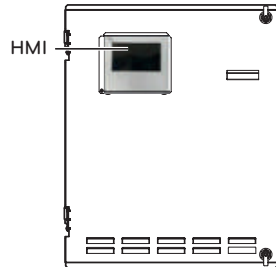

- **HMI (Human machine interface)**

This is for basic product setting and command, and shows the information of product and each cycle.

- **Main controller**

This controls the input/output port and the communication with each cycle.

- **Power supply**

This supplies the power to the HMI.

- **Terminal block**

This is the terminal block that receives the main power externally.

Chiller controller rotary, DIP switch setting

Switch location

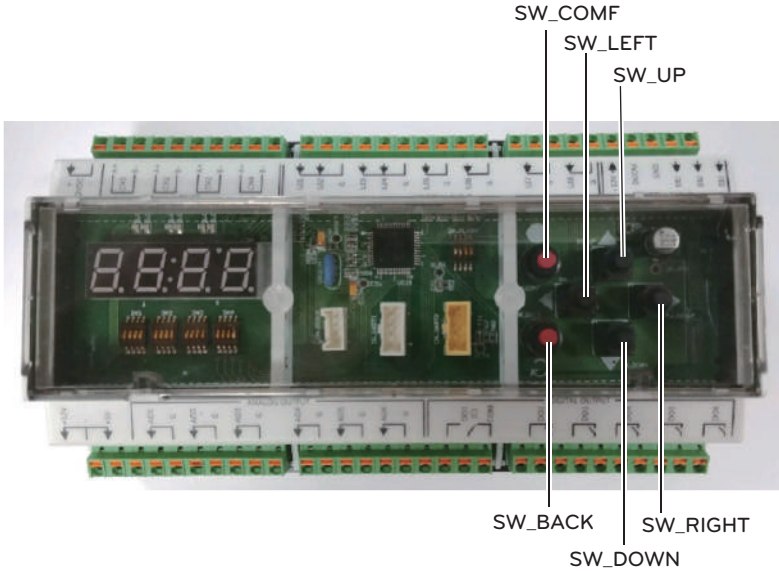

Name	Description
SW_RIGHT	Changes the setting.
SW_UP	Moves the screen.
SW_LEFT	Changes the setting.
SW_DOWN	Moves the screen.
SW_COMF	Sets the selected function.
SW_BACK	Moves to the previous step.

Chiller Controller includes the buttons described above so that the following functions are available for setting without HMI.

Option Setting

Press SW_COMF Button to move to O Level Setting Screen.



<Screen>

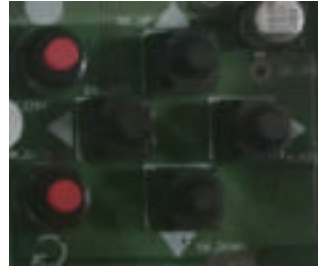

<Button>

Press Up or Down (▲▼) Button to go to a desired function.

If the desired function shows, press SW_COMF Button.

Then, the Screen moves to 1 Level Setting.

Press Left or Right (◀▶) Buttons to go to a desired function. And Press SW_COMF Button to set the function.

To go to the previous, press SW_BACK Button.

	Description	Screen Displays(0 Level)				Screen Displays(1 Level)			
1	Start/Stop	O	P	E	R		R	U	N
						S	T	O	P
2	Cooling/Heating	C	Y	C	L	H	E	A	T
						C	O	O	L
3	Cooling setpoint temperature	C	-	T	E				7
4	Heating setpoint temperature	H	-	T	E			4	5
5	Load outflow Temperature								
6	Control Mode	S	Y	S	1		L	O	C
						D	I	S	T
						S	C	H	E
7	Remote Mode	S	Y	S	2	C	O	N	T
							B	U	S
8	Central Control Address	A	D	D	R				1
9	Maximum Operation Frequency	H	I	-	R		1	1	0
10	Capacity of product	H	P	4	0				
		C	O	4	0				
11	Version			1	0				
		S	V	1	0				

Description	Screen Display (1 Level)	Detail Description
Start/Stop	RUN /STOP	Set RUN to operate the product and STOP to stop the operation.
Cooling/Heating	HEAT/COOL	Sets the product's Cooling/Heating Operation Mode. COOL selects Cooling Mode and HEAT selects Heating Mode.
Cooling setpoint temperature	7	Sets Cooling Target Temperature. (4 ~ 25)
Heating setpoint temperature	45	Sets Heating Target Temperature. (30 ~ 60)
Load outflow water Temperature	-	Shows the temperature value of Load outflow water. (Specified in 0 Level)
Control Mode	LOC/DIST/SCHE	Set's the product's Control Mode. In LOC, the product control is available with HMI and Chiller Controller. DIST refers Remote Control Mode. In SCHE, the product is controlled following the schedule set at HMI.
Remote Mode	CONT/BUS	Sets how to set in Remote Mode. CONT enables the product's operation mode by simple switch contacts. BUS enables the control on the entire product through communication from other communication devices.
Central Control Address	1	The product address can be set for communication with other communication devices. The address can be set by selecting values from 1-247.
Maximum Operation Frequency	110	Sets the Maximum Operation Frequency. (70 Hz~120 Hz)
Capacity of product	-	Shows the current Capacity of product. (Specifies in 0 Level)
Version	-	Shows the program information of Chiller Controller installed in the current product as Version. Version information is subjected to change for improvement of the product performance or the quality improvement. (Specifies in 0 Level)

Chiller address setting

Address setting of product should be set from HMI and Main Controller and if 2 addresses doesn't match each other, HMI communication error will occur.

• Main Controller address setting

Press down direction and right direction button (▼▶) at the same time.

When FN01 appears, press SW_CONF button.

Select desired address using left and right button (◀▶) and address will be set if press SW_CONF button.

If you don't want, please press SW_CONF button.

	Description	Screen Displays(0 Lever)				Screen Displays(1 Lever)			
1	Chiller Address	F	N	0	2				1



CAUTION

- If Main Controller address doesn't match HMI address, Error will occur. (please refer to control>freezer interlocking control about HMI address setting)

Logging in to HMI

This chapter will explain about the composition of each screen in HMI, detail functions, and operation methods. When power is applied to HMI, HMI automatically operates. When HMI starts, Home screen appears.

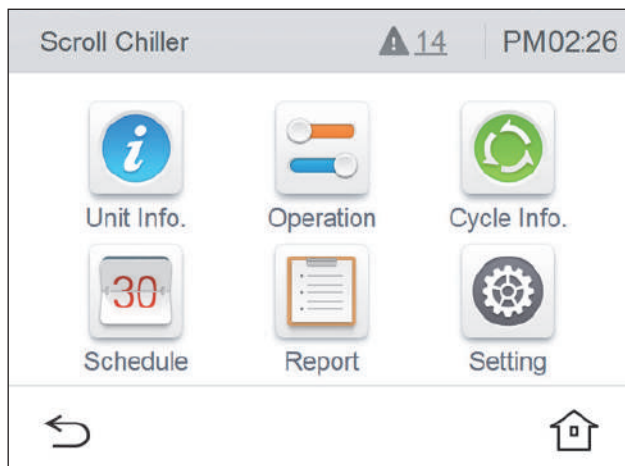

! CAUTION

When HMI is installed indoors, the guaranteed communication distance is 500 m.

- Guaranteed communication distance of HMI: 500 m

(But, when connected indoor, the end resistance (100-200 Ω) must be installed at the terminal connected to HMI for smooth communication. In this case, if the installation location of the Unit is different from that of HMI, the maximum permitted connection distance of the communication cable between the two locations is displayed.)

Introduction to HMI menu

This chapter describes the HMI menus to know to operate the product and how the screen is configured.

HMI main screen configuration

After logging in to HMI, the system view screen that shows the common information of the product is displayed as shown below.

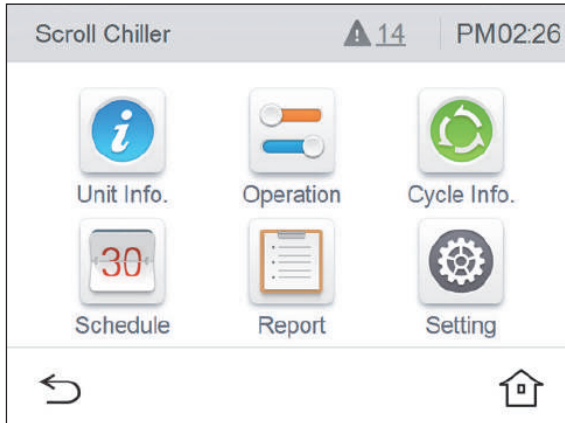

Icon	Description
	You can see the load water temperature, pump/flow amount status, and system information.
	It sets the Start/Stop, Set Temperature, Operation Mode (Only for Heatpump Model), control mode, max. operation frequency, and demand control ratio are set.
	It checks the individual cycle's operation information.
	It checks the set schedule.
	It checks the occurred error history.
	It sets the installer setting, screen setting, and system setting.
	It returns to the previous menu.
	Home screen appears.

View chiller information

Chiller information is composed of the load water temperature, pump/flow amount status, and system information.

- Load water temperature screen

Unit Info.	
Load Water Temp.	
E.W.T	0.0°C
L.W.T	0.0°C

Icon	Description
E.W.T	It shows the common load entering water temperature value.
L.W.T	It shows the common load leaving water temperature value.

• Pump/flow amount status screen

Unit Info.	
Pump / Flow Status	Load Water
Pump Output	OFF
Pump Interlock	OFF
Flow Switch	OFF
Capacity	20RT

Icon	Description
Pump Output	<p>If it is in operation, it always maintains ON, and when the product operation is stopped, the freeze and burst mode is applied, and the freeze and burst prevention mode operates as follows.</p> <p>According to the outdoor air temperature condition, the load water pump repeats operation ON and OFF.</p> <ul style="list-style-type: none"> - Water temperature < Freezing Temperature +1 °C → always "ON" - Freezing Temperature +1 °C ≤ Water temperature ≤ Freezing Temperature +3 °C → 2 min. operation and 18 min. stop - Water temperature > Freezing Temperature +3 °C → operation "OFF" <p>The freeze and burst prevention mode is possible when the pump is connected, and to interface with the pump, Pump Output connect shall be connected, and to check whether the pump operates, Pump Interlock connector shall be connected. (For the connector connection method, refer to the connection diagram.)</p>
Pump Interlock	<p>It receives the status of the load water pump output through the external signal contact point of the pump. (When the product is in operation, the pump output shall maintain "ON" state, and otherwise, alarm will occur.)</p>
Flow Switch	<p>It shows the current load water's flow amount switch status value. (When the product is in operation, the pump output shall maintain "ON" state, and otherwise, alarm will occur.)</p>
Capacity	<p>It shows the capacity of the device.</p>

- System information screen

Unit Info.	
System Information	
Setting Temp.	12.5°C
Outdoor Temp.	10.0°C
Operation Current	10.0A
Starting Delay	10sec

Unit Info.	
System Information	
Flow Rate	1.0GPM

Icon	Description
Setting Temp.	It shows the set temperature for the current operation mode.
Outdoor Temp.	It shows the current outdoor air temperature value.
Operation Current	It shows the operation compressor's overall operation current value.
Starting Delay	It shows the time of the standby state before starting the product.
Flow Rate	It shows the flow rate of system

Chiller control

Chiller control sets the Start/Stop, Set Temperature, Operation Mode (Only for Heatpump Model), Control Mode, and Max. Operating Frequency.

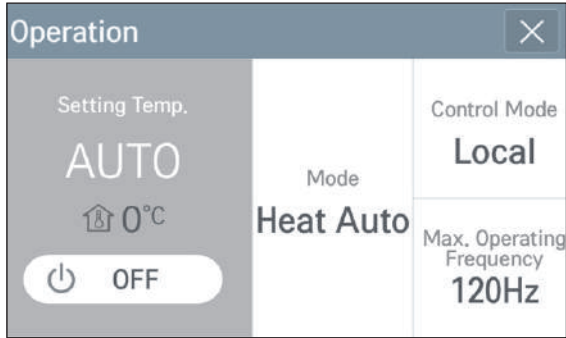

Icon	Description
 ON	It selects the start and stop signal command of the product.
Setting Temp.	It sets the target temperature value for the current operation mode. (Cooling : 4.0 ~ 25.0 °C, heating : 30.0 ~ 60.0 °C)
Mode Heat Auto	It sets the Cooling/Heating/Cooling Auto/Heating Auto operation mode.
Control Mode Local	It selects the control mode of the signal command method for the product control.
Max. Operating Frequency	Max. Operating Frequency is the feature to save the energy by limiting the operation capacity up to the frequency set by the user. (Setting Range : 70 Hz ~ 120 Hz) The standard set value for the Max. Operating Frequency is 120 Hz.
Demand-Control Ratio	The setting unit for the Max. Operating Frequency is 10 Hz. Demand control is a function that saves energy by limiting the operating capacity of the user. (0: unused, 50~100%)

- **ON/OFF**

When you touch the ON button, a popup window to select ON/OFF is displayed.

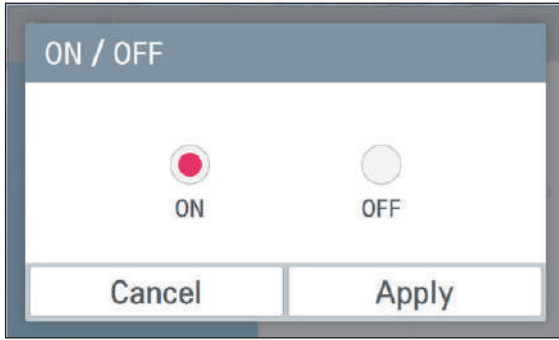

- **Setting temperature**

If you touch the area where the chiller control's set temperature is displayed, a popup window to input the setting temperature is displayed.

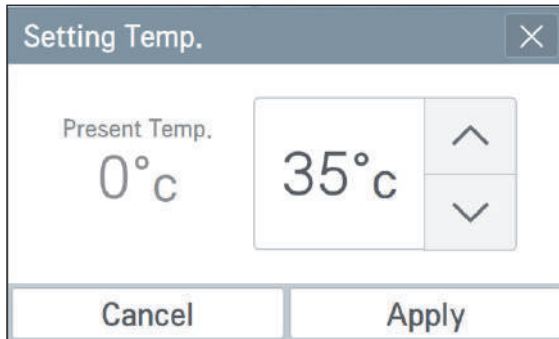

In the temperature setting popup window, you can change the temperature with up/down arrow input, and if you touch the temperature setting display area, you can input the setting temperature input with numeric keyboard.

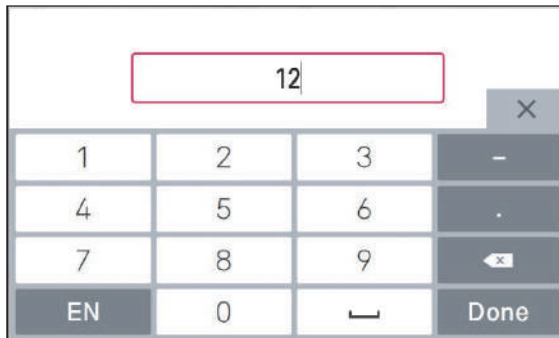

After changing the temperature setting, if you press Apply, the set value is reflected, and if you press Cancel, the previous setting is maintained.

- **Operation mode**

If you touch the chiller control's operation mode area, a popup window to set the operation mode is displayed.

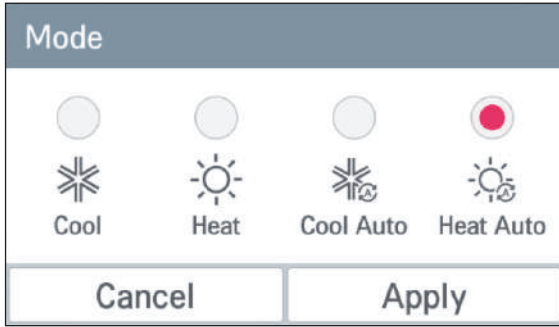

After changing the operation mode, if you press Apply, the set value is reflected, and if you press Cancel, the previous setting is maintained.

NOTE



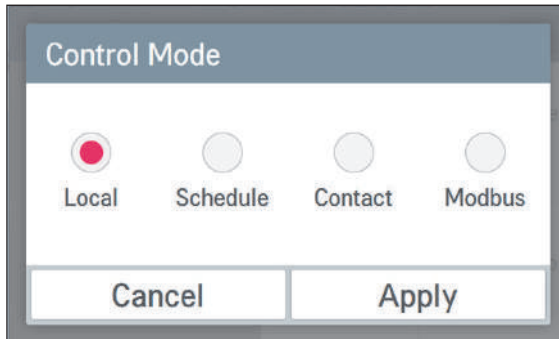

In automatic cooling/automatic heating operation mode, the set temperature is displayed as "Auto" when it operates automatically according to the outside temperature. and the set temperature is not controlled.

- **Control mode**

If you touch the chiller control's control mode area, a popup window to set the control mode is displayed.



After selecting the desired control mode, if you press Apply, the selected control mode is applied, and if you press Cancel, the previous setting is maintained.

Icon	Description
 Local	Manual control mode through HMI
 Schedule	If the schedule mode is set, manual and remote control are not possible, and only the start/stop by the schedule is possible.
 Contact	ON/OFF is only possible by the chiller controller's "Remote Start" signal.
 Modbus	ON/OFF is only possible by the external MODBUS communication.



CAUTION

If the product enters the modbus remote mode, all the information can only be monitored via HMI, and the actual operation of starting/stopping or changing the set temperature can only be done through the external controller.

To make changes to control from HMI, change the control mode to "Local".

**CAUTION**

CH10009 remote communication error will occur when the communication is disconnected between the two controllers. When the communication is recovered, it will automatically resume. If the remote modbus connection is not used, reset the power of the main PCB of the unit to cancel the alarm.

The protocol details provided for modbus interlock of external device are as follows.

- Physical Layer : RS-485 Serial Line
- Mode : MODBUS RTU Mode
- Baud Rate : 9 600
- Parity : None Parity
- 1 Stop Bit
- Applied Function Code

Function Code	Sub Function	Function Name	Start Address form Master Device
0x01	None	Read Coil Register	Address-1
0x02	None	Read Discrete Input	Register Address-10001
0x03	None	Read Holding	Register Address-40001
0x04	None	Read Input	Register Address-30001
0x05	None	Write Single Coil	Register Address-1
0x06	None	Write Single Holding	Register Address-40001
0xF1~FF	Reserved for Exception Code		

Refer to the modbus protocol in the Appendix for the protocols provided.

Select whether to use the max. operation frequency or demand control. The default setting is the max. operating frequency.

Device	Setting1	
Edit Unit Address	Cooling&Defrost Type Normal	System Password ****
Temp offset correction	Thermo On offset correction	Capacity Control Max Operating Frequency

In the installer mode, if you press the capacity control setting for more than 5 seconds and enter the password, a pop-up window for setting the capacity control type appears. Select the wanted capacity control and click the Apply button. If you press the cancel, it keeps the previous settings.

- **Max. Operating Frequency**

If you touch the Max. Operating Frequency area, a popup window to input the Max. Operating Frequency is displayed.

Capacity Control
✕

Max. Operating
Frequency

Demand Control
Ratio

Cancel

Apply

The Max. Operating Frequency can be adjusted by pressing Up/Down arrows in the popup window for the Max. Operating Frequency.

- **Demand control ratio**

If you touch the demand control ratio, a pop-up window appears where you can enter the operation rate.





Demand Control ratio can be adjusted by inputting up/down arrows in the demand control ratio pop-up window.

Cycle information screen composition

To enter the cycle information screen, press the cycle information button in Home screen.

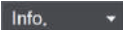
Cycle #1	Info.	
Cycle Info._Chiller 1	A	B
Hot-gas Valve	OFF	ON
Sump Heater	OFF	OFF

Icon	Description
	It shows the currently selected cycle.
	You can select the cycle information and the cycle temperature.
	Show the status of hot gas valve.
	Show the status of sump heater.

Cycle #1	Info.	
Cycle Info__Chiller 1	A	B
Inverter Comp.	0Hz	0Hz
EEV status	0pls	0pls
High Pressure	0kPa	0kPa
Low Pressure	0kPa	0kPa

Icon	Description
Inverter Comp.	It shows the inverter compressor's operation frequency value.
EEV status	It shows the current EEV pulse signal value.
High Pressure	It shows the current high pressure value.
Low Pressure	It shows the current low pressure value.

Cycle #1	Info.	
Cycle Info__Chiller 1	A	B
Operating Current	0.0A	0.0A
Operating Hours	2hr	3hr

Icon	Description
Operating Current	Show the operation current value of operation compressor.
Operating Hours	Show operation time.

- Cycle temperature

Cycle #1	Temp.		<	>
Cycle Temp._Chiller 1	A	B		
Load W	0.1°C	0°C		^
Load Source.	0.1°C	0.0°C		1/2
Sat. Condensing	0°C	0.0°C		
Sat. Evaporating	0.0°C	0.0°C		v

Icon	Description
Load W	Show individual outlet temperature value of the cycle.
Load Source.	Show individual inlet temperature value of the cycle.
Sat. Condensing	Show condensation temperature value of the cycle.
Sat. Evaporating	Show Evaporation temperature value of the cycle.

Cycle #1		Temp.		<	>
Cycle Temp._Chiller 1	A	B			
Discharge	23,5°C	23,5°C	^		
Suction	23,5°C	23,5°C	2/2		
Hex Temp	23,5°C	23,5°C			
Liquid Temp	23,5°C	23,5°C	v		

Icon	Description
Discharge	Show compressor discharge temperature value of the cycle.
Suction	Show compressor discharge temperature value of the cycle.
Hex Temp	Show HEX temperature value of the cycle.
Liquid Temp	Show liquid line temperature value of the cycle.

Introduction to schedule menu

This chapter describes the schedule menu and screen composition that you need to know to operate the schedule of the product.

View schedule screen

In Home screen, if you press the schedule icon, the schedule screen appears.

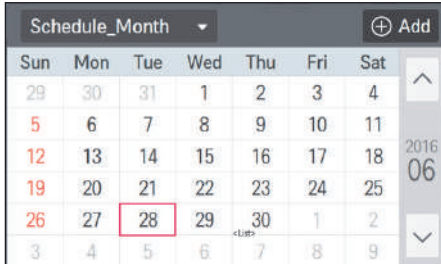

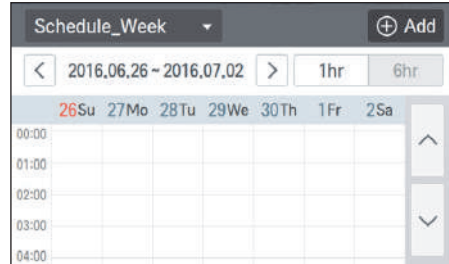

<Month>

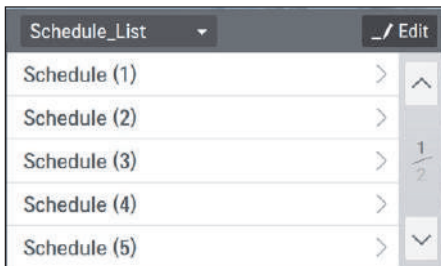

<Week>

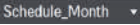
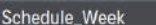

<List>

Icon	Description
	You can check the monthly set schedule at a glance.
	You can check the start time of the schedule and the set operation mode.
	You can check the set schedule in a list.

- Add schedule

1. In the schedule viewing screen, press Schedule_Month button at the top right side.

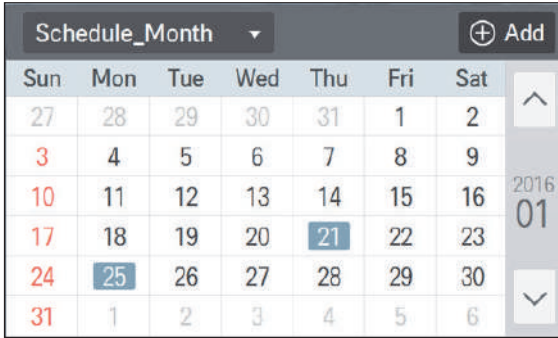

2. As follows, when Add screen appears, input the basic schedule information.

Add	
Next ▶ ×	
Phase1. Input basic schedule information.	
Name (50) Schedule (8)	Period 2016.06.28 ~ 2066.06.28
Time AM 12:00	Repeat Everyday

- ① When you press the name area, a popup window to input the schedule name is displayed. Input the name to use, and press Apply button. If Cancel button is pressed, the previous setting is maintained.

Name Setting(50 Letter)	
Schedule (8)	
Cancel	Apply

- ② When you press the date area, a popup window to set the date is displayed. Set the start date and end date to use the schedule operation, and press Apply button. If Cancel button is pressed, the previous setting is maintained.

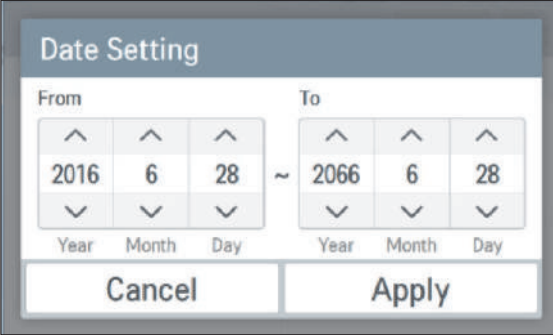

Date Setting

From To

2016	6	28	~	2066	6	28
Year	Month	Day		Year	Month	Day

Cancel Apply

- ③ When you press the time area, a popup window to set the time is displayed. Set the time to use the schedule operation, and press Apply button. If Cancel button is pressed, the previous setting is maintained.

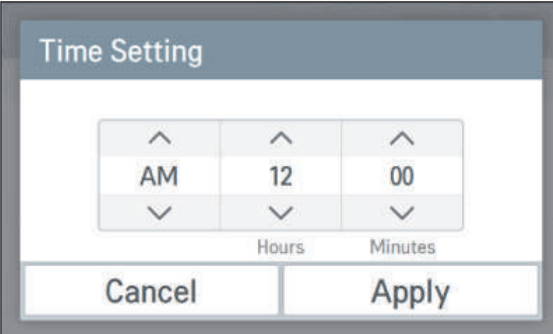

Time Setting

AM	12	00
	Hours	Minutes

Cancel Apply

- ④ When you press the day of week selection area, a popup window to select day of week is displayed. Select the day of week to use the schedule operation, and press Apply button. If Cancel button is pressed, the previous setting is maintained.

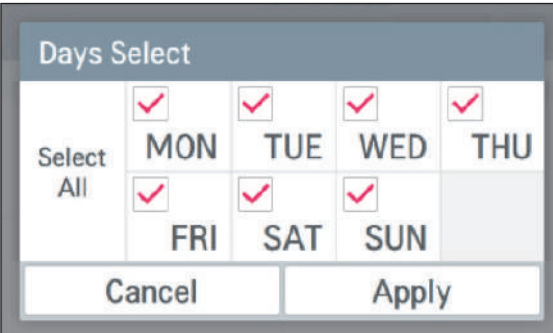

Days Select

	<input checked="" type="checkbox"/>	<input checked="" type="checkbox"/>	<input checked="" type="checkbox"/>	<input checked="" type="checkbox"/>
	MON	TUE	WED	THU
Select All	<input checked="" type="checkbox"/>	<input checked="" type="checkbox"/>	<input checked="" type="checkbox"/>	
	FRI	SAT	SUN	

Cancel Apply

3. After the input of the basic information, if you press **Next** button, a screen to set the detail information is displayed.

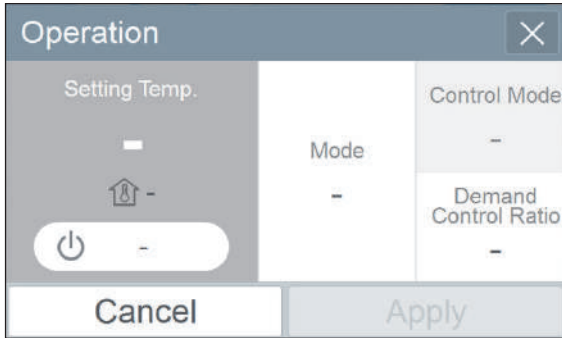

- ① When you press the mode area, a popup window to select the mode is displayed. Select the operation mode to use the schedule operation, and press Apply button. If Cancel is pressed, the previous setting is maintained.

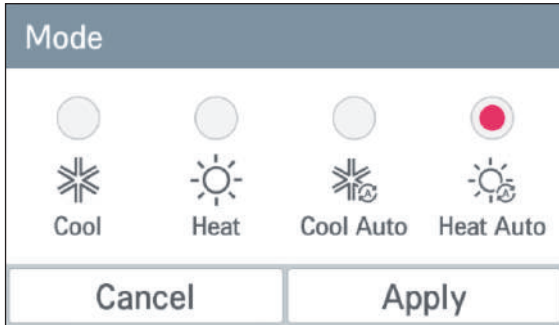

NOTE

In automatic cooling/automatic heating operation mode, the set temperature is displayed as "Auto" when it operates automatically according to the outside temperature. and the set temperature is not controlled.

- ② When you press the area where the set temperature is displayed, a popup window to input the temperature setting is displayed. Set the temperature to use, and press Apply button. If Cancel is pressed, the previous setting is maintained.

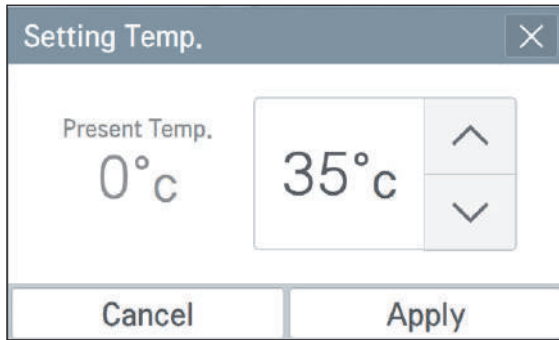

- ③ When you press the ON/OFF button, a popup window to select ON/OFF is displayed. Decide whether to ON or OFF the schedule operation to use, press the button to use, and press Apply button. If Cancel is pressed, the previous setting is maintained.

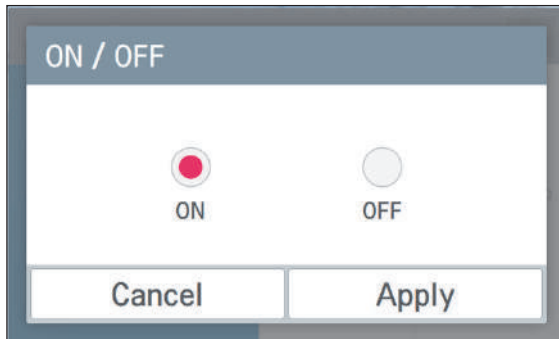

- ④ When the Max. Operating Frequency are is touched, the popup window to enter the Max. Operating Frequency opens.
After selecting a value to set, press Apply button. If cancel is pressed, the previous setting is remained.

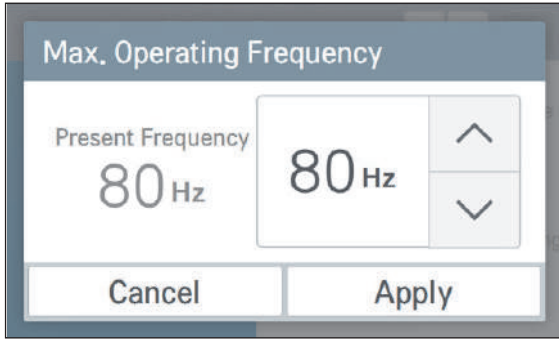

4. After the input of all detail information, when you press Apply button of the chiller control, the schedule addition is completed.
If Cancel is pressed, the previous setting is maintained.
It only works when control mode is changed from 'Local' to 'Schedule'.

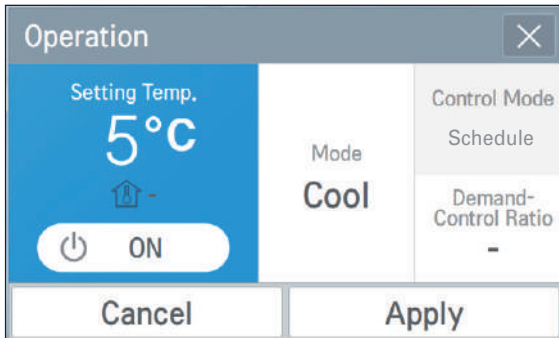

- Edit schedule

1. In View schedule _ List screen, select the schedule to edit.



2. When the popup window of the selected schedule is displayed, press the button to work.

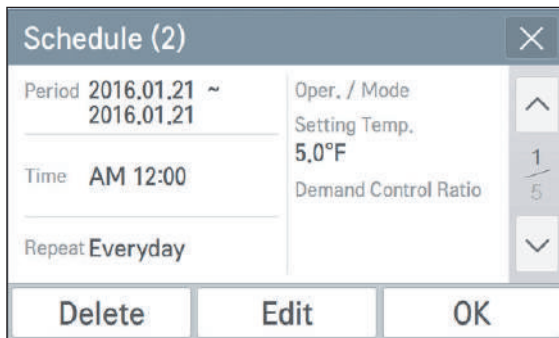

Icon	Description
	Popup window saying "Do you want to delete the selected schedule?" is displayed, and when you press Apply button, it is deleted from the list.
	A popup window to edit is displayed, and set with the same method as the schedule addition.
	It maintains the current setting, and the popup window disappears.

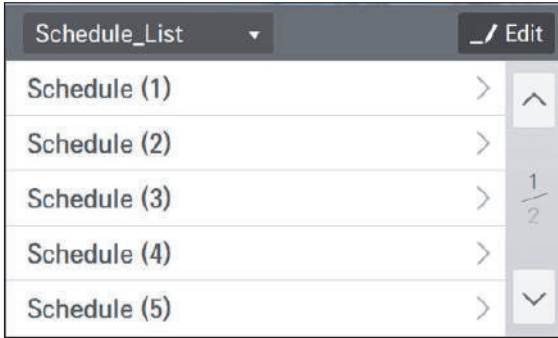

- Schedule list edit

1. In View schedule _ List screen, press  button at the top right side.

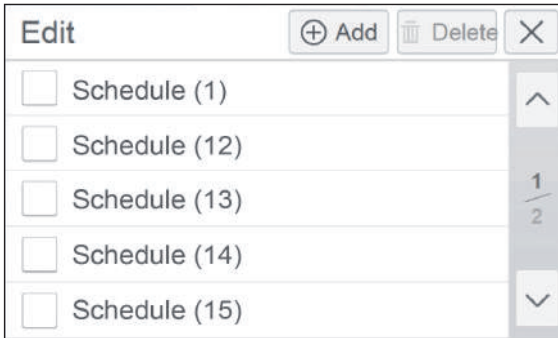

2. When the screen to edit the list appears, carry out the schedule addition and list deletion work.



Icon	Description
	When Add button is pressed, it moves to the schedule addition screen.
	When you select a list to delete, Delete button is activated, and when you press Delete button, the selected list is deleted.

Introduction to record menu

This chapter describes how to check the record of the events that triggers the alarm.

• Error screen composition

The occurred error history is stored in the order of the occurred time, and according to the selection, you can check for day, week, and month.

Date	Time	Address	Code	Detail Info.
2015-09-21	04:19:07	1	14	
2015-09-16	06:02:13	1	3	
2015-09-03	00:47:19	1	14	
2015-09-03	00:47:19	1	1	

• View detail information

When you select a history to view in detail, detail information popup window is displayed. It shows the error occurrence date, time, address, code, and the information of the error code. When you press Confirm, the popup window disappears.

Date	2015-09-21	Addr.	1
Time	04:19:07	Code	14
Info.			

OK

- **Delete history**

When you press **Clear** button at the top right side of Error screen, a popup window to input password is displayed.

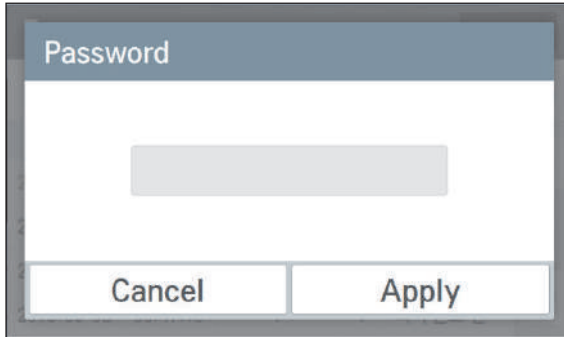

A dialog box titled "Password" with a white background and a grey border. It contains a single text input field in the center. At the bottom, there are two buttons: "Cancel" on the left and "Apply" on the right.

Input the password, and when you press Apply button, all error histories will be deleted.

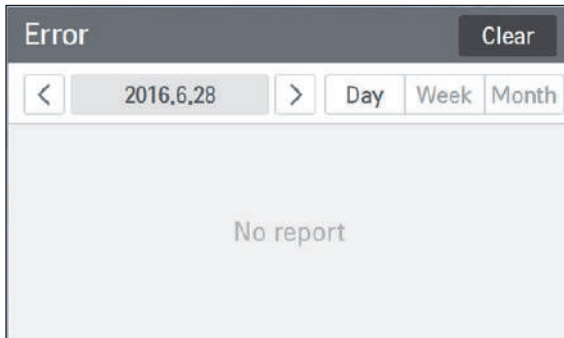

An "Error" report screen with a dark grey header. The header contains the word "Error" on the left and a "Clear" button on the right. Below the header is a navigation bar with a left arrow, a date field showing "2016,6,28", a right arrow, and three filter buttons: "Day", "Week", and "Month". The main content area is light grey and displays the text "No report" in the center.

※ The clear function is for the service, and the password will not be provided to the customers.

View setting menu

This chapter describes the setting menu's screen and the setting method required for the operation of the product.

Setting screen composition

In Home screen, if you press Setting button, after password input, it enters Setting screen, and the following screen appears. (Initial password: digital21)

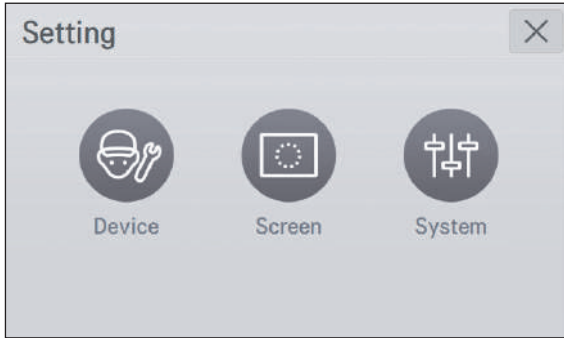

Device

In the setting screen, when you press the device icon, device screen appears.

Device	Setting1	
Edit Unit Address	Cooling&Defrost Type Normal	System Password ****
Temp offset correction	Thermo On offset correction	Capacity Control Max Operating Frequency

Icon	Description
Edit Unit Address	It sets chiller address and count of chiller units. Initial chiller address and count of chillers is 1. For automatic control (or ACP), MODBUS communication, and HMI interface, if chiller main PCB address is changed, HMI chiller address setting value shall be set as the same as main controller.
Cooling & Defrost Type	Either normal type or low temperature type can be set. When using the low-temperature type, the water outlet temperature range is extended and antifreeze must be injected.
System Password	It selects whether to change and use password. (Initial password : digital21)
Common water out temperature offset correction	It is a function for the service and it is restricted.
Thermo On off-set correction value	It is a function for the service and it is restricted.
Capacity control	Max. operation frequency mode / demand control ratio mode can be set.

• Edit Unit Address

In the device mode, if you press Edit Unit Address area, the Edit Unit Address window is displayed.

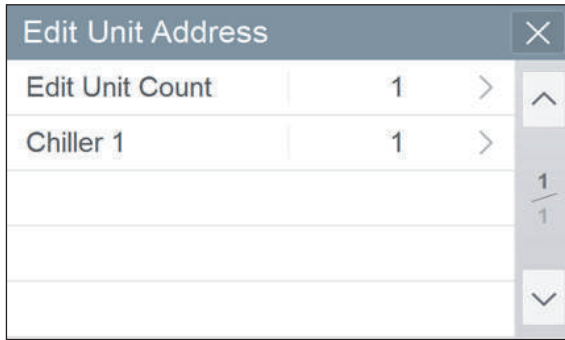

If you press Edit Unit Count area, a window to set count of chillers appears. Select from 1 to 5, Count of chillers to interface, and press Apply button. If Cancel is pressed, the previous setting is maintained.

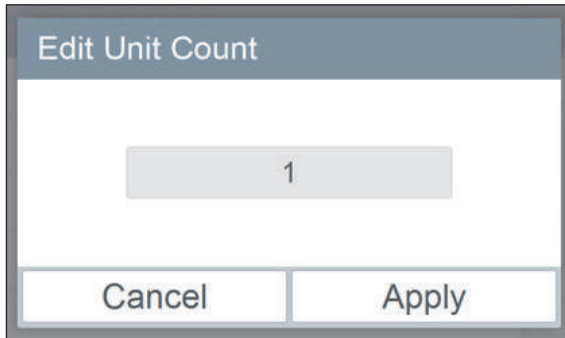

* Default value is 1, and you can set and use up to 5.

* Setting product address The product address must be in both chiller PCB of unit and HMI. If the two addresses are not the same, there will be an error in HMI communication.

! CAUTION

If you reset the address in HMI while the product is operating, it will cause a communication error and stop the product. Always reset the address after the product has stopped completely.

In Edit unit Address, if you press chiller 1 area, Edit Unit Address window appears. Input the desired address and press Apply button. If Cancel is pressed, the previous setting is maintained.

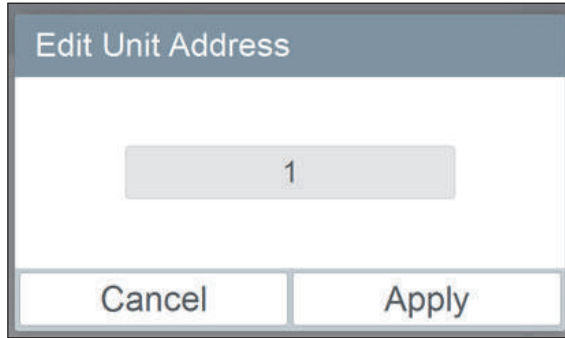

The image shows a dialog box titled "Edit Unit Address". It features a central text input field with the number "1" entered. Below the input field are two buttons: "Cancel" and "Apply".

* If you select 2 or more unit count, you need to input address for each unit.

• Cooling & Defrost Type

In setup_installer mode, press the Cooling & Defrost Type for more than 5 seconds and enter the password, a pop-up window to set the cooling type appears. After selecting the desired cooling type, click the Apply button. Press Cancel to keep the previous settings

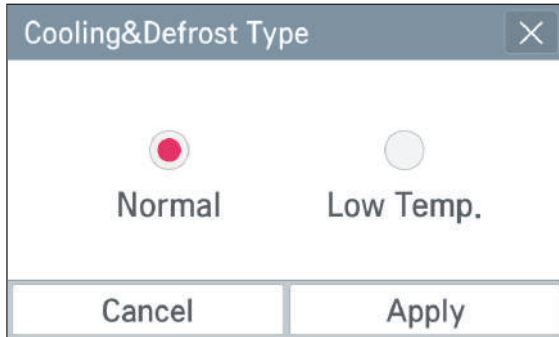

- * When changing the cooling type to the low temperature type, the concentration of antifreeze must be managed by referring to the minimum antifreeze concentration for a freezing temperature of -15 °C.
- * Depending on the type selection, the defrost driving escape water inlet temperature must be classified.
 - Normal type: Defrost is not possible when the water inlet temperature is below 15°C
 - Low Temp: Defrost is not possible when the water inlet temperature is below 6°C

! CAUTION

- When using the Low temperature type setting, if antifreeze is not added, the parts may be damaged.
- If the air intake temperature drops below the standard for each model, please defrost it. It does not work, and there is a risk of damage to the product due to accumulated icing.
- When refilling with antifreeze, add at least 30% ethylene glycol and at least 35% propylene glycol. Otherwise, the plate heat exchanger may freeze and burst.
- If the plate heat exchanger bursts, you are responsible.

- **Password setting**

In the device mode, if you press System Password area, Password window is displayed.

1. Do not use password



- ① If you press Use ON area, it is changed to Use OFF.



- ② Select Apply. If Cancel is pressed, the previous setting is maintained.

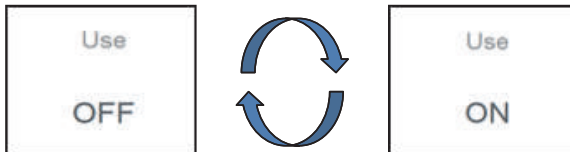

* Default is Use, and if you want to use again, you can press Use OFF, input password, and press Apply. (Initial password: digital21)

2. Password change

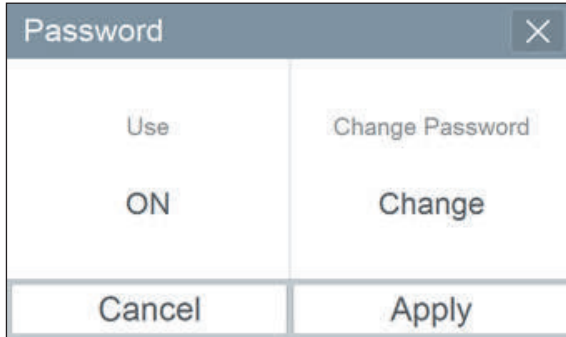

① If you press Chang Password area, Change Password window appears.

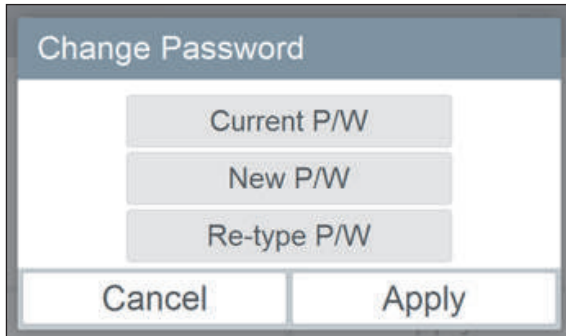

② Input Current P/W, New P/W, and Re-type P/W, and press Apply button.

* If you input wrong password for 5, it check whether to initialize the password. If you press Cancel button, password input screen appears again. For password initialization, please contact installation store or service center.

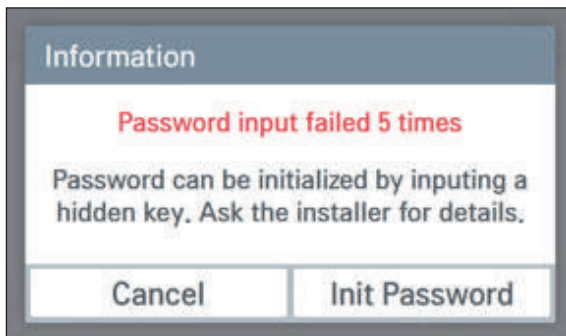

Select Setting 2 on the Setup_Installer Mode screen, and the following screen will appear.

Device		Setting2	
High Temperature	Condensing Temp (Water Spray)	Flow sensor Usage	Flow Rate Unit
HE Frozen error	Outdoor Temp (Water Spray)	Min Flow Rate	Max Flow Rate

Icon	Description
High Temperature	This function is used for on-site inspection only for models with a legal freezing capacity of 20RT or higher.
HE Frozen error	This function is used for on-site inspection only for models with a legal freezing capacity of 20RT or higher.
Condensing Temp (Water Spray)	Set the condensation temperature at which the spray function works.
Outdoor Temp (Water Spray)	Set the outdoor temperature at which the spray function works.
Flow sensor Usage	Select whether to use a flow sensor or not.
Flow Rate Unit	Set the display unit when using the flow sensor. (GPM or LPM)
Min Flow Rate	Set the minimum flow rate when using the flow sensor.
Max Flow Rate	Set the maximum flow rate when using the flow sensor.

Press the condensation temperature (spray) or the outdoor temperature (spray) icon to display the following screen.

- Range of condensation temperature settings: 40 to 60 °C
- Range of outdoor temperature settings: 20 to 60 °C

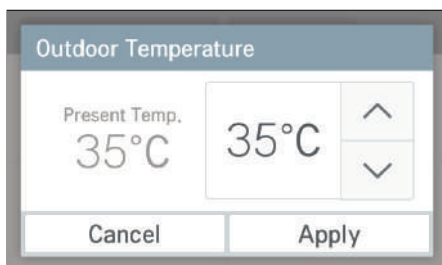
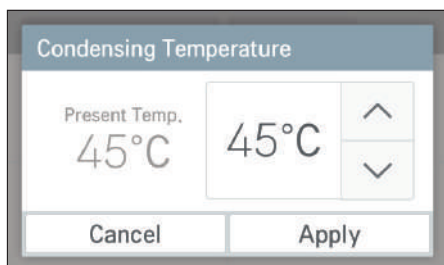

- **Flow sensor usage setting**

Press the Flow sensor Usage icon to display the following screen.

Select whether to enable or disable the flow sensor, and press Apply button.

Press Cancel to keep the previous settings

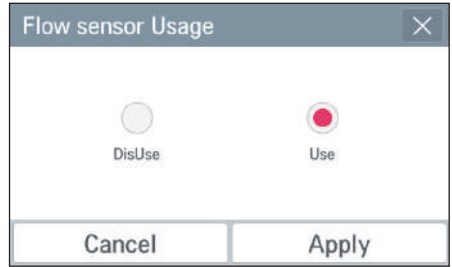
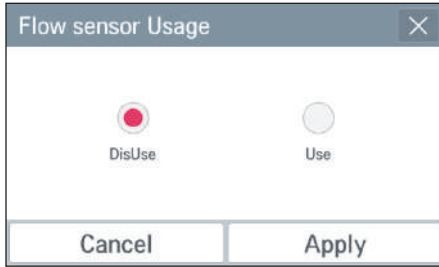

- **Flow rate unit setting**

Press the Flow Rate Unit icon to display the following screen.

After selecting the flow rate unit (GPM or LPM), click the Apply button.

Press Cancel to keep the previous settings

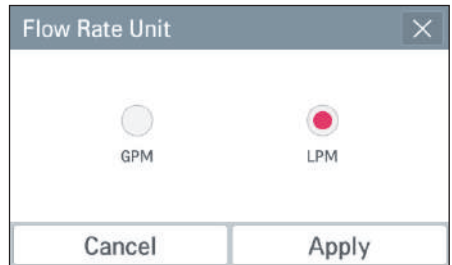
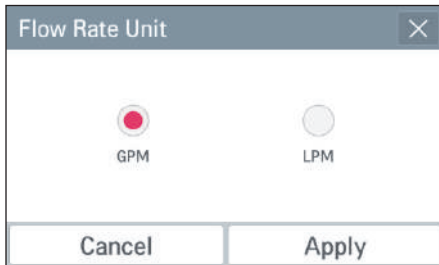

- **Min/Max flow rate setting**

Press the Min Flow Rate or Max Flow Rate icon to display the following screen.

After selecting the minimum or maximum of flow rate, click the Apply button.

Press Cancel to keep the previous settings

Initial Min/Max Flow rate is '0'

The Min flow rate must be lower than The Max flow rate, So be careful when you changing the setting. (0 ~ 0.57 m³/min or 0 ~ 0.6 m³/min)

Min Flow Rate	
Setting Value	100.0
100.0	100.0
	^
	v
Cancel	Apply



Max Flow Rate	
Setting Value	150.0
150.0	150.0
	^
	v
Cancel	Apply

*Refer to "How to connect the flow rate sensor"

Screen

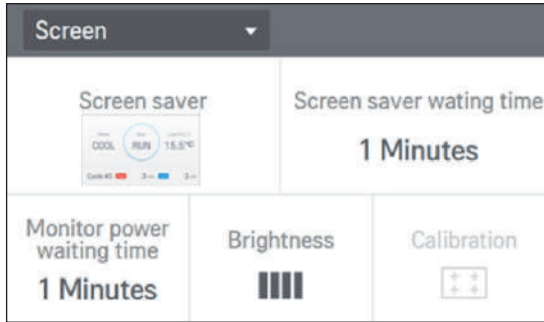
In the setting screen, when you press the screen icon, Screen appears.

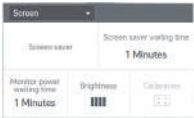

Icon	Description
	Select whether to use the screen saver.
Screen saver waiting time 1 Minutes	It sets the waiting time to display the screen saver.
Monitor power waiting time 1 Minutes	It sets the time to change to the minimum brightness of the screen when there is no touch input.
Brightness 	It adjusts the screen brightness according to the ambient illumination intensity.

- **Screen saver**

When you press the screen saver area, the screen saver window is displayed.

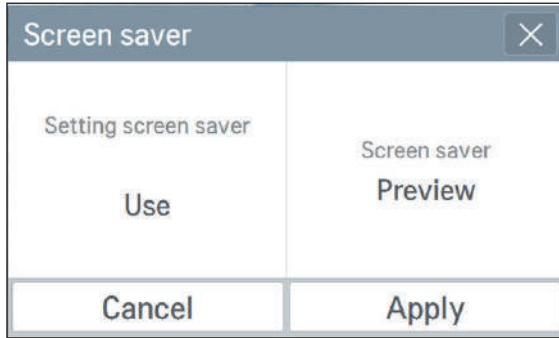

- ① Press the area indicating whether to use the screen saver. Whenever you press the area, the selected value is changed.

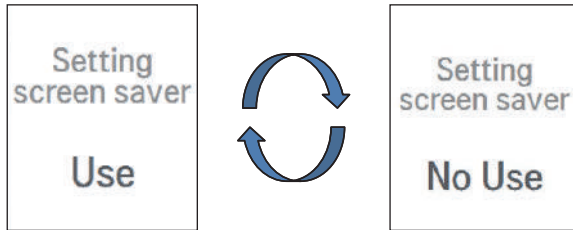

- ② When whether to use the screen saver is selected as Use, the screen saver preview is activated, and when you press the activated area, you can see the set screen saver in advance.

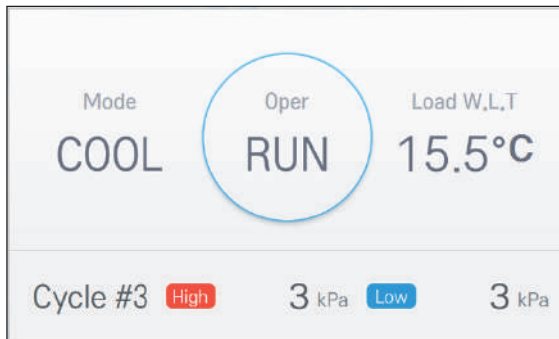

- ③ When you press Apply button of the screen saver, the selected setting is applied, and if Cancel is pressed, the previous setting is maintained.

- **Screen saver waiting time**

When you press the screen saver standby area, the screen saver standby window is displayed.

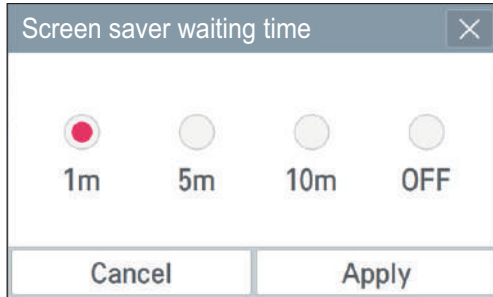

After selecting the time to apply, press Apply button. If Cancel is pressed, the previous setting is maintained.

- **Monitor power off**

When you press the screen power saving area, the screen power saving window is displayed.

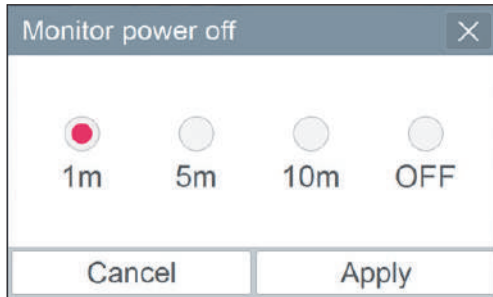

After selecting the time to apply, press Apply button. If Cancel is pressed, the previous setting is maintained.

- **Brightness**

When you press the screen brightness area, the screen brightness window is displayed.

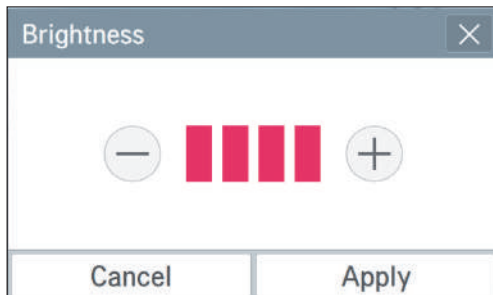

After setting the desired brightness by pressing the –and + button at the left/right, press Apply button. If Cancel is pressed, the previous setting is maintained. The screen brightness can be selected among 25 %, 50 %, 75 %, and 100 %.

System (Normal)

When you press the system icon, System screen appears. System is divided to normal and advance.

System		Normal
Date	Time	Controller name
2016.06.28	PM 07:27	Scroll Chiller
Speaker	Temperature display	Language
OFF	°F	English

Icon	Description
Date 2016.06.28	It is the base value of the date recognized by the product, and the date display and the schedule interface date, etc. are operated based on the set date.
Time PM 07:27	It is the base value of the time recognized by the product, and the time display and the schedule interface time, etc. are operated based on the set time.
Controller name Scroll Chiller	Input and edit the controller's name, and the applied name is displayed at the top left side of Home screen.
Speaker OFF	It selects whether to use the touch sound.
Temperature display °F	It selects the unit of the temperature to be displayed on the controller. (°C or °F can be selected)
Language English	It selects the language displayed on the controller. (Korean or English can be selected)

- **Date**

In the System, when you press the date area, a window to set the date is displayed.

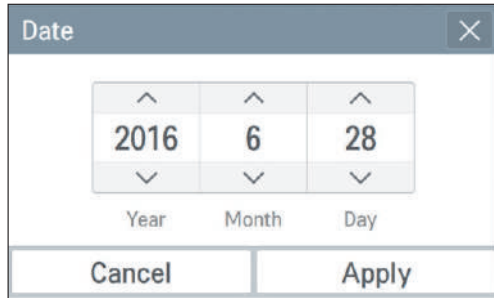

After selecting the date to set by pressing up/down button, press Apply button. If Cancel is pressed, the previous setting is maintained.

- **Time**

In the System, when you press the time area, a window to set the time is displayed.

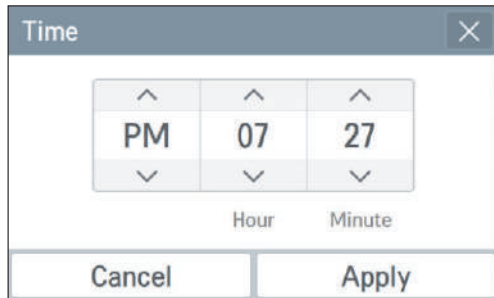

After selecting the time to set by pressing up/down button, press Apply button. If Cancel is pressed, the previous setting is maintained.

- **Controller name edit**

In the System, when you press the controller name edit area, a window to edit the controller name is displayed.

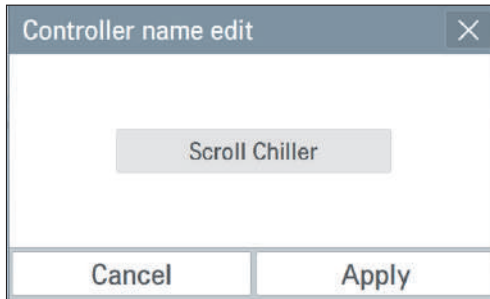

After the input of the desired name, press Apply button. If Cancel is pressed, the previous setting is maintained.

- **Speaker**

In the System, whenever you press the touch speaker area, it toggles between Use and Do not use. There is no separate Apply button.

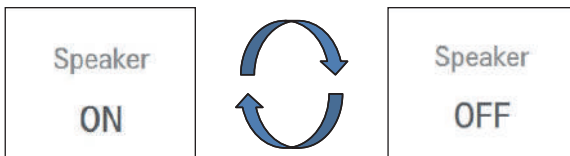

- **Temperature unit**

In the System, when you press the temperature unit area, a window to change the temperature unit is displayed.

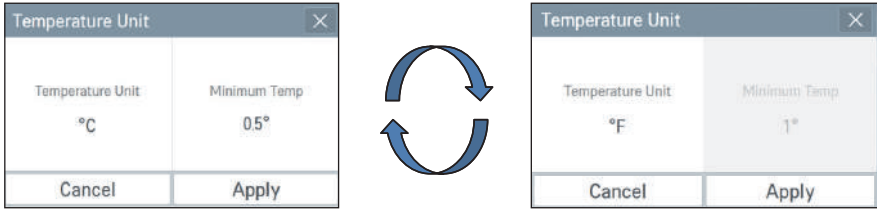

In the screen, when you press temperature unit area, the temperature unit is changed. In Celsius unit, the minimum temperature unit can be selected between 1 °C and 0.5 °C. When you press Apply, the setting is applied, and if Cancel is pressed, the previous setting is maintained.

- **Language**

In the System, when you press language setting area, the window to set the language is displayed.

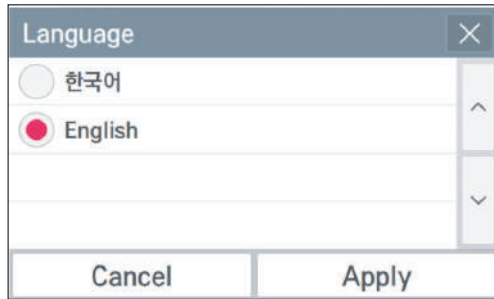

Select the desired language, and press Apply button. If Cancel is pressed, the previous setting is maintained.

System(Advance)

When you press the system icon, the System normal screen is displayed, and when you set Advance, the following screen appears.

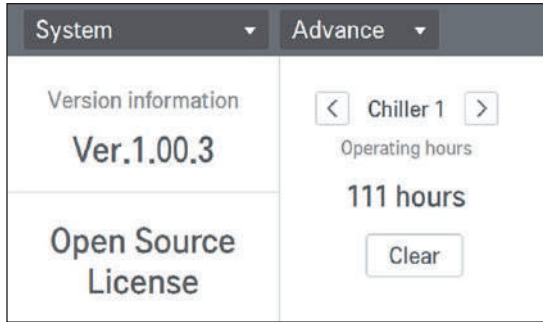

Icon	Description
Version information Ver.1.00.3	It shows the software version of the controller.
Open Source License	It shows the contents of the open source
Operating hours 1 hours Clear	It shows the overall operation time of the product. The clear function is for the service, and the customer usage is restricted.

- **Version information**

In the System advance screen, when you press Version information area, a popup window to check the version information is displayed.

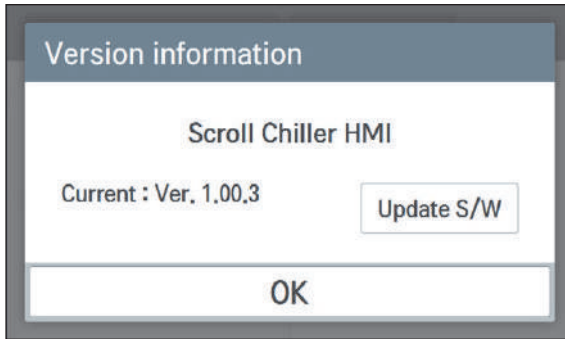

Check the current version, and when you press OK button, the popup window disappears.

- **Open source license**

In the System advance screen, when you press Open source license area, you can check the contents of Open source license.

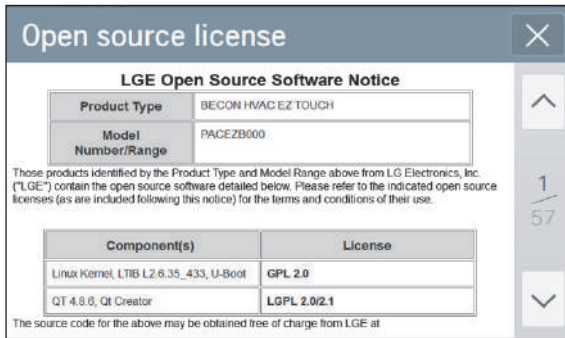

※ The clear function is for the service, and the password will not be provided to the customers.

※ Customer information about open source licenses

Visit <http://opensource.lge.com> to obtain the open source codes developed under GPL, LGPL, MPL, or other open source licenses installed in this product.

 You can download the source code as well as the contents of all applicable licenses, copyright notice, and disclaimer of warranty. If you request the open source codes for the software installed in this product by sending an e-mail to opensource@lge.com within 3 years after the purchase of the product, the code will be provided on a CD-ROM for a minimum fee used to cover the costs of the material and shipping.





Chiller interface control

This chapter describes about HMI's product interface control.

HMI can control interface to up to 5 products, and you can control and monitor up to 5 products as if it is 1 product. In Device screen, when you enter Edit Unit Address setting, you can set Count of unit and address. For detail setting method, please refer to "Edit Unit Address".





• Unit information

If you press left/right direction button  , you can check each interfaced chiller information.

Chiller Info._Chiller 1		 
Load Water Temp.		
E.W.T	0.0°C	1 3
L.W.T	0.0°C	
		

When connecting an external temperature sensor in the field in case of interface control, the temperature can be indicated as shown below.

*Refer to "How to connect external temperature sensor in case of interface control".

Unit Info._Total		 
Load Water Temp.		
E.W.T	2.0°C	1 1
L.W.T	2.0°C	
		

- **Operation**

In Chiller Operation_Total, you can set the same operation condition for all the chillers.
 For individual control, you can press left/right direction button [< >] for individual control.
 But, in individual control, you cannot change Control Mode or Run Mode.

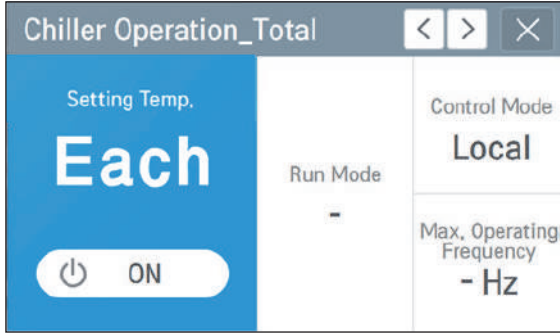

- **Cycle information**

Cycle #1	Info.		
Cycle Info._Chiller 1	A	B	
4-Way Valve	ON	OFF	^
Hot-gas Valve	OFF	ON	1/3
Sump Heater	OFF	OFF	
			v

- Error

You can check entire history _ error of the interfaced chillers.

Error					Clear
<	2016.6.28	>	Day	Week	Month
Date	Time	Address	Code	Detail Info.	
2015-09-21	04:19:07	1	14		^
2015-09-16	06:02:13	1	3		1/2
2015-09-03	00:47:19	1	14		
2015-09-03	00:47:19	1	1		v

* Individual schedule and setting are not supported.

How to connect external temperature sensor in case of interface control.

- According to the installation environment, if you want to check the inlet and outlet temperature by installing a common water pipe temperature sensor, you can check the temperature value by connecting the sensor designated by our company to a designated place.
- Connect the load inlet water temperature sensor to UI3,G.
- Connect the load outlet water temperature sensor to UI4,G.
- In case of interface control, if you select setting 2 on the device mode screen, the following screen appears.
- Set the temperature according to the specification range of the external temperature sensor. Otherwise, the temperature may be displayed differently.

Device		Setting2	
High Temperature	Condensing Temp (Water Spray)	Flow sensor Usage	Flow Rate Unit
HE Frozen error	Outdoor Temp (Water Spray)	Min Flow Rate	Max Flow Rate



CAUTION

- The type of external temperature sensor to be connected is voltage type. (0 - 10 V)
- We are not responsible for abnormal operation of external temperature and error range of temperature range during installation on site.
- External water temperature sensor specification

Power: 24 VAC

Output Signal: DC 0 - 10 V

Temperature range: -17.8 °C ~ 121.1 °C

How to connect the flow rate sensor

- You can check the current flow and set the minimum/maximum flow rate by connecting a flow sensor to the product.
- Connect the flow rate sensor to UI2,G.
In case of interface control, if you select setting 2 on the device mode screen, the following screen appears.
- Set the Flow sensor Usage to 'Use', and select the flow rate display unit (GPM or LPM) and flow rate range (Min/Max Flow rate).
(The Min flow rate must be lower than The Max flow rate, So be careful when you changing the setting.)
- You can check the current flow in System Information.

Device		Setting2	
High Tempressure	Condensing Temp (Water Spray)	Flow sensor Usage	Flow Rate Unit
HE Frozen error	Outdoor Temp (Water Spray)	Min Flow Rate	Max Flow Rate



CAUTION

- Use a flow sensor with a voltage of 0.5~10 V.
- We are not responsible for abnormal operation of the flow rate sensor and error range of the flow rate range during installation on site.

Select Setting 3 on the Setup_Installer Mode screen, and the following screen will appear.

Device		Setting3	
Pressure Unit	Start Delay Time	Flow Check Time	Pump Stop Delay Time

Icon	Description
Pressure Unit	0 : kPa, 1 : psi (Unit conversion in HMI)
Start Delay Time	<p>After the compressor operation off, a minimum delay time is required to protect the compressor life and reliability, which is a delay time with a safety device function to extend the compressor's life and increase reliability.</p> <p>When all outdoor compressors are turned off, Start Delay Time counting raises the start delay time to the HMI.</p> <p>Range: 0 to 600 seconds, [Default 180]</p>
Flow Check Time	<p>After receiving the start command, set the time to secure a sufficient flow rate after the load water pump output, and apply the input of the flow switch after this set time.</p> <p>Receive driving signals from HMI or remote signals</p> <p>During Flow Delay Time, the alarm is not considered to be alarm even if it is in the Flow Switch "OFF" state.</p> <p>Range: 0 to 200 seconds, [Default 120]</p>
Pump Stop Delay Time	<p>Delay time from stop of operation to stop of pump output</p> <p>Range: 0 to 200 seconds, [Default 10]</p>

- **Pressure unit setting**

In setting 3, if you press Pressure Unit area, Pressure Unit window is displayed.

Select the pressure unit, press the Apply button. Then, the set value is transmitted. (kPa/ psi)

If Cancel is pressed, the previous setting is maintained.



- **Start Delay Time setting**

In setting 3, if you press Start Delay Time area, Start Delay Time window is displayed.

If Cancel is pressed, the previous setting is maintained.

If the series is linked, the corresponding menu is disabled.

Select the start delay time, press the Apply button. Then, the set value is transmitted.

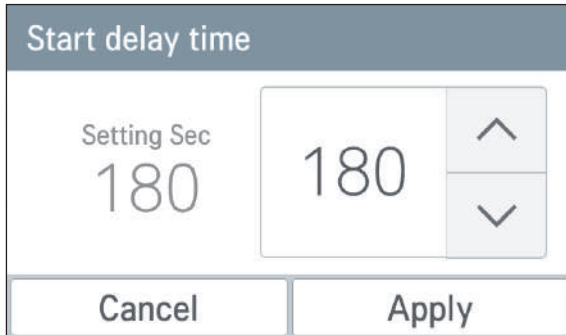

- **Flow check time setting**

In setting 3, if you press Flow Check Time area, Flow Check Time window is displayed.
Select the Flow Check Time, press the Apply button. Then, the set value is transmitted.
If Cancel is pressed, the previous setting is maintained.
If the series is linked, the corresponding menu is disabled.

- **Pump stop delay time setting**

In setting 3, if you press Pump Stop Delay Time area, Pump Stop Delay Time window is displayed.
Select the Pump Stop Delay Time, press the Apply button. Then, the set value is transmitted.
If Cancel is pressed, the previous setting is maintained.
If the series is linked, the corresponding menu is disabled.

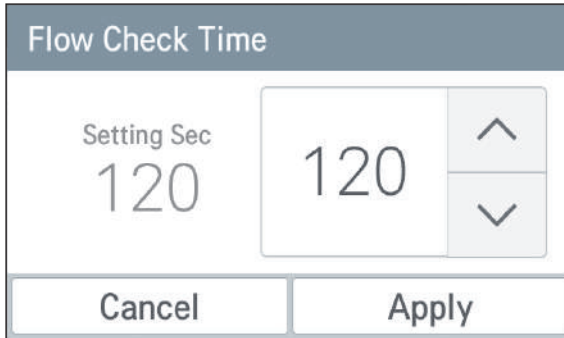

The image shows a digital display window titled "Flow Check Time". The window has a dark blue header with the title in white. Below the header, the text "Setting Sec" is displayed above the number "120". To the right of this is a larger input field containing the number "120", with an upward-pointing arrow button above it and a downward-pointing arrow button below it. At the bottom of the window, there are two buttons: "Cancel" on the left and "Apply" on the right.

FROM INSTALLATION TO TEST RUN

Flowchart from installation to test run

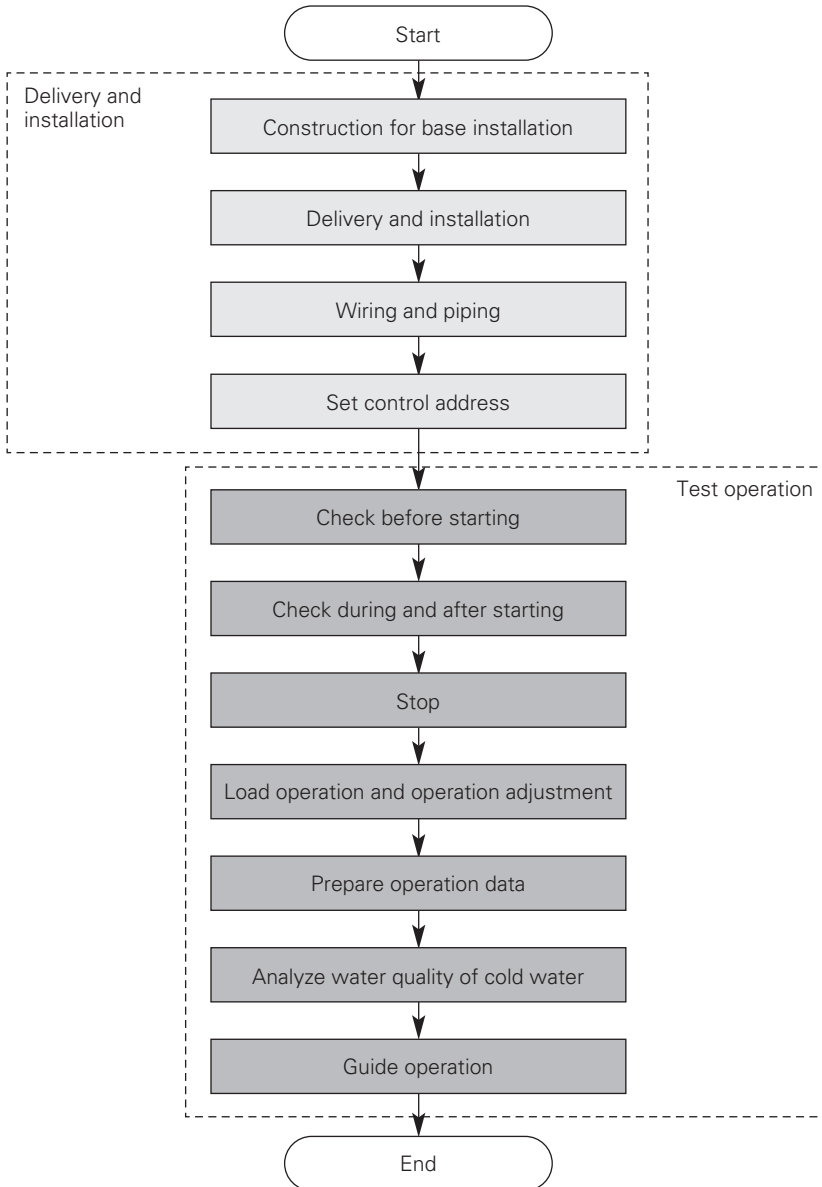

INSTALLATION

Selecting installation location

Because the user operating the product varies based on the mode setting item of the user setting, set up and operate the product as shown below.

Details to consider when selecting the installation location

Select the location that fits the following conditions to install the product.

- Location without direct heat from other heat source.
- Location where noise of the chiller does not have negative impact to the neighbors
- Check the installation direction of the unit for the seasonal wind during the winter. Install the product so that the seasonal wind does not affect only one side of the product.
- Location not exposed to strong winds
- Location that can support the weight of the chiller
- Location with space for air flow and service
- Install the boundary sign, danger sign or barricade, if necessary.
- It is recommended to install a fence around chiller so that people or animals will not be able to access the area.
- When installing the product in areas with high humidity during the winter (Coast, seaside, lake-side), install the product where it is well ventilated and has plenty of exposure to sunlight. (Ex: Roof top with sunlight)
- If the product does not run during the winter, establish a plan to use the anti-freeze for the water supply.
- To prevent the condensed water from flowing, insulate the connected evaporator and pipe.
- To smoothly drain the condensed water, establish an inclined structure.
- Avoid installing the product at locations with the following conditions.
 - Location with corrosive gas such as acid or alkali gas.
(Coolant can leak from the corroded pipes.)
 - Location with electromagnetic wave.
(It can cause the product to malfunction from defective parts.)
 - Location where flammable gas is generated or flows to prevent fire.
 - Location with high level of carbon fiber or dust
 - Special location exposed to oil, steam or emulsified gas
- For appliances intended for use at altitudes exceeding 2 000 m, the maximum altitude of use shall be stated.

Precaution for seasonal wind and winter season

In areas with heavy snow or in extremely cold areas, sufficient planning is required for the product to run smoothly.

Even in other areas, planning is required for seasonal wind during the winter season.

- Snow can go into the air discharge outlet of the condenser to freeze inside the chiller. Therefore install a large cover over the chiller for areas with heavy snowfall to prevent the snow from accumulating on the top.
- The chiller can freeze inside when the air inlet is clogged with snow. Therefore install the chiller on the base with at least twice the height of the average snow accumulation. (Default height of base: 300 mm)
- If there is more than 100 mm of snow on top of the chiller, always operate the unit after cleaning the snow.
- Do not install the product where there could be negative impact from snow in areas with heavy snowfall. Decide the installation direction of the chiller so that the side of the air heat exchanger does not face the direction of the snow. (Make the side of the air heat exchanger parallel to the direction of the snowfall.) Install a blocker with the height of the snow accumulation to avoid the snow around the chiller from being sucked into the coil side. (Prepare on site)
- If the wind comes in one direction of the unit where the seasonal wind is strong, there is a high chance that it can lead to issue with product capacity or imbalance of load. Therefore install the product so that it has consistent effect on the product cycle. If that is not possible, consider using a wind blocker or other devices. In areas with strong seasonal wind during the winter, apply the wind blocker hood, especially near the coastal area, without blocking the suction inlet of the chiller considering the direction of the wind. If the chiller is directly exposed to the seasonal wind during the winter, separately install a wind baffle. (Prepare on site)



WARNING

- Regulation for refrigerant leakage : the amount of refrigerant leakage should satisfy the following equation for human safety.

$$\frac{\text{Total amount of refrigerant in the system}}{\text{Volume of the room at which Indoor Unit of the least capacity is installed}} \leq 0.307 \text{ kg/m}^3$$

If the above equation can not be satisfied, then follow the following steps.

- Selection of air conditioning system: select one of the next
 - Installation of effective opening part
 - Reconfirmation of Outdoor Unit capacity and piping length
 - Reduction of the amount of refrigerant
 - Installation of 2 or more security device (alarm for gas leakage)
- Change Indoor Unit type : Installation position should be over 2 m from the floor (Wall mounted type → Cassette type)
- Adoption of ventilation system : Choose ordinary ventilation system or building ventilation system
- Limitation in piping work : Prepare for earthquake and thermal stress

Details to consider when installing on the coast

! CAUTION

- When installing the chiller near the coast, make sure that it is not directly exposed to the coastal wind.
- When installing the chiller directly exposed to the coastal wind, separate anti-corrosive treatment must be done on the condenser of the chiller.

Selecting location of chiller

Install the chiller where the building can block the coastal wind.

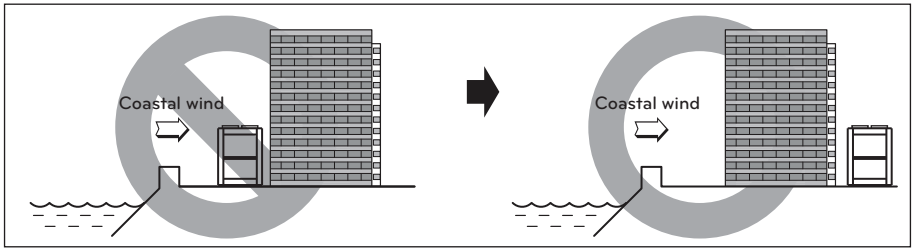

If the product has to be installed inevitably facing the coast, install a wall around the outdoor unit.

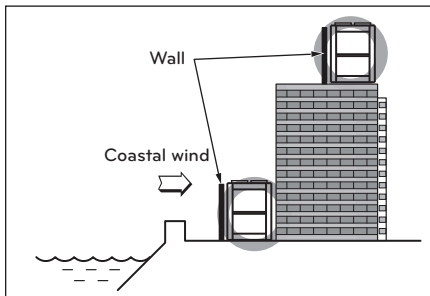

The wall must be made of sufficiently strong material such as concrete to block the coastal wind and must be 1.5 times larger than the size of the product to protect the product 1 000 mm apart. There must be 1 000 mm of clearance between the wall and the chiller for smooth circulation of air.

Install the product where the drainage is smooth.

Basic installation space

When installing the product, secure minimum space as shown below considering the service, suction and discharge of air flow.

Consider the ventilation condition.

The air cooled chiller must be installed on open space or must have appropriate ventilation. When installed along the wall, there must be sufficient space for ventilation.

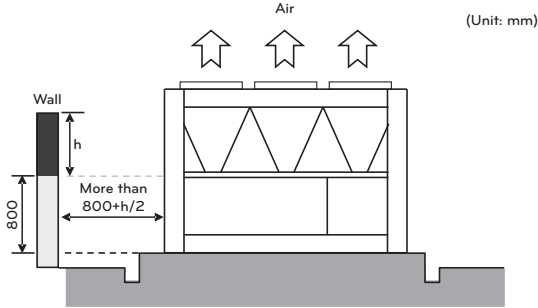

Reference

If the side of the chiller is near the wall and the height of the wall is less than 800 mm, the distance between the wall and the chiller must be at least 800 mm. If the side of the chiller is near the wall and the wall is 800 mm or higher, space of half of h must additionally be secured on top of the 800 mm for the distance between the wall and the chiller.

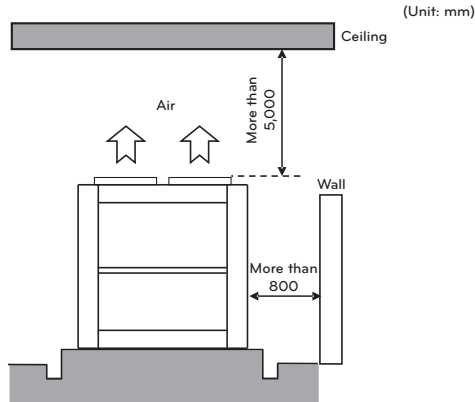

Reference

If there is a ceiling on the top part of the chiller, the distance from the chiller to the ceiling must be 5 000 mm or above.

If the front or rear side of the chiller is close to the wall, the distance from the wall to the chiller must be 800 mm or above.

Consider the service space.

There must be sufficient space for maintenance and repair work around the chiller.

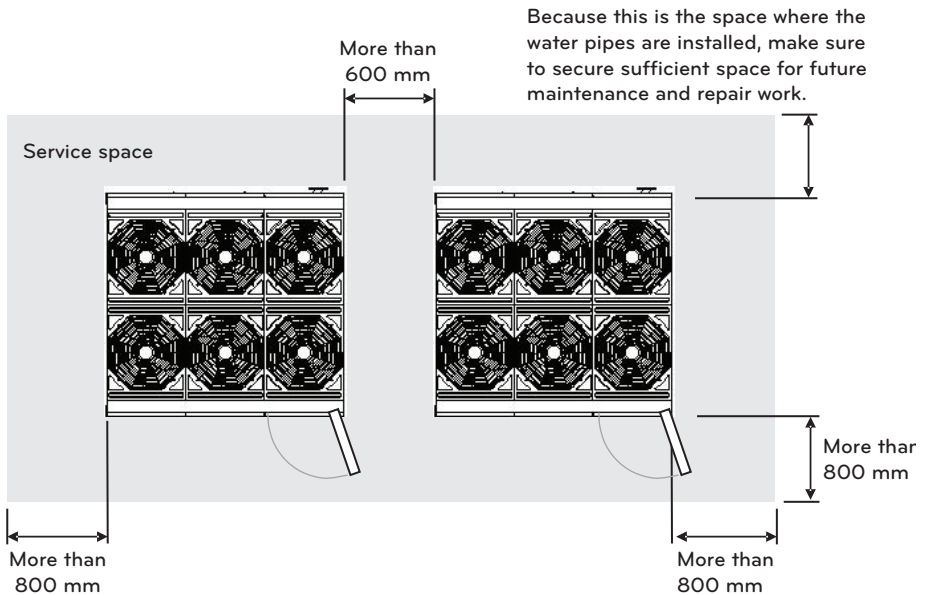
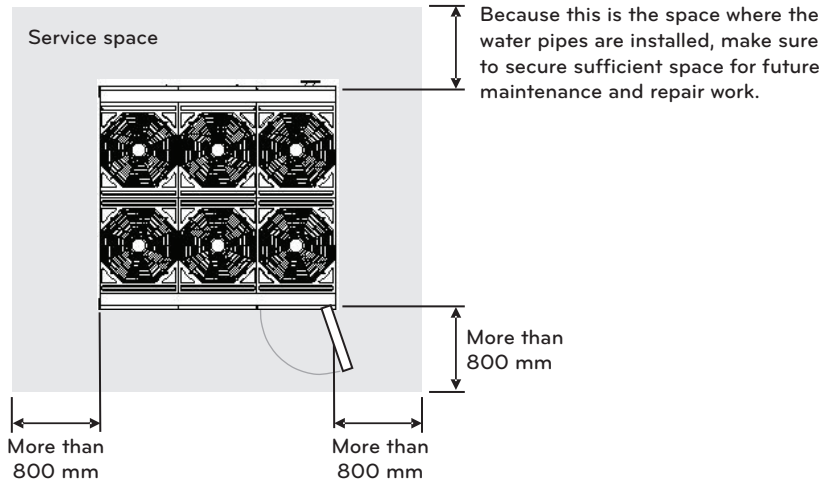

Details to consider when installing the base

- The base must be able to withstand concentrated load.
- The base must be installed with maximum gradient of 1/300.
- The height of the base must be higher than the surface of the water and drain holes must be installed around.
- Set the height of the base according to the installation environment so that the product is not submersed in water. The default height of the base is 200 mm and it must be at least doubled in areas with double the snowfall of 100 mm or above.
- Install the drain pipe in the drain hole.
The drainage must be finished so that particles around the drainage do not clog the pipes.
- LG is not responsible for product failure or damage from incorrectly designed or manufactured base.

CAUTION

- For the frame, use strong material such as steel angle so that it does not slip from the wind or snow.
- Never install the product so that the suction inlet and the discharge output of the chiller faces the seasonal wind.
- When making the base platform, pay special attention to the strength of support, drainage and direction of pipe and wiring.

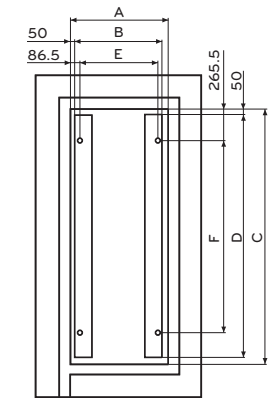

(Unit : mm)

* Location of anchor bolt

Classification	1 UNIT	2 UNIT	3 UNIT
A	977	1 740	2 503
B	877	1 640	2 403
C	2 300	2 300	2 300
D	2 200	2 200	2 200
E	804	1 569	2 330
F	1 769	1 769	1 769

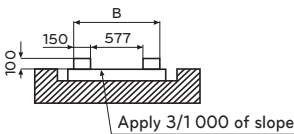

<1 UNIT Drawing of base>

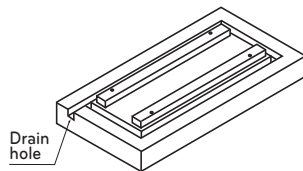

(Unit : mm)

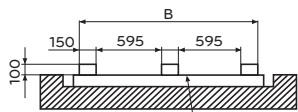
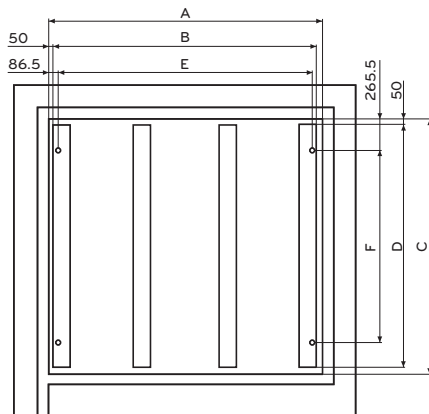
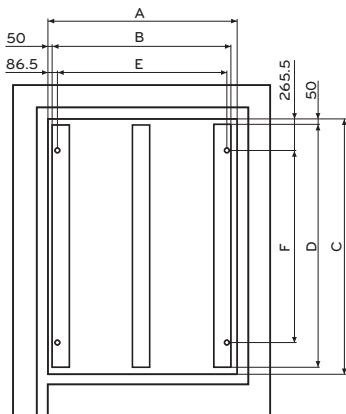

Apply 3/1000 of slope

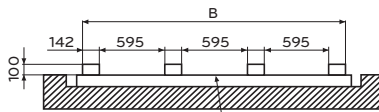

Apply 3/1000 of slope

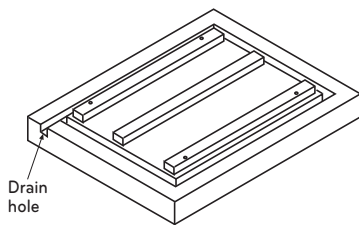

<2 UNIT Drawing of base>

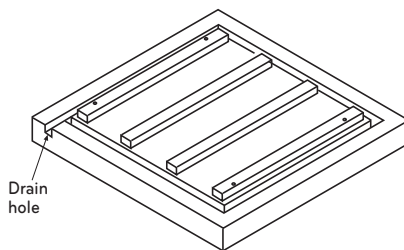

<3 UNIT Drawing of base>

Transportation method and precaution

! CAUTION

Be very careful when transporting the product.

- When transporting the product, use the forklift or spreader bar and follow the directions in the manual.
- Do not touch the heat exchanger pin with bare hands. It is very sharp and can cause an injury.
- Cut and dispose the plastic (vinyl) bag used for packaging so that children do not play with the bags. If not, it can cause suffocation when put over the head.
- Always transport the chiller by supporting 4 points. 3 point support is unstable and the product may fall over.
- When transporting the product with the forklift, be careful not to drop the product.
- Use a long belt at least 8 m long.

Precaution when moving the forklift

- Level the chiller as much as possible while moving it.
- When moving the chiller using the forklift, check the weight and use the forklift with the sufficient capacity to handle the weight.
- When moving the chiller using the forklift, check the transportation groove at the bottom of the chiller and use the fork that fits the grooves.
- The forklift cannot lift the product from front or rear side. Always lift the product up from the side where the grooves are to move the product.

* The side with the control box is the front side.

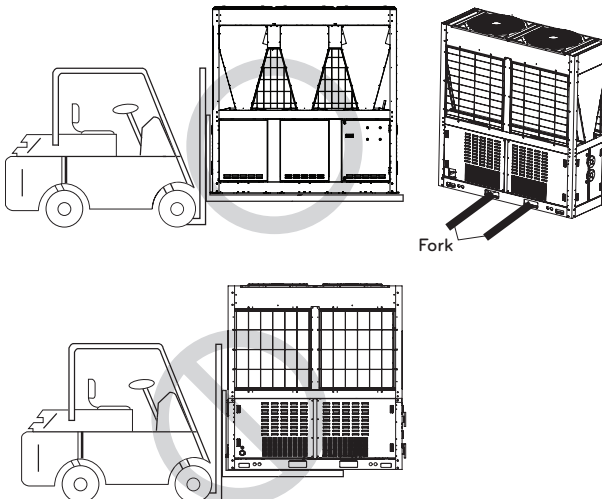

When transporting the product, the fork must be inserted into a wooden pallet, not the frame of the product body.

(Unit : mm)

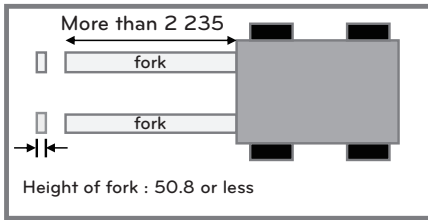
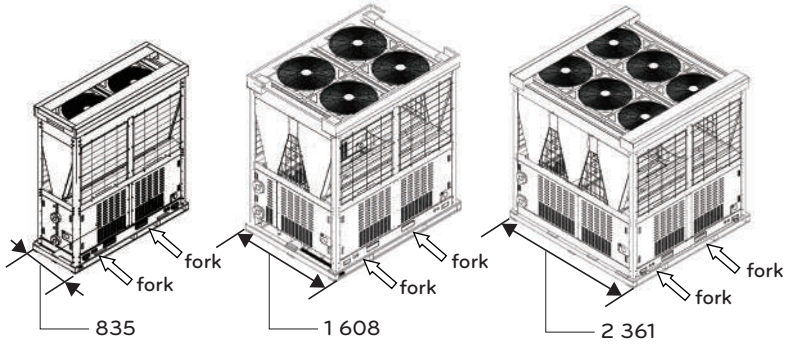

Precaution when hanging the product

- When moving the chiller, make sure to level the product as much as possible.
- When hanging the chiller, pass the rope through the two supports located at the bottom of the front and rear side.
- Always connect the rope to the 4 supports when lifting up the product so that the impact may not be applied.
- Use the steel spreader bar to use the tension of the ropes to avoid the damage to the product.
- When hanging the chiller, do not tilt the chiller by more than 15 degrees.

Spreader bar is the tool to avoid the rope from contacting the product to minimize the damage to the top and the coil.

- Spreader bar is not supplied.
- Spreader bar must be larger than the size of the chiller.
- Even when the spreader bar is close to the top of the product, it must not contact the product.

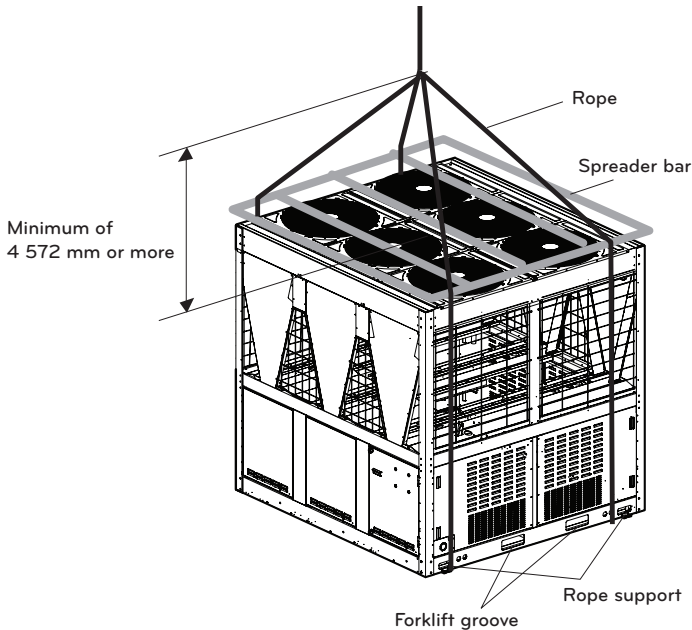

Storage

If the product must be stored before being installed or used, make sure not to expose the product to dirt and humidity in the construction site. Put a protective cover on the product until it is ready to be installed.

Installing chiller

As soon as the product is delivered, check for any damages. If there are damages, immediately contact the shipper.

Precaution when installing the chiller

- Secure air flow, wiring, piping and sufficient space for service.
- Check whether the surface is flat and can withstand the operating weight and vibration/noise of the device. (For the part to lift up the product, installation and operating weight, refer to the specification, external diagram and basic diagram.)
- Set the device so that the air flow does not get limited to the suction inlet side only.
- Secure sufficient space to provide service and remove the product. (The air flow and service space various based on the model. Refer to the drawing in the Appendix.)
- Check the base before installing the product and install the product only when there is no issue. If there is any issue, contact the contractor to resolve the issue. (For checkpoints related to the base, check the details when installing the base.)

! WARNING

- Install the product where the weight of the chiller can be sufficiently supported. If the product is installed at a location that cannot support the weight, the chiller can fall down to cause an injury.
- Install the chiller so that it does not fall over even from strong wind and earthquake. IF there is any defect in the installed condition, it can fall over to cause an injury.

Installing anti-vibration pad

- Anti-vibration pad is the part to absorb the vibration that occurs during the product operation and must be installed before placing the product on the base. Anti-vibration pad is not provided along with the product and must be supplied on site.
- After installing the anti-vibration pad, loosely tighten the anchor bolts. Tightening the anchor bolts too tightly will reduce the anti-vibration effect.
- Locate the anti-vibration pad shown as below and lay 2 layers of 10 mm or above.

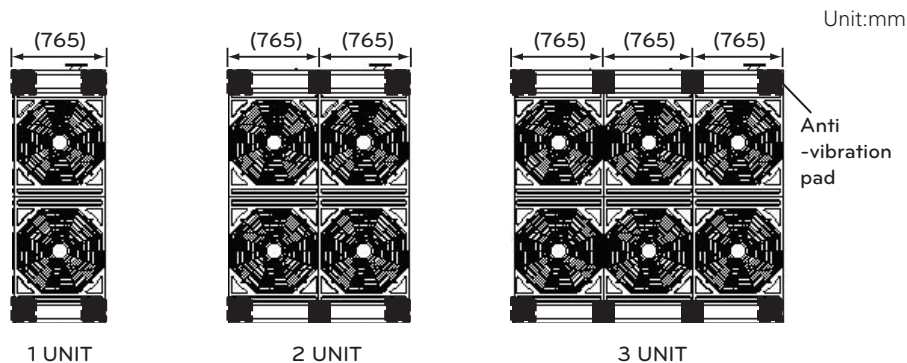

Installing anchor bolt

! CAUTION

- Wooden frame at the bottom of the base frame must be removed before tightening the anchor bolts for the chiller.
- When installing the chiller where it is directly affected by the coastal wind, additional anti-corrosive treatment must be applied to the condenser.

- Tighten the bolts so that the chiller does not fall over from the earthquake or strong wind as shown below.
- Depending on the installed condition, the vibration can be transferred to the installed part to transfer the noise and vibration to the floor or wall. Therefore make sure to use the anti-vibration material.
- Anti-vibration spring can be additionally installed on top of the anti-vibration pad. Check the external diagram and the weight of the product to set the specification for the anti-vibration spring.
- When combining multiple chillers, make sure to level the height of each chiller so that the water pipes can be easily connected.
- Use the anchor bolts to firmly fixate the chiller. The anchor bolt must be inserted at least 65 mm.
- Open left/right panel of the chiller, check anchor bolt fixing hole, and lock the anchor bolt so that it makes right angle with the chiller.

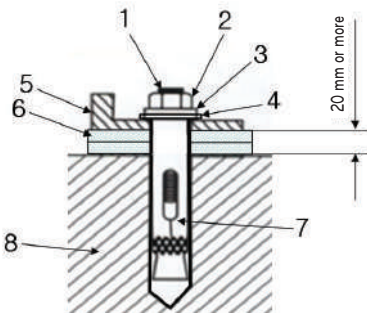
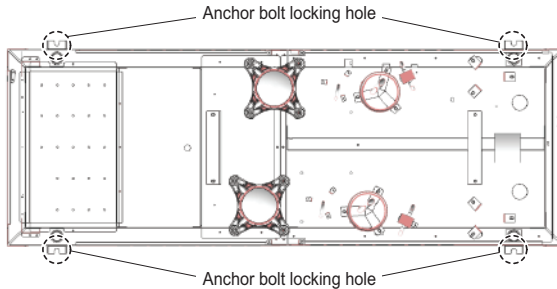

No.	Name
1	Anchor bolt(M16)
2	Nut
3	Spring washer
4	Flat washer
5	Bottom of product
6	Anti-vibration pad
7	Cap
8	Base surface

* Above parts are not included in the product.

Shape of anchor bolt

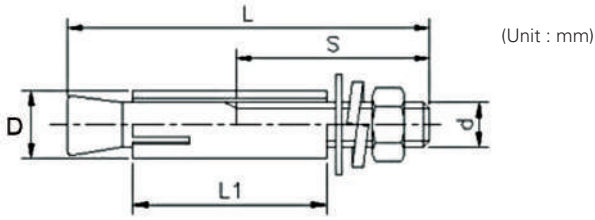

Specification of anchor bolt

Screw size (d)	L	S	D	L1	Used drill	Drill depth (mm)	Pull-out load(N)
5/8" (M16)	125	70	22	65	22	65	42 140

Weight by Position

<1 UNIT>

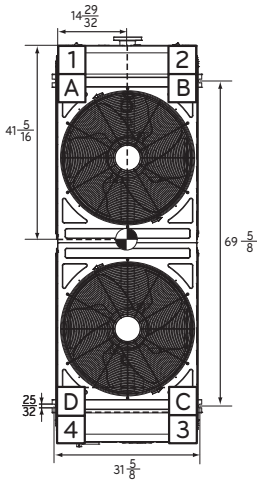

Location	Weight (kg)
1 or A	134.4
2 or B	128.1
3 or C	124.2
4 or D	123.0

<2 UNIT>

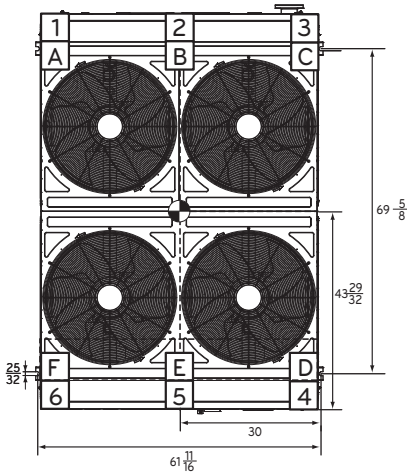

Location	Weight(kg)
1 or A	218.7
2 or B	50.2
3 or C	225.2
4 or D	204.1
5 or E	44.5
6 or F	206.8

<3 UNIT>

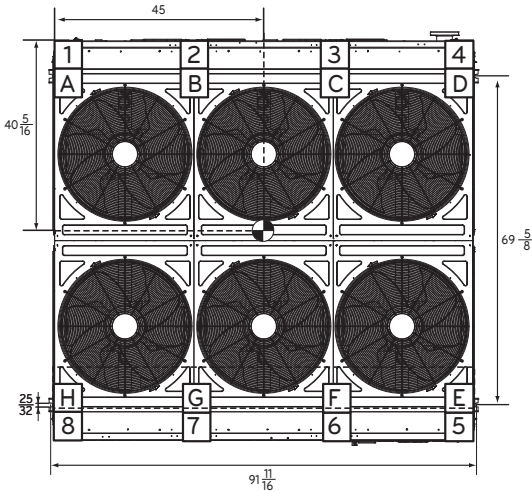

Location	Weight(kg)
1 or A	298.1
2 or B	64.7
3 or C	67.0
4 or D	300.9
5 or E	261.8
6 or F	64.6
7 or F	64.5
8 or F	268.6

Snow protection

Areas with heavy snowfall require snow protection plan. For the air cooled scroll cooling only chiller, the snow protection plan ensures sufficient performance.

Design of snow protection plan

When establishing the snow protection plan, the fan level from the chiller must be at least to some level.

- If the fan level is below a certain level, it triggers the high pressure limit within the circuit to cause an issue in the operation.
- Because the outdoor unit can be frozen inside due to the clogged air inlet from snow, make the arrangement so that the outdoor unit does not directly contact the inlet and install the hood to avoid the effect of the heavy snow.
- Always install the base so that the chiller can be installed higher than the accumulated snow and the default height of the base is 200 mm. If the snowfall is 100 mm or above, raise the base to more than double the height. (300 mm maximum snowfall)
- The height of the base must not exceed the width of the product.
- If there is 100 mm or more snow piled on top of the product, make sure to clean the snow off before operating the chiller.

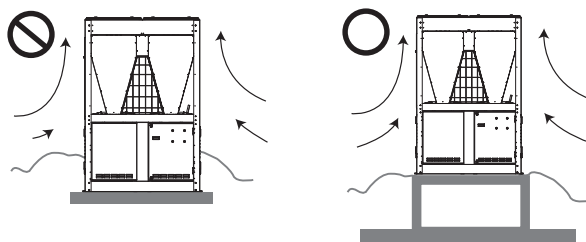

Installation considering the snow protection

- Do not install the chiller near the edges of the rooftop. (Snow can fall down to the chiller and push off the chiller off the roof. If snow is accumulated between the building wall and product, it can cause issues with the product.)
- Raise the base higher than the snow accumulation. (Make sure to secure the path near the heat exchanger of the chiller in case of snow)
- Avoid installing the product where the snow is accumulated.

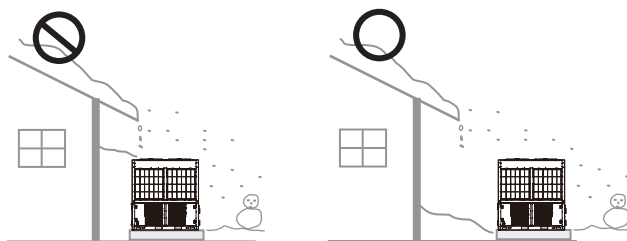

Water pipe connection

Water pipe construction is a very important part of the design or construction of the cooling system. Any defect in any location of the pipe can disable the applicable unit from performing sufficiently. Perform the design and construction considering the check service.

Water pipe system diagram

Water circulation that has temperature difference of 3 °C - 8 °C between the outlet water temperature of the hot and cold water is required. If the water circulation is insufficient, the product will not be able to perform properly and will have negative impact on the life of the product, as well as other issues with the product.

Make sure to secure water circulation in accordance with the specification.

Also even when the water circulation is secured in accordance with the specification, bypass circuit must be installed on the 1st side for the water pipe system of the chiller.

Therefore if the water flow is reduced during low load, it can cause issues such as excessive and frequent operation of compressor and freezing during stopped condition or cooling operation.

Water circulation must maintain constant flow as much as possible.

* For the parts used in the cold water pipe system, make sure to use the parts that comply with designed water pressure or higher.

Expansion tank

Expansion tank is the device that discharges the expanded water and at the same time, removes the air within the water pipe circuit.

Set the capacity of the expansion tank to 2-2.5 times of the water expansion amount. (Generally it is 3-5 % of the entire amount within the water pipe circuit.)

Pipe slope and air vent

If air remains within the pipe, the resistance of the water pipe circuit increases or the circulating amount of water is reduced significantly. If air remains in the pump during the operation, it can cause several issues to disable the operation.

Install the air vent valve where there is a chance of air remaining within the entire water pipe circuit and apply 1/200 of slope to the air vent valve side to avoid the air from remaining in the pipe.

Water pipe system diagram

- Connect the pipe so that the entrance of the cold (hot) water pipe is correct.
- Permitted water pressure resistance of cold water pipe system is 1MPa
- To prevent any external heat loss or dew drops forming during the cooling operation on the water pipe system, apply thermal insulation treatment.
- Install the air vent at the output end of the water pipe. (Air vent)
- If the thermometer is installed on the inlet/outlet of the cold/hot water pipe, the operating condition of the chiller can be checked.
- Always install the strainer (30 Mesh or above) that can be cleaned on the water pipe inlet side to filter any alien particles from entering the heat exchanger.
- Always install the strainer on the leveled pipe. (If sand, trash or rust gets mixed to the cold water system, it can cause product failure due to corrosion of metallic parts.)
- Install the on/off valve on the cold water inlet/outlet and bypass pipe on the pipe direction of the device side.
 - For the pipe system, it is recommended to install the bypass and clean the pipe before installing the product and during the annual pipe cleaning.
 - On/Off valve blocks the old water to the chiller that is not operating to reduce the power of the pump. Therefore select whether to install to fit the need of the site.
- Install the pressure gauge and thermometer on the inlet and outlet of the water pipe.
- Always install the flexible joint to reduce the vibration of the pipe and product.
 - Vibration of water pipe system is absorbed to prevent water leakage.
- For the cold water system part, make sure to use the component that complies with designed water pressure or above.
- Before supplying cold water to the chiller, clean inside the pipe system to remove any negative impact of particles to the product.

Installation mode A (Recommended method)

- Independent product installation

- Multiple product installation

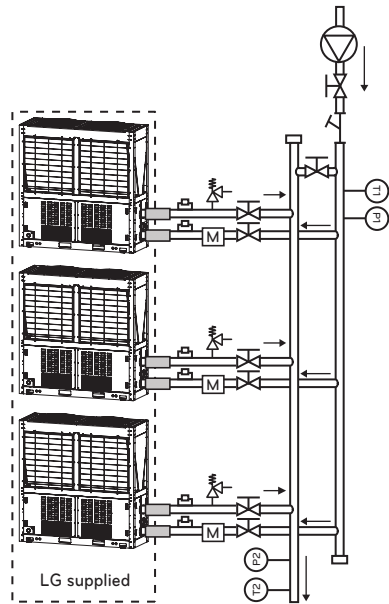
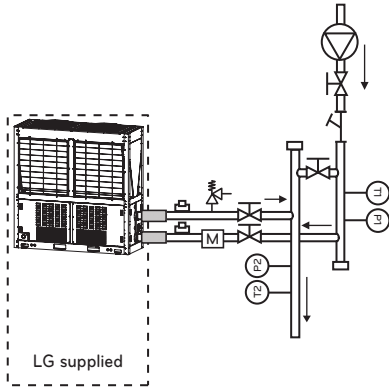

Symbol	Description	Symbol	Description
	Valve	T1, T2	Temperature sensor (1: Inlet 2: Outlet)
	Strainer	P1, P2	Pressure gauge (1: Inlet, 2 Outlet)
	Flexible joint		Cold water pump
	Service port for cleaning		Seife relief valve
	Magnetic separator		



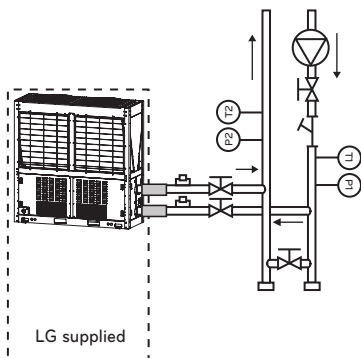

Installation mode B

- Independent product installation

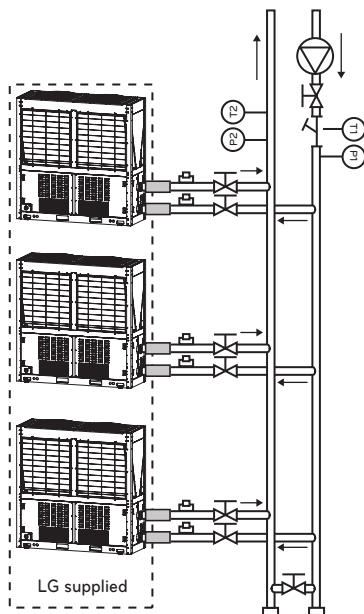

- Multiple product installation



Symbol	Description	Symbol	Description
	Valve	T1, T2	Temperature sensor (1: Inlet 2: Outlet)
	Strainer	P1, P2	Pressure gauge (1: Inlet, 2 Outlet)
	Flexible joint		Cold water pump
	Service port for cleaning		

Water cycle minimum requirements

If below components are not installed it can result in serious damage of the product.

- For selecting the components of the hydraulic system, be sure they are above the design water pressure.
- For the water pipe, diffusion-tight water pipes are recommended instead of steel pipes.
- For the drain pipe size, use the same diameter as the product connected or larger.

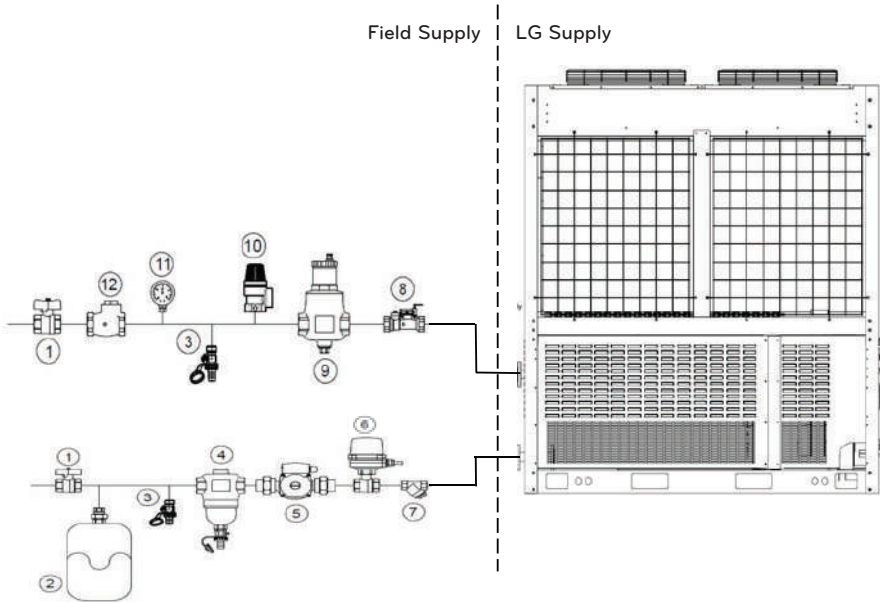

1	Shut-Off valve
2	Expansion tank
3	Service port
4	Magnetic dirt separator
5	Pump
6	Flow switch
7	Strainer
8	Balancing valve with flow meter
9	Automatic air separator
10	Pressure safety relief valve
11	Pressure meter
12	Check valve
13	Buffer tank

- For selecting the components of the hydraulic system, be sure they are above the design water pressure.
- For the water pipe, diffusely tight water pipes are recommended instead of steel pipes.
- For the drain pipe size, use the same diameter as the product connected or larger. Always install a natural drainage so that the drained water does not flows back
- Install insulated material across the total hydraulic piping to prevent condensation and to prevent low cooling or heating capacity during heat transfer losses. If the temperature is higher than 30°C and the humidity is higher than 80% the insulation material must be minimum 20mm thick to prevent condensation.
- Install the shut-off valve (1) to block the water by closing the valve when replacing the component or cleaning.
- Install an expansion tank (2) based on the water volume of the hydraulic system.
- Install the drain valve (3) that can be used for draining the water inside when replacing the component or providing service.
- Install a magnetic dirt separator (4) at the inlet water pipe
If the air separator is not installed there can be formed air bubbles inside the hydraulic system. Flow error will be showed first on remote controller, however finally a plate heat exchanger may burst during combined circumstances.
- Install a circulation pump (5) which meets the water flow specifications mentioned inside product data book.
- Install a flow switch (6) which is adjust based on the minimum water flow rate mentioned inside product data book.
- Install the strainer (7) at the inlet water pipe connection to protect the PHE.
Do not charge water into the water pipe directly during Hydro Kit operation.
If the strainer is not installed, component malfunction of Hydro Kit may occur.
- For the strainer, use one with 50 mesh or above with measurement diameter of 0.4mm or less.
- Always install the strainer on the horizontal pipe.
- Install a balancing valve with flow meter (8)
- Install an automatic air separator in the outlet water pipe (9)
- Install pressure safety relief valve (10) in vertical upright position that meets the design water pressure to prevent unit or water pipe damage
- Install a thermometer (11) in the outlet water pipe.
- Install in case of cascade hydraulic systems or bivalent systems a flow-check valve (12) at each outlet water pipe.
- Install a buffer tank (13) of at least 10L/kW heating capacity in order to have a correct defrost cycle, if there is no knowledge about the type an dimensions of the heating system. If there is no buffer tank installed, the product can be damaged during normal operation or defrost operation.
- After product operation for 2 weeks in case of new installation, clean the water filter. In the beginning of operation small particular dirt from installing process can block the filter which can lead to damage of the product.
- In any case take in mind to add Glycol inside hydraulic circuit.

Water pipe connection

CAUTION

- If the winter outdoor temperature is 0 °C or below, take following measures to prevent the pipe from freezing as shown below.
 - If the outdoor temperature is low, the circulation water can freeze to damage the heat exchanger of the product when the product is stopped.
If there is possibility of damage from low outdoor temperature, operate the pump to prevent the water from freezing.
 - If the product does not operate for a long period of time during the winter season, remove all the circulation water to prevent the damage of heat exchanger and pipe from freezing.
 - Add anti-freeze additive to prevent the circulation water from freezing during the winter season.
- Maintain the cold water flow within the designed flow to ensure appropriate chiller performance and reduce the tube damage from rusting, scaling and corrosion. LG is not responsible for any damage of chiller from poor water quality management or inappropriate processing water.

1 Water pipe installation

- Appropriate pressure of pipe connection is flange connection of 1 MPa or below.
- Size of the water pipe must be the same as that of the product or larger.
- If there is risk of dew drops forming, always install the thermal insulation material on the outlet pipe of the cold water.
- To avoid connected water pipe from creeping from the load, use appropriate hook for support.
- To prevent the pipe connected part from freezing during the winter season, always install the drain valve at the most bottom of the pipe system.
- Cold water inlet pipe is located at the bottom and the outlet pipe is installed on the top.
- After connecting the water pipe, the connection must be covered with at least 25.4 mm of insulation.
- When connecting the water pipe, remove the rear panel and connect.

2 Cold water pump control

- If the cold water pump is not operating for a long period of time or if the anti-freeze liquid is not used as the cold water, the anti-freeze pump control must be installed to prevent the pipe from freezing.
- The vibration of the pump can transfer to the pipe to cause noise indoors. As the plan to prevent the noise from spreading in the pump, install flexible joints at the inlet/outlet and use the anti-vibration amount for the pump support.

3 Cold water management

The water quality of the cold (hot) water is described as follows. The water quality must not fall below the following standard. If so, it can be judged to have risk within relatively short period of time.

Item		Cold water	
		Circulation type cold water	Cold water
Reference	PH(25 °C)	6.5 - 8.0	6.5 - 8.0
	Conduction rate (25 °C μs/cm)	500 or below	200 or below
	Alkali level (PPM)	100 or below	50 or below
	Hardness (PPM)	100 or below	50 or below
	Chlorine ion (PPM)	100 or below	50 or below
	Lactic acid ion (PPM)	100 or below	50 or below
	Iron (PPM)	0.1 or below	0.3 or below
	Sulfur ion (PPM)	Not detected	Not detected
	Ammonium ion (PPM)	0.5 or below	0.2 or below
	Silica (PPM)	50 or below	30 or below

KCHH***LDGC	Operating maximum pressure (kPa)	Pressure drop (Water) (kPa)	Minimum water volume (L)
17	Refrigerant : 4 118 Water : 980	18.7	395
20		21.5	450
23		28.7	512
33		18.7	789
40		21.5	900
45		28.7	1 025
50		18.7	1 184
60		21.5	1 350
67		28.7	1 537

- To maintain stable operation and outlet temperature, the minimum amount of water must be secured.
- Be sure to use cold water piping system accessories that have a water pressure higher than the design.

Precaution to prevent freezing

If the product does not run when the outdoor temperature is 0 °C or below during the winter, the water must be drained or anti-freeze additive must be added to prevent the water from freezing.

Input pipe must be installed to be leveled.

The pipe must be leveled and installed so that water does not remain in the inlet pipe connected to the product when draining the water through the drain hole.

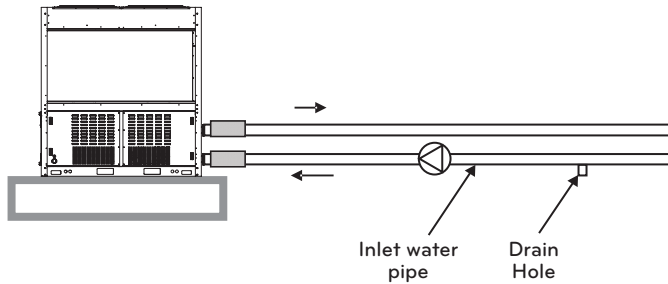

If the inlet water pipe is installed in trap structure without being leveled, the water will remain in the inlet water pipe even when the pipe is drained and the inlet water pipe or the part within the chiller can be damaged from freezing. Therefore add a drain hole at the bottom of the pipe as shown below.

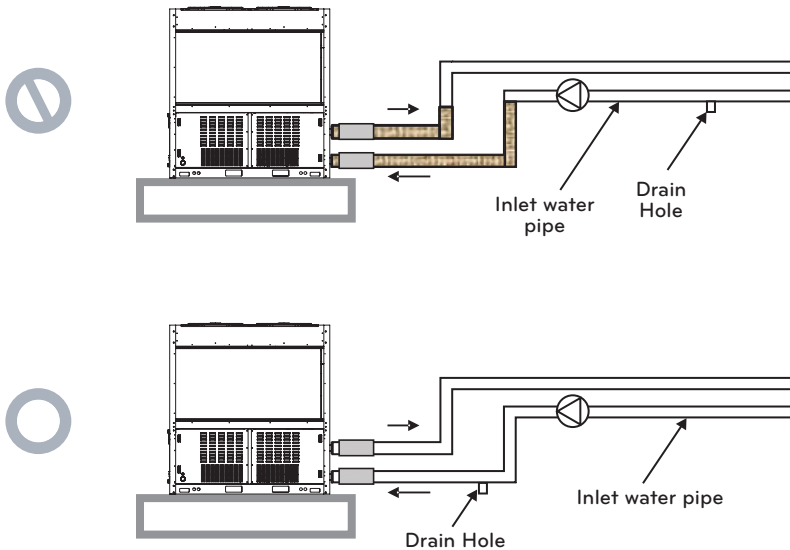

If you do not operate the product when the outside temperature in winter falls below freezing, you must remove water from the pipe or operate a pump to prevent the water from freezing.

- Adopt the following methods to prevent freezing. Otherwise, there is a risk of freezing in winter.
 - Use ethylene glycol-based or propylene glycol-based antifreeze (freeze inhibitor)
 - Keep the concentration of the antifreeze below the freezing temperature of -15 °C
 - ※ Freezing temperature -15 °C concentration standard :
 - Ethylene glycol : More than 30%
 - Propylene glycol : More than 35%
- Glycol Solution is required for Freezing temperature operation at or below 5 °C
(See table for percentage of glycol concentration as a function of outdoor temperature)

Freezing temperature	Ethylene glycol	Propylene glycol
-3°C	10%	10%
-7°C	20%	20%
-15 °C	30%	35%
-20 °C	40%	40%
-25 °C	42%	45%
-30 °C	45%	50%

- Ability correction factor according to antifreeze content

Antifreeze	Classification	Volumetric concentration (%)					
		10	20	30	35	40	50
Ethylene glycol	Cooling capacity	0.996	0.991	0.987	0.985	0.983	0.979
	Heating capacity	0.993	0.985	0.977	0.973	0.969	0.961
	Pressure drop	1.024	1.068	1.124	1.156	1.188	1.263
Propylene glycol	Cooling capacity	0.993	0.987	0.980	0.977	0.974	0.968
	Heating capacity	0.986	0.973	0.960	0.954	0.948	0.935
	Pressure drop	1.040	1.098	1.174	1.224	1.273	1.405

- Precautions when using antifreeze

- If you want to use an antifreeze other than ethylene glycol or propylene glycol, contact us or the installation store
 - For all circulating water (antifreeze) and additives (corrosion inhibitor, antifoam agent, etc.), please contact us or an installation specialist for environmental impact, toxicity, corrosiveness, harm to human body, maintenance plan, etc
 - The installer must pay special attention to the rules and regulations applicable to the handling, packaging and transportation of antifreeze
 - Do not use a heating medium other than the specified antifreeze.
 - When using antifreeze, it must be used according to the specified type and concentration. (Direct injection of the undiluted solution is prohibited. When bringing the undiluted solution into the field, be sure to consult with the project owner or supervisor)
 - Before injecting antifreeze, remove any air that may remain in the system, then apply pressure to check for leaks
 - If left unattended, antifreeze absorbs moisture in the air and the concentration decreases, which can lead to freezing of heat exchangers and water pipes. must be maintained
 - After draining the water in the water pipe system, rinse thoroughly with clean water
 - Inject antifreeze in an undiluted state and keep the freezing temperature below -15 °C with water injected. Note that if the concentration of antifreeze is increased, the pumping ability will decrease due to viscosity and specific gravity. The concentration of antifreeze should be controlled by measuring it with a densitometer.
 - Be careful not to leak the antifreeze, and if there is a leak, the antifreeze should be replenished
 - When antifreeze is added, it cannot be used for hot water supply or food.
 - Check the concentration of antifreeze regularly (at least once a year) and check the concentration before winter to prevent freezing
 - When using antifreeze, the type and concentration of antifreeze specified by us must be used.
- ※ Freezing temperature -15 °C concentration standard :
- Ethylene glycol : More than 30%
 - Propylene glycol : More than 35%

Electric specification

KCHH***LDGC	Voltage (V)	Voltage range (V)	MCA (A)	MFA (A)	COMP		Fan Motor		Frequency (Hz)	Input Power (kW)
					MSC (A)	RLA (A)	MSC (A)	RLA (A)		
17	380~415	323~477	50.9	60.0	12.6	25.4	3.0	2.0	50	18.4
20	380~415	323~477	50.9	60.0	12.6	30.2	3.0	2.0		21.7
23	380~415	323~477	50.9	60.0	12.6	37.4	3.0	2.0		26.4
33	380~415	323~477	101.8	125.0	25.2	50.8	6.0	4.0		36.8
40	380~415	323~477	101.8	125.0	25.2	60.4	6.0	4.0		43.3
45	380~415	323~477	101.8	125.0	25.2	74.8	6.0	4.0		52.9
50	380~415	323~477	152.7	175.0	37.8	76.2	9.0	6.0		55.2
60	380~415	323~477	152.7	175.0	37.8	90.6	9.0	6.0		65.0
67	380~415	323~477	152.7	175.0	37.8	112.2	9.0	6.0		79.3

1 Voltage range

The chiller must be operated at the voltage within the upper and lower limit supplied from the power terminal to operate normally.

2 Maximum voltage variance permitted between phases is 2 %.

NOTE

MCA: Minimum Circuit Ampere, A

MFA: Maximum Fuse Ampere

RLA: Rated Load Ampere

MSC: Maximum Start Current

! WARNING

- Pipes and wires should be purchased separately for installation of the product.
- Always use regulated wire so that the connector of the terminal does not fall off from external force. If the connector is not fixed firmly, it can cause heating, resulting in a fire.
- Always use appropriate over-current protection switch. Generated over-current includes low level of DC.
- Leakage current circuit breaker for grounding must be installed. If not installed, it can cause electric shock.
- Use only the circuit breaker and fuse of accurate capacity. Using fuse, wire or copper wire with excessive capacity can cause malfunction or a fire.
- Do not connect the 3 phase 4 wire type connection in reverse/missed phase.

Electric work

Precaution

- 1 For regulation related to electric device and wire, follow the regulation of the technical standard and government organization and the guide of the power company.

! WARNING

Electric work using special circuit based on the overall regulation and this manual must be done by qualified electrician.

If the capacity of the power supply circuit is insufficient or if there is a defect, it can cause electric shock or fire.

The appliance shall be installed in accordance with national wiring regulations.

- 2 Directions of Power and Communication cable connections differ depending on the product volume.

1UNIT and 2UNIT use the connection terminals located at the right when viewing from the front. 3UNIT uses the connection terminals located on the left.

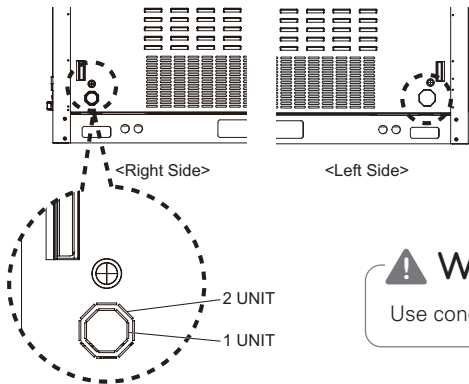

! WARNING

Use conduits for power cable installation.

- 3 Separately install the communication and power cable of the chiller so that the communication cable is not affected by the electric noise generated from the power cable. (Do not pass through the same electric pipe)
- 4 Always ground the wires as indicated.

! WARNING

Always ground the chiller. Do not connect the grounding wire to the gas pipe, water pipe, lightning rod or telephone grounding wire. If the grounding is unstable, it can cause electric shock.

- 5 Use 2-line shield cable as the communication cable. If 1 line shield cable is connected to another system, the communication quality of receiving and sending will be poor causing issues.

! WARNING

- When connecting the power cable, always connect after connecting the ring terminal. It can cause fire and burn the electric part.
- The voltage imbalance rate between phases must not be higher than 5 %. If higher than 5 %, the product life may be shortened.
- Use 2 line shield cable
- Do not wire in parallel to the power cable.
- Do not use multiple lines.

6 For the communication terminal, use only the regulated communication cable.

Electric connection

! WARNING

Electric shock may result in injury or death. The power must be completely turned off while installing the product.

Because there may be more than 1 switch, attach the warning label to all locations with the switch so that the power is not recovered until the work is fully completed.

1 Power

The electric characteristics of the power must be aligned with plate of the device. Supplied voltage must be within labeled limit.

2 Power cable connection and wiring.

Refer to the wiring diagram to connect the power cable.

Connect R, S, T, and N of the power cable separately to the circuit breaker in case of 1UNIT or to Main terminal block in case of 2UNIT or 3UNIT.

All power wiring must comply with the regulation of the applicable area and nation. Refer to the wiring diagram and electric specification.

Do not turn off the power unless the chiller is not used for a long period of time.

If power is not connected to the oil heater on the bottom of the compressor, the chiller may be damaged or the system may stop.

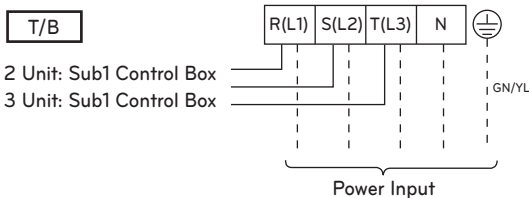

3 Control power

When using the power, control power is supplied from the main power and separate power supply is not required.

4 Additional wiring

Refer to the wiring diagram for on-site wiring. Only the main panel (HMI installed panel) requires wiring at the site. Control box is already fully wired out of the box.

* On-site wiring location

Index	Signal type	Location	Remarks
Power	DC Power	12 V DC	Necessary
Central control communication	Communication	CH2 A, B	Necessary
HMI communication	Communication	CH3 A, B	Necessary
Modbus	Communication	CH4 A, B	Optional (Field connection)
Ambient thermistor	DI	UI1, G	Necessary
Flow switch	DI	UI5, G	Necessary (Except H/P model)
Pump interlock	DI	UI6, G	Optional (Field connection)
Remote On/Off	DI	DI1, GND	Optional (Field connection)
Remote CO/HP	DI	DI2, GND	Optional (Field connection)
Remote alarm	DI	DI3, GND	Optional (Field connection)
Alarm status	DO	DO1, COM	Optional (Field connection)
On/Off status	DO	DO2	Optional (Field connection)
Pump output	DO	DO3	Optional (Field connection)
Heater output	DO	DO5	Optional (Field connection)
Water spray output	DO	DO6	Optional (Field connection)
Global water inlet sensor	AI	UI3, GND	Optional (Field connection)
Global water outlet sensor	AI	UI4, GND	Optional (Field connection)
Remote Target Temp	AI	UI7, GND	Optional (Field connection)
Remote Demand Limit	AI	UI8, GND	Optional (Field connection)

CAUTION

- Refer to “Remote desired temperature contact point table”.
- When connecting the communication wire to the controller, use pin type JOB153 for the terminal of the wire.

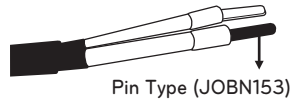

5 Circuit breaker and power cable connection

Maximum of 5 chillers can be connected.

When installing the power cable, jump one power cable and do not connect to other chiller.

Always distinguish chiller for installation.

When installing several chillers, install the circuit breaker by each chiller.

Refer to the general data of the product information when selecting the capacity for the circuit breaker.

Correct installation

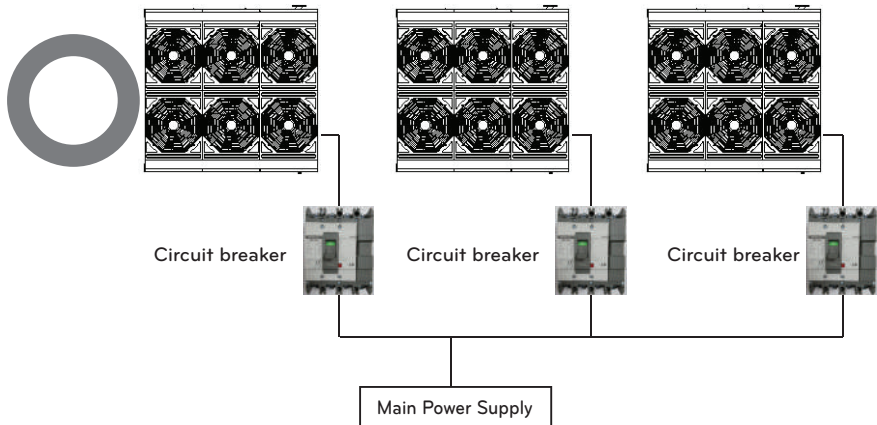

Incorrect installation

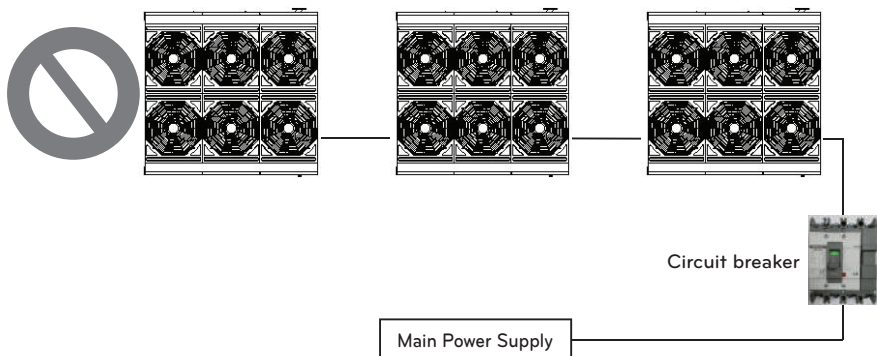

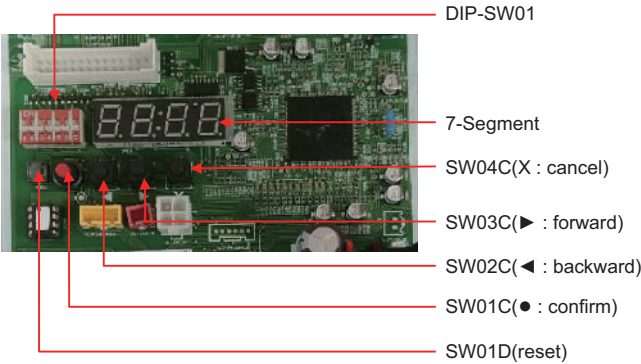

How to set control box address (Set cycle PCB address)

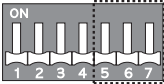

1 Select the address by turning the DIP switch #5, #6 and #7 on the top right corner of PCB ON/OFF.

* If there is only 1 cycle PCB connected to the main controller of the chiller, use the address #1 only and if there are 2 cycle PCBs, use only #1 and #2 to select the address.

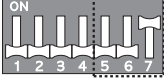
<p>Cycle address: 1 (DIP switch: #6, #7 OFF)</p>	<p>SW01B </p>
<p>Cycle address: 2 (DIP switch: #6 ON / #7 OFF)</p>	<p>SW01B </p>
<p>Cycle address: 3 (DIP switch: #7 ON / #6 OFF)</p>	<p>SW01B </p>

2 After selecting the cycle address with the DIP switch, always press the Reset button to complete the setting.

WARNING

- If there is only 1 cycle PCB connected to the main controller of the chiller, use the address #1 only and if there are 2 cycle PCBs, use only #1 and #2 to select the address. Or else the product will not operate.
- When replacing the cycle PCB of the control box, always run an automatic address setting again.
This must be performed with all cycle PCB and HMI PCB connected. If not, it will result in operation error.
- When setting the address, check and change other control box PCB address within the chiller. PCB address for replacement is set to 1. If control box PCB address is duplicated, the product will not operate.
Control box PCB address is set to 1, 2 and 3 in order as factory default.

How to install HMI indoors

! CAUTION

- HMI is designed to basically be installed and used on the wall.
- This example describes how to install HMI on the wall.
- If the wall is firm, prior work is required to drill the screws.
- Communication cable for indoor installation is not included in the components.
- It is recommended to use communication cable of 0.75 square or above.

Decide the space to install HMI. Before fixating the HMI, check whether it is an appropriate location to connect the communication cable and power cable to HMI.

Use the drier and M4 screw on the top wall of the communication cable to fixate the rear panel of HMI. It can be fixated as shown below depending on the installed location.

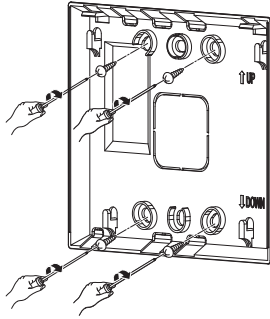

Pull out the communication cable through the hole on the rear side of the panel.

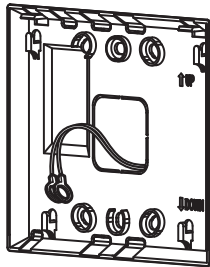

! CAUTION

- Because different polarities exist on the communication cable, make sure not to mix them.
- To prevent incorrect wiring, it is recommended to mark A and B on the communication cable.
- Use the ring or Y terminal for connecting to the control box terminal of the communication cable.
- Refer to page 16 "Internal configuration of control panel" for location of control box terminal.

Connect the socket to the communication port located on the rear side of the HMI.

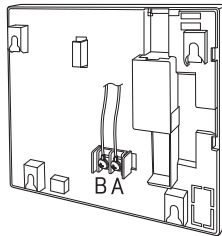

Connect the power adapter (Component) to the power terminal located on the rear side of the HMI.

Assemble the main unit of HMI to the rear panel installed on the wall. After hanging the hole of the top of the main unit to the top of the rear panel, push the bottom of the unit to assemble it.

Connect the power cord of the power adapter to the power plug.

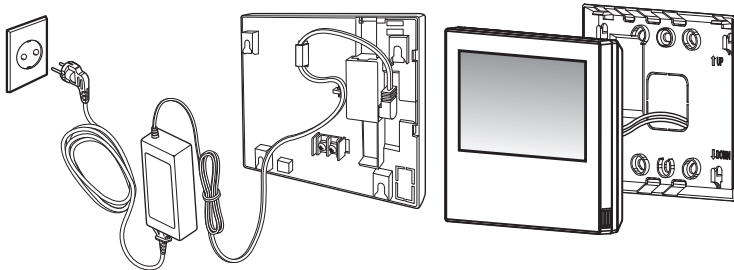

! CAUTION

If the power cord of power adapter and power cord must be buried due to short distance, it requires space of 120 mm x 80 mm x 80 mm to arrange the power adapter and power cord.

Unit Combination

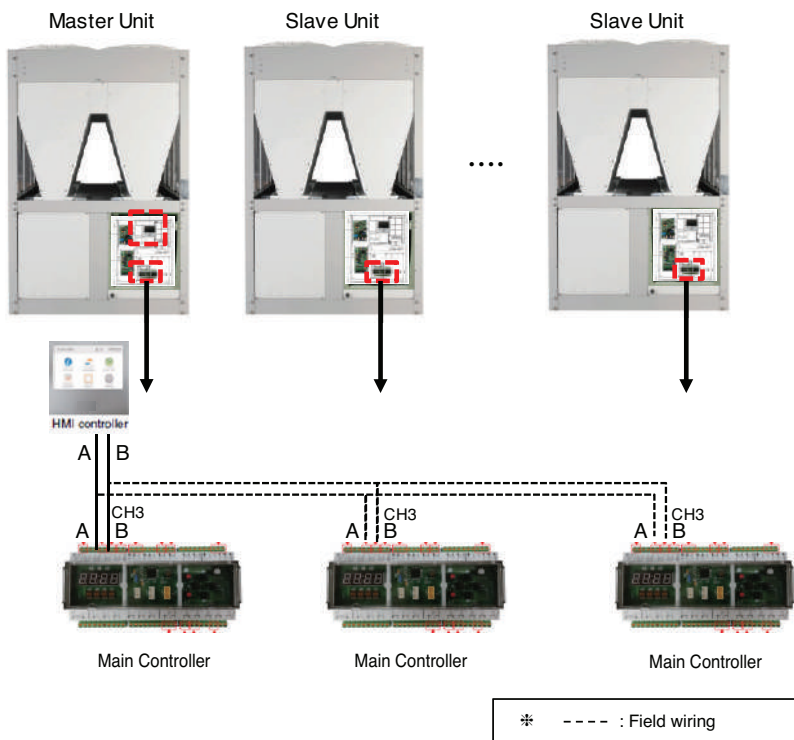

- 1 Communication line is divided A into B like a picture and is jump connected to Main Unit and Main Controller CH3 of Slave unit.
- 2 Communication line jump connected is divided A into B to HMI of Master Unit and in connect-ed.
- 3 Use 2-line shield as a communication line
- 4 Separately install the communication and power cable of the chiller so that communication cable is not affected by the electric noise generated from power cable(Do not pass though the same electric pipe)
- 5 Unit combination is able to connect up to 5 units.
- 6 When connecting the communication wire to the controller, use pin type JOB153 for the terminal of the wire.

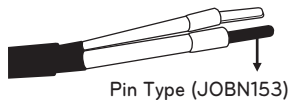

⚠ WARNING

- If number and address of product to want to interlock is not set from HMI, Error will occur.(please refer to control > freezer interlocking control about HMI address setting)
- If Main Controller address doesn't match HMI address, Error will occur. .(please refer to control > freezer address setting about Controller address setting)

How to set the main controller address

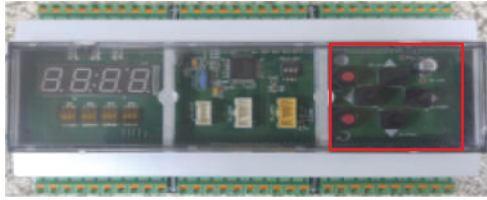

- 1 Press the down (▼) button and the right (▶) button at the same time for 5 seconds.
- 2 Press the up/down (▲▼) button to move to FN02.
- 3 Press the SW_CONF button.
- 4 Press the left and right (◀▶) buttons to set the Main Controller address.
- 5 It is set by pressing the SW_CONF button.
- 6 SW_BACK (red key) input

TEST RUN

Checkpoint before test run

Start the chiller after checking the following.

- Before starting the chiller, check the supplementary devices such as cold water circulation pump, AHU or other devices. Refer to the directions from the manufacturer. If all equipped parts are installed on the device, check whether all parts are installed appropriately and accurately and check whether the wiring is done correctly. Refer to the wiring diagram of the product.
- Check the flow switch for appropriate operation of the product. Check whether the sensor is operating properly.
- For cooling, fill up cold water circuit with clean water or other non-corrosive liquid and purge the air so that there is no air remaining inside the cold water circuit. If the outdoor temperature is expected to drop below 0°C, add anti-freeze additive to the cold water circuit to prevent the water from freezing. Cold water circuit must be cleaned before connecting to the product.
- When the outdoor temperature in winter falls below 5 °C, take measures to prevent freezing of water pipes
- Freeze protection measures such as antifreeze injection, heater operation, and pump operation are required.
- Check and inspect all water pipes. Check whether the direction of the water flowing is correct and whether properly connected to the evaporator. Open all flow valves to the evaporator side.
- Turn on the cold water pump and measure the overall water pressure reduction of evaporator to check whether the flow is accurate compared to the designed flow rate.
- Check all electric connections within the control panel and whether all parts are tightly assembled with good contact conditions. Though the connecting part is checked from the factory but it can be loosened during the transportation from the vibration.
- Check and inspect all fuses. All fuses within the power panel and control panel must be installed at appropriate location.

Starting procedure

The chiller can be started as follows.

- Check whether the load is operating on the air processing device or other device on the side of the water that supplies the water to the chiller. If the temperature of the cold water is too high, the start of the load device on the water side can be delayed.
- If auto control does not work from the chiller, check whether the water circulation pump is operating.
- Voltage variance must be within 10 % and check that the phase voltage imbalance does not exceed 5 % between phases. Check whether the power and capacity is appropriate for processing the load.
- Check the order of the power phase.
- Check and inspect the voltage monitoring meter within the power panel. The meter should not show any error code.
- Use the HMI device to check the cold water outlet temperature and cooling water output temperature setting.
- Set the start menu of HMI device to start the system. Water circulation flow must be within the permitted range to control the temperature appropriately.

Check during start

After the above procedure, start the chiller to check whether everything works normally. If there is any issue, immediately stop the product and follow the "Troubleshooting" process. Refer to the Appendix for the criteria of each detail.

Follow the below procedure for checkpoints when starting the chiller.

- Check the rotating direction of the condenser fan motor. Place newspaper or tissue to check whether the air flow is normal around the motor.
- Check whether the cold water outlet temperature is the same as the setting.
- Through HMI device, check whether all sensors show effective values. Temperature sensor detects the compressor discharge temperature, compressor suction temperature, condenser outlet temperature and cold water inlet/outlet temperature.
- Check whether the operating current, operating noise and vibration is the same as the product specification.

Stop

After completing to check based on the above procedure, stop the product.

After the above procedure, start the chiller to check whether everything works normally.

If there is any issue, immediately stop the product and follow the "Troubleshooting" process. Refer to the Appendix for the criteria of each detail.

Follow the below procedure for checkpoints when stopping the chiller.

- Press the stop button from HMI.
- Measure the stopping time of the actual product after pressing the stop button.
- Stop the cold water pump.

Load operation and operation adjustment

After starting and stopping the product, check the product function by operating the load and adjusting the operation.

Adjust the cold water outlet temperature setting to adjust the load to check the product while changing the operating condition.

Prepare operation data

Always record the operating condition when operating the chiller to check whether it is operating normally compared to the specification.

Refer to 'the standard operation record' page of Appendix.

Analyze water quality of cold water

Analyze the water quality during the test run and secure the data.

Compare the water quality analysis result after a certain period of time (monthly check is recommended) against that of test run to decide the period to change the water.

ADDITIONAL FUNCTION

DIP switch setting

The DIP switch setting of the control box for additional function is as shown below. Change the DIP switch setting of individual cycle control box PCB to select the functions in the following table.

Night low noise function

This function judges the hottest day time during the cooling operation to reduce the fan noise of the outdoor unit at night time with low cooling load by running the outdoor unit fan at low RPM.

How to set maximum RPM

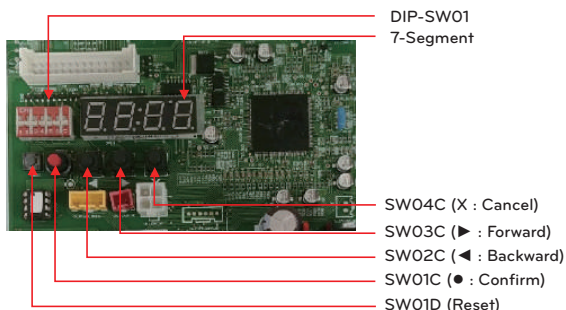

Cycle Main PCB DIP S/W No. 5 ON

Press the SW01D button until the Func is displayed.

Continue to press the SW01C button until the Fn3 is displayed + press SW01D button 1 time to set the step.

When Fn3 is on, press the SW10C or SW02C button until the applicable step is displayed.

① STEP 1-3Maximum RPM = 820

② STEP 4-6Maximum RPM = 750

③ STEP 7-8Maximum RPM = 720

※ Refer to right table for standby time/operating time by step

Start night low noise function (When setting step 1)

After maximum chiller temperature is detected, it operates at 820 (Set) RPM after 8 hours (Standby time)

Stop night low noise function (When setting step 1)

After running night low noise function, it is automatically canceled after 9 hours (Operation time)

RPM/Time setting

Step		Maximum fan RPM	Standby time (Hr)	Operation time (Hr)
1	①	820	8.0	9.0
2			6.5	10.5
3			5.0	12.0
4	②	750	8.0	9.0
5			6.5	10.5
6			5.0	12.0
7	③	720	8.0	9.0
8			6.5	10.5
9			5.0	12.0
10	-	820	0	Continuous operation
11		750	0	Continuous operation
12		720	0	Continuous operation

CAUTION

- Reset the main board of the cycle control box before running this function.
- Request the function setting to the installation expert after installing the chiller.
- If the function is not used, turn the DIP switch OFF and reset the power.
- If chiller RPM is changed, the cooling capacity may be reduced.

Inlet and outlet temperature difference setting mode

In the refrigeration cycle, the inlet and outlet temperature difference is $\Delta T = 5\text{ }^{\circ}\text{C}$. This value can be changed at the time of on-site installation. At this time, the flow rate should be reduced in inverse proportion to the changing inlet and outlet temperature difference. Flow S/W limit should be set on site when the flow rate decreases. The setting below is for $\Delta T = 10\text{ }^{\circ}\text{C}$

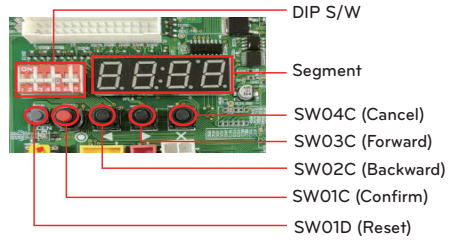

Mode on

- 1 Turn on Cycle Main PCB DIP S/W No. 5.



- 2 Check Func in the Segment window.



- 3 Press the SW03C button to set Fn07 in the Segment window.



- 4 Press the SW01C button to confirm Fn07.



Setup	Details	Flow rate change
oP1	$\Delta T = 8.5\text{ }^{\circ}\text{C}$	58% compared to $\Delta T = 5\text{ }^{\circ}\text{C}$
oP2	$\Delta T = 10\text{ }^{\circ}\text{C}$	50% compared to $\Delta T = 5\text{ }^{\circ}\text{C}$

- 5 Press the SW03C button to check oP2 in Segment window.



- 6 Press the SW01C button to confirm oP2.



- 7 Large temperature difference mode is turned on.

Mode off

- 1 Turn on Cycle Main PCB DIP S/W No. 5.



- 2 Check Func in the Segment window.



- 3 Press the SW03C button to set Fn07 in the Segment window.



- 4 Press the SW01C button to confirm Fn07.



- 5 Press the SW02C button to set OFF in the Segment window.



- 6 Press the SW01C button to confirm OFF.



- 7 Large temperature difference mode is turned off.

SELF DIAGNOSIS FUNCTION

Self diagnosis function

This function self diagnose the product and displays the error type.

Error is displayed in the popup window as shown below in HMI and if the error is resolved, press the "Reset" button on HMI to close the error window.



- OK button

This is the button to close the alarm popup window.

Alarm popup window is closed for user convenience from the screen but the current alarm status is maintained.

- Error code

Error code is configured as follows.

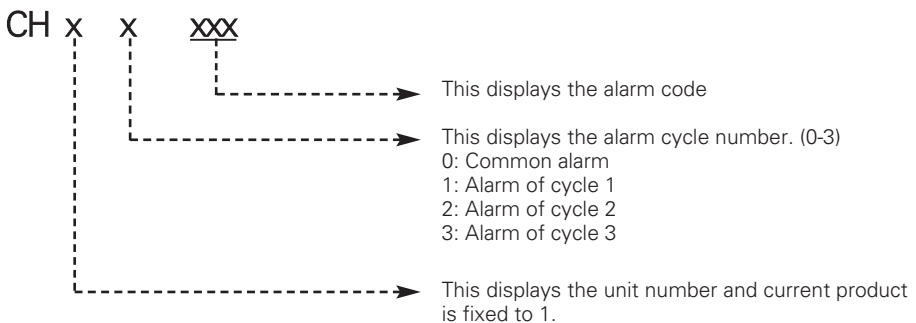

Process alarm (error)

- Common alarm (error)

CH10XXX error basically stops the product

- Alarm (Error) by cycle

When the alarm occurs by cycle, applicable cycle is maintained at stopped condition and normal cycles operate normally.

If the alarm from the cycle is canceled, it resumes normal operation.

**CAUTION**

When composed of 3 cycles, overall product condition maintains the operating condition even when 2 cycles are in error condition, and the overall product will stop only when all 3 cycles are in error condition.

WATER MANAGEMENT

Water pipe side strainer

For the protection of the water cooling type product, make sure to install strainer of 30 Mesh or more in the water side pipe.

Otherwise, heat exchanger may be damaged by the following conditions.

- 1 The water side in the plate type heat exchanger is formed by several small flow paths.
- 2 If strainer of 30 Mesh or more is not used, foreign object may block some flow paths.
- 3 As a result of the heat exchanger damage by freeze burst, the refrigerant is mixed with the water and the product becomes unusable.

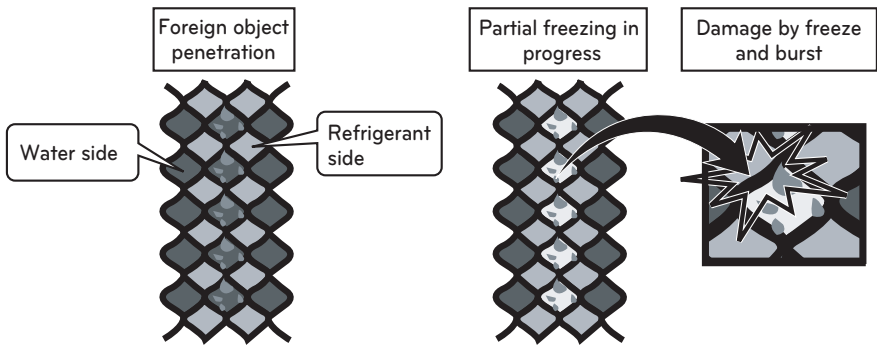

Actions for problems in the test operation

Category	Status	Cause	Inspection and Action
Whether water is supplied	CH 13	It is the error detected with regards to the water during the flow switch connection, and water does not flow, or flow amount is insufficient. (All operation conditions)	Check if water supply pump works.
			Check blocking of the water pipe. (Strainer cleaning, valve locked, valve problem, air in the pipe, etc.)
	CH 180	Water does not flow, or flow amount is insufficient.	Check flow switch problem. (Flow switch disorder, unauthorized handling, disconnection, etc.)
			Check if water supply pump works
			Check blocking of the water pipe. (Strainer cleaning, valve locked, valve problem, air in the pipe, etc.)

Plate type heat exchanger maintenance

As scale generation is accumulated, plate type heat exchanger efficiency may be decreased or damage may occur by freeze and burst with decreased flow amount.

For such reasons, it is necessary to have periodical management to prevent scale generation.

- 1 Before entering the usage season, check the following items. (Period: 1 time per year)
 - Perform water quality inspection to see if it is within the standard condition.
 - Perform strainer cleaning.
 - Check if the flow amount is adequate.
 - Check if operation environment is adequate. (Pressure, flow amount, water outlet temperature, etc.)
- 2 To clean the plate type heat exchanger, follow the procedures below. (Period: 1 time per year)
 - Check if service port is mounted on the water pipe for chemical solvent cleaning. 5% diluted formic acid, citric acid, oxalic acid(water acid), acetic acid, phosphoric acid, etc. are suitable as the chemical solvent for scale cleaning. (* Hydrochloric acid, sulfuric acid, nitric acid, etc. have corrosive property, so they may never be used.)
 - During the cleaning, make sure if water inlet and outlet pipe gate valve and drain pipe valve are properly locked.
 - Connect the pipe for chemical solvent cleaning through water pipe service plug, fill the cleaning solvent of about 50 °C ~ 60 °C in the plate type heat exchanger, and circulate with pump for about 2 ~ 5 hours. The circulation time may be different according to the cleaning solvent temperature or amount of scale. Therefore, closely observe the chemical solvent color changes to decide the circulation time for scale removal.
 - After the solvent circulation work, completely drain the chemical solvent in the plate type heat exchanger, fill 1~2 % concentration sodium hydroxide (NaOH) or hydrocarbon sodium (NaHCO_3) and circulate for about, 15~20 min. to neutralize the heat exchanger.
 - After the neutralization work is completed, clean inside the plate type heat exchanger with clean water. By measuring the pH concentration of the water, you can verify if the chemical solvent is properly removed.
 - If you use other type of chemical solvent in the market, make sure to check if there is any corrosive property against stainless or copper in advance.
 - Receive consultation from the experts in the relevant industry for details of cleaning chemical solvent.
- 3 After cleaning work is completed, operate the product to see if it works properly once again.

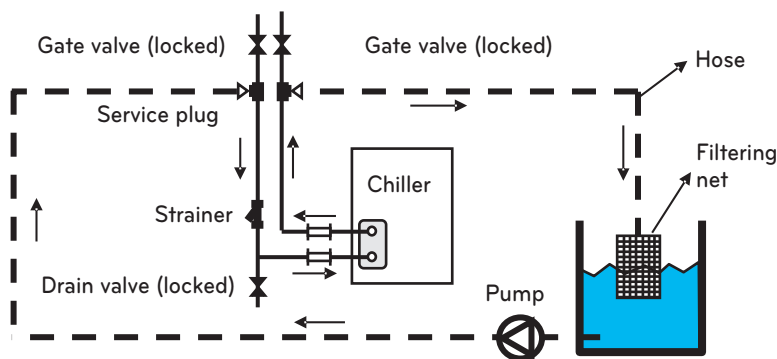

[Plate type heat exchanger cleaning]



CAUTION

- The above inspection table sets the minimum period, and more frequent inspections are necessary according to installation environment, operation condition / water quality condition.
- During the heat exchanger cleaning, you have to take off the parts such as pressure gauge or lock the valve so that chemical solvent may not enter.
- During the cleaning, check the pipe connection parts in advance to prevent leakage of the chemical solvent.
- Start the cleaning work after the chemical solvent and water are sufficiently mixed.
- It is better to perform the heat exchanger cleaning work in the early stage, and when the scale accumulation becomes severe, it becomes difficult to remove them.
- In the region with poor water quality, periodical cleaning works are necessary.
- Chemical solvent has strong acidic property, so it shall be completely washed with water.
- To verify if the inside became clean, remove the hose and check inside the pipe.
- Make sure to perform the air purge to remove air inside water pipe.
- After the inspection, make sure to check if the water properly flows before restarting the product.

TROUBLESHOOTING

General error



CAUTION

If the product stopped from the safety device, identify and resolve the root cause before restarting.

Before introducing the special warning, this introduces the general issues and how to troubleshoot the issues.

When the chiller is not operating, check the power, refrigerant, configuration and alarm setting of the chiller.

Check the voltage connected to the terminal block inside the power panel to check the power.

If there is no power, check whether the power circuit breaker is down.

If the power is properly connected, check the cycle pressure of the chiller to check whether it is within the normal range.

If the pressure exceeds the normal range, check for leakage by using the soap bubble.

Before starting the chiller, return to the default setting.

Lastly check the alarm setting. Alarm can be checked through the HMI device.

If the alarm is turned on, follow the troubleshooting method for specific alarm.

Symptom	Potential cause	Potential solution
Device does not start.	Check power of the device	Check over-current protection device Check if fuse is disconnected Resume power to device
	Incorrect or inaccurate device configuration	Check device configuration Check if wiring is incorrect
	Alarm is on	Check alarm condition Check for separate alarm troubleshooting process and resolve the issue Follow the direction Check the HMI input channel to check the alarm condition input
	Entering delay time	Check whether compressor entered start delay time

Symptom	Potential cause	Potential solution
Evaporation pressure is low and the product constantly stops.	Insufficient refrigerant	Check for leakage and refill refrigerant
	Insufficient cold water	Check cold water system (Ensure rated flow) - Is the valve of cold water system closed? - Is the pressure difference between inlet and outlet of cold water system appropriate? - Is the air of cold water system cold?
Condensation pressure is high and the product constantly stops.	Outdoor temperature is high	Check whether outdoor temperature is within operating range
	Alien particles accumulated on the condenser	Clean condenser
	Fan defect	Replace fan
Product vibrates loudly.	Fan-motor connecting bolt is loose	Check assembly condition and tighten bolt
	Motor-mount motor assembly is loose	Check assembly condition and tighten bolt
	Fan is not balanced	After checking fan rotation range, replace fan
	Compressor assembly bolt is loose	If the assembly bolt/nut is loose, tighten it.
	Frame assembly bolt is loose	Check assembly condition and tighten bolt
	Motor bearing is burnt	Check for abnormal noise in motor (Noise in multiple of RPM) and replace motor
Resonance sound	Rubber fixed condition of motor mount is defective	Replace motor mount
	Pipe vibration defect around compressor	Replace anti-vibration rubber attached on pipe
High frequency wave noise from front side of product	Defect in heat emitting fan in control box	Clean part around heat emitting fan
Constantly hunting for cold water temperature	Insufficient cold water	Check cold water system (Ensure rated flow) - Is the valve of cold water system closed? - Is the pressure difference between inlet and outlet of cold water system appropriate? - Is the air of cold water system cold? - Is the cooling load within appropriate range?
Evaporation pressure is high	Temporary rise in cold water temperature due to abnormal increase in load	It is not abnormal. But, check if it is within operating range.

Alarm

The description of the alarm is as follows.

Error code	Error name	
	Error condition	
	Control during error	Release condition
CHxx001	Outdoor temperature sensor error	
	Outdoor temperature sensor is open/short	
	Stop product	Automatically return to normal condition
CHxx003	HMI communication error	
	When communication between HMI and chiller controller is disconnected for more than 30 seconds	
	Stop product	Automatically return to normal condition
CHxx005	Cycle control box communication error	
	When communication between chiller controller and cycle control box is disconnected for more than 30 seconds	
	Stop product	Automatically return to normal condition
CHxx009	Remote communication error	
	When the modbus communication with the external device is not established for more than 30 seconds after the initial communication with the remote modbus condition is established	
	Stop product	Automatically return to normal condition
CHxx011	Load water pump interlock error	
	When the load water pump is turned off for 3 seconds when starting or during the operation for more than 3 times within 1 hour When turned off more than 9 seconds within 1 hour	
	Stop product	Press the HMI Reset button
CHxx013	Load water flow switch error	
	When the load water flow switch is turned off for 3 seconds when starting or during the operation for more than 3 times within 1 hour When turned off more than 9 seconds within 1 hour	
	Stop product	Press the HMI Reset button
CHxx015	Remote alarm	
	When the contact point signal of hardware wiring is short when entering the remote control mode	
	Stop product	Automatically return to normal condition

Error code	Error name	
	Error condition	
	Control during error	Release condition
CHxx021	Inverter compressor IPM fault	
	Inverter compressor drive IPM defect/Inverter compressor defect	
	Stop applicable cycle	Automatically return to normal condition
CHxx022	Inverter compressor input over-current	
	Inverter compressor input over-current	
	Stop applicable cycle	Automatically return to normal condition
CHxx023	Inverter compressor DC link low pressure	
	DC voltage charge defect	
	Stop applicable cycle	Automatically return to normal condition
CHxx024	Cycle high pressure switch operation	
	High pressure switch operates due to abnormal high pressure	
	Stop applicable cycle	Automatically return to normal condition
CHxx025	High/Low voltage of input voltage	
	Over/Under permitted voltage of input voltage, N	
	Stop applicable cycle	Automatically return to normal condition
CHxx026	Inverter compressor start failure error	
	Initial start failure from compressor defect	
	Stop applicable cycle	Automatically return to normal condition
CHxx028	Inverter DC link high voltage error	
	Defect from DC voltage and over-charge	
	Stop applicable cycle	Automatically return to normal condition
CHxx029	Inverter compressor over-current	
	Exceed limit	
	Stop applicable cycle	Automatically return to normal condition

Error code	Error name	
	Error condition	
	Control during error	Release condition
CHxx032	Surge in inverter #1,#2 compressor discharge temperature	
	Stop applicable cycle	Automatically return to normal condition
CHxx034	Surge in high pressure	
	Surge in high pressure side	
	Stop applicable cycle	Automatically return to normal condition
CHxx035	Surge in low pressure	
	Drop in low pressure side	
	Stop applicable cycle	Automatically return to normal condition
CHxx036	Low compression rate error	
	Low compression rate error	
	Stop applicable cycle	Automatically return to normal condition
CHxx040	Inverter compressor CT sensor error	
	Inverter compressor CT sensor is short/open	
	Stop applicable cycle	Automatically return to normal condition
CHxx041	Inverter compressor discharge temperature sensor error	
	Inverter compressor discharge temperature sensor is short/open	
	Stop applicable cycle	Automatically return to normal condition

Error code	Error name	
	Error condition	
	Control during error	Release condition
CHxx042	Low pressure sensor error	
	Low pressure sensor is short/open	
	Stop applicable cycle	Automatically return to normal condition
CHxx043	High pressure sensor error	
	High pressure sensor is short/open	
	Stop applicable cycle	Automatically return to normal condition
CHxx045	Heat exchanger temperature sensor error	
	Heat exchanger temperature sensor is short/open	
	Stop applicable cycle	Automatically return to normal condition
CHxx046	Suction temperature sensor error	
	Suction temperature sensor is short/open	
	Stop applicable cycle	Automatically return to normal condition
CHxx049	IPM temperature sensor error	
	IPM temperature sensor Short/Open	
	Stop applicable cycle	Automatically return to normal condition
CHxx050	Chiller 3 phase power missing phase	
	Chiller 3 phase power missing phase	
	Stop applicable cycle	Automatically return to normal condition

Error code	Error name	
	Error condition	
	Control during error	Release condition
CHxx052	Communication error with inverter controller	
	Communication error with inverter controller	
	Stop applicable cycle	Automatically return to normal condition
CHxx057	Communication error with inverter controller	
	Communication error with inverter controller	
	Stop applicable cycle	Automatically return to normal condition
CHxx059	Installation Failure of Series Model Outdoor Unit	
	Installation Failure of Series Model Outdoor Unit	
	Stop applicable cycle	Automatically return to normal condition
CHxx060	Inverter PCB EEPROM error	
	Inverter PCB EEPROM error	
	Stop applicable cycle	Automatically return to normal condition
CHxx062	Surge in inverter board IPM temperature	
	Surge in inverter board IPM temperature	
	Correspond cycle stop	Automatic return to a normal condition
CHxx065	Inverter IPM temperature sensor error	
	Inverter IPM temperature sensor is short/open	
	Stop applicable cycle	Automatically return to normal condition
CHxx067	Fan lock	
	Fan locked	
	Stop applicable cycle	Automatically return to normal condition

Error code	Error name	
	Error condition	
	Control during error	Release condition
CHxx075	Fan CT sensor error	
	Fan CT sensor is short/open	
	Stop applicable cycle	Automatically return to normal condition
CHxx076	FAN DC link high voltage error	
	FAN DC LINK HIGH VOLTAGE FAULT	
	Stop applicable cycle	Automatically return to normal condition
CHxx077	Fan over-voltage error	
	Fan over-voltage	
	Stop applicable cycle	Automatically return to normal condition
CHxx079	Fan start failure error	
	Fan start failure	
	Stop applicable cycle	Automatically return to normal condition
CHxx086	Main PCB EEPROM error	
	Main PCB EEPROM access error	
	Stop applicable cycle	Automatically return to normal condition
CHxx087	Fan PCB EEPROM error	
	Fan PCB EEPROM access error	
	Stop applicable cycle	Automatically return to normal condition

Error code	Error name	
	Error condition	
	Control during error	Release condition
CHxx090	Individual Inletwater temperature sensor error	
	Individual Inletwater temperature sensor is short/open	
	Stop applicable cycle	Automatically return to normal condition
CHxx091	Individual Outletwater temperature sensor error	
	Individual Outletwater temperature sensor is short/open	
	Stop applicable cycle	Automatically return to normal condition
CHxx104	Communication Error between Outdoor Unit	
	Communication Error between Outdoor Unit	
	Stop applicable cycle	Automatically return to normal condition
CHxx105	Fan board communication error	
	Fan board communication error	
	Stop applicable cycle	Automatically return to normal condition
CHxx106	Fan PCB IPM fault	
	Fan PCB IPM fault	
	Stop applicable cycle	Automatically return to normal condition
CHxx107	FAN DC link low/high voltage error	
	FAN DC link low/high voltage	
	Stop applicable cycle	Automatically return to normal condition
CHxx113	Liquid pipe temperature sensor error	
	Liquid temperature sensor is short/open	
	Stop applicable cycle	Automatically return to normal condition
CHxx114	Sub cooling Suction temperature sensor error	
	Sub cooling Suction temperature sensor Short/Open	
	Stop applicable cycle	Automatically return to normal condition
CHxx115	Sub cooling outlet pipe temperature sensor error	
	Sub cooling outlet pipe temperature sensor Short/Open	
	Correspond cycle stop	Automatic return to a normal condition

Error code	Error name	
	Error condition	
	Control during error	Release condition
CHxx145	Main Board - External Board communication Error	
	Main Board - External Board communication Error	
	Stop applicable cycle	Automatically return to normal condition
CHxx150	Liquid Compression Prevention Error	
	Liquid Compression Prevention Error	
	Stop applicable cycle	Automatically return to normal condition
CHxx151	Reversing valve switching failed	
	Mode switching failed	
	Stop applicable cycle	Automatically return to normal condition
CHxx180	Plate type heat exchanger frozen	
	When the load outlet water temperature is maintained at 2 °C or below after the compressor started or if the low pressure is maintained at less than 660 kPA after the compressor started	
	Stop applicable cycle	Automatically return to normal condition
CHxx193	Surge in fan board heat emitting plate temperature	
	Surge in fan board heat sink temperature	
	Stop applicable cycle	Automatically return to normal condition
CHxx194	Fan board heat emitting plate temperature sensor error	
	Fan board heat emitting plate temperature sensor is short/open	
	Stop applicable cycle	Automatically return to normal condition

APPENDIX

External diagram

- Model : 1 Unit

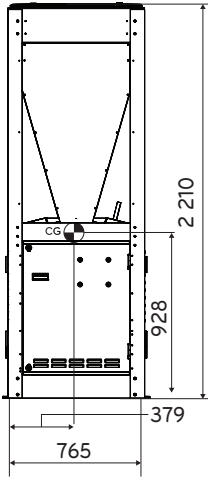

Front view

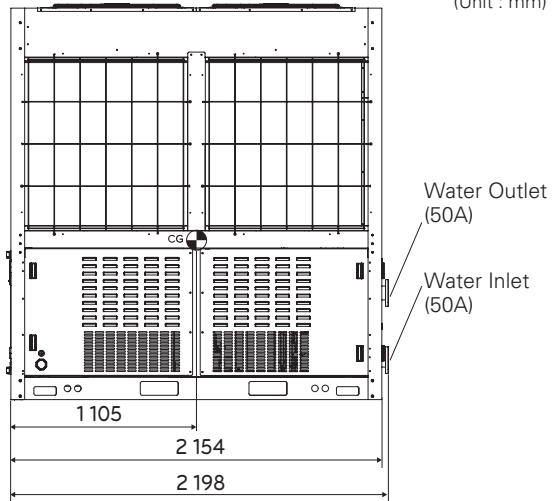

Side view

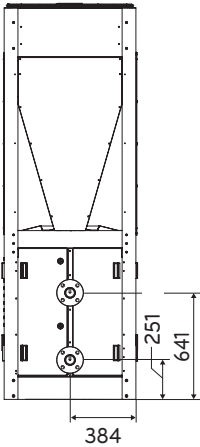

Rear view

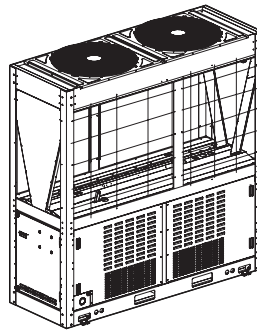

- Model : 2 UNIT

(Unit : mm)

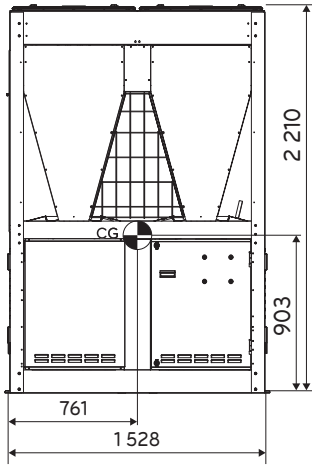

Front view

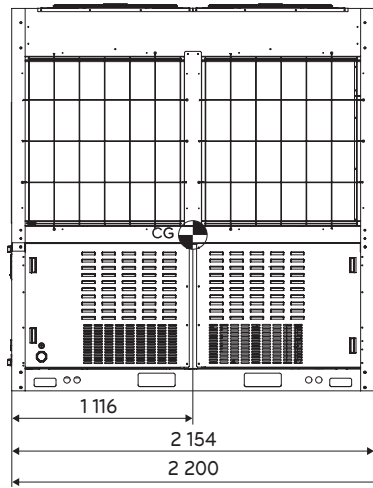

Side view

Water Outlet (65A)

Water Inlet (65A)

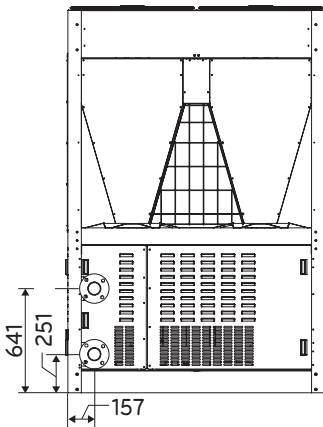

Rear view

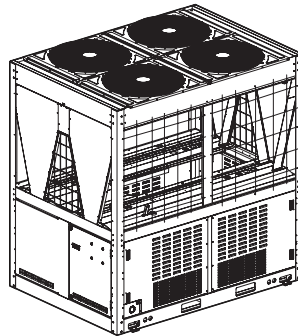

- Model : 3 UNIT

(Unit : mm)

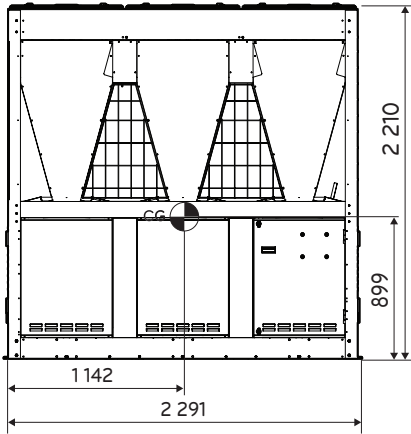

Front view

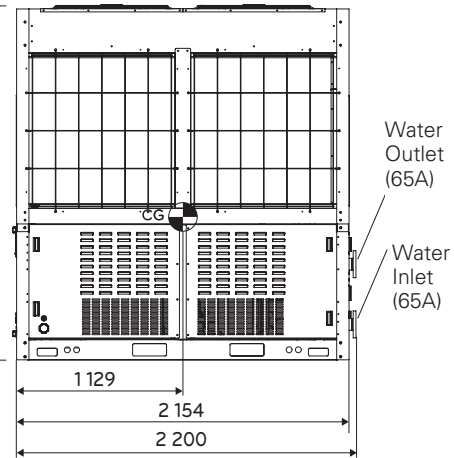

Side view

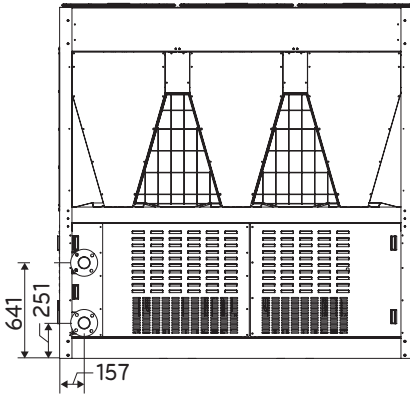

Rear view

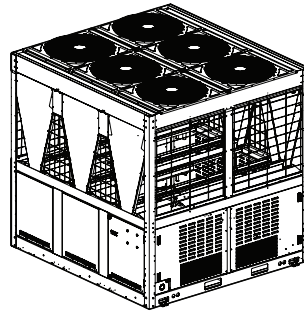

Power cable connection and wiring

Connect R, S, T, of the power cable separately to the circuit breaker in case of 1Unit or to Main terminal block in case of 2Unit or 3Unit.

1 Unit

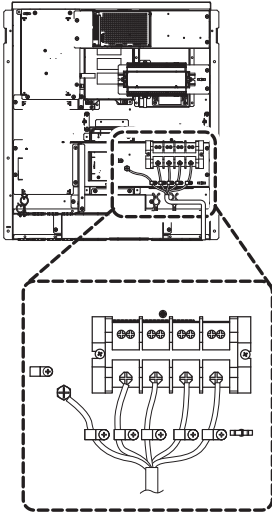

2 Unit

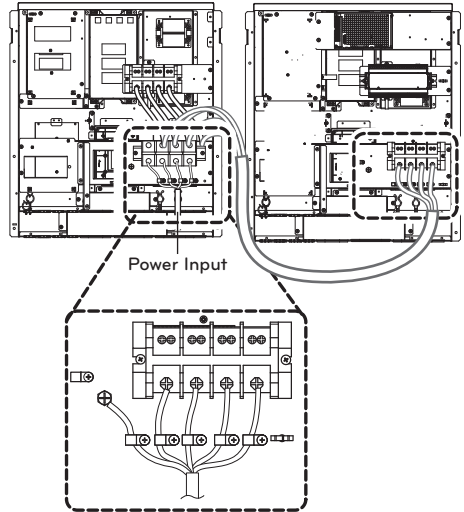

3 Unit

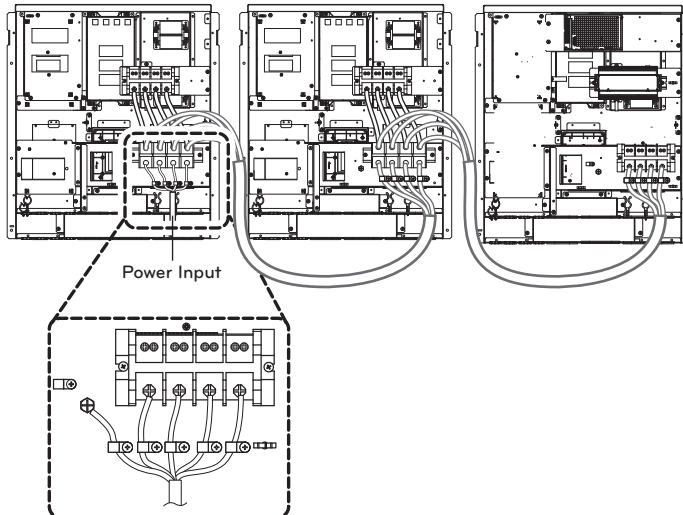



CAUTION

If the product enters the modbus remote mode, all the information can only be monitored via HMI, and the actual operation of starting/stopping or changing the set temperature can only be done through the external controller.

To make changes to control from HMI, change the control mode to "Local".



CAUTION

CH10009 remote communication error will occur when the communication is disconnected between the two controllers. When the communication is recovered, it will automatically resume. If the remote modbus connection is not used, reset the power of the main PCB of the unit to cancel the alarm.

Head loss curve

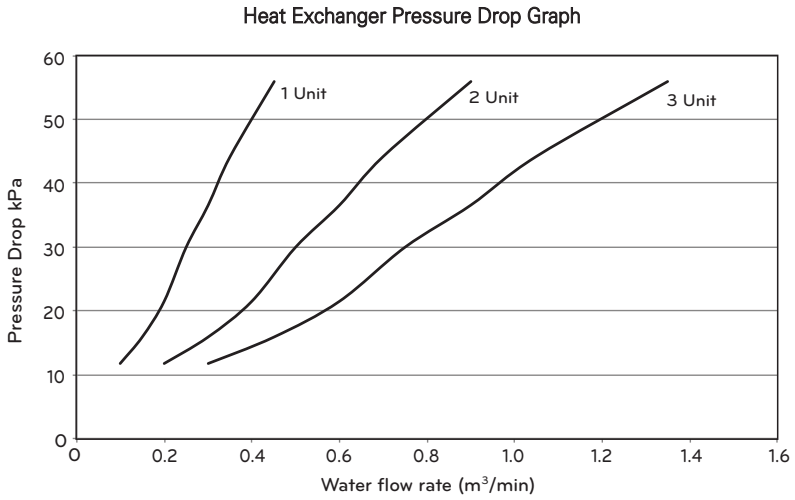

Modbus protocol

Coil Register

Register address	Description
1	0: Product stop, 1: Operation start
2	0: Alarm clear command Off
	1: Alarm clear command On
3	0: Status quo, 1: Delete accumulated operating time
4	0 : max frequency, 1 : Demand Limit
13	0: Flow sensor disused, 1: Flow sensor Used
14	(Flow Rate Unit) 0 : GPM, 1: LPM
15	(Pressure Unit) 0: kPa, 1: psi

Discrete Register

Register address	Description
10002	0 : Load Water Flow Switch Off
	1 : Load Water Flow Switch On
10004	0 : Load Water Pump Output Off
	1 : Load Water Pump Output On
10006	0: Load Water Pump Interworking Output Off
	1: Load Water Pump Interworking Output On
10105	0 : 4Way Valve Off of Cycle 1 (Left)
	1 : 4Way Valve On of Cycle 1 (Left)
10106	0 : 4Way Valve Off of Cycle 1 (Right)
	1 : 4Way Valve On of Cycle 1 (Right)
10107	0 : Hot gas Off of Cycle 1 (Left)
	1 : Hot gas On of Cycle 1 (Left)
10108	0 : Hot gas Off of Cycle 1 (Right)
	1 : Hot gas On of Cycle 1 (Right)
10109	0 : Sump Heater Off of Cycle 1 (Left)
	1 : Sump Heater On of Cycle 1 (Left)
10110	0 : Sump Heater Off of Cycle 1 (Right)
	1 : Sump Heater On of Cycle 1 (Right)

Register address	Description
10119	0 : Inverter Compressor Off of Cycle 1 (Left)
	1 : Inverter Compressor On of Cycle 1 (Left)
10120	0 : Inverter Compressor Off of Cycle 1 (Right)
	1 : Inverter Compressor On of Cycle 1 (Right)
10209	0 : 4Way Valve Off of Cycle 2 (Left)
	1 : 4Way Valve On of Cycle 2 (Left)
10210	0 : 4Way Valve Off of Cycle 2 (Right)
	1 : 4Way Valve On of Cycle 2 (Right)
10211	0 : Hot gas Off of Cycle 2 (Left)
	1 : Hot gas On of Cycle 2 (Left)
10212	0 : Hot gas Off of Cycle 2 (Right)
	1 : Hot gas On of Cycle 2 (Right)
10213	0 : Sump Heater Off of Cycle 2 (Left)
	1 : Sump Heater On of Cycle 2 (Left)
10214	0 : Sump Heater Off of Cycle 2 (Right)
	1 : Sump Heater On of Cycle 2 (Right)
10223	0 : Inverter Compressor Off of Cycle 2 (Left)
	1 : Inverter Compressor On of Cycle 2 (Left)
10224	0 : Inverter Compressor Off of Cycle 2 (Right)
	1 : Inverter Compressor On of Cycle 2 (Right)
10313	0 : 4Way Valve Off of Cycle 3 (Left)
	1 : 4Way Valve On of Cycle 3 (Left)
10314	0 : 4Way Valve Off of Cycle 3 (Right)
	1 : 4Way Valve On of Cycle 3 (Right)
10315	0 : Hot gas Off of Cycle 3 (Left)
	1 : Hot gas On of Cycle 3 (Left)
10316	0 : Hot gas Off of Cycle 3 (Right)
	1 : Hot gas On of Cycle 3 (Right)
10317	0 : Sump Heater Off of Cycle 3 (Left)
	1 : Sump Heater On of Cycle 3 (Left)
10318	0 : Sump Heater Off of Cycle 3 (Right)
	1 : Sump Heater On of Cycle 3 (Right)
10327	0 : Inverter Compressor Off of Cycle 3 (Left)
	1 : Inverter Compressor On of Cycle 3 (Left)
10328	0 : Inverter Compressor Off of Cycle 3 (Right)
	1 : Inverter Compressor On of Cycle 3 (Right)

Input Register

Register address	Description
30001	Chiller Controller Version
30002	Entire Operation Current
30003	External Air Temperature
30004	Common Load Water Output Temperature (Average Value of Individual Load Water Outputs)
30005	Common Load Water Input Temperature (Average Value of Individual Load Water Inputs)
30008	Information of Refrigerator Failure (1~5)
30009	Cycle Failure Information (0 : Common System Error, 1~10 : Error of Corresponding Cycle)
30010	Failure Code
30011	Start Waiting Time
30013	Product's Accumulated Operation Time Upper Level
30014	Product's Accumulated Operation Time Lower Level
30015	Variable flow rate information supplied by the load water pump
30017	External Load Inlet Water Temperature
30018	External Load outlet Water Temperature
30019	Flow Rate Sensor
30101, 30102	Load Water Output Temperature of Cycle 1
30103, 30104	Load Water Input Temperature of Cycle 1
30109	Condensation Temperature (Left) of Cycle 1
30110	Condensation Temperature (Right) of Cycle 1
30111	Evaporation Temperature (Left) of Cycle 1
30112	Evaporation Temperature (Right) of Cycle 1
30113	Inverter Compressor (Left) Frequency of Cycle 1
30114	Inverter Compressor (Right) Frequency of Cycle 1
30115	High Pressure (Left) of Cycle 1
30116	High Pressure (Right) of Cycle 1
30117	Low Pressure (Left) of Cycle 1
30118	Low Pressure (Right) of Cycle 1
30119	Operation Current (Left) of Cycle 1
30120	Operation Current (Right) of Cycle 1

Register address	Description
30121	Main EEV (Left)'s Status Value of Cycle 1 (Cooling)
30122	Main EEV (Right)'s Status Value of Cycle 1 (Cooling)
30123	Sub EEV (Left)'s Status Value of Cycle 1 (Heating)
30124	Sub EEV (Right)'s Status Value of Cycle 1 (Heating)
30125	Discharge Temperature of Inverter Compressor (Left) of Cycle 1
30126	Discharge Temperature of Inverter Compressor (Right) of Cycle 1
30127	Intake Temperature of Inverter Compressor (Left) of Cycle 1
30128	Intake Temperature of Inverter Compressor (Right) of Cycle 1
30129	Liquid Pipe Temperature (Left) of Cycle 1
30130	Liquid Pipe Temperature (Right) of Cycle 1
30131	Hex Temperature (Left) of Cycle 1
30132	Hex Temperature (Right) of Cycle 1
30145	Accumulated Operation Time of Inverter Compressor (Left) of Cycle 1 (Upper Level)
30146	Accumulated Operation Time of Inverter Compressor (Left) of Cycle 1 (Lower Level)
30147	Accumulated Operation Time of Inverter Compressor (Right) of Cycle 1 (Upper Level)
30148	Accumulated Operation Time of Inverter Compressor (Right) of Cycle 1 (Lower Level)
30201, 30202	Load Water Output Temperature of Cycle 2
30203, 30204	Load Water Input Temperature of Cycle 2
30209	Condensation Temperature (Left) of Cycle 2
30210	Condensation Temperature (Right) of Cycle 2
30211	Evaporation Temperature (Left) of Cycle 2
30212	Evaporation Temperature (Right) of Cycle 2
30213	Inverter Compressor (Left) Frequency of Cycle 2
30214	Inverter Compressor (Right) Frequency of Cycle 2
30215	High Pressure (Left) of Cycle 2
30216	High Pressure (Right) of Cycle 2
30217	Low Pressure (Left) of Cycle 2
30218	Low Pressure (Right) of Cycle 2
30219	Operation Current (Left) of Cycle 2
30220	Operation Current (Right) of Cycle 2

Register address	Description
30221	Main EEV (Left)'s Status Value of Cycle 2 (Cooling)
30222	Main EEV (Right)'s Status Value of Cycle 2 (Cooling)
30223	Sub EEV (Left)'s Status Value of Cycle 2 (Heating)
30224	Sub EEV (Right)'s Status Value of Cycle 2 (Heating)
30225	Discharge Temperature of Inverter Compressor (Left) of Cycle 2
30226	Discharge Temperature of Inverter Compressor (Right) of Cycle 2
30227	Intake Temperature of Inverter Compressor (Left) of Cycle 2
30228	Intake Temperature of Inverter Compressor (Right) of Cycle 2
30229	Liquid Pipe Temperature (Left) of Cycle 2
30230	Liquid Pipe Temperature (Right) of Cycle 2
30231	Hex Temperature (Left) of Cycle 2
30232	Hex Temperature (Right) of Cycle 2
30245	Accumulated Operation Time of Inverter Compressor (Left) of Cycle 2 (Upper Level)
30246	Accumulated Operation Time of Inverter Compressor (Left) of Cycle 2 (Lower Level)
30247	Accumulated Operation Time of Inverter Compressor (Right) of Cycle 2 (Upper Level)
30248	Accumulated Operation Time of Inverter Compressor (Right) of Cycle 2 (Lower Level)
30301, 30302	Load Water Output Temperature of Cycle 3
30303, 30304	Load Water Input Temperature of Cycle 3
30309	Condensation Temperature (Left) of Cycle 3
30310	Condensation Temperature (Right) of Cycle 3
30311	Evaporation Temperature (Left) of Cycle 3
30312	Evaporation Temperature (Right) of Cycle 3
30313	Inverter Compressor (Left) Frequency of Cycle 3
30314	Inverter Compressor (Right) Frequency of Cycle 3
30315	High Pressure (Left) of Cycle 3
30316	High Pressure (Right) of Cycle 3
30317	Low Pressure (Left) of Cycle 3
30318	Low Pressure (Right) of Cycle 3
30319	Operation Current (Left) of Cycle 3
30320	Operation Current (Right) of Cycle 3

Register address	Description
30321	Main EEV (Left)'s Status Value of Cycle 3 (Cooling)
30322	Main EEV (Right)'s Status Value of Cycle 3 (Cooling)
30323	Sub EEV (Left)'s Status Value of Cycle 3 (Heating)
30324	Sub EEV (Right)'s Status Value of Cycle 3 (Heating)
30325	Discharge Temperature of Inverter Compressor (Left) of Cycle 3
30326	Discharge Temperature of Inverter Compressor (Right) of Cycle 3
30327	Intake Temperature of Inverter Compressor (Left) of Cycle 3
30328	Intake Temperature of Inverter Compressor (Right) of Cycle 3
30329	Liquid Pipe Temperature (Left) of Cycle 3
30330	Liquid Pipe Temperature (Right) of Cycle 3
30331	Hex Temperature (Left) of Cycle 3
30332	Hex Temperature (Right) of Cycle 3
30345	Accumulated Operation Time of Inverter Compressor (Left) of Cycle 3 (Upper Level)
30346	Accumulated Operation Time of Inverter Compressor (Left) of Cycle 3 (Lower Level)
30347	Accumulated Operation Time of Inverter Compressor (Right) of Cycle 3 (Upper Level)
30348	Accumulated Operation Time of Inverter Compressor (Right) of Cycle 3 (Lower Level)
39998	Product Group Info.
39999	Product Type Info.

Holding Register

Register Address	Register
40002	Operation Mode Setting (0 : Cooling)
40003	Cooling target temperature setting - R32 Refrigerant : Normal: 4 ~ 25 °C Low temperature: -10 ~ 25 °C
40004	Heating target temperature setting - R32 Refrigerant : 30~60 °C
40005	Control Mode Setting (On-site/Remote/Scheduled)
40006	Remote Mode Setting (Contact /Modbus)
40007	Cooling Type Setting (0 : Normal)
40008	Max. Operating Frequency Setting (0 : 120, 1 : 130, 2 : 110, 3 : 100, 4 : 90, 5 : 80, 6 : 70)
40011	Cooling spray condensation temperature setting (40.0 °C ~ 60.0 °C) [Default : 48.0 °C]
40012	Cooling spray ambient air temperature setting (20.0 °C ~ 60.0 °C) [Default : 35.0 °C]
40014	Start Delay Time Setting Range: 0 to 600 seconds [Default : 180]
40015	Flow Check Time Setting Range: 0 to 200 seconds [Default : 120]
40016	Pump Stop Delay Time Setting Range: 0 to 200 seconds [Default : 10]
40021	Common water outlet temperature offset correction value
40022	Thermo On Hysteresis Interval Temperature correction value setting
40023	Minimum entering water temperature value. (External sensor)
40024	Maximum entering water temperature value. (External sensor)
40025	Minimum leaving water temperature value. (External sensor)
40026	Maximum leaving water temperature value. (External sensor)
40027	Minimum measurable flow (GPM)
40028	Maximum measurable flow (GPM)

- Remote desired temperature contact point table

1. Chilled Water Set Point (2 ~ 10 V, 4 ~ 20 mA) : UI7 (Mode Cool)

Volt [V]	500Ω [mA]	Cool Set Point (-10 ~ 25) [°C]	Cool Set Point (14 ~ 77) [°F]	Etc
0.0	0.0	No Control (Disconnected)	No Control (Disconnected)	
0.2	0.4			
0.4	0.8			
0.6	1.2			
0.8	1.6			
1.0	2.0			
1.2	2.4			
1.4	2.8			
1.6	3.2			
1.8	3.6			
3.0	6.0	-10	14	(Low Temp. Type)
3.2	6.4	-9	15.8	(Low Temp. Type)
3.4	6.8	-8	17.6	(Low Temp. Type)
3.6	7.2	-7	19.4	(Low Temp. Type)
3.8	7.6	-6	21.2	(Low Temp. Type)
4.0	8.0	-5	23	(Low Temp. Type)
4.2	8.4	-4	24.8	(Low Temp. Type)
4.4	8.8	-3	26.6	(Low Temp. Type)
4.6	9.2	-2	28.4	(Low Temp. Type)
4.8	9.6	-1	30.2	(Low Temp. Type)
5.0	10.0	0	32	(Low Temp. Type)
5.2	10.4	1	33.8	(Low Temp. Type)
5.4	10.8	2	35.6	(Low Temp. Type)
5.6	11.2	3	37.4	(Low Temp. Type)
5.8	11.6	4	39.2	
6.0	12.0	5	41	
6.2	12.4	6	42.8	
6.4	12.8	7	44.6	
6.6	13.2	8	46.4	
6.8	13.6	9	48.2	
7.0	14.0	10	50	
7.2	14.4	11	51.8	
7.4	14.8	12	53.6	
7.6	15.2	13	55.4	
7.8	15.6	14	57.2	
8.0	16.0	15	59	
8.2	16.4	16	60.8	
8.4	16.8	17	62.6	
8.6	17.2	18	64.4	
8.8	17.6	19	66.2	
9.0	18.0	20	68	
9.2	18.4	21	69.8	
9.4	18.8	22	71.6	
9.6	19.2	23	73.4	
9.8	19.6	24	75.2	
10	20	25	77	

2. Hot Water Set Point (2 ~ 10 V, 4 ~ 20 mA) : UI7 (Mode Heat)

Volt [V]	500Ω [mA]	Heat Set Point (30 ~ 60) [°C]	Heat Set Point (86 ~ 140) [°F]	Etc
0.0	0.0	No Control (Disconnected)	No Control (Disconnected)	
0.2	0.4			
0.4	0.8			
0.6	1.2			
0.8	1.6			
1.0	2.0			
1.2	2.4			
1.4	2.8			
1.6	3.2			
1.8	3.6			
2.0	4.0	30	86	
2.2	4.4	31	87.8	
2.4	4.8	32	89.6	
2.6	5.2	33	91.4	
2.8	5.6	34	93.2	
3.0	6.0	35	95	
3.2	6.4	36	96.8	
3.4	6.8	37	98.6	
3.6	7.2	38	100.4	
3.8	7.6	39	102.2	
4.0	8.0	40	104	
4.2	8.4	41	105.8	
4.4	8.8	42	107.6	
4.6	9.2	43	109.4	
4.8	9.6	44	111.2	
5.0	10.0	45	113	
5.2	10.4	46	114.8	
5.4	10.8	47	116.6	
5.6	11.2	48	118.4	
5.8	11.6	49	120.2	
6.0	12.0	50	122	
6.2	12.4	51	123.8	
6.4	12.8	52	125.6	
6.6	13.2	53	127.4	
6.8	13.6	54	129.2	
7.0	14.0	55	131	
7.2	14.4	56	132.8	
7.4	14.8	57	134.6	
7.6	15.2	58	136.4	
7.8	15.6	59	138.2	
8	16	60	140	

3. Demand Limit (2 ~ 10 V, 4 ~ 20 mA) : UI8

Volt [V]	500Ω [mA]	Demand (50 ~ 100) [%]	Etc
0.0	0.0	No Control (Disconnected)	
0.5	1.0		
1.0	2.0		
1.5	3.0		
3.0	6.0	50%	
4.0	8.0	60%	
5.0	10.0	70%	
6.0	12.0	80%	
7.0	14.0	90%	
8.0	16.0	100%	

Check List

1 Project information

Content	Information
Project name	
Address	
Installed by	
Sold by	
Test run by	

2 Model information

Content	Information		
Product	Model name: Serial:	Model name: Serial:	Model name: Serial:
Compressor A	Model name: Serial:	Model name: Serial:	Model name: Serial:
Compressor B	Model name: Serial:	Model name: Serial:	Model name: Serial:

3 Preparation checklist

Content	Check	
Is there any damage?	Yes	No
Is the bolt/nut assembled properly?	Yes	No
Does the power specification match the product specification?	Yes	No
Is the wiring done accurately?	Yes	No
Is the product installed correctly?	Yes	No
Are the protective devices of the electric circuit installed correctly in accordance with the specification?	Yes	No
Are all the terminal blocks connected properly?	Yes	No
Are all plugs connected properly?	Yes	No

4 Check cold water system

Content	Check	
Are all valves connected to the chiller open?	Yes	No
Are all pipes connected accurately?	Yes	No
Is there any clog for drain pipe?	Yes	No
Is there any leakage?	Yes	No
Is the air within the system well discharged?	Yes	No
Is the cold water pump operating properly?	Yes	No
Is the cold water pump starter connected to the chiller properly?	Yes	No
Is the cold water flow switch operating?	Yes	No
Is the strainer installed on the pipe to the evaporator?	Yes	No



LG Electronics Inc. Single Point of Contact (Türkiye) :

Kaptanpasa Mah. Piyalepasa Bulvari
No:73 Ortadogu Plaza Kat:7 34384
Okmeydani, Sisli – Istanbul, Türkiye

Manufacturer :

LG Electronics Inc.
84, Wanam-ro, Seongsan-gu, Changwon-si, Gyeongsangnam-do, KOREA

Eco Design requirement

The information for Eco design is available on the following free access website.
<https://www.lg.com/global/support/cedoc/cedoc>