

A HEAT PUMP FOR A SUSTAINABLE FUTURE

# **THERMA V™ R290** Monobloc



[Browse now](#)

For more LG THERMA V information,  
please visit our website through QR code.



[www.lg.com](http://www.lg.com) <http://partner.lge.com>

Copyright © 2024 LG Electronics. All rights reserved.

THERMA V R290:  
HEATING THAT FEELS LIKE HOME

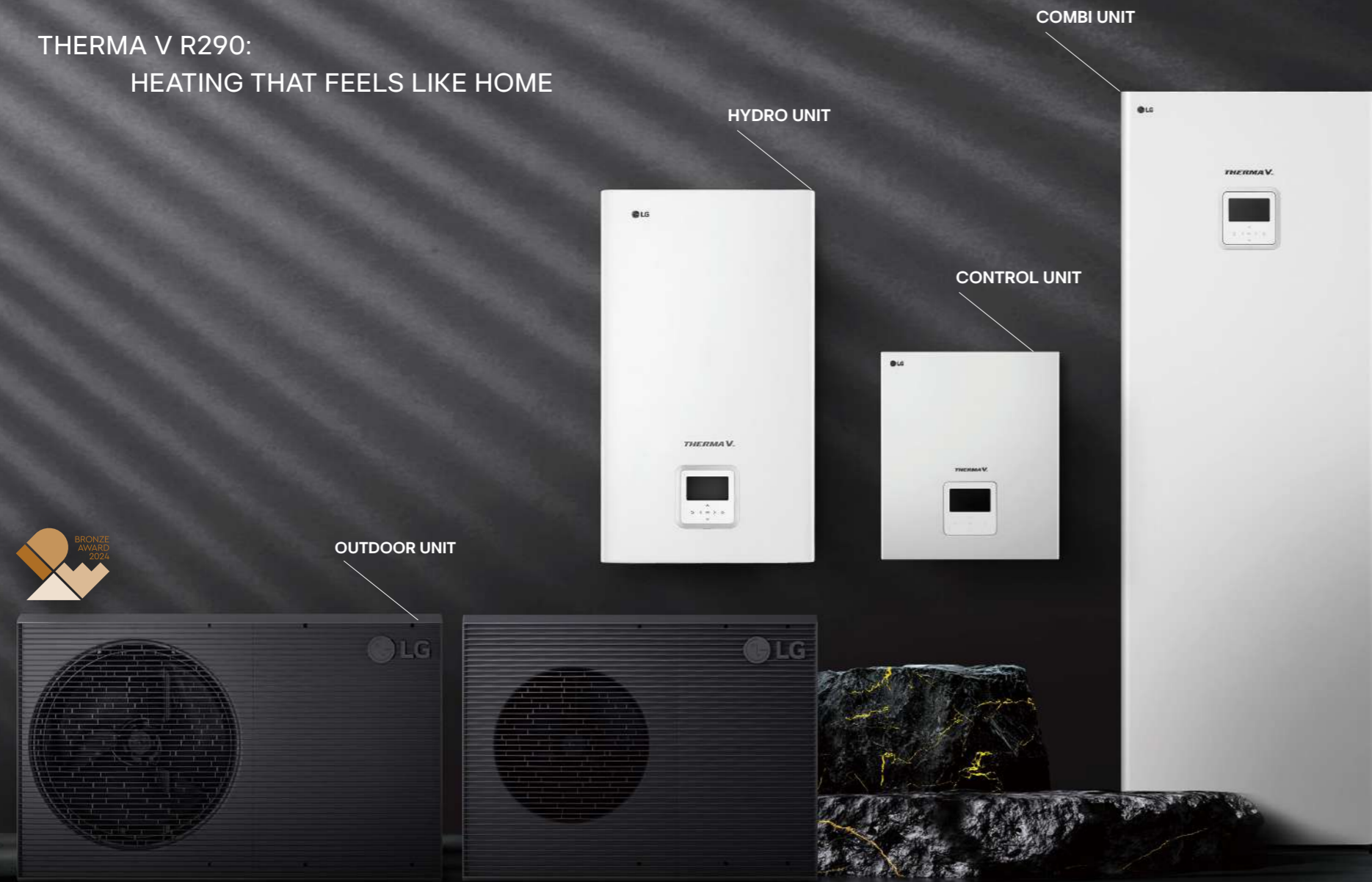

\* The product images above may differ from the actual products.

**Key Features**

- Capacity range with sizes from 7, 9, 12, 14, to 16 kW for renovation and large new builds
- Natural refrigerant R290 with low GWP (3)
- Refined gray design that adapts to various surroundings
- One of the quietest models on the market (49 dB(A) for 7 kW, 12 kW models)
- Maximum flow temperature up to 75°C
- Operation range down to -28°C
- Customized options through different three IDU combinations
- Provides 75°C leaving water even at -15°C outdoor temperatures (7/9 kW only)
- 2024 IDEA Design Awards Bronze Winner

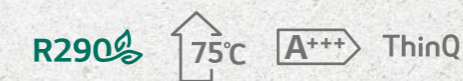

**Product Range**

Phase	Capacity (kW)	Indoor Unit			Outdoor Unit			
		Control Unit	Hydro Unit	Combi Unit				
1Ø	7	PHCSO	HN1616HC NK0	Available in 2Q, 2025	HM071HF UB40 HM091HF UB40			
	9			HN1616HY NK0	HM121HF UB60 HM141HF UB60 HM161HF UB60			
	12				HN1639HC NK0	Available in 2Q, 2025	HM123HF UB60 HM143HF UB60 HM163HF UB60	
	14							HN1639HY NK0
	16							
3Ø	7		HN1639HC NK0	HN1639HY NK0	Available in 2Q, 2025	HM073HF UB40 HM093HF UB40		
	9				HN1639HY NK0	HM123HF UB60 HM143HF UB60 HM163HF UB60		
	12						HN1639HY NK0	
	14							
	16							

**THERMAV™**

**T**op-notch reliability  
**H**igh energy efficiency  
**E**nvironmental stewardship  
**R**obust performance  
**M**odern design  
**A**dvanced smart technology  
**V**aluable experience



# Why choose **THERMA V™** R290 Monobloc

The new R290 Monobloc is a super-quiet, future-ready heat pump that uses R290 refrigerant, with a remarkably low Global Warming Potential (GWP) of just three. Its refined gray design ensures seamless integration with a wide variety of home and building exteriors. Thanks to its ultra-low noise levels, there's no need to worry about disturbing your neighbors when choosing an installation location. The LG THERMA V R290 Monobloc is available in three configurations—Control Unit, Hydro Unit, or Combi Unit—offering flexibility to meet every customer's unique needs.



## New Design European design



2024  
IDEA Design Awards  
Bronze Winner

## High reliability

Anti-icing and Deicing technologies for R290 Monobloc.



## Improved Operational Stability Freezing outside, but toasty inside

The R290 Monobloc can function in external temperatures as low as -28°C. Plus, customers can retain their existing radiators as the system can generate a water flow of up to 75°C, offering a cost-saving advantage. Even at -15°C, it is possible to provide an outlet water temperature of 75°C. (7 / 9 kW only)



## High Efficiency Operation Exceptional efficiency



## Achieving the highest ErP energy grade A+++ / A+++ for space heating

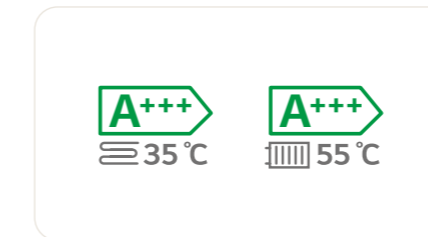

LG THERMA V R290 Monobloc  
(7 / 9 / 12 / 14 / 16 kW)

## Reduced annual energy costs

Estimated Average Annual Energy Costs\* in the EU (EU 27)  
As of April, 2024

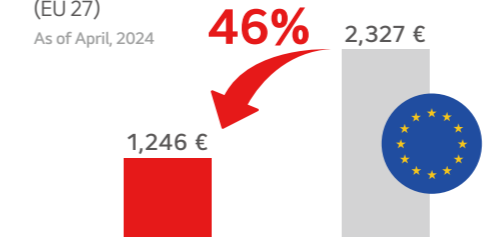

LG THERMA V R290 Monobloc 12 kW Gas Boiler

\* This is simulation result based on conditions under average climate & Medium temperature (55°C) and it may differ from actual value since there are many assumptions used.

## Convenience Easy installation

The two-way piping connection method not only grants greater installation flexibility but also offers distinct advantages when it comes to concealing underground piping for both aesthetic and frost protection purposes.

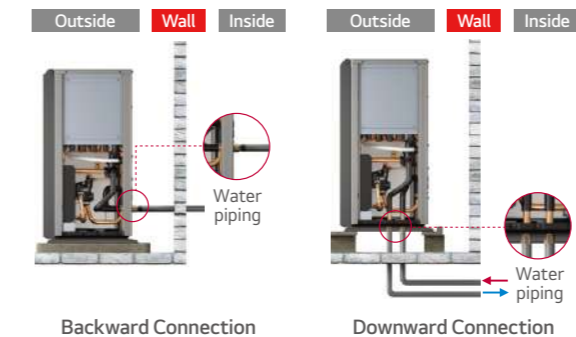

## Extremely Quiet Operation Heats home in hushed tones



R290 Monobloc	7 kW	9 kW	12 kW	14 kW	16 kW
Sound power level <sup>1)</sup> (heating / rated)	49	50	49	51	52
Sound power level <sup>1)</sup> (heating / low noise mode)	47	48	48	50	51

<sup>1)</sup> Sound power level is measured in accordance with EN 12102-1 and ISO 9614.

## Ensuring regulatory compliance across all EU markets

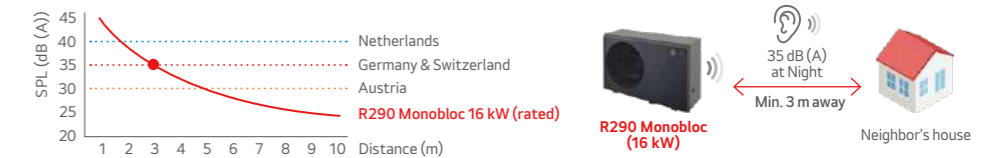

Customers can have peace of mind with no risk of complaints and no additional costs for acoustic enclosures.

## Freedom of Integration Customized combinations to meet diverse needs

Since THERMA V R290 Monobloc has hydro components integrated into the outdoor unit, it can be combined with various indoor units to implement applications tailored to customer needs.

Outdoor Unit	Indoor Unit Type	
<b>NEW</b> 		Control Unit • Stand-alone concept • Easy integration with 3 <sup>rd</sup> party equipment
		Hydro Unit • Back-up heater & expansion tank integrated inside
		Combi Unit <b>NEW</b> • DHW tank, back-up heater, expansion tank integrated inside • 200 l stainless steel tank • Except for 7 / 9 kW ODU

**THERMA V™**  
R290 Monobloc

# CONTROL UNIT

## Easy to Install, Minimal Space Required

Since the water pipe is not connected to the indoor unit and requires less installation space, it offers an easy installation process similar to the full Monobloc concept.

This setup is especially recommended for cases where the customer does not wish to install a backup heater, prefers to add it as a third-party accessory, or opts to install a larger expansion tank.



\* The product images above may differ from the actual products.

### What is Control Unit

- Stand-alone concept
- Light weight and compact size fits in small spaces
- Simple installation by minimizing piping and wiring work
- Easy integration with 3<sup>rd</sup> party equipment because of less cabling
- No pipe connections for the indoor unit allow for a neat installation

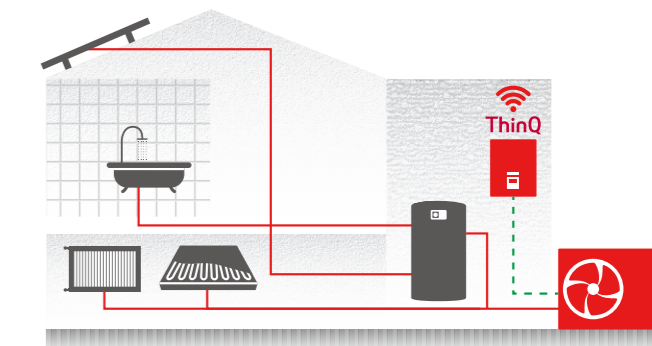

### Application



### Certifications



### Energy Label



1), 2) HM0\*\*HF models are in the certification process.

**THERMA V™**  
R290 Monobloc

# HYDRO UNIT

Optimized Solution,  
Time and Space  
Saving Design

The installation process is simplified as there is no need for refrigerant piping. An F-gas license is not required because the outdoor and indoor units are connected via water pipes.

Since the hydronic components are pre-packaged within the indoor units, the installation requires minimal space. Additionally, the refrigerant is hermetically sealed within the outdoor unit.



\* The product images above may differ from the actual products.

## What is Hydro Unit

- Integrated hydronic components - Backup heater, Expansion tank
- Space-saving solution with compact and light indoor unit
- Simple installation due to no refrigerant piping work

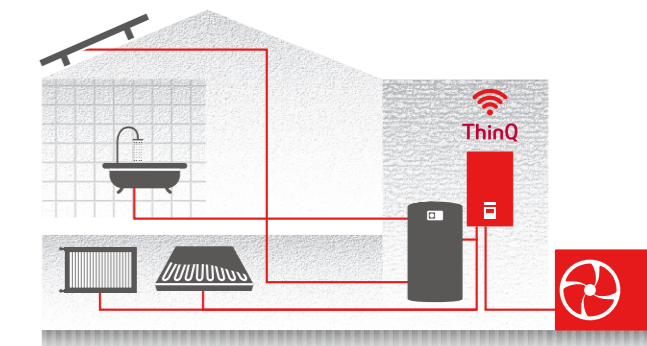

## Application



## Certifications



## Energy Label



1), 2) HMO\*\*HF models are in the certification process.

**THERMA V™**  
R290 Monobloc

# COMBI UNIT

## One-in-All All-in-One

Designed to streamline your home's heating, cooling, and hot water systems, this all-in-one solution provides seamless integration.

It efficiently saves space in your home.



\* The product images above may differ from the actual products.



### What is Combi Unit

- All-in-one Combi Unit with integrated hot water cylinder
- Saves space in the technical room with a small footprint
- Reduced installation time with pre-installed components
- Harmonized with other household appliances for a cohesive exterior

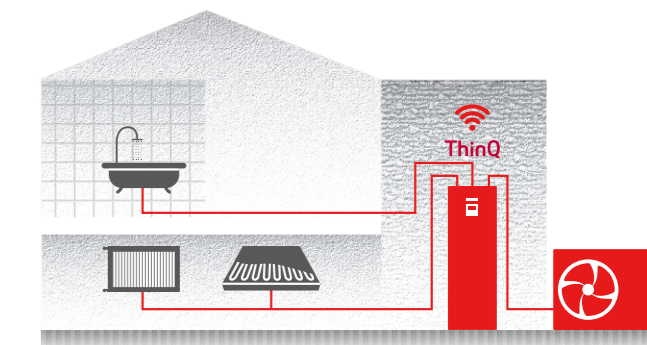

### Application



### Certifications



### Energy Label

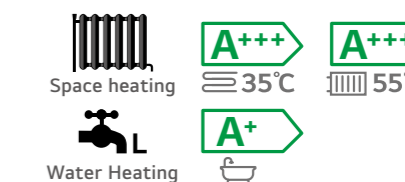

1), 2) HMO\*\*HF models are in the certification process.

## Control & Monitoring

Operate Your Heating System from Anywhere<sup>1)</sup>



Connect and control from anywhere, anytime



Simple control with voice assistant



Efficient energy monitoring



Download now



Download now

1) Mandatory accessory:  
 PWFMD200 (LG Wi-Fi Modem) / PWYREW000 (10 m extension connect cable in between THERMA V indoor and LG Wi-Fi Modem) could be required depending on installation conditions.  
 - Search "LG ThinQ" on Google Play or App Store, then download the app.  
 - Google assistant voice control may be restricted in use and language in some countries.  
 - Google and Google Home are trademarks of Google LLC.  
 - Voice-enabled smart speaker device is not included.

## Manage All Your LG Home Appliances in One App

The ThinQ platform allows you to control not only the THERMA V but also other LG products, all from one single app.



## Partner Program

Grow Together with LG All Stars



LG All Stars is our exciting new partner program that rewards engineers for doing what they do best. Within LG All Stars program, partners can enjoy access to exclusive benefits, trainings and a network of like-minded professionals. It is one-stop application and it is available for HVAC installers at all levels.

### How to Join the LG All Stars

#### Step 1

Scan the QR code below to register your information first for sign up.



[Link to sign up](#)

#### Step 2

Search and install for the LG All Stars application from the Google Play or Apple App Store on a smart phone.



[Download now](#)



[Download now](#)

※ The operation method and rewards of the LG All Stars program vary depending on the country.

## Accessories for R290 Monobloc

Item	Model Name
Outdoor air temp. sensor	PHATS0
Water tank sensor	PHRSTA0
Room temperature sensor	PQRSTA0
Thermistor for 2 <sup>nd</sup> circuit or e/heater	PRSTAT5K10
DHW tank kit	PHLTA
Drain pan	PHDPC
Cover plate	PDC-HK10
Wi-Fi modem	PWFMD200
Cloud gateway	PWFMD200

## Tools & Services

For all customers including designers, installers, and end users.

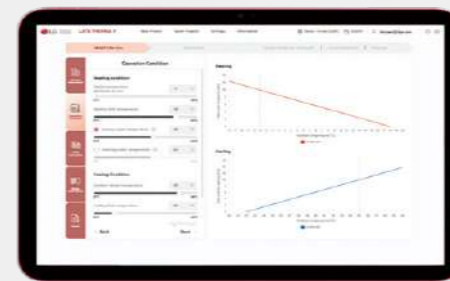

### LATS THERMA V

A web based selection and sizing tool that enables to choose optimized THERMA V model from various capacity range and simulates its energy cost comparing to other heating solutions. If you need to, you can download all the documents and reports related to your project.

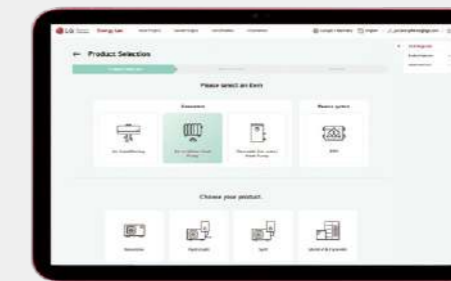

### LATS Energy Lab

LG Energy Lab online is a web version tool that can print energy labels. It is easy to use because it is composed of a user-friendly UI, and provides additional functions such as contact function and project management function.

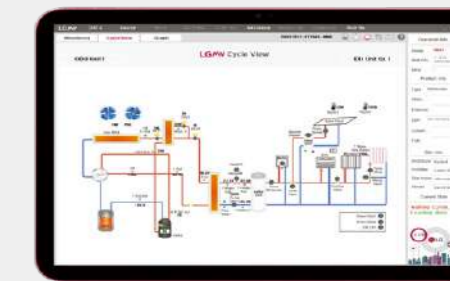

### LGMV

LGMV is a useful engineering tool that monitors THERMA V's real-time refrigerant and water cycle. It assists installers with effective and efficient start-up and commissioning after the THERMA V installation. LGMV enables service/field engineers to detect the errors and troubleshooting for fast and reliable problem solving.

\* LGMV is available on the LG partner portal.

## ThinQ and BECON cloud for Control, Maintenance, and Monitoring

With ThinQ, users can regulate the temperature and operation mode of the R290 Monobloc anytime, anywhere. Additionally, the BECON cloud enables installers or service partners to provide remote monitoring, servicing, and firmware upgrades as needed.

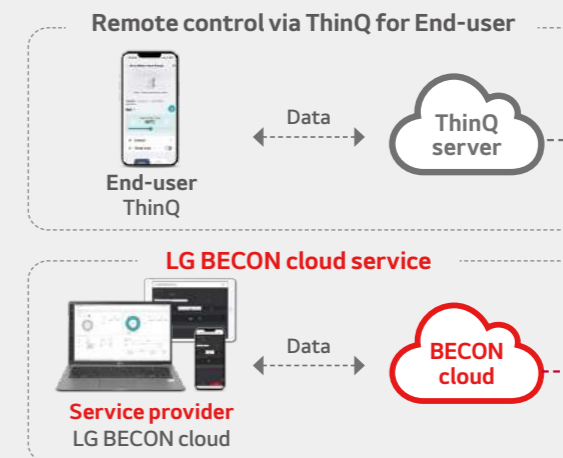

## Interior & Connections | Outdoor Unit

UB40 (7 / 9 kW)



UB60 (12 / 14 / 16 kW)



## Indoor Unit

Control Unit



Hydro Unit

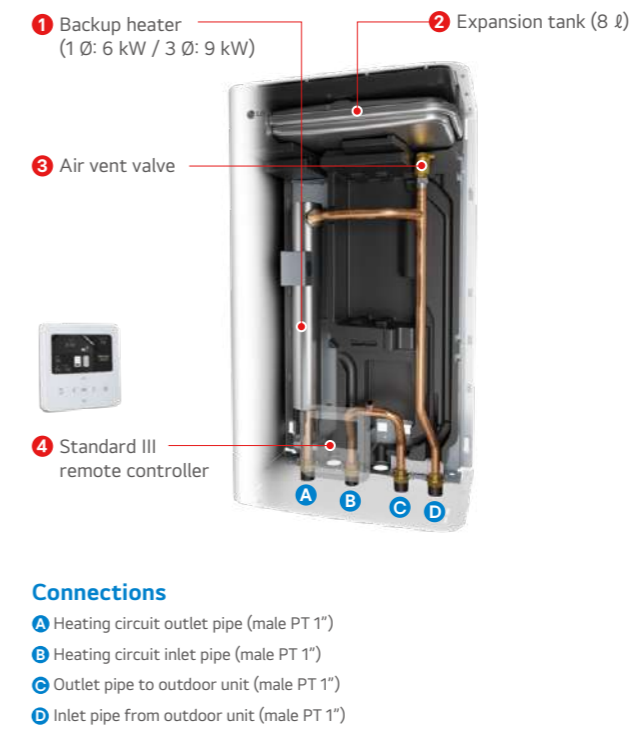

Combi Unit

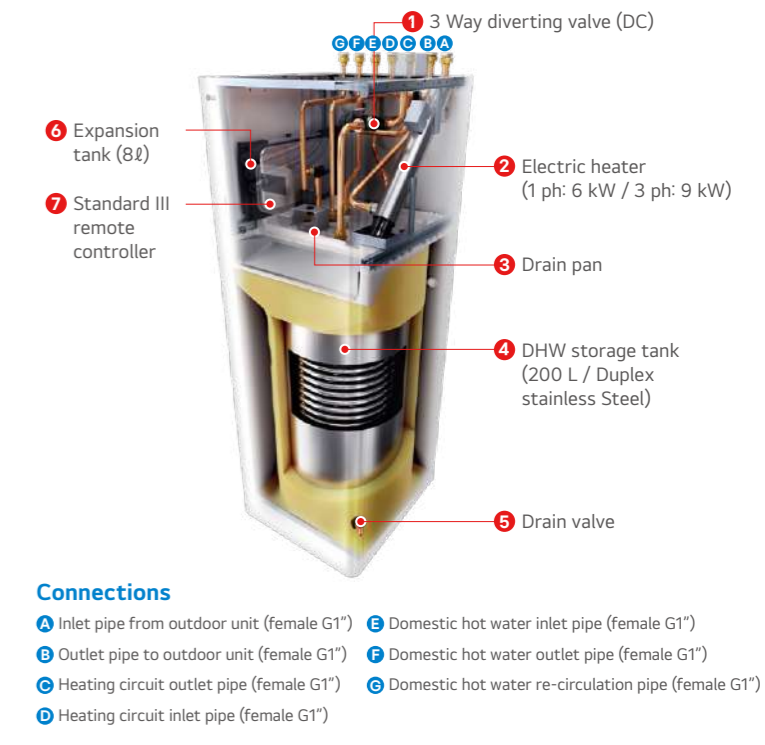

## Product Dimensions | Outdoor Unit

UB40 (7 / 9 kW)

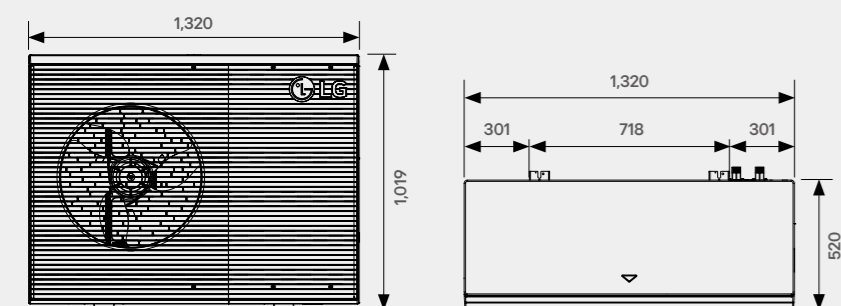

UB60 (12 / 14 / 16 kW)

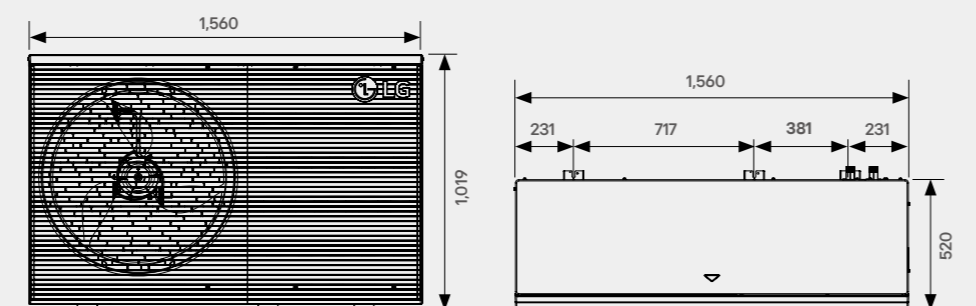

[unit: mm]

## Indoor Unit

Control Unit

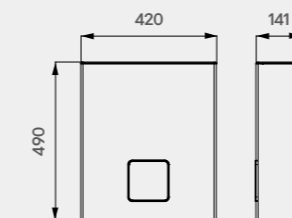

Hydro Unit

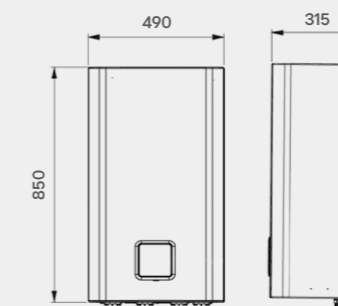

Combi Unit

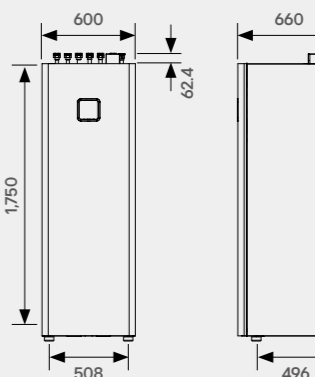

[unit: mm]

# Technical Data Table | R290 Monobloc

## Technical Specification (Outdoor Unit)

Efficiency Data		Unit	7 kW (1 Ø) / 7 kW (3 Ø)	9 kW (1 Ø) / 9 kW (3 Ø)	12 kW (1 Ø) / 12 kW (3 Ø)	14 kW (1 Ø) / 14 kW (3 Ø)	16 kW (1 Ø) / 16 kW (3 Ø)
Seasonal space heating eff. class (35°C / 55°C)		-	A+++ / A+++	A+++ / A+++	A+++ / A+++	A+++ / A+++	A+++ / A+++
Seasonal space heating efficiency (η <sub>s</sub> ) (35°C / 55°C)		%	207 / 151	205 / 151	215 / 156	212 / 155	201 / 154
SCOP (35°C / 55°C)		-	5.24 / 3.86	5.20 / 3.86	5.45 / 3.97	5.38 / 3.96	5.11 / 3.92
Water heating efficiency (profile L)		%	-	-	130	130	130
Nominal Capacity and COP / EER		Unit					
Air + 7°C / water + 35°C	Heating capacity / COP	kW / -	7.00 / 5.00	9.00 / 4.70	12.00 / 4.70	14.00 / 4.50	16.00 / 4.30
Air + 2°C / water + 35°C	Heating capacity / COP	kW / -	7.00 / 3.80	8.00 / 3.70	12.00 / 3.72	14.00 / 3.61	14.50 / 3.49
Air - 7°C / water + 35°C	Heating capacity / COP	kW / -	7.00 / 2.80	9.00 / 2.70	11.80 / 3.27	13.00 / 3.21	13.80 / 3.17
Air + 7°C / water + 55°C	Heating capacity / COP	kW / -	4.50 / 3.35	5.50 / 3.30	10.00 / 3.10	11.00 / 3.25	12.00 / 3.30
Air - 7°C / water + 55°C	Heating capacity / COP	kW / -	7.00 / 2.40	8.00 / 2.20	9.30 / 2.32	10.30 / 2.28	10.90 / 2.26
Air + 35°C / water + 18°C	Heating capacity / EER	kW / -	5.00 / 4.40	5.50 / 4.20	11.50 / 3.78	12.00 / 3.70	12.50 / 3.70
Air + 35°C / water + 7°C	Heating capacity / EER	kW / -	5.00 / 2.80	5.50 / 2.60	10.50 / 3.12	12.00 / 2.99	12.50 / 2.95
Outdoor Unit		Unit	HM071HF UB40 HM073HF UB40	HM091HF UB40 HM093HF UB40	HM121HF UB60 HM123HF UB60	HM141HF UB60 HM143HF UB60	HM161HF UB60 HM163HF UB60
Operation range (outdoor air temperature)	Heating & DHW (Min. ~ Max.)	°C	-28 ~ 35				
	Cooling (Min. ~ Max.)	°C	5 ~ 48				
Refrigerant	Type	-	R290				
	GWP	-	3				
	Precharged amount	g	900		1,200		
	t-CO <sub>2</sub> eq.	-	0.0027		0.0036		
Piping connections (water)	Inlet / outlet diameter	inch	Male PT 1" according to ISO 7-1 (tapered pipe threads)				
Dimension	W × H × D	mm	1,320 × 1,019 × 520		1,560 × 1,019 × 520		
Weight	Empty	kg	130.0		181.0		
Exterior	Color of chassis / RAL code	-	Dawn gray / RAL 7037				
	Color of front grille / RAL code	-	Dark dawn gray / RAL 7012				
Power supply	Voltage, phase, frequency	V, Ø, Hz	220 ~ 240, 1, 50 / 380 ~ 415, 3, 50				
	Recommended circuit breaker	A	1 Ø: 20 / 3 Ø: 16		1 Ø: 25 / 3 Ø: 16		
Sound power level	Rated / low noise mode	db(A)	49 / 48	50 / 48	49 / 48	51 / 50	52 / 51
Sound pressure level at 5 m <sup>1)</sup>	Rated / low noise mode	db(A)	27 / 26	28 / 26	27 / 26	29 / 28	30 / 29

1) Sound power level is measured in accordance with EN 12102-1 and ISO 9614. Sound pressure level is converted from sound power level based on a tonality penalty of 0 dB and installation in free-field. The directivity index (Q) is assumed as 2.

2) DHW 65 ~ 80°C operating is available only when the booster heater is operating.

3), 4) HM0\*\*HF models are in the certification process.



## Technical Specification (Indoor Unit)

Control Unit		Unit	PHCS0
Operation range (leaving water temperature)	Heating (Min. ~ Max.)	°C	15 ~ 75
	Cooling (Min. ~ Max.)	°C	5 ~ 27
	DHW (Min. ~ Max.)	°C	15 ~ 80 <sup>2)</sup>
Dimension	W × H × D	mm	420 × 490 × 141
Weight	Empty	kg	6.8
Exterior	Color / RAL code	-	Essence white / RAL 9003
Power supply	Voltage, phase, frequency	V, Ø, Hz	220 ~ 240, 1, 50
	Recommended circuit breaker	A	10
Hydro Unit		Unit	HN1616HC NK0 / HN1639HC NK0
Operation range (leaving water temperature)	Heating (Min. ~ Max.)	°C	15 ~ 75
	Cooling (Min. ~ Max.)	°C	5 ~ 27
	DHW (Min. ~ Max.)	°C	15 ~ 80 <sup>2)</sup>
Backup heater	Capacity combination	kW	3.0 + 3.0 / 3.0 + 3.0 + 3.0
	Power supply	V, Ø, Hz	220 ~ 240, 1, 50 / 380 ~ 415, 3, 50
	Rated running current	A	26 / 13
Piping connections (water)	Heating circuit outlet pipe	inch	Male PT 1" according to ISO 7-1 (tapered pipe threads)
	Heating circuit inlet pipe	inch	
	Outlet pipe to outdoor unit	inch	
	Inlet pipe to outdoor unit	inch	
Dimension	W × H × D	mm	490 × 850 × 315
Weight	Empty	kg	1 Ø: 30.0 / 3 Ø: 31.0
Exterior	Color / RAL code	-	Noble white / RAL 9016
Power supply	Voltage, phase, frequency	V, Ø, Hz	220 ~ 240, 1, 50
	Recommended circuit breaker	A	10
Sound power level	Rated	dB(A)	39
Sound pressure level at 1 m <sup>1)</sup>	Rated	dB(A)	31
Combi Unit		Unit	HN1616HY NK0 / HN1639HY NK0
Operation range (leaving water temperature)	Heating (Min. ~ Max.)	°C	15 ~ 75
	Cooling (Min. ~ Max.)	°C	5 ~ 27
	DHW (Min. ~ Max.)	°C	15 ~ 80 <sup>2)</sup>
Backup heater	Capacity combination	kW	3.0 + 3.0 / 3.0 + 3.0 + 3.0
	Power supply	V, Ø, Hz	220 ~ 240, 1, 50 / 380 ~ 415, 3, 50
	Rated running current	A	26 / 13
Piping connections (water)	Inlet / outlet diameter for ODU connection	inch	Female G1" according to ISO228-1 (parallel pipe threads)
	Inlet / outlet diameter for space heating	inch	
	Inlet / outlet diameter for DHW	inch	
	Recirculation	inch	
Dimension	W × H × D	mm	600 × 1,750 × 660
Weight	Empty	kg	1 Ø: 106.5 / 3 Ø: 107.0
Exterior	Color / RAL code	-	Noble white / RAL 9016
Power supply	Voltage, phase, frequency	V, Ø, Hz	220 ~ 240, 1, 50
	Recommended circuit breaker	A	10
Sound power level	Rated	dB(A)	39
Sound pressure level at 1 m <sup>1)</sup>	Rated	dB(A)	31