

LG

SINGLE

Free Combination

R32 Heat Pump (50Hz)

5CSL5-04B (Replaces: 5CSL5-04A)

TOTAL HVAC

SOLUTION

PROVIDER

ENGINEERING PRODUCT DATA BOOK

SINGLE

Outdoor Unit

General Information

Product Data

Installation of Outdoor Units

SINGLE



Outdoor Unit

General Information

- 1. Model Line Up**
- 2. Nomenclature**

1. Model Line Up

◆ 1 Phase Inverter

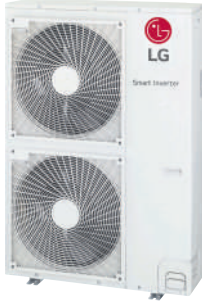
Model Names	ZUUW12GA1 [UUA1 UL0]	ZUUW24GA1 [UUB1 U20]	ZUUW30GA1 [UUC1 U40]	ZUUW48GA1 [UUD1 U30]
Power supply	1Ø, 220 - 240V, 50Hz			
External Appearance				

◆ 3 Phase Inverter

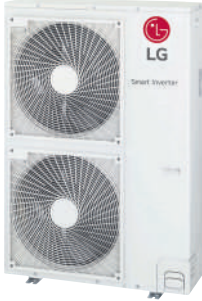
Model Names	ZUUW48LA1 [UUD3 U30]
Power supply	3Ø, 380 - 415V, 50Hz
External Appearance	

1. Model Line Up

■ Combination of Indoor and outdoor unit

◆ H-Inverter

Outdoor Unit		Indoor Unit						
Model Name	Capacity Index[kW (kBtu/h)]	Unit Type						
		Ceiling Cassette (4way)	Ceiling Cassette (Dual Vane 4way)	Ceiling Concealed Duct (Mid. Static Pressure)	Ceiling Concealed Duct (Low. Static Pressure)	Ceiling Suspended	Console	Wall Mounted
UUA1 UL0	2.5 (9)	UT09FH NQ0						
	3.4 (12)	UT12FH NQ0		UM12FH N10	UL12FH N50			
UUB1 U20	5.0 (18)		UT18FH NB0	UM18FH N10	UL18FH N30	UV18FH N10		
UUC1 U40	6.8 (24)		UT24FH NA0	UM24FH N20		UV24FH N20		
	8.0 (30)		UT30FH NA0	UM30FH N20		UV30FH N20		
UUD1 U30 UUD3 U30	9.5 (36)		UT36FH NA0	UM36FH N30		UV36FH N20		
	12.0 (42)		UT42FH NA0	UM42FH N30		UV42FH N20		
	13.4 (48)		UT48FH NA0	UM48FH N30				
	14.6 (60)		UT60FH NA0					

◆ Standard

Outdoor Unit		Indoor Unit							
Model Name	Capacity Index[kW (kBtu/h)]	Unit Type							
		Ceiling Cassette (4way)	Ceiling Cassette (Dual Vane 4way)	Ceiling Cassette (Round)	Ceiling Concealed Duct (Mid. Static Pressure)	Ceiling Concealed Duct (Low. Static Pressure)	Ceiling Suspended	Console	Wall Mounted
UUA1 UL0	2.5 (9)	CT09F NR0				CL09F N50		UQ09F NA0	MJ09PC NSJ
	3.4 (12)	CT12F NR0				CL12F N50		UQ12F NA0	MJ12PC NSJ
UUB1 U20	5.0 (18)	CT18F NQ0			CM18F N11 CM18F NA0	CL18F N60	UV18F N10	UQ18F NA0	MJ18PC NSK
UUC1 U40	6.8 (24)		CT24F NB0		CM24F N11 CM24F NA0	CL24F N30	UV24F N10		MJ24PC NSK
	8.0 (30)		UT30F NB0		UM30F N11 UM30F NA0		UV30F N10		US30F NR0
UUD1 U30 UUD3 U30	9.5 (36)		UT36F NA0	UT36F NY0	UM36F N21		UV36F N20		US36F NR0
	12.0 (42)		UT42F NA0		UM42F N21		UV42F N20		
	13.4 (48)		UT48F NA0	UT48F NY0	UM48F N31		UV48F N20		
	14.6 (60)		UT60F NA0		UM60F N31		UV60F N20		

◆ Compact

Outdoor Unit		Indoor Unit						
Model Name	Capacity Index[kW (kBtu/h)]	Unit Type						
		Ceiling Cassette (4way)	Ceiling Cassette (Dual Vane 4way)	Ceiling Concealed Duct (Mid. Static Pressure)	Ceiling Concealed Duct (Low. Static Pressure)	Ceiling Suspended	Console	Wall Mounted
UUA1 UL0	5.0 (18)	CT18F NQ0		CM18F N11 / CM18F NA0	CL18F N60	UV18F N10		
UUB1 U20	6.8 (24)		CT24F NB0	CM24F N11 / CM24F NA0	CL24F N30	UV24F N10		
	8.0 (30)		UT30F NB0	UM30F N11 / UM30F NA0		UV30F N10		US30F NR0
UUC1 U40	9.5 (36)		UT36F NA0	UM36F N21		UV36F N20		US36F NR0

2. Nomenclature

2.1 Outdoor units(Factory Model Name)

Model Name	ZUU	W	48	G	A	1
No.	1	2	3	4	5	6

No.	Signification
1	Indicates that this is a R32 SINGLE CAC Outdoor unit
2	Model type C : Cooling Only, H : Heat Pump, W: Inverter Heat Pump
3	Nominal capacity range based on 'kBtu/h' units 12 : 9~18 24 : 18~30 30 : 24~36 48 : 36~60
4	Electrical rating G: 1Ø, 220-240V, 50Hz L : 3Ø, 380-415V, 50Hz
5	Model Type A : H-Inverter / Standard / Compact
6	Serial No.

2.2 Outdoor units(Buyer Model Name)

Model Name	U	U	D	1	U3	0
No.	1	2	3	4	5	6

No.	Signification
1	Model type U : Universal model
2	Type U : Outdoor units
3	Nominal capacity range based on 'kBtu/h' units A : 9~18 B : 18~30 C : 24~36 D : 36~60
4	Electrical rating 1 : 1Ø, 220-240V, 50Hz 3 : 3Ø, 380-415V, 50Hz
5	Outdoor unit chassis name
6	Serial number

SINGLE

Outdoor Unit

Product Data

Outdoor Units

Outdoor Units - Synchro

SINGLE

Outdoor Unit

Outdoor Units

- 1. List of Functions**
- 2. Specifications**
- 3. Dimensions**
- 4. Piping Diagrams**
- 5. Wiring Diagrams**
- 6. Capacity Tables**
- 7. Capacity Correction Factor**
- 8. Operation Range**
- 9. Electric Characteristics**
- 10. Sound Levels**

1. List of Functions

■ 1 Phase Inverter

◆ List of function

Category	Functions	ZUUW12GA1 [UUA1 UL0]
Reliability	Defrost / Deicing	O
	High pressure switch	O
	Low pressure switch	X
	Phase protection	X
	Restart delay (3-minutes)	O
	Self diagnosis	O
	Soft start	O
Convenience	Test function	O
	Night Low Noise Operation	X
	Wiring Error Check	X
	Peak Control	X
	Mode Lock	X
	Forced Cooling Operation (Outdoor Unit)	X
Network function	Network solution(LGAP)	O
ODU Dry Contact		X

Note

1. O : Applied, X : Not applied

Accessory : Ordered and purchased separately the accessory package referring to the model name provided and install at field.
Accessory line-ups varies by region, so check your local catalogue or local sales material.

◆ Accessory Compatibility List

Category	Product	Etc	ZUUW12GA1 [UUA1 UL0]	
Central Controller	Simple	PQCSZ250S0	AC EZ	O
	AC Ez Touch	PACEZA000	AC Ez Touch	O
	AC Smart	PACS5A000	AC Smart 5	O
	ACP	PACP5A000	ACP 5	O
	AC Manager ¹⁾	PACM5A000	AC Manager 5	O
Gateway	ODU PI485	PMNFP14A1	PI 485 Gateway	O
	Low Ambient Kit	PRVC2	From MULTI V IV series	-
	AHU Comm. Kit	PAHCMR000	Return Air Temperature Control	X
		PAHCMS000	Discharge Air Temperature Control	X
	BACnet	PQNFB17C0	ACP BACnet	O
	Lonworks	PLNWKB000	ACP Lonworks	O
ETC	PDI	PPWRDB000	PDI Standard	O
		PQNUD1S40	PDI Premium	O
	ACS IO Module	PEXPMB000	-	X

Note

1. O: Possible, X: Impossible, -: Not applicable

2. *: Some advanced functions controlled by individual controller cannot be operated.

3. ¹⁾: ACP or AC Smart is needed.

4. Compatibility of individual controller(wireless/wired remote controller) could be found with function list on Indoor Unit's PDB.

5. If you need more detail, please refer to the **BECON** PDB or the manual of product.

(<http://partner.lge.com/global> : Home> Doc.Library> Product > Control(BECON))

1. List of Functions

◆ List of function

Category	Functions	ZUUW24GA1 [UUB1 U20] ZUUW30GA1 [UUC1 U40] ZUUW48GA1 [UUD1 U30]
Reliability	Defrost / Deicing	O
	High pressure switch	O
	Low pressure switch	X
	Phase protection	X
	Restart delay (3-minutes)	O
	Self diagnosis	O
	Soft start	O
Convenience	Test function	O
	Night Low Noise Operation	O
	Wiring Error Check	X
	Peak Control	O
	Mode Lock	O
	Forced Cooling Operation (Outdoor Unit)	O
Network function	Network solution(LGAP)	O
ODU Dry Contact		X

Note

1. O : Applied, X : Not applied

Accessory : Ordered and purchased separately the accessory package referring to the model name provided and install at field.

Accessory line-ups varies by region, so check your local catalogue or local sales material.

◆ Accessory Compatibility List

Category	Product	Etc	ZUUW24GA1 [UUB1 U20] ZUUW30GA1 [UUC1 U40] ZUUW48GA1 [UUD1 U30]	
Central Controller	Simple	PQCSZ250S0	AC EZ	O
	AC Ez Touch	PACEZA000	AC Ez Touch	O
	AC Smart	PACS5A000	AC Smart 5	O
	ACP	PACP5A000	ACP 5	O
	AC Manager ¹⁾	PACM5A000	AC Manager 5	O
Gateway	ODU PI485	PMNFP14A1	PI 485 Gateway	O
	Low Ambient Kit	PRVC2	From MULTI V IV series	-
	AHU Comm. Kit	PAHCMR000	Return Air Temperature Control	O
		PAHCMS000	Discharge Air Temperature Control	O
	BACnet	PQNFB17C0	ACP BACnet	O
	Lonworks	PLNWKB000	ACP Lonworks	O
ETC	PDI	PPWRDB000	PDI Standard	O
		PQNUD1S40	PDI Premium	O
	ACS IO Module	PEXPMB000	-	X

Note

1. O: Possible, X: Impossible, -: Not applicable

2. *: Some advanced functions controlled by individual controller cannot be operated.

3. ¹⁾: ACP or AC Smart is needed.

4. Compatibility of individual controller(wireless/wired remote controller) could be found with function list on Indoor Unit's PDB.

5. If you need more detail, please refer to the **BECON** PDB or the manual of product.

(<http://partner.lge.com/global> : Home> Doc.Library> Product > Control(BECON))

1. List of Functions

■ 3 Phase Inverter

◆ List of function

Category	Functions	ZUUW48LA1 [UUD3 U30]
Reliability	Defrost / Deicing	O
	High pressure switch	O
	Low pressure switch	X
	Phase protection	O
	Restart delay (3-minutes)	O
	Self diagnosis	O
	Soft start	O
Convenience	Test function	O
	Night Low Noise Operation	O
	Wiring Error Check	X
	Peak Control	O
	Mode Lock	O
	Forced Cooling Operation (Outdoor Unit)	O
Network function	Network solution(LGAP)	O
ODU Dry Contact		X

Note

1. O : Applied, X : Not applied

Accessory : Ordered and purchased separately the accessory package referring to the model name provided and install at field.

Accessory line-ups varies by region, so check your local catalogue or local sales material.

◆ Accessory Compatibility List

Category	Product	Etc	ZUUW48LA1 [UUD3 U30]	
Central Controller	Simple	PQCSZ250S0	AC EZ	O
	AC Ez Touch	PACEZA000	AC Ez Touch	O
	AC Smart	PACS5A000	AC Smart 5	O
	ACP	PACP5A000	ACP 5	O
	AC Manager ¹⁾	PACM5A000	AC Manager 5	O
Gateway	ODU PI485	PMNFP14A1	PI 485 Gateway	O
	Low Ambient Kit	PRVC2	From MULTI V IV series	-
	AHU Comm. Kit	PAHCMR000	Return Air Temperature Control	O
		PAHCMS000	Discharge Air Temperature Control	O
	BACnet	PQNFB17C0	ACP BACnet	O
	Lonworks	PLNWKB000	ACP Lonworks	O
ETC	PDI	PPWRDB000	PDI Standard	O
		PQNUD1S40	PDI Premium	O
	ACS IO Module	PEXPMB000	-	X

Note

1. O: Possible, X: Impossible, -: Not applicable

2. *: Some advanced functions controlled by individual controller cannot be operated.

3. ¹⁾: ACP or AC Smart is needed.

4. Compatibility of individual controller(wireless/wired remote controller) could be found with function list on Indoor Unit's PDB.

5. If you need more detail, please refer to the **BECON** PDB or the manual of product.

(<http://partner.lge.com/global> : Home> Doc.Library> Product > Control(BECON))

2. Specifications

2.1 Combinational Specifications

■ H-Inverter(1 Phase Inverter)

Combination	Outdoor unit			ZUUW12GA1 [UUA1 UL0]
	Indoor unit			ZTNW09QLH1 [UT09FH NQ0]
Capacity	Cooling	Min.~Rated~Max.	kW	1.60 ~ 2.50 ~ 4.00
	Heating	Min.~Rated~Max.	kW	1.70 ~ 3.20 ~ 4.50
Power Input	Cooling	Min.~Rated~Max.	kW	0.32 ~ 0.61 ~ 0.98
	Heating	Min.~Rated~Max.	kW	0.32 ~ 0.75 ~ 1.06
Running Current	Cooling	Rated	A	2.70
	Heating	Rated	A	3.30
EER / COP			W / W	4.10 / 4.30
SEER / SCOP			Wh / Wh	7.00 / 4.00
Seasonal Energy Label		Cooling / Heating	-	A++ / A+
Annual Energy Consumption		Cooling / Heating	kWh	125 / 980
Dehumidification Rate			ℓ/h	0.11
ODU Sound Pressure Level	Cooling	Rated	dB(A)	49
	Heating	Rated	dB(A)	52
ODU Sound Power Level	Cooling	Rated	dB(A)	65
	Heating	Rated	dB(A)	-
Piping Connections	Liquid	Outer Dia.	mm (inch)	∅ 6.35 (1/4)
	Gas	Outer Dia.	mm (inch)	∅ 9.52 (3/8)
Piping Length		Rated	m	7.5
		Min. / Max.	m	5.0 / 30.0
Refrigerant	Type		-	R32
	GWP (Global Warming Potential)		-	675
	Precharged Amount		g	1,000
	t-CO ₂ eq.		-	0.675
	Control		-	EEV
	Chargeless-Pipe Length		m	10
	Additional Charging Volume		g/m	20

Note

1. Due to our policy of innovation some specifications may be changed without notification.
2. Wiring cable size must comply with the applicable local and national codes. And "Electric characteristics" chapter should be considered for electrical work and design. Especially the power cable and circuit breaker should be selected in accordance with that.
3. Power factor could vary less than ±1% according to the operating conditions.
4. Sound pressure level is measured on the rated condition in the anechoic rooms by ISO 3745 standard.
Sound power level is measured on the rated condition in the reverberation rooms by ISO 3741 standard.
Therefore, these values can be increased owing to ambient conditions during operation.
5. Performances are based on the following conditions (It is accordance with EN14511) :
 - *Cooling : Indoor Ambient Temp. 27°CDB / 19°CWB, Outdoor Ambient Temp. 35°CDB / 24°CWB
 - *Heating : Indoor Ambient Temp. 20°CDB / 15°CWB, Outdoor Ambient Temp. 7°CDB / 6°CWB
 - Interconnected Pipe is standard length and difference of Elevation (Outdoor ~ Indoor Unit) is 0m.
6. This product contains Fluorinated greenhouse gases.

2. Specifications

Combination	Outdoor unit			ZUUW12GA1 [UUA1 UL0]	
	Indoor unit			ZTNW12GQLH1 [UT12FH NQ0]	ZBNW12GM1H1 [UM12FH N10]
Capacity	Cooling	Min.~Rated~Max.	kW	1.60 ~ 3.40 ~ 4.80	1.60 ~ 3.50 ~ 5.10
	Heating	Min.~Rated~Max.	kW	1.70 ~ 4.10 ~ 5.80	1.60 ~ 4.00 ~ 5.80
Power Input	Cooling	Min.~Rated~Max.	kW	0.32 ~ 0.97 ~ 1.78	0.32 ~ 1.03 ~ 1.93
	Heating	Min.~Rated~Max.	kW	0.32 ~ 1.03 ~ 1.87	0.32 ~ 0.98 ~ 1.85
Running Current	Cooling	Rated	A	4.30	4.60
	Heating	Rated	A	4.60	4.30
EER / COP			W / W	3.50 / 4.00	3.40 / 4.10
SEER / SCOP			Wh / Wh	6.80 / 4.00	6.10 / 3.90
Seasonal Energy Label		Cooling / Heating	-	A++ / A+	A++ / A
Annual Energy Consumption		Cooling / Heating	kWh	175 / 980	201 / 1,005
Dehumidification Rate			ℓ/h	0.8	0.39
ODU Sound Pressure Level	Cooling	Rated	dB(A)	49	49
	Heating	Rated	dB(A)	52	52
ODU Sound Power Level	Cooling	Rated	dB(A)	65	65
	Heating	Rated	dB(A)	-	-
Piping Connections	Liquid	Outer Dia.	mm (inch)	Ø 6.35 (1/4)	Ø 6.35 (1/4)
	Gas	Outer Dia.	mm (inch)	Ø 9.52 (3/8)	Ø 9.52 (3/8)
Piping Length	Rated		m	7.5	7.5
	Min. / Max.		m	5.0 / 30.0	5.0 / 30.0
Refrigerant	Type		-	R32	R32
	GWP (Global Warming Potential)		-	675	675
	Precharged Amount		g	1,000	1,000
	t-CO ₂ eq.		-	0.675	0.675
	Control		-	EEV	EEV
	Chargeless-Pipe Length		m	10	10
	Additional Charging Volume		g/m	20	20

Note

- Due to our policy of innovation some specifications may be changed without notification.
- Wiring cable size must comply with the applicable local and national codes. And "Electric characteristics" chapter should be considered for electrical work and design. Especially the power cable and circuit breaker should be selected in accordance with that.
- Power factor could vary less than ±1% according to the operating conditions.
- Sound pressure level is measured on the rated condition in the anechoic rooms by ISO 3745 standard.
Sound power level is measured on the rated condition in the reverberation rooms by ISO 3741 standard.
Therefore, these values can be increased owing to ambient conditions during operation.
- Performances are based on the following conditions (It is accordance with EN14511) :
 - *Cooling : Indoor Ambient Temp. 27°CDB / 19°CWB, Outdoor Ambient Temp. 35°CDB / 24°CWB
 - *Heating : Indoor Ambient Temp. 20°CDB / 15°CWB, Outdoor Ambient Temp. 7°CDB / 6°CWB
 - Interconnected Pipe is standard length and difference of Elevation (Outdoor ~ Indoor Unit) is 0m.
- This product contains Fluorinated greenhouse gases.

2. Specifications

Combination	Outdoor unit			ZUUW12GA1 [UUA1 UL0]
	Indoor unit			ZBNW12GL5H1 [UL12FH N50]
Capacity	Cooling	Min.~Rated~Max.	kW	1.50 ~ 3.40 ~ 4.70
	Heating	Min.~Rated~Max.	kW	1.80 ~ 4.00 ~ 4.90
Power Input	Cooling	Min.~Rated~Max.	kW	0.33 ~ 1.05 ~ 1.84
	Heating	Min.~Rated~Max.	kW	0.33 ~ 1.08 ~ 1.63
Running Current	Cooling	Rated	A	4.70
	Heating	Rated	A	4.80
EER / COP			W / W	3.23 / 3.71
SEER / SCOP			Wh / Wh	6.10 / 4.00
Seasonal Energy Label		Cooling / Heating	-	A++ / A+
Annual Energy Consumption		Cooling / Heating	kWh	195 / 1,015
Dehumidification Rate			ℓ/h	0.78
ODU Sound Pressure Level	Cooling	Rated	dB(A)	49
	Heating	Rated	dB(A)	52
ODU Sound Power Level	Cooling	Rated	dB(A)	65
	Heating	Rated	dB(A)	-
Piping Connections	Liquid	Outer Dia.	mm (inch)	Ø 6.35 (1/4)
	Gas	Outer Dia.	mm (inch)	Ø 9.52 (3/8)
Piping Length	Rated		m	7.5
	Min. / Max.		m	5.0 / 30.0
Refrigerant	Type		-	R32
	GWP (Global Warming Potential)		-	675
	Precharged Amount		g	1,000
	t-CO ₂ eq.		-	0.675
	Control		-	EEV
	Chargeless-Pipe Length		m	10
	Additional Charging Volume		g/m	20

Note

- Due to our policy of innovation some specifications may be changed without notification.
- Wiring cable size must comply with the applicable local and national codes. And "Electric characteristics" chapter should be considered for electrical work and design. Especially the power cable and circuit breaker should be selected in accordance with that.
- Power factor could vary less than ±1% according to the operating conditions.
- Sound pressure level is measured on the rated condition in the anechoic rooms by ISO 3745 standard.
Sound power level is measured on the rated condition in the reverberation rooms by ISO 3741 standard.
Therefore, these values can be increased owing to ambient conditions during operation.
- Performances are based on the following conditions (It is accordance with EN14511) :
 - *Cooling : Indoor Ambient Temp. 27°CDB / 19°CWB, Outdoor Ambient Temp. 35°CDB / 24°CWB
 - *Heating : Indoor Ambient Temp. 20°CDB / 15°CWB, Outdoor Ambient Temp. 7°CDB / 6°CWB
 - Interconnected Pipe is standard length and difference of Elevation (Outdoor ~ Indoor Unit) is 0m.
- This product contains Fluorinated greenhouse gases.

2. Specifications

Combination	Outdoor unit			ZUUW24GA1 [UUB1 U20]	
	Indoor unit			ZTNW18GBLH1 [UT18FH NB0]	ZBNW18GM1H1 [UM18FH N10]
Capacity	Cooling	Min.~Rated~Max.	kW	2.00 ~ 5.00 ~ 6.00	2.00 ~ 5.00 ~ 6.00
	Heating	Min.~Rated~Max.	kW	2.30 ~ 5.80 ~ 7.00	2.30 ~ 5.80 ~ 7.00
Power Input	Cooling	Min.~Rated~Max.	kW	0.30 ~ 1.25 ~ 1.69	0.30 ~ 1.26 ~ 1.70
	Heating	Min.~Rated~Max.	kW	0.30 ~ 1.47 ~ 1.98	0.30 ~ 1.49 ~ 2.01
Running Current	Cooling	Rated	A	7.20	7.30
	Heating	Rated	A	7.70	7.80
EER / COP			W / W	4.00 / 3.95	3.96 / 3.89
SEER / SCOP			Wh / Wh	7.60 / 4.40	6.60 / 4.20
Seasonal Energy Label		Cooling / Heating	-	A++ / A+	A++ / A+
Annual Energy Consumption		Cooling / Heating	kWh	230 / 1,305	265 / 1,467
Dehumidification Rate			ℓ/h	1.91	1.26
ODU Sound Pressure Level	Cooling	Rated	dB(A)	47	47
	Heating	Rated	dB(A)	52	52
ODU Sound Power Level	Cooling	Rated	dB(A)	63	63
	Heating	Rated	dB(A)	-	-
Piping Connections	Liquid	Outer Dia.	mm (inch)	Ø 6.35 (1/4)	Ø 6.35 (1/4)
	Gas	Outer Dia.	mm (inch)	Ø 12.7 (1/2)	Ø 12.7 (1/2)
Piping Length	Rated		m	7.5	7.5
	Min. / Max.		m	5.0 / 30.0	5.0 / 30.0
Refrigerant	Type		-	R32	R32
	GWP (Global Warming Potential)		-	675	675
	Precharged Amount		g	1,200	1,200
	t-CO ₂ eq.		-	0.810	0.810
	Control		-	EEV	EEV
	Chargeless-Pipe Length		m	10	10
	Additional Charging Volume		g/m	20	20

Note

- Due to our policy of innovation some specifications may be changed without notification.
- Wiring cable size must comply with the applicable local and national codes. And "Electric characteristics" chapter should be considered for electrical work and design. Especially the power cable and circuit breaker should be selected in accordance with that.
- Power factor could vary less than ±1% according to the operating conditions.
- Sound pressure level is measured on the rated condition in the anechoic rooms by ISO 3745 standard.
Sound power level is measured on the rated condition in the reverberation rooms by ISO 3741 standard.
Therefore, these values can be increased owing to ambient conditions during operation.
- Performances are based on the following conditions (It is accordance with EN14511) :
 - *Cooling : Indoor Ambient Temp. 27°CDB / 19°CWB, Outdoor Ambient Temp. 35°CDB / 24°CWB
 - *Heating : Indoor Ambient Temp. 20°CDB / 15°CWB, Outdoor Ambient Temp. 7°CDB / 6°CWB
 - Interconnected Pipe is standard length and difference of Elevation (Outdoor ~ Indoor Unit) is 0m.
- This product contains Fluorinated greenhouse gases.

2. Specifications

Combination	Outdoor unit			ZUUW24GA1 [UUB1 U20]	
	Indoor unit			ZBNW18GL3H1 [UL18FH N30]	ZVNW18GM1H1 [UV18FH N10]
Capacity	Cooling	Min.~Rated~Max.	kW	2.00 ~ 5.00 ~ 6.00	2.00 ~ 5.00 ~ 6.00
	Heating	Min.~Rated~Max.	kW	2.30 ~ 5.80 ~ 7.00	2.30 ~ 5.80 ~ 7.00
Power Input	Cooling	Min.~Rated~Max.	kW	0.30 ~ 1.39 ~ 1.88	0.30 ~ 1.28 ~ 1.73
	Heating	Min.~Rated~Max.	kW	0.30 ~ 1.56 ~ 2.12	0.30 ~ 1.56 ~ 2.13
Running Current	Cooling	Rated	A	7.60	7.30
	Heating	Rated	A	8.10	8.00
EER / COP			W / W	3.60 / 3.71	3.90 / 3.71
SEER / SCOP			Wh / Wh	6.50 / 4.10	7.60 / 4.40
Seasonal Energy Label		Cooling / Heating	-	A++ / A+	A++ / A+
Annual Energy Consumption		Cooling / Heating	kWh	269 / 1,400	230 / 1,368
Dehumidification Rate			ℓ/h	2.57	1.85
ODU Sound Pressure Level	Cooling	Rated	dB(A)	47	47
	Heating	Rated	dB(A)	52	52
ODU Sound Power Level	Cooling	Rated	dB(A)	63	63
	Heating	Rated	dB(A)	-	-
Piping Connections	Liquid	Outer Dia.	mm (inch)	Ø 6.35 (1/4)	Ø 6.35 (1/4)
	Gas	Outer Dia.	mm (inch)	Ø 12.7 (1/2)	Ø 12.7 (1/2)
Piping Length	Rated		m	7.5	7.5
	Min. / Max.		m	5.0 / 30.0	5.0 / 30.0
Refrigerant	Type		-	R32	R32
	GWP (Global Warming Potential)		-	675	675
	Precharged Amount		g	1,200	1,200
	t-CO ₂ eq.		-	0.810	0.810
	Control		-	EEV	EEV
	Chargeless-Pipe Length		m	10	10
	Additional Charging Volume		g/m	20	20

Note

- Due to our policy of innovation some specifications may be changed without notification.
- Wiring cable size must comply with the applicable local and national codes. And "Electric characteristics" chapter should be considered for electrical work and design. Especially the power cable and circuit breaker should be selected in accordance with that.
- Power factor could vary less than ±1% according to the operating conditions.
- Sound pressure level is measured on the rated condition in the anechoic rooms by ISO 3745 standard.
Sound power level is measured on the rated condition in the reverberation rooms by ISO 3741 standard.
Therefore, these values can be increased owing to ambient conditions during operation.
- Performances are based on the following conditions (It is accordance with EN14511) :
 - *Cooling : Indoor Ambient Temp. 27°CDB / 19°CWB, Outdoor Ambient Temp. 35°CDB / 24°CWB
 - *Heating : Indoor Ambient Temp. 20°CDB / 15°CWB, Outdoor Ambient Temp. 7°CDB / 6°CWB
 - Interconnected Pipe is standard length and difference of Elevation (Outdoor ~ Indoor Unit) is 0m.
- This product contains Fluorinated greenhouse gases.

2. Specifications

Combination	Outdoor unit			ZUUW30GA1 [UUC1 U40]	
	Indoor unit			ZTNW24GALH1 [UT24FH NA0]	ZBNW24GM2H1 [UM24FH N20]
Capacity	Cooling	Min.~Rated~Max.	kW	2.70 ~ 6.80 ~ 8.30	2.70 ~ 6.80 ~ 8.30
	Heating	Min.~Rated~Max.	kW	3.20 ~ 7.90 ~ 9.90	3.00 ~ 7.50 ~ 9.40
Power Input	Cooling	Min.~Rated~Max.	kW	0.30 ~ 1.66 ~ 2.31	0.40 ~ 1.84 ~ 2.56
	Heating	Min.~Rated~Max.	kW	0.40 ~ 1.76 ~ 2.53	0.40 ~ 1.75 ~ 2.52
Running Current	Cooling	Rated	A	7.40	8.20
	Heating	Rated	A	7.80	7.80
EER / COP			W / W	4.10 / 4.48	3.70 / 4.28
SEER / SCOP			Wh / Wh	8.50 / 4.80	6.80 / 4.30
Seasonal Energy Label		Cooling / Heating	-	A+++ / A++	A++ / A+
Annual Energy Consumption		Cooling / Heating	kWh	280 / 1,604	350 / 1,758
Dehumidification Rate			ℓ/h	1.70	1.20
ODU Sound Pressure Level	Cooling	Rated	dB(A)	48	48
	Heating	Rated	dB(A)	52	52
ODU Sound Power Level	Cooling	Rated	dB(A)	65	65
	Heating	Rated	dB(A)	-	-
Piping Connections	Liquid	Outer Dia.	mm (inch)	Ø 9.52 (3/8)	Ø 9.52 (3/8)
	Gas	Outer Dia.	mm (inch)	Ø 15.88 (5/8)	Ø 15.88 (5/8)
Piping Length	Rated		m	7.5	7.5
	Min. / Max.		m	5.0 / 50.0	5.0 / 50.0
Refrigerant	Type		-	R32	R32
	GWP (Global Warming Potential)		-	675	675
	Precharged Amount		g	1,900	1,900
	t-CO ₂ eq.		-	1.283	1.283
	Control		-	EEV	EEV
	Chargeless-Pipe Length		m	20	20
	Additional Charging Volume		g/m	55	55

Note

- Due to our policy of innovation some specifications may be changed without notification.
- Wiring cable size must comply with the applicable local and national codes. And "Electric characteristics" chapter should be considered for electrical work and design. Especially the power cable and circuit breaker should be selected in accordance with that.
- Power factor could vary less than ±1% according to the operating conditions.
- Sound pressure level is measured on the rated condition in the anechoic rooms by ISO 3745 standard.
Sound power level is measured on the rated condition in the reverberation rooms by ISO 3741 standard.
Therefore, these values can be increased owing to ambient conditions during operation.
- Performances are based on the following conditions (It is accordance with EN14511) :
 - *Cooling : Indoor Ambient Temp. 27°CDB / 19°CWB, Outdoor Ambient Temp. 35°CDB / 24°CWB
 - *Heating : Indoor Ambient Temp. 20°CDB / 15°CWB, Outdoor Ambient Temp. 7°CDB / 6°CWB
 - Interconnected Pipe is standard length and difference of Elevation (Outdoor ~ Indoor Unit) is 0m.
- This product contains Fluorinated greenhouse gases.

2. Specifications

Combination	Outdoor unit			ZUUW30GA1 [UUC1 U40]
	Indoor unit			ZVNW24GM2H1 [UV24FH N20]
Capacity	Cooling	Min.~Rated~Max.	kW	2.70 ~ 6.80 ~ 8.30
	Heating	Min.~Rated~Max.	kW	3.00 ~ 7.50 ~ 9.40
Power Input	Cooling	Min.~Rated~Max.	kW	0.40 ~ 1.80 ~ 2.50
	Heating	Min.~Rated~Max.	kW	0.40 ~ 1.82 ~ 2.62
Running Current	Cooling	Rated	A	8.00
	Heating	Rated	A	8.10
EER / COP			W / W	3.77 / 4.11
SEER / SCOP			Wh / Wh	7.90 / 4.60
Seasonal Energy Label		Cooling / Heating	-	A++ / A++
Annual Energy Consumption		Cooling / Heating	kWh	301 / 1,644
Dehumidification Rate			ℓ/h	2.00
ODU Sound Pressure Level	Cooling	Rated	dB(A)	48
	Heating	Rated	dB(A)	52
ODU Sound Power Level	Cooling	Rated	dB(A)	65
	Heating	Rated	dB(A)	-
Piping Connections	Liquid	Outer Dia.	mm (inch)	Ø 9.52 (3/8)
	Gas	Outer Dia.	mm (inch)	Ø 15.88 (5/8)
Piping Length	Rated		m	7.5
	Min. / Max.		m	5.0 / 50.0
Refrigerant	Type		-	R32
	GWP (Global Warming Potential)		-	675
	Precharged Amount		g	1,900
	t-CO ₂ eq.		-	1.283
	Control		-	EEV
	Chargeless-Pipe Length		m	20
	Additional Charging Volume		g/m	55

Note

- Due to our policy of innovation some specifications may be changed without notification.
- Wiring cable size must comply with the applicable local and national codes. And "Electric characteristics" chapter should be considered for electrical work and design. Especially the power cable and circuit breaker should be selected in accordance with that.
- Power factor could vary less than ±1% according to the operating conditions.
- Sound pressure level is measured on the rated condition in the anechoic rooms by ISO 3745 standard.
Sound power level is measured on the rated condition in the reverberation rooms by ISO 3741 standard.
Therefore, these values can be increased owing to ambient conditions during operation.
- Performances are based on the following conditions (It is accordance with EN14511) :
 - *Cooling : Indoor Ambient Temp. 27°CDB / 19°CWB, Outdoor Ambient Temp. 35°CDB / 24°CWB
 - *Heating : Indoor Ambient Temp. 20°CDB / 15°CWB, Outdoor Ambient Temp. 7°CDB / 6°CWB
 - Interconnected Pipe is standard length and difference of Elevation (Outdoor ~ Indoor Unit) is 0m.
- This product contains Fluorinated greenhouse gases.

2. Specifications

Combination	Outdoor unit			ZUUW30GA1 [UUC1 U40]	
	Indoor unit			ZTNW30GALH1 [UT30FH NAO]	ZBNW30GM2H1 [UM30FH N20]
Capacity	Cooling	Min.~Rated~Max.	kW	3.20 ~ 8.00 ~ 9.50	3.10 ~ 7.80 ~ 9.30
	Heating	Min.~Rated~Max.	kW	3.60 ~ 9.00 ~ 10.70	3.60 ~ 9.00 ~ 10.70
Power Input	Cooling	Min.~Rated~Max.	kW	0.40 ~ 2.12 ~ 2.82	0.50 ~ 2.25 ~ 2.99
	Heating	Min.~Rated~Max.	kW	0.40 ~ 2.14 ~ 2.93	0.50 ~ 2.27 ~ 3.11
Running Current	Cooling	Rated	A	9.40	10.00
	Heating	Rated	A	9.50	10.10
EER / COP			W / W	3.77 / 4.20	3.51 / 3.97
SEER / SCOP			Wh / Wh	7.80 / 4.80	6.60 / 4.30
Seasonal Energy Label		Cooling / Heating	-	A++ / A++	A++ / A+
Annual Energy Consumption		Cooling / Heating	kWh	359 / 1,604	419 / 1,758
Dehumidification Rate			ℓ/h	2.70	2.20
ODU Sound Pressure Level	Cooling	Rated	dB(A)	50	50
	Heating	Rated	dB(A)	52	52
ODU Sound Power Level	Cooling	Rated	dB(A)	68	68
	Heating	Rated	dB(A)	-	-
Piping Connections	Liquid	Outer Dia.	mm (inch)	Ø 9.52 (3/8)	Ø 9.52 (3/8)
	Gas	Outer Dia.	mm (inch)	Ø 15.88 (5/8)	Ø 15.88 (5/8)
Piping Length	Rated		m	7.5	7.5
	Min. / Max.		m	5.0 / 50.0	5.0 / 50.0
Refrigerant	Type		-	R32	R32
	GWP (Global Warming Potential)		-	675	675
	Precharged Amount		g	1,900	1,900
	t-CO ₂ eq.		-	1.283	1.283
	Control		-	EEV	EEV
	Chargeless-Pipe Length		m	20	20
	Additional Charging Volume		g/m	55	55

Note

- Due to our policy of innovation some specifications may be changed without notification.
- Wiring cable size must comply with the applicable local and national codes. And "Electric characteristics" chapter should be considered for electrical work and design. Especially the power cable and circuit breaker should be selected in accordance with that.
- Power factor could vary less than ±1% according to the operating conditions.
- Sound pressure level is measured on the rated condition in the anechoic rooms by ISO 3745 standard.
Sound power level is measured on the rated condition in the reverberation rooms by ISO 3741 standard.
Therefore, these values can be increased owing to ambient conditions during operation.
- Performances are based on the following conditions (It is accordance with EN14511) :
 - *Cooling : Indoor Ambient Temp. 27°CDB / 19°CWB, Outdoor Ambient Temp. 35°CDB / 24°CWB
 - *Heating : Indoor Ambient Temp. 20°CDB / 15°CWB, Outdoor Ambient Temp. 7°CDB / 6°CWB
 - Interconnected Pipe is standard length and difference of Elevation (Outdoor ~ Indoor Unit) is 0m.
- This product contains Fluorinated greenhouse gases.

2. Specifications

Combination	Outdoor unit			ZUUW30GA1 [UUC1 U40]
	Indoor unit			ZVNW30GM2H1 [UV30FH N20]
Capacity	Cooling	Min.~Rated~Max.	kW	3.20 ~ 8.00 ~ 9.50
	Heating	Min.~Rated~Max.	kW	3.60 ~ 8.90 ~ 10.60
Power Input	Cooling	Min.~Rated~Max.	kW	0.50 ~ 2.35 ~ 3.13
	Heating	Min.~Rated~Max.	kW	0.50 ~ 2.39 ~ 3.27
Running Current	Cooling	Rated	A	10.40
	Heating	Rated	A	10.60
EER / COP			W / W	3.41 / 3.72
SEER / SCOP			Wh / Wh	7.20 / 4.60
Seasonal Energy Label		Cooling / Heating	-	A++ / A++
Annual Energy Consumption		Cooling / Heating	kWh	389 / 1,644
Dehumidification Rate			ℓ/h	2.80
ODU Sound Pressure Level	Cooling	Rated	dB(A)	50
	Heating	Rated	dB(A)	52
ODU Sound Power Level	Cooling	Rated	dB(A)	68
	Heating	Rated	dB(A)	-
Piping Connections	Liquid	Outer Dia.	mm (inch)	Ø 9.52 (3/8)
	Gas	Outer Dia.	mm (inch)	Ø 15.88 (5/8)
Piping Length	Rated		m	7.5
	Min. / Max.		m	5.0 / 50.0
Refrigerant	Type		-	R32
	GWP (Global Warming Potential)		-	675
	Precharged Amount		g	1,900
	t-CO ₂ eq.		-	1.283
	Control		-	EEV
	Chargeless-Pipe Length		m	20
	Additional Charging Volume		g/m	55

Note

- Due to our policy of innovation some specifications may be changed without notification.
- Wiring cable size must comply with the applicable local and national codes. And "Electric characteristics" chapter should be considered for electrical work and design. Especially the power cable and circuit breaker should be selected in accordance with that.
- Power factor could vary less than ±1% according to the operating conditions.
- Sound pressure level is measured on the rated condition in the anechoic rooms by ISO 3745 standard.
Sound power level is measured on the rated condition in the reverberation rooms by ISO 3741 standard.
Therefore, these values can be increased owing to ambient conditions during operation.
- Performances are based on the following conditions (It is accordance with EN14511) :
 - *Cooling : Indoor Ambient Temp. 27°CDB / 19°CWB, Outdoor Ambient Temp. 35°CDB / 24°CWB
 - *Heating : Indoor Ambient Temp. 20°CDB / 15°CWB, Outdoor Ambient Temp. 7°CDB / 6°CWB
 - Interconnected Pipe is standard length and difference of Elevation (Outdoor ~ Indoor Unit) is 0m.
- This product contains Fluorinated greenhouse gases.

2. Specifications

Combination	Outdoor unit			ZUUW48GA1 [UUD1 U30]	
	Indoor unit			ZTNW36GALH1 [UT36FH NAO]	ZBNW36GM3H1 [UM36FH N30]
Capacity	Cooling	Min.~Rated~Max.	kW	3.80 ~ 9.50 ~ 12.80	3.80 ~ 9.50 ~ 12.80
	Heating	Min.~Rated~Max.	kW	4.30 ~ 10.80 ~ 13.70	4.30 ~ 10.80 ~ 13.70
Power Input	Cooling	Min.~Rated~Max.	kW	0.40 ~ 2.15 ~ 3.23	0.50 ~ 2.26 ~ 3.39
	Heating	Min.~Rated~Max.	kW	0.50 ~ 2.40 ~ 3.36	0.50 ~ 2.57 ~ 3.60
Running Current	Cooling	Rated	A	9.60	10.00
	Heating	Rated	A	10.40	11.30
EER / COP			W / W	4.42 / 4.50	4.20 / 4.20
SEER / SCOP			Wh / Wh	7.60 / 4.50	6.40 / 4.20
Seasonal Energy Label		Cooling / Heating	-	A++ / A+	A++ / A+
Annual Energy Consumption		Cooling / Heating	kWh	437 / 2,956	520 / 3,167
Dehumidification Rate			ℓ/h	2.61	1.97
ODU Sound Pressure Level	Cooling	Rated	dB(A)	50	50
	Heating	Rated	dB(A)	50	50
ODU Sound Power Level	Cooling	Rated	dB(A)	66	66
	Heating	Rated	dB(A)	-	-
Piping Connections	Liquid	Outer Dia.	mm (inch)	Ø 9.52 (3/8)	Ø 9.52 (3/8)
	Gas	Outer Dia.	mm (inch)	Ø 15.88 (5/8)	Ø 15.88 (5/8)
Piping Length	Rated		m	7.5	7.5
	Min. / Max.		m	5.0 / 85.0	5.0 / 85.0
Refrigerant	Type		-	R32	R32
	GWP (Global Warming Potential)		-	675	675
	Precharged Amount		g	3,000	3,000
	t-CO ₂ eq.		-	2.025	2.025
	Control		-	EEV	EEV
	Chargeless-Pipe Length		m	20	20
	Additional Charging Volume		g/m	50	50

Note

1. Due to our policy of innovation some specifications may be changed without notification.
2. Wiring cable size must comply with the applicable local and national codes. And "Electric characteristics" chapter should be considered for electrical work and design. Especially the power cable and circuit breaker should be selected in accordance with that.
3. Power factor could vary less than ±1% according to the operating conditions.
4. Sound pressure level is measured on the rated condition in the anechoic rooms by ISO 3745 standard.
Sound power level is measured on the rated condition in the reverberation rooms by ISO 3741 standard.
Therefore, these values can be increased owing to ambient conditions during operation.
5. Performances are based on the following conditions (It is accordance with EN14511) :
 - *Cooling : Indoor Ambient Temp. 27°CDB / 19°CWB, Outdoor Ambient Temp. 35°CDB / 24°CWB
 - *Heating : Indoor Ambient Temp. 20°CDB / 15°CWB, Outdoor Ambient Temp. 7°CDB / 6°CWB
 - Interconnected Pipe is standard length and difference of Elevation (Outdoor ~ Indoor Unit) is 0m.
6. This product contains Fluorinated greenhouse gases.

2. Specifications

Combination	Outdoor unit			ZUUW48GA1 [UUD1 U30]
	Indoor unit			ZVNW36GM2H1 [UV36FH N20]
Capacity	Cooling	Min.~Rated~Max.	kW	3.80 ~ 9.50 ~ 12.80
	Heating	Min.~Rated~Max.	kW	4.30 ~ 10.80 ~ 13.70
Power Input	Cooling	Min.~Rated~Max.	kW	0.50 ~ 2.50 ~ 3.75
	Heating	Min.~Rated~Max.	kW	0.50 ~ 2.54 ~ 3.56
Running Current	Cooling	Rated	A	11.10
	Heating	Rated	A	11.40
EER / COP			W / W	3.80 / 4.25
SEER / SCOP			Wh / Wh	6.70 / 4.30
Seasonal Energy Label		Cooling / Heating	-	A++ / A+
Annual Energy Consumption		Cooling / Heating	kWh	496 / 3,093
Dehumidification Rate			ℓ/h	3.60
ODU Sound Pressure Level	Cooling	Rated	dB(A)	50
	Heating	Rated	dB(A)	50
ODU Sound Power Level	Cooling	Rated	dB(A)	66
	Heating	Rated	dB(A)	-
Piping Connections	Liquid	Outer Dia.	mm (inch)	Ø 9.52 (3/8)
	Gas	Outer Dia.	mm (inch)	Ø 15.88 (5/8)
Piping Length	Rated		m	7.5
	Min. / Max.		m	5.0 / 85.0
Refrigerant	Type		-	R32
	GWP (Global Warming Potential)		-	675
	Precharged Amount		g	3,000
	t-CO ₂ eq.		-	2.025
	Control		-	EEV
	Chargeless-Pipe Length		m	20
	Additional Charging Volume		g/m	50

Note

- Due to our policy of innovation some specifications may be changed without notification.
- Wiring cable size must comply with the applicable local and national codes. And "Electric characteristics" chapter should be considered for electrical work and design. Especially the power cable and circuit breaker should be selected in accordance with that.
- Power factor could vary less than ±1% according to the operating conditions.
- Sound pressure level is measured on the rated condition in the anechoic rooms by ISO 3745 standard.
Sound power level is measured on the rated condition in the reverberation rooms by ISO 3741 standard.
Therefore, these values can be increased owing to ambient conditions during operation.
- Performances are based on the following conditions (It is accordance with EN14511) :
 - *Cooling : Indoor Ambient Temp. 27°CDB / 19°CWB, Outdoor Ambient Temp. 35°CDB / 24°CWB
 - *Heating : Indoor Ambient Temp. 20°CDB / 15°CWB, Outdoor Ambient Temp. 7°CDB / 6°CWB
 - Interconnected Pipe is standard length and difference of Elevation (Outdoor ~ Indoor Unit) is 0m.
- This product contains Fluorinated greenhouse gases.

2. Specifications

Combination	Outdoor unit			ZUUW48GA1 [UUD1 U30]	
	Indoor unit			ZTNW42GALH1 [UT42FH NAO]	ZBNW42GM3H1 [UM42FH N30]
Capacity	Cooling	Min.~Rated~Max.	kW	4.80 ~ 12.10 ~ 14.50	4.80 ~ 12.00 ~ 14.40
	Heating	Min.~Rated~Max.	kW	5.40 ~ 13.50 ~ 16.20	5.40 ~ 13.50 ~ 16.20
Power Input	Cooling	Min.~Rated~Max.	kW	0.60 ~ 3.14 ~ 4.24	0.70 ~ 3.38 ~ 4.56
	Heating	Min.~Rated~Max.	kW	0.70 ~ 3.29 ~ 4.28	0.70 ~ 3.51 ~ 4.56
Running Current	Cooling	Rated	A	13.80	14.90
	Heating	Rated	A	14.40	15.30
EER / COP			W / W	3.85 / 4.10	3.55 / 3.85
SEER / SCOP			Wh / Wh	7.40 / 4.50	6.20 / 4.10
Seasonal Space Energy Efficiency($\eta_{s,c} / \eta_{s,h}$)			% / %	293.0 / 177.0	- / -
Seasonal Energy Label		Cooling / Heating	-	- / -	A++ / A+
Annual Energy Consumption		Cooling / Heating	kWh	981 / 2,956	677 / 3,244
Dehumidification Rate			ℓ/h	4.81	4.16
ODU Sound Pressure Level	Cooling	Rated	dB(A)	51	51
	Heating	Rated	dB(A)	52	52
ODU Sound Power Level	Cooling	Rated	dB(A)	69	69
	Heating	Rated	dB(A)	69	-
Piping Connections	Liquid	Outer Dia.	mm (inch)	Ø 9.52 (3/8)	Ø 9.52 (3/8)
	Gas	Outer Dia.	mm (inch)	Ø 15.88 (5/8)	Ø 15.88 (5/8)
Piping Length	Rated		m	7.5	7.5
	Min. / Max.		m	5.0 / 85.0	5.0 / 85.0
Refrigerant	Type		-	R32	R32
	GWP (Global Warming Potential)		-	675	675
	Precharged Amount		g	3,000	3,000
	t-CO ₂ eq.		-	2.025	2.025
	Control		-	EEV	EEV
	Chargeless-Pipe Length		m	20	20
	Additional Charging Volume		g/m	50	50

Note

- Due to our policy of innovation some specifications may be changed without notification.
- Wiring cable size must comply with the applicable local and national codes. And "Electric characteristics" chapter should be considered for electrical work and design. Especially the power cable and circuit breaker should be selected in accordance with that.
- Power factor could vary less than $\pm 1\%$ according to the operating conditions.
- Sound pressure level is measured on the rated condition in the anechoic rooms by ISO 3745 standard.
Sound power level is measured on the rated condition in the reverberation rooms by ISO 3741 standard.
Therefore, these values can be increased owing to ambient conditions during operation.
- Performances are based on the following conditions (It is accordance with EN14511) :
 - *Cooling : Indoor Ambient Temp. 27°CDB / 19°CWB, Outdoor Ambient Temp. 35°CDB / 24°CWB
 - *Heating : Indoor Ambient Temp. 20°CDB / 15°CWB, Outdoor Ambient Temp. 7°CDB / 6°CWB
 - Interconnected Pipe is standard length and difference of Elevation (Outdoor ~ Indoor Unit) is 0m.
- This product contains Fluorinated greenhouse gases.

2. Specifications

Combination	Outdoor unit			ZUUW48GA1 [UUD1 U30]
	Indoor unit			ZVNW42GM2H1 [UV42FH N20]
Capacity	Cooling	Min.~Rated~Max.	kW	4.80 ~ 12.10 ~ 14.50
	Heating	Min.~Rated~Max.	kW	5.40 ~ 13.50 ~ 16.20
Power Input	Cooling	Min.~Rated~Max.	kW	0.70 ~ 3.64 ~ 4.91
	Heating	Min.~Rated~Max.	kW	0.80 ~ 3.75 ~ 4.88
Running Current	Cooling	Rated	A	16.00
	Heating	Rated	A	16.50
EER / COP			W / W	3.32 / 3.60
SEER / SCOP			Wh / Wh	6.60 / 4.30
Seasonal Space Energy Efficiency($\eta_{s,c} / \eta_{s,h}$)			% / %	261.0 / 169.0
Seasonal Energy Label		Cooling / Heating	-	- / -
Annual Energy Consumption		Cooling / Heating	kWh	1,100/ 3,093
Dehumidification Rate			ℓ/h	5.52
ODU Sound Pressure Level	Cooling	Rated	dB(A)	51
	Heating	Rated	dB(A)	52
ODU Sound Power Level	Cooling	Rated	dB(A)	69
	Heating	Rated	dB(A)	69
Piping Connections	Liquid	Outer Dia.	mm (inch)	Ø 9.52 (3/8)
	Gas	Outer Dia.	mm (inch)	Ø 15.88 (5/8)
Piping Length		Rated	m	7.5
		Min. / Max.	m	5.0 / 85.0
Refrigerant	Type		-	R32
	GWP (Global Warming Potential)		-	675
	Precharged Amount		g	3,000
	t-CO ₂ eq.		-	2.025
	Control		-	EEV
	Chargeless-Pipe Length		m	20
	Additional Charging Volume		g/m	50

Note

- Due to our policy of innovation some specifications may be changed without notification.
- Wiring cable size must comply with the applicable local and national codes. And "Electric characteristics" chapter should be considered for electrical work and design. Especially the power cable and circuit breaker should be selected in accordance with that.
- Power factor could vary less than $\pm 1\%$ according to the operating conditions.
- Sound pressure level is measured on the rated condition in the anechoic rooms by ISO 3745 standard.
Sound power level is measured on the rated condition in the reverberation rooms by ISO 3741 standard.
Therefore, these values can be increased owing to ambient conditions during operation.
- Performances are based on the following conditions (It is accordance with EN14511) :
 - *Cooling : Indoor Ambient Temp. 27°CDB / 19°CWB, Outdoor Ambient Temp. 35°CDB / 24°CWB
 - *Heating : Indoor Ambient Temp. 20°CDB / 15°CWB, Outdoor Ambient Temp. 7°CDB / 6°CWB
 - Interconnected Pipe is standard length and difference of Elevation (Outdoor ~ Indoor Unit) is 0m.
- This product contains Fluorinated greenhouse gases.

2. Specifications

Combination	Outdoor unit			ZUUW48GA1 [UUD1 U30]	
	Indoor unit			ZTNW48GALH1 [UT48FH NAO]	ZBNW48GM3H1 [UM48FH N30]
Capacity	Cooling	Min.~Rated~Max.	kW	5.40 ~ 13.40 ~ 16.10	5.40 ~ 13.40 ~ 16.10
	Heating	Min.~Rated~Max.	kW	6.20 ~ 15.50 ~ 17.80	6.20 ~ 15.50 ~ 17.80
Power Input	Cooling	Min.~Rated~Max.	kW	0.80 ~ 3.83 ~ 5.17	0.80 ~ 4.12 ~ 5.56
	Heating	Min.~Rated~Max.	kW	0.80 ~ 4.18 ~ 5.24	0.80 ~ 4.18 ~ 5.24
Running Current	Cooling	Rated	A	16.90	18.10
	Heating	Rated	A	18.30	18.40
EER / COP			W / W	3.50 / 3.71	3.25 / 3.71
SEER / SCOP			Wh / Wh	6.80 / 4.50	6.10 / 4.10
Seasonal Space Energy Efficiency($\eta_{s,c} / \eta_{s,h}$)			% / %	269.0 / 177.0	241.0 / 161.0
Seasonal Energy Label		Cooling / Heating	-	- / -	- / -
Annual Energy Consumption		Cooling / Heating	kWh	1,182 / 2,956	1,318 / 3,244
Dehumidification Rate			l/h	5.29	4.81
ODU Sound Pressure Level	Cooling	Rated	dB(A)	52	52
	Heating	Rated	dB(A)	53	53
ODU Sound Power Level	Cooling	Rated	dB(A)	69	69
	Heating	Rated	dB(A)	69	69
Piping Connections	Liquid	Outer Dia.	mm (inch)	Ø 9.52 (3/8)	Ø 9.52 (3/8)
	Gas	Outer Dia.	mm (inch)	Ø 15.88 (5/8)	Ø 15.88 (5/8)
Piping Length	Rated		m	7.5	7.5
	Min. / Max.		m	5.0 / 85.0	5.0 / 85.0
Refrigerant	Type		-	R32	R32
	GWP (Global Warming Potential)		-	675	675
	Precharged Amount		g	3,000	3,000
	t-CO ₂ eq.		-	2.025	2.025
	Control		-	EEV	EEV
	Chargeless-Pipe Length		m	20	20
	Additional Charging Volume		g/m	50	50

Note

- Due to our policy of innovation some specifications may be changed without notification.
- Wiring cable size must comply with the applicable local and national codes. And "Electric characteristics" chapter should be considered for electrical work and design. Especially the power cable and circuit breaker should be selected in accordance with that.
- Power factor could vary less than $\pm 1\%$ according to the operating conditions.
- Sound pressure level is measured on the rated condition in the anechoic rooms by ISO 3745 standard.
Sound power level is measured on the rated condition in the reverberation rooms by ISO 3741 standard.
Therefore, these values can be increased owing to ambient conditions during operation.
- Performances are based on the following conditions (It is accordance with EN14511) :
 - *Cooling : Indoor Ambient Temp. 27°CDB / 19°CWB, Outdoor Ambient Temp. 35°CDB / 24°CWB
 - *Heating : Indoor Ambient Temp. 20°CDB / 15°CWB, Outdoor Ambient Temp. 7°CDB / 6°CWB
 - Interconnected Pipe is standard length and difference of Elevation (Outdoor ~ Indoor Unit) is 0m.
- This product contains Fluorinated greenhouse gases.

2. Specifications

Combination	Outdoor unit			ZUUW48GA1 [UUD1 U30]
	Indoor unit			ZTNW60GALH1 [UT60FH NA0]
Capacity	Cooling	Min.~Rated~Max.	kW	6.00 ~ 15.00 ~ 16.20
	Heating	Min.~Rated~Max.	kW	7.00 ~ 17.50 ~ 19.30
Power Input	Cooling	Min.~Rated~Max.	kW	0.90 ~ 4.69 ~ 5.25
	Heating	Min.~Rated~Max.	kW	1.10 ~ 5.38 ~ 6.19
Running Current	Cooling	Rated	A	20.50
	Heating	Rated	A	23.60
EER / COP			W / W	3.20 / 3.25
SEER / SCOP			Wh / Wh	6.60 / 4.50
Seasonal Space Energy Efficiency($\eta_{s,c} / \eta_{s,h}$)			% / %	261.0 / 177.0
Seasonal Energy Label		Cooling / Heating	-	- / -
Annual Energy Consumption		Cooling / Heating	kWh	1,364 / 2,956
Dehumidification Rate			ℓ/h	6.86
ODU Sound Pressure Level	Cooling	Rated	dB(A)	54
	Heating	Rated	dB(A)	54
ODU Sound Power Level	Cooling	Rated	dB(A)	71
	Heating	Rated	dB(A)	71
Piping Connections	Liquid	Outer Dia.	mm (inch)	Ø 9.52 (3/8)
	Gas	Outer Dia.	mm (inch)	Ø 15.88 (5/8)
Piping Length	Rated		m	7.5
	Min. / Max.		m	5.0 / 85.0
Refrigerant	Type		-	R32
	GWP (Global Warming Potential)		-	675
	Precharged Amount		g	3,000
	t-CO ₂ eq.		-	2.025
	Control		-	EEV
	Chargeless-Pipe Length		m	20
	Additional Charging Volume		g/m	50

Note

- Due to our policy of innovation some specifications may be changed without notification.
- Wiring cable size must comply with the applicable local and national codes. And "Electric characteristics" chapter should be considered for electrical work and design. Especially the power cable and circuit breaker should be selected in accordance with that.
- Power factor could vary less than ±1% according to the operating conditions.
- Sound pressure level is measured on the rated condition in the anechoic rooms by ISO 3745 standard.
Sound power level is measured on the rated condition in the reverberation rooms by ISO 3741 standard.
Therefore, these values can be increased owing to ambient conditions during operation.
- Performances are based on the following conditions (It is accordance with EN14511) :
 - *Cooling : Indoor Ambient Temp. 27°CDB / 19°CWB, Outdoor Ambient Temp. 35°CDB / 24°CWB
 - *Heating : Indoor Ambient Temp. 20°CDB / 15°CWB, Outdoor Ambient Temp. 7°CDB / 6°CWB
 - Interconnected Pipe is standard length and difference of Elevation (Outdoor ~ Indoor Unit) is 0m.
- This product contains Fluorinated greenhouse gases.

2. Specifications

■ H-Inverter(3 Phase Inverter)

Combination	Outdoor unit			ZUUW48LA1 [UUD3 U30]	
	Indoor unit			ZTNW36GALH1 [UT36FH NA0]	ZBNW36GM3H1 [UM36FH N30]
Capacity	Cooling	Min.~Rated~Max.	kW	3.80~ 9.50 ~ 12.80	3.80 ~ 9.50 ~ 12.80
	Heating	Min.~Rated~Max.	kW	4.30 ~ 10.80 ~ 13.70	4.30 ~ 10.80 ~ 13.70
Power Input	Cooling	Min.~Rated~Max.	kW	0.40 ~ 2.15 ~ 3.23	0.50 ~ 2.26 ~ 3.39
	Heating	Min.~Rated~Max.	kW	0.50 ~ 2.40~ 3.36	0.50 ~ 2.57~ 3.60
Running Current	Cooling	Rated	A	3.60	3.80
	Heating	Rated	A	3.80	4.10
EER / COP			W / W	4.42 / 4.50	4.20 / 4.20
SEER / SCOP			Wh / Wh	7.60 / 4.50	6.40 / 4.20
Seasonal Energy Label		Cooling / Heating	-	A++ / A+	A++ / A+
Annual Energy Consumption		Cooling / Heating	kWh	437 / 2,956	520 / 3,167
Dehumidification Rate			ℓ/h	2.61	1.97
ODU Sound Pressure Level	Cooling	Rated	dB(A)	50	50
	Heating	Rated	dB(A)	50	50
ODU Sound Power Level	Cooling	Rated	dB(A)	66	66
	Heating	Rated	dB(A)	-	-
Piping Connections	Liquid	Outer Dia.	mm (inch)	Ø 9.52 (3/8)	Ø 9.52 (3/8)
	Gas	Outer Dia.	mm (inch)	Ø 15.88 (5/8)	Ø 15.88 (5/8)
Piping Length	Rated		m	7.5	7.5
	Min. / Max.		m	5.0 / 85.0	5.0 / 85.0
Refrigerant	Type		-	R32	R32
	GWP (Global Warming Potential)		-	675	675
	Precharged Amount		g	3,000	3,000
	t-CO ₂ eq.		-	2.025	2.025
	Control		-	EEV	EEV
	Chargeless-Pipe Length		m	20	20
	Additional Charging Volume		g/m	50	50

Note

- Due to our policy of innovation some specifications may be changed without notification.
- Wiring cable size must comply with the applicable local and national codes. And "Electric characteristics" chapter should be considered for electrical work and design. Especially the power cable and circuit breaker should be selected in accordance with that.
- Power factor could vary less than ±1% according to the operating conditions.
- Sound pressure level is measured on the rated condition in the anechoic rooms by ISO 3745 standard.
Sound power level is measured on the rated condition in the reverberation rooms by ISO 3741 standard.
Therefore, these values can be increased owing to ambient conditions during operation.
- Performances are based on the following conditions (It is accordance with EN14511) :
 - *Cooling : Indoor Ambient Temp. 27°CDB / 19°CWB, Outdoor Ambient Temp. 35°CDB / 24°CWB
 - *Heating : Indoor Ambient Temp. 20°CDB / 15°CWB, Outdoor Ambient Temp. 7°CDB / 6°CWB
 - Interconnected Pipe is standard length and difference of Elevation (Outdoor ~ Indoor Unit) is 0m.
- This product contains Fluorinated greenhouse gases.

2. Specifications

Combination	Outdoor unit			ZUUW48LA1 [UUD3 U30]
	Indoor unit			ZVNW36GM2H1 [UV36FH N20]
Capacity	Cooling	Min.~Rated~Max.	kW	3.80 ~ 9.50 ~ 12.80
	Heating	Min.~Rated~Max.	kW	4.30 ~ 10.80 ~ 13.70
Power Input	Cooling	Min.~Rated~Max.	kW	0.50 ~ 2.50 ~ 3.75
	Heating	Min.~Rated~Max.	kW	0.50 ~ 2.54 ~ 3.56
Running Current	Cooling	Rated	A	4.00
	Heating	Rated	A	4.10
EER / COP			W / W	3.80 / 4.25
SEER / SCOP			Wh / Wh	6.70 / 4.30
Seasonal Energy Label		Cooling / Heating	-	A++ / A+
Annual Energy Consumption		Cooling / Heating	kWh	496 / 3,093
Dehumidification Rate			ℓ/h	3.60
ODU Sound Pressure Level	Cooling	Rated	dB(A)	50
	Heating	Rated	dB(A)	50
ODU Sound Power Level	Cooling	Rated	dB(A)	66
	Heating	Rated	dB(A)	-
Piping Connections	Liquid	Outer Dia.	mm (inch)	Ø 9.52 (3/8)
	Gas	Outer Dia.	mm (inch)	Ø 15.88 (5/8)
Piping Length	Rated		m	7.5
	Min. / Max.		m	5.0 / 85.0
Refrigerant	Type		-	R32
	GWP (Global Warming Potential)		-	675
	Precharged Amount		g	3,000
	t-CO ₂ eq.		-	2.025
	Control		-	EEV
	Chargeless-Pipe Length		m	20
	Additional Charging Volume		g/m	50

Note

- Due to our policy of innovation some specifications may be changed without notification.
- Wiring cable size must comply with the applicable local and national codes. And "Electric characteristics" chapter should be considered for electrical work and design. Especially the power cable and circuit breaker should be selected in accordance with that.
- Power factor could vary less than ±1% according to the operating conditions.
- Sound pressure level is measured on the rated condition in the anechoic rooms by ISO 3745 standard.
Sound power level is measured on the rated condition in the reverberation rooms by ISO 3741 standard.
Therefore, these values can be increased owing to ambient conditions during operation.
- Performances are based on the following conditions (It is accordance with EN14511) :
 - *Cooling : Indoor Ambient Temp. 27°CDB / 19°CWB, Outdoor Ambient Temp. 35°CDB / 24°CWB
 - *Heating : Indoor Ambient Temp. 20°CDB / 15°CWB, Outdoor Ambient Temp. 7°CDB / 6°CWB
 - Interconnected Pipe is standard length and difference of Elevation (Outdoor ~ Indoor Unit) is 0m.
- This product contains Fluorinated greenhouse gases.

2. Specifications

Combination	Outdoor unit			ZUUW48LA1 [UUD3 U30]	
	Indoor unit			ZTNW42GALH1 [UT42FH NAO]	ZBNW42GM3H1 [UM42FH N30]
Capacity	Cooling	Min.~Rated~Max.	kW	4.80 ~ 12.10 ~ 14.50	4.80 ~ 12.00 ~ 14.40
	Heating	Min.~Rated~Max.	kW	5.40 ~ 13.50 ~ 16.20	5.40 ~ 13.50 ~ 16.20
Power Input	Cooling	Min.~Rated~Max.	kW	0.60 ~ 3.14 ~ 4.24	0.70 ~ 3.38 ~ 4.56
	Heating	Min.~Rated~Max.	kW	0.70 ~ 3.29 ~ 4.28	0.70 ~ 3.51 ~ 4.56
Running Current	Cooling	Rated	A	4.90	5.30
	Heating	Rated	A	5.10	5.50
EER / COP			W / W	3.85 / 4.10	3.55 / 3.85
SEER / SCOP			Wh / Wh	7.40 / 4.50	6.20 / 4.10
Seasonal Space Energy Efficiency($\eta_{s,c} / \eta_{s,h}$)			% / %	293.0 / 177.0	- / -
Seasonal Energy Label		Cooling / Heating	-	- / -	A++ / A+
Annual Energy Consumption		Cooling / Heating	kWh	981 / 2,956	677 / 3,244
Dehumidification Rate			ℓ/h	4.81	4.16
ODU Sound Pressure Level	Cooling	Rated	dB(A)	51	51
	Heating	Rated	dB(A)	52	52
ODU Sound Power Level	Cooling	Rated	dB(A)	69	69
	Heating	Rated	dB(A)	69	-
Piping Connections	Liquid	Outer Dia.	mm (inch)	Ø 9.52 (3/8)	Ø 9.52 (3/8)
	Gas	Outer Dia.	mm (inch)	Ø 15.88 (5/8)	Ø 15.88 (5/8)
Piping Length	Rated		m	7.5	7.5
	Min. / Max.		m	5.0 / 85.0	5.0 / 85.0
Refrigerant	Type		-	R32	R32
	GWP (Global Warming Potential)		-	675	675
	Precharged Amount		g	3,000	3,000
	t-CO ₂ eq.		-	2.025	2.025
	Control		-	EEV	EEV
	Chargeless-Pipe Length		m	20	20
	Additional Charging Volume		g/m	50	50

Note

- Due to our policy of innovation some specifications may be changed without notification.
- Wiring cable size must comply with the applicable local and national codes. And "Electric characteristics" chapter should be considered for electrical work and design. Especially the power cable and circuit breaker should be selected in accordance with that.
- Power factor could vary less than $\pm 1\%$ according to the operating conditions.
- Sound pressure level is measured on the rated condition in the anechoic rooms by ISO 3745 standard.
Sound power level is measured on the rated condition in the reverberation rooms by ISO 3741 standard.
Therefore, these values can be increased owing to ambient conditions during operation.
- Performances are based on the following conditions (It is accordance with EN14511) :
 - *Cooling : Indoor Ambient Temp. 27°CDB / 19°CWB, Outdoor Ambient Temp. 35°CDB / 24°CWB
 - *Heating : Indoor Ambient Temp. 20°CDB / 15°CWB, Outdoor Ambient Temp. 7°CDB / 6°CWB
 - Interconnected Pipe is standard length and difference of Elevation (Outdoor ~ Indoor Unit) is 0m.
- This product contains Fluorinated greenhouse gases.

2. Specifications

Combination	Outdoor unit			ZUUW48LA1 [UUD3 U30]
	Indoor unit			ZVNW42GM2H1 [UV42FH N20]
Capacity	Cooling	Min.~Rated~Max.	kW	4.80 ~ 12.10 ~ 14.50
	Heating	Min.~Rated~Max.	kW	5.40 ~ 13.50 ~ 16.20
Power Input	Cooling	Min.~Rated~Max.	kW	0.70 ~ 3.64 ~ 4.91
	Heating	Min.~Rated~Max.	kW	0.80 ~ 3.75 ~ 4.88
Running Current	Cooling	Rated	A	5.70
	Heating	Rated	A	5.90
EER / COP			W / W	3.32 / 3.60
SEER / SCOP			Wh / Wh	6.60 / 4.30
Seasonal Space Energy Efficiency($\eta_{s,c} / \eta_{s,h}$)			% / %	261.0 / 169.0
Seasonal Energy Label		Cooling / Heating	-	- / -
Annual Energy Consumption		Cooling / Heating	kWh	1,100/ 3,093
Dehumidification Rate			ℓ/h	5.52
ODU Sound Pressure Level	Cooling	Rated	dB(A)	51
	Heating	Rated	dB(A)	52
ODU Sound Power Level	Cooling	Rated	dB(A)	69
	Heating	Rated	dB(A)	69
Piping Connections	Liquid	Outer Dia.	mm (inch)	Ø 9.52 (3/8)
	Gas	Outer Dia.	mm (inch)	Ø 15.88 (5/8)
Piping Length	Rated		m	7.5
	Min. / Max.		m	5.0 / 85.0
Refrigerant	Type		-	R32
	GWP (Global Warming Potential)		-	675
	Precharged Amount		g	3,000
	t-CO ₂ eq.		-	2.025
	Control		-	EEV
	Chargeless-Pipe Length		m	20
	Additional Charging Volume		g/m	50

Note

- Due to our policy of innovation some specifications may be changed without notification.
- Wiring cable size must comply with the applicable local and national codes. And "Electric characteristics" chapter should be considered for electrical work and design. Especially the power cable and circuit breaker should be selected in accordance with that.
- Power factor could vary less than $\pm 1\%$ according to the operating conditions.
- Sound pressure level is measured on the rated condition in the anechoic rooms by ISO 3745 standard.
Sound power level is measured on the rated condition in the reverberation rooms by ISO 3741 standard.
Therefore, these values can be increased owing to ambient conditions during operation.
- Performances are based on the following conditions (It is accordance with EN14511) :
 - *Cooling : Indoor Ambient Temp. 27°CDB / 19°CWB, Outdoor Ambient Temp. 35°CDB / 24°CWB
 - *Heating : Indoor Ambient Temp. 20°CDB / 15°CWB, Outdoor Ambient Temp. 7°CDB / 6°CWB
 - Interconnected Pipe is standard length and difference of Elevation (Outdoor ~ Indoor Unit) is 0m.
- This product contains Fluorinated greenhouse gases.

2. Specifications

Combination	Outdoor unit			ZUUW48LA1 [UUD3 U30]	
	Indoor unit			ZTNW48GALH1 [UT48FH NAO]	ZBNW48GM3H1 [UM48FH N30]
Capacity	Cooling	Min.~Rated~Max.	kW	5.40 ~ 13.40 ~ 16.10	5.40 ~ 13.40 ~ 16.10
	Heating	Min.~Rated~Max.	kW	6.20 ~ 15.50 ~ 17.80	6.20 ~ 15.50 ~ 17.80
Power Input	Cooling	Min.~Rated~Max.	kW	0.80 ~ 3.83 ~ 5.17	0.80 ~ 4.12 ~ 5.56
	Heating	Min.~Rated~Max.	kW	0.80 ~ 4.18 ~ 5.24	0.80 ~ 4.18 ~ 5.24
Running Current	Cooling	Rated	A	6.00	6.50
	Heating	Rated	A	6.50	6.50
EER / COP			W / W	3.50 / 3.71	3.25 / 3.71
SEER / SCOP			Wh / Wh	6.80 / 4.50	6.10 / 4.10
Seasonal Space Energy Efficiency($\eta_{s,c} / \eta_{s,h}$)			% / %	269.0 / 177.0	241.0 / 161.0
Seasonal Energy Label		Cooling / Heating	-	- / -	- / -
Annual Energy Consumption		Cooling / Heating	kWh	1,182 / 2,956	1,318 / 3,244
Dehumidification Rate			l/h	5.29	4.81
ODU Sound Pressure Level	Cooling	Rated	dB(A)	52	52
	Heating	Rated	dB(A)	53	53
ODU Sound Power Level	Cooling	Rated	dB(A)	69	69
	Heating	Rated	dB(A)	69	69
Piping Connections	Liquid	Outer Dia.	mm (inch)	Ø 9.52 (3/8)	Ø 9.52 (3/8)
	Gas	Outer Dia.	mm (inch)	Ø 15.88 (5/8)	Ø 15.88 (5/8)
Piping Length	Rated		m	7.5	7.5
	Min. / Max.		m	5.0 / 85.0	5.0 / 85.0
Refrigerant	Type		-	R32	R32
	GWP (Global Warming Potential)		-	675	675
	Precharged Amount		g	3,000	3,000
	t-CO ₂ eq.		-	2.025	2.025
	Control		-	EEV	EEV
	Chargeless-Pipe Length		m	20	20
	Additional Charging Volume		g/m	50	50

Note

- Due to our policy of innovation some specifications may be changed without notification.
- Wiring cable size must comply with the applicable local and national codes. And "Electric characteristics" chapter should be considered for electrical work and design. Especially the power cable and circuit breaker should be selected in accordance with that.
- Power factor could vary less than $\pm 1\%$ according to the operating conditions.
- Sound pressure level is measured on the rated condition in the anechoic rooms by ISO 3745 standard.
Sound power level is measured on the rated condition in the reverberation rooms by ISO 3741 standard.
Therefore, these values can be increased owing to ambient conditions during operation.
- Performances are based on the following conditions (It is accordance with EN14511) :
 - *Cooling : Indoor Ambient Temp. 27°CDB / 19°CWB, Outdoor Ambient Temp. 35°CDB / 24°CWB
 - *Heating : Indoor Ambient Temp. 20°CDB / 15°CWB, Outdoor Ambient Temp. 7°CDB / 6°CWB
 - Interconnected Pipe is standard length and difference of Elevation (Outdoor ~ Indoor Unit) is 0m.
- This product contains Fluorinated greenhouse gases.

2. Specifications

Combination	Outdoor unit			ZUUW48LA1 [UUD3 U30]
	Indoor unit			ZTNW60GALH1 [UT60FH NA0]
Capacity	Cooling	Min.~Rated~Max.	kW	6.00 ~ 15.00 ~ 16.20
	Heating	Min.~Rated~Max.	kW	7.00 ~ 17.50 ~ 19.30
Power Input	Cooling	Min.~Rated~Max.	kW	0.90 ~ 4.69 ~ 5.25
	Heating	Min.~Rated~Max.	kW	1.10 ~ 5.38 ~ 6.19
Running Current	Cooling	Rated	A	7.3
	Heating	Rated	A	8.2
EER / COP			W / W	3.20 / 3.25
SEER / SCOP			Wh / Wh	6.60 / 4.50
Seasonal Space Energy Efficiency($\eta_{s,c} / \eta_{s,h}$)			% / %	261.0 / 177.0
Seasonal Energy Label		Cooling / Heating	-	- / -
Annual Energy Consumption		Cooling / Heating	kWh	1,364 / 2,956
Dehumidification Rate			ℓ/h	6.86
ODU Sound Pressure Level	Cooling	Rated	dB(A)	54
	Heating	Rated	dB(A)	54
ODU Sound Power Level	Cooling	Rated	dB(A)	71
	Heating	Rated	dB(A)	71
Piping Connections	Liquid	Outer Dia.	mm (inch)	Ø 9.52 (3/8)
	Gas	Outer Dia.	mm (inch)	Ø 15.88 (5/8)
Piping Length	Rated		m	7.5
	Min. / Max.		m	5.0 / 85.0
Refrigerant	Type		-	R32
	GWP (Global Warming Potential)		-	675
	Precharged Amount		g	3,000
	t-CO ₂ eq.		-	2.025
	Control		-	EEV
	Chargeless-Pipe Length		m	20
	Additional Charging Volume		g/m	50

Note

- Due to our policy of innovation some specifications may be changed without notification.
- Wiring cable size must comply with the applicable local and national codes. And "Electric characteristics" chapter should be considered for electrical work and design. Especially the power cable and circuit breaker should be selected in accordance with that.
- Power factor could vary less than $\pm 1\%$ according to the operating conditions.
- Sound pressure level is measured on the rated condition in the anechoic rooms by ISO 3745 standard.
Sound power level is measured on the rated condition in the reverberation rooms by ISO 3741 standard.
Therefore, these values can be increased owing to ambient conditions during operation.
- Performances are based on the following conditions (It is accordance with EN14511) :
 - *Cooling : Indoor Ambient Temp. 27°CDB / 19°CWB, Outdoor Ambient Temp. 35°CDB / 24°CWB
 - *Heating : Indoor Ambient Temp. 20°CDB / 15°CWB, Outdoor Ambient Temp. 7°CDB / 6°CWB
 - Interconnected Pipe is standard length and difference of Elevation (Outdoor ~ Indoor Unit) is 0m.
- This product contains Fluorinated greenhouse gases.

2. Specifications

■ Standard(1 Phase Inverter)

Combination	Outdoor unit			ZUUW12GA1 [UUA1 UL0]	
	Indoor unit			ZTNW09GRLA1 [CT09F NR0]	ZBNW09GL5A1 [CL09F N50]
Capacity	Cooling	Min.~Rated~Max.	kW	1.50 ~ 2.50 ~ 3.20	1.50 ~ 2.50 ~ 3.20
	Heating	Min.~Rated~Max.	kW	1.80 ~ 3.20 ~ 3.70	1.80 ~ 3.20 ~ 4.00
Power Input	Cooling	Min.~Rated~Max.	kW	0.30 ~ 0.61 ~ 0.87	0.30 ~ 0.67 ~ 0.93
	Heating	Min.~Rated~Max.	kW	0.30 ~ 0.75 ~ 0.89	0.38 ~ 0.75 ~ 1.63
Running Current	Cooling	Rated	A	2.70	3.00
	Heating	Rated	A	3.30	3.30
EER / COP			W / W	4.10 / 4.30	3.80 / 4.30
SEER / SCOP			Wh / Wh	6.70 / 4.00	6.10 / 4.00
Seasonal Energy Label		Cooling / Heating	-	A++ / A+	A++ / A+
Annual Energy Consumption		Cooling / Heating	kWh	131 / 980	143 / 1,015
Dehumidification Rate			ℓ/h	0.63	0.19
ODU Sound Pressure Level	Cooling	Rated	dB(A)	49	49
	Heating	Rated	dB(A)	52	52
ODU Sound Power Level	Cooling	Rated	dB(A)	65	65
	Heating	Rated	dB(A)	-	-
Piping Connections	Liquid	Outer Dia.	mm (inch)	Ø 6.35 (1/4)	Ø 6.35 (1/4)
	Gas	Outer Dia.	mm (inch)	Ø 9.52 (3/8)	Ø 9.52 (3/8)
Piping Length		Rated	m	7.5	7.5
		Min. / Max.	m	5.0 / 30.0	5.0 / 30.0
Refrigerant	Type		-	R32	R32
	GWP (Global Warming Potential)		-	675	675
	Precharged Amount		g	1,000	1,000
	t-CO ₂ eq.		-	0.675	0.675
	Control		-	EEV	EEV
	Chargeless-Pipe Length		m	10	10
	Additional Charging Volume		g/m	20	20

Note

- Due to our policy of innovation some specifications may be changed without notification.
- Wiring cable size must comply with the applicable local and national codes. And "Electric characteristics" chapter should be considered for electrical work and design. Especially the power cable and circuit breaker should be selected in accordance with that.
- Power factor could vary less than ±1% according to the operating conditions.
- Sound pressure level is measured on the rated condition in the anechoic rooms by ISO 3745 standard.
Sound power level is measured on the rated condition in the reverberation rooms by ISO 3741 standard.
Therefore, these values can be increased owing to ambient conditions during operation.
- Performances are based on the following conditions (It is accordance with EN14511) :
 - *Cooling : Indoor Ambient Temp. 27°CDB / 19°CWB, Outdoor Ambient Temp. 35°CDB / 24°CWB
 - *Heating : Indoor Ambient Temp. 20°CDB / 15°CWB, Outdoor Ambient Temp. 7°CDB / 6°CWB
 - Interconnected Pipe is standard length and difference of Elevation (Outdoor ~ Indoor Unit) is 0m.
- This product contains Fluorinated greenhouse gases.

2. Specifications

Combination	Outdoor unit			ZUUW12GA1 [UUA1 UL0]	
	Indoor unit			ZQNW09GALA1 [UQ09F NA0]	ZMNW09GSJC0 [MJ09PC NSJ]
Capacity	Cooling	Min.~Rated~Max.	kW	1.50 ~ 2.60 ~ 3.40	1.50 ~ 2.50 ~ 3.20
	Heating	Min.~Rated~Max.	kW	1.60 ~ 3.10 ~ 3.90	1.80 ~ 3.20 ~ 3.70
Power Input	Cooling	Min.~Rated~Max.	kW	0.30 ~ 0.65 ~ 0.91	0.30 ~ 0.58 ~ 0.84
	Heating	Min.~Rated~Max.	kW	0.30 ~ 0.74 ~ 1.08	0.30 ~ 0.71 ~ 0.85
Running Current	Cooling	Rated	A	2.90	2.60
	Heating	Rated	A	3.30	3.20
EER / COP			W / W	4.00 / 4.20	4.30 / 4.50
SEER / SCOP			Wh / Wh	6.50 / 4.00	7.00 / 4.00
Seasonal Energy Label		Cooling / Heating	-	A++ / A+	A++ / A+
Annual Energy Consumption		Cooling / Heating	kWh	140 / 980	125 / 980
Dehumidification Rate			ℓ/h	0.66	1.90
ODU Sound Pressure Level	Cooling	Rated	dB(A)	49	49
	Heating	Rated	dB(A)	52	52
ODU Sound Power Level	Cooling	Rated	dB(A)	65	65
	Heating	Rated	dB(A)	-	-
Piping Connections	Liquid	Outer Dia.	mm (inch)	Ø 6.35 (1/4)	Ø 6.35 (1/4)
	Gas	Outer Dia.	mm (inch)	Ø 9.52 (3/8)	Ø 9.52 (3/8)
Piping Length	Rated		m	7.5	7.5
	Min. / Max.		m	5.0 / 30.0	5.0 / 30.0
Refrigerant	Type		-	R32	R32
	GWP (Global Warming Potential)		-	675	675
	Precharged Amount		g	1,000	1,000
	t-CO ₂ eq.		-	0.675	0.675
	Control		-	EEV	EEV
	Chargeless-Pipe Length		m	10	10
	Additional Charging Volume		g/m	20	20

Note

- Due to our policy of innovation some specifications may be changed without notification.
- Wiring cable size must comply with the applicable local and national codes. And "Electric characteristics" chapter should be considered for electrical work and design. Especially the power cable and circuit breaker should be selected in accordance with that.
- Power factor could vary less than ±1% according to the operating conditions.
- Sound pressure level is measured on the rated condition in the anechoic rooms by ISO 3745 standard.
Sound power level is measured on the rated condition in the reverberation rooms by ISO 3741 standard.
Therefore, these values can be increased owing to ambient conditions during operation.
- Performances are based on the following conditions (It is accordance with EN14511) :
 - *Cooling : Indoor Ambient Temp. 27°CDB / 19°CWB, Outdoor Ambient Temp. 35°CDB / 24°CWB
 - *Heating : Indoor Ambient Temp. 20°CDB / 15°CWB, Outdoor Ambient Temp. 7°CDB / 6°CWB
 - Interconnected Pipe is standard length and difference of Elevation (Outdoor ~ Indoor Unit) is 0m.
- This product contains Fluorinated greenhouse gases.

2. Specifications

Combination	Outdoor unit			ZUUW12GA1 [UUA1 UL0]	
	Indoor unit			ZTNW12GRLA1 [CT12F NR0]	ZBNW12GL5A1 [CL12F N50]
Capacity	Cooling	Min.~Rated~Max.	kW	1.50 ~ 3.40 ~ 4.50	1.50 ~ 3.40 ~ 4.70
	Heating	Min.~Rated~Max.	kW	1.80 ~ 4.10 ~ 5.00	1.80 ~ 4.00 ~ 4.90
Power Input	Cooling	Min.~Rated~Max.	kW	0.30 ~ 0.97 ~ 1.62	0.33 ~ 1.05 ~ 1.84
	Heating	Min.~Rated~Max.	kW	0.30 ~ 1.11 ~ 1.57	0.33 ~ 1.08 ~ 1.63
Running Current	Cooling	Rated	A	4.40	4.70
	Heating	Rated	A	4.90	4.80
EER / COP			W / W	3.51 / 3.71	3.23 / 3.71
SEER / SCOP			Wh / Wh	6.70 / 4.00	5.60 / 3.80
Seasonal Energy Label		Cooling / Heating	-	A++ / A+	A+ / A
Annual Energy Consumption		Cooling / Heating	kWh	178 / 980	213 / 1,068
Dehumidification Rate			ℓ/h	1.26	0.78
ODU Sound Pressure Level	Cooling	Rated	dB(A)	49	49
	Heating	Rated	dB(A)	52	52
ODU Sound Power Level	Cooling	Rated	dB(A)	65	65
	Heating	Rated	dB(A)	-	-
Piping Connections	Liquid	Outer Dia.	mm (inch)	Ø 6.35 (1/4)	Ø 6.35 (1/4)
	Gas	Outer Dia.	mm (inch)	Ø 9.52 (3/8)	Ø 9.52 (3/8)
Piping Length	Rated		m	7.5	7.5
	Min. / Max.		m	5.0 / 30.0	5.0 / 30.0
Refrigerant	Type		-	R32	R32
	GWP (Global Warming Potential)		-	675	675
	Precharged Amount		g	1,000	1,000
	t-CO ₂ eq.		-	0.675	0.675
	Control		-	EEV	EEV
	Chargeless-Pipe Length		m	10	10
	Additional Charging Volume		g/m	20	20

Note

- Due to our policy of innovation some specifications may be changed without notification.
- Wiring cable size must comply with the applicable local and national codes. And "Electric characteristics" chapter should be considered for electrical work and design. Especially the power cable and circuit breaker should be selected in accordance with that.
- Power factor could vary less than ±1% according to the operating conditions.
- Sound pressure level is measured on the rated condition in the anechoic rooms by ISO 3745 standard.
Sound power level is measured on the rated condition in the reverberation rooms by ISO 3741 standard.
Therefore, these values can be increased owing to ambient conditions during operation.
- Performances are based on the following conditions (It is accordance with EN14511) :
 - *Cooling : Indoor Ambient Temp. 27°CDB / 19°CWB, Outdoor Ambient Temp. 35°CDB / 24°CWB
 - *Heating : Indoor Ambient Temp. 20°CDB / 15°CWB, Outdoor Ambient Temp. 7°CDB / 6°CWB
 - Interconnected Pipe is standard length and difference of Elevation (Outdoor ~ Indoor Unit) is 0m.
- This product contains Fluorinated greenhouse gases.

2. Specifications

Combination	Outdoor unit			ZUUW12GA1 [UUA1 UL0]	
	Indoor unit			ZQNW12GALA1 [UQ12F NA0]	ZMNW12GSJC0 [MJ12PC NSJ]
Capacity	Cooling	Min.~Rated~Max.	kW	1.50 ~ 3.50 ~ 4.00	1.50 ~ 3.50 ~ 4.00
	Heating	Min.~Rated~Max.	kW	1.60 ~ 4.00 ~ 4.30	1.80 ~ 4.00 ~ 4.40
Power Input	Cooling	Min.~Rated~Max.	kW	0.30 ~ 1.00 ~ 1.46	0.33 ~ 0.97 ~ 1.48
	Heating	Min.~Rated~Max.	kW	0.30 ~ 1.05 ~ 1.58	0.33 ~ 1.00 ~ 1.48
Running Current	Cooling	Rated	A	4.40	4.40
	Heating	Rated	A	4.70	4.50
EER / COP			W / W	3.50 / 3.80	3.60 / 4.00
SEER / SCOP			Wh / Wh	6.40 / 4.00	6.60 / 4.00
Seasonal Energy Label		Cooling / Heating	-	A++ / A+	A++ / A+
Annual Energy Consumption		Cooling / Heating	kWh	191 / 1,050	186 / 980
Dehumidification Rate			ℓ/h	1.27	1.90
ODU Sound Pressure Level	Cooling	Rated	dB(A)	49	49
	Heating	Rated	dB(A)	52	52
ODU Sound Power Level	Cooling	Rated	dB(A)	65	65
	Heating	Rated	dB(A)	-	-
Piping Connections	Liquid	Outer Dia.	mm (inch)	Ø 6.35 (1/4)	Ø 6.35 (1/4)
	Gas	Outer Dia.	mm (inch)	Ø 9.52 (3/8)	Ø 9.52 (3/8)
Piping Length	Rated		m	7.5	7.5
	Min. / Max.		m	5.0 / 30.0	5.0 / 30.0
Refrigerant	Type		-	R32	R32
	GWP (Global Warming Potential)		-	675	675
	Precharged Amount		g	1,000	1,000
	t-CO ₂ eq.		-	0.675	0.675
	Control		-	EEV	EEV
	Chargeless-Pipe Length		m	10	10
	Additional Charging Volume		g/m	20	20

Note

- Due to our policy of innovation some specifications may be changed without notification.
- Wiring cable size must comply with the applicable local and national codes. And "Electric characteristics" chapter should be considered for electrical work and design. Especially the power cable and circuit breaker should be selected in accordance with that.
- Power factor could vary less than ±1% according to the operating conditions.
- Sound pressure level is measured on the rated condition in the anechoic rooms by ISO 3745 standard.
Sound power level is measured on the rated condition in the reverberation rooms by ISO 3741 standard.
Therefore, these values can be increased owing to ambient conditions during operation.
- Performances are based on the following conditions (It is accordance with EN14511) :
 - *Cooling : Indoor Ambient Temp. 27°CDB / 19°CWB, Outdoor Ambient Temp. 35°CDB / 24°CWB
 - *Heating : Indoor Ambient Temp. 20°CDB / 15°CWB, Outdoor Ambient Temp. 7°CDB / 6°CWB
 - Interconnected Pipe is standard length and difference of Elevation (Outdoor ~ Indoor Unit) is 0m.
- This product contains Fluorinated greenhouse gases.

2. Specifications

Combination	Outdoor unit			ZUUW24GA1 [UUB1 U20]	
	Indoor unit			ZTNW18GQLA1 [CT18F NQ0]	ZBNW18GM1A2 [CM18F N11]
Capacity	Cooling	Min.~Rated~Max.	kW	2.00 ~ 5.00 ~ 5.80	2.00 ~ 5.00 ~ 5.80
	Heating	Min.~Rated~Max.	kW	2.30 ~ 5.70 ~ 6.60	2.30 ~ 5.80 ~ 6.70
Power Input	Cooling	Min.~Rated~Max.	kW	0.30 ~ 1.57 ~ 2.20	0.30 ~ 1.33 ~ 1.86
	Heating	Min.~Rated~Max.	kW	0.30 ~ 1.52 ~ 2.13	0.40 ~ 1.76 ~ 2.46
Running Current	Cooling	Rated	A	8.00	7.40
	Heating	Rated	A	7.80	8.30
EER / COP			W / W	3.19 / 3.74	3.75 / 3.30
SEER / SCOP			Wh / Wh	6.40 / 4.30	6.40 / 4.10
Seasonal Energy Label		Cooling / Heating	-	A++ / A+	A++ / A+
Annual Energy Consumption		Cooling / Heating	kWh	273 / 1,335	273 / 1,400
Dehumidification Rate			ℓ/h	1.89	1.24
ODU Sound Pressure Level	Cooling	Rated	dB(A)	47	47
	Heating	Rated	dB(A)	52	52
ODU Sound Power Level	Cooling	Rated	dB(A)	63	63
	Heating	Rated	dB(A)	-	-
Piping Connections	Liquid	Outer Dia.	mm (inch)	Ø 6.35 (1/4)	Ø 6.35 (1/4)
	Gas	Outer Dia.	mm (inch)	Ø 12.7 (1/2)	Ø 12.7 (1/2)
Piping Length	Rated		m	7.5	7.5
	Min. / Max.		m	5.0 / 30.0	5.0 / 30.0
Refrigerant	Type		-	R32	R32
	GWP (Global Warming Potential)		-	675	675
	Precharged Amount		g	1,200	1,200
	t-CO ₂ eq.		-	0.810	0.810
	Control		-	EEV	EEV
	Chargeless-Pipe Length		m	10	10
	Additional Charging Volume		g/m	20	20

Note

- Due to our policy of innovation some specifications may be changed without notification.
- Wiring cable size must comply with the applicable local and national codes. And "Electric characteristics" chapter should be considered for electrical work and design. Especially the power cable and circuit breaker should be selected in accordance with that.
- Power factor could vary less than ±1% according to the operating conditions.
- Sound pressure level is measured on the rated condition in the anechoic rooms by ISO 3745 standard.
Sound power level is measured on the rated condition in the reverberation rooms by ISO 3741 standard.
Therefore, these values can be increased owing to ambient conditions during operation.
- Performances are based on the following conditions (It is accordance with EN14511) :
 - *Cooling : Indoor Ambient Temp. 27°CDB / 19°CWB, Outdoor Ambient Temp. 35°CDB / 24°CWB
 - *Heating : Indoor Ambient Temp. 20°CDB / 15°CWB, Outdoor Ambient Temp. 7°CDB / 6°CWB
 - Interconnected Pipe is standard length and difference of Elevation (Outdoor ~ Indoor Unit) is 0m.
- This product contains Fluorinated greenhouse gases.

2. Specifications

Combination	Outdoor unit			ZUUW24GA1 [UUB1 U20]
	Indoor unit			ZBNW18GMAA0 [CM18F NA0]
Capacity	Cooling	Min.~Rated~Max.	kW	2.00 ~ 5.00 ~ 5.70
	Heating	Min.~Rated~Max.	kW	2.30 ~ 5.50 ~ 6.50
Power Input	Cooling	Min.~Rated~Max.	kW	0.30 ~ 1.33 ~ 1.86
	Heating	Min.~Rated~Max.	kW	0.40 ~ 1.48 ~ 2.46
Running Current	Cooling	Rated	A	7.40
	Heating	Rated	A	7.80
EER / COP			W / W	3.75 / 3.71
SEER / SCOP			Wh / Wh	6.20 / 4.10
Seasonal Energy Label		Cooling / Heating	-	A++ / A+
Annual Energy Consumption		Cooling / Heating	kWh	282 / 1,400
Dehumidification Rate			ℓ/h	1.25
ODU Sound Pressure Level	Cooling	Rated	dB(A)	47
	Heating	Rated	dB(A)	52
ODU Sound Power Level	Cooling	Rated	dB(A)	63
	Heating	Rated	dB(A)	-
Piping Connections	Liquid	Outer Dia.	mm (inch)	Ø 6.35 (1/4)
	Gas	Outer Dia.	mm (inch)	Ø 12.7 (1/2)
Piping Length	Rated		m	7.5
	Min. / Max.		m	5.0 / 30.0
Refrigerant	Type		-	R32
	GWP (Global Warming Potential)		-	675
	Precharged Amount		g	1,200
	t-CO ₂ eq.		-	0.810
	Control		-	EEV
	Chargeless-Pipe Length		m	10
	Additional Charging Volume		g/m	20

Note

- Due to our policy of innovation some specifications may be changed without notification.
- Wiring cable size must comply with the applicable local and national codes. And "Electric characteristics" chapter should be considered for electrical work and design. Especially the power cable and circuit breaker should be selected in accordance with that.
- Power factor could vary less than ±1% according to the operating conditions.
- Sound pressure level is measured on the rated condition in the anechoic rooms by ISO 3745 standard.
Sound power level is measured on the rated condition in the reverberation rooms by ISO 3741 standard.
Therefore, these values can be increased owing to ambient conditions during operation.
- Performances are based on the following conditions (It is accordance with EN14511) :
 - *Cooling : Indoor Ambient Temp. 27°CDB / 19°CWB, Outdoor Ambient Temp. 35°CDB / 24°CWB
 - *Heating : Indoor Ambient Temp. 20°CDB / 15°CWB, Outdoor Ambient Temp. 7°CDB / 6°CWB
 - Interconnected Pipe is standard length and difference of Elevation (Outdoor ~ Indoor Unit) is 0m.
- This product contains Fluorinated greenhouse gases.

2. Specifications

Combination	Outdoor unit			ZUUW24GA1 [UUB1 U20]	
	Indoor unit			ZBNW18GL6A1 [CL18F N60]	ZVNW18GM1A1 [UV18F N10]
Capacity	Cooling	Min.~Rated~Max.	kW	2.00 ~ 5.00 ~ 5.80	2.00 ~ 5.00 ~ 5.80
	Heating	Min.~Rated~Max.	kW	2.30 ~ 5.80 ~ 6.70	2.30 ~ 5.80 ~ 6.70
Power Input	Cooling	Min.~Rated~Max.	kW	0.30 ~ 1.35 ~ 1.89	0.30 ~ 1.33 ~ 1.86
	Heating	Min.~Rated~Max.	kW	0.40 ~ 1.77 ~ 2.48	0.40 ~ 1.76 ~ 2.46
Running Current	Cooling	Rated	A	7.50	7.50
	Heating	Rated	A	8.30	8.30
EER / COP			W / W	3.71 / 3.28	3.75 / 3.29
SEER / SCOP			Wh / Wh	6.10 / 3.90	6.60 / 4.30
Seasonal Energy Label		Cooling / Heating	-	A++ / A	A++ / A+
Annual Energy Consumption		Cooling / Heating	kWh	287 / 1,472	265 / 1,368
Dehumidification Rate			ℓ/h	1.64	1.80
ODU Sound Pressure Level	Cooling	Rated	dB(A)	47	47
	Heating	Rated	dB(A)	52	52
ODU Sound Power Level	Cooling	Rated	dB(A)	63	63
	Heating	Rated	dB(A)	-	-
Piping Connections	Liquid	Outer Dia.	mm (inch)	Ø 6.35 (1/4)	Ø 6.35 (1/4)
	Gas	Outer Dia.	mm (inch)	Ø 12.7 (1/2)	Ø 12.7 (1/2)
Piping Length	Rated		m	7.5	7.5
	Min. / Max.		m	5.0 / 30.0	5.0 / 30.0
Refrigerant	Type		-	R32	R32
	GWP (Global Warming Potential)		-	675	675
	Precharged Amount		g	1,200	1,200
	t-CO ₂ eq.		-	0.810	0.810
	Control		-	EEV	EEV
	Chargeless-Pipe Length		m	10	10
	Additional Charging Volume		g/m	20	20

Note

- Due to our policy of innovation some specifications may be changed without notification.
- Wiring cable size must comply with the applicable local and national codes. And "Electric characteristics" chapter should be considered for electrical work and design. Especially the power cable and circuit breaker should be selected in accordance with that.
- Power factor could vary less than ±1% according to the operating conditions.
- Sound pressure level is measured on the rated condition in the anechoic rooms by ISO 3745 standard.
Sound power level is measured on the rated condition in the reverberation rooms by ISO 3741 standard.
Therefore, these values can be increased owing to ambient conditions during operation.
- Performances are based on the following conditions (It is accordance with EN14511) :
 - *Cooling : Indoor Ambient Temp. 27°CDB / 19°CWB, Outdoor Ambient Temp. 35°CDB / 24°CWB
 - *Heating : Indoor Ambient Temp. 20°CDB / 15°CWB, Outdoor Ambient Temp. 7°CDB / 6°CWB
 - Interconnected Pipe is standard length and difference of Elevation (Outdoor ~ Indoor Unit) is 0m.
- This product contains Fluorinated greenhouse gases.

2. Specifications

Combination	Outdoor unit			ZUUW24GA1 [UUB1 U20]	
	Indoor unit			ZQNW18GALA1 [UQ18F NA0]	ZMNW18GSKC0 [MJ18PC NSK]
Capacity	Cooling	Min.~Rated~Max.	kW	2.00 ~ 5.00 ~ 5.80	2.00 ~ 5.00 ~ 5.75
	Heating	Min.~Rated~Max.	kW	2.00 ~ 4.90 ~ 5.40	2.30 ~ 5.80 ~ 6.10
Power Input	Cooling	Min.~Rated~Max.	kW	0.40 ~ 1.75 ~ 2.45	0.30 ~ 1.39 ~ 2.00
	Heating	Min.~Rated~Max.	kW	0.30 ~ 1.56 ~ 2.11	0.30 ~ 1.71 ~ 1.96
Running Current	Cooling	Rated	A	8.30	6.30
	Heating	Rated	A	8.00	7.70
EER / COP			W / W	2.85 / 3.14	3.61 / 3.40
SEER / SCOP			Wh / Wh	5.80 / 3.80	6.80 / 4.00
Seasonal Energy Label		Cooling / Heating	-	A+ / A	A++ / A+
Annual Energy Consumption		Cooling / Heating	kWh	302 / 1,396	257 / 1,365
Dehumidification Rate			ℓ/h	2.37	3.35
ODU Sound Pressure Level	Cooling	Rated	dB(A)	47	47
	Heating	Rated	dB(A)	52	52
ODU Sound Power Level	Cooling	Rated	dB(A)	63	63
	Heating	Rated	dB(A)	-	-
Piping Connections	Liquid	Outer Dia.	mm (inch)	Ø 6.35 (1/4)	Ø 6.35 (1/4)
	Gas	Outer Dia.	mm (inch)	Ø 12.7 (1/2)	Ø 12.7 (1/2)
Piping Length	Rated		m	7.5	7.5
	Min. / Max.		m	5.0 / 30.0	5.0 / 30.0
Refrigerant	Type		-	R32	R32
	GWP (Global Warming Potential)		-	675	675
	Precharged Amount		g	1,200	1,200
	t-CO ₂ eq.		-	0.810	0.810
	Control		-	EEV	EEV
	Chargeless-Pipe Length		m	10	10
	Additional Charging Volume		g/m	20	20

Note

- Due to our policy of innovation some specifications may be changed without notification.
- Wiring cable size must comply with the applicable local and national codes. And "Electric characteristics" chapter should be considered for electrical work and design. Especially the power cable and circuit breaker should be selected in accordance with that.
- Power factor could vary less than ±1% according to the operating conditions.
- Sound pressure level is measured on the rated condition in the anechoic rooms by ISO 3745 standard.
Sound power level is measured on the rated condition in the reverberation rooms by ISO 3741 standard.
Therefore, these values can be increased owing to ambient conditions during operation.
- Performances are based on the following conditions (It is accordance with EN14511) :
 - *Cooling : Indoor Ambient Temp. 27°CDB / 19°CWB, Outdoor Ambient Temp. 35°CDB / 24°CWB
 - *Heating : Indoor Ambient Temp. 20°CDB / 15°CWB, Outdoor Ambient Temp. 7°CDB / 6°CWB
 - Interconnected Pipe is standard length and difference of Elevation (Outdoor ~ Indoor Unit) is 0m.
- This product contains Fluorinated greenhouse gases.

2. Specifications

Combination	Outdoor unit			ZUUW30GA1 [UUC1 U40]	
	Indoor unit			ZTNW24GBLA1 [CT24F NB0]	ZBNW24GM1A2 [CM24F N11]
Capacity	Cooling	Min.~Rated~Max.	kW	2.70 ~ 6.80 ~ 8.00	2.70 ~ 6.80 ~ 8.00
	Heating	Min.~Rated~Max.	kW	3.00 ~ 7.50 ~ 9.00	3.00 ~ 7.50 ~ 9.00
Power Input	Cooling	Min.~Rated~Max.	kW	0.40 ~ 1.93 ~ 2.66	0.40 ~ 1.95 ~ 2.69
	Heating	Min.~Rated~Max.	kW	0.40 ~ 1.96 ~ 2.84	0.50 ~ 2.27 ~ 3.29
Running Current	Cooling	Rated	A	8.60	8.70
	Heating	Rated	A	8.70	10.10
EER / COP			W / W	3.52 / 3.83	3.49 / 3.31
SEER / SCOP			Wh / Wh	7.40 / 4.30	6.60 / 3.90
Seasonal Energy Label		Cooling / Heating	-	A++ / A+	A++ / A
Annual Energy Consumption		Cooling / Heating	kWh	322 / 1,823	361 / 1,938
Dehumidification Rate			ℓ/h	2.80	2.60
ODU Sound Pressure Level	Cooling	Rated	dB(A)	48	48
	Heating	Rated	dB(A)	52	52
ODU Sound Power Level	Cooling	Rated	dB(A)	65	65
	Heating	Rated	dB(A)	-	-
Piping Connections	Liquid	Outer Dia.	mm (inch)	Ø 9.52 (3/8)	Ø 9.52 (3/8)
	Gas	Outer Dia.	mm (inch)	Ø 15.88 (5/8)	Ø 15.88 (5/8)
Piping Length	Rated		m	7.5	7.5
	Min. / Max.		m	5.0 / 50.0	5.0 / 50.0
Refrigerant	Type		-	R32	R32
	GWP (Global Warming Potential)		-	675	675
	Precharged Amount		g	1,900	1,900
	t-CO ₂ eq.		-	1.283	1.283
	Control		-	EEV	EEV
	Chargeless-Pipe Length		m	20	20
	Additional Charging Volume		g/m	55	55

Note

- Due to our policy of innovation some specifications may be changed without notification.
- Wiring cable size must comply with the applicable local and national codes. And "Electric characteristics" chapter should be considered for electrical work and design. Especially the power cable and circuit breaker should be selected in accordance with that.
- Power factor could vary less than ±1% according to the operating conditions.
- Sound pressure level is measured on the rated condition in the anechoic rooms by ISO 3745 standard.
Sound power level is measured on the rated condition in the reverberation rooms by ISO 3741 standard.
Therefore, these values can be increased owing to ambient conditions during operation.
- Performances are based on the following conditions (It is accordance with EN14511) :
 - *Cooling : Indoor Ambient Temp. 27°CDB / 19°CWB, Outdoor Ambient Temp. 35°CDB / 24°CWB
 - *Heating : Indoor Ambient Temp. 20°CDB / 15°CWB, Outdoor Ambient Temp. 7°CDB / 6°CWB
 - Interconnected Pipe is standard length and difference of Elevation (Outdoor ~ Indoor Unit) is 0m.
- This product contains Fluorinated greenhouse gases.

2. Specifications

Combination	Outdoor unit			ZUUW30GA1 [UUC1 U40]
	Indoor unit			ZBNW24GMAA0 [CM24F NA0]
Capacity	Cooling	Min.~Rated~Max.	kW	2.70 ~ 6.80 ~ 7.80
	Heating	Min.~Rated~Max.	kW	3.00 ~ 7.50 ~ 8.50
Power Input	Cooling	Min.~Rated~Max.	kW	0.40 ~ 1.95 ~ 2.69
	Heating	Min.~Rated~Max.	kW	0.50 ~ 2.27 ~ 3.29
Running Current	Cooling	Rated	A	8.70
	Heating	Rated	A	10.10
EER / COP			W / W	3.49 / 3.31
SEER / SCOP			Wh / Wh	6.30 / 3.80
Seasonal Energy Label		Cooling / Heating	-	A++ / A
Annual Energy Consumption		Cooling / Heating	kWh	378 / 1,989
Dehumidification Rate			ℓ/h	2.60
ODU Sound Pressure Level	Cooling	Rated	dB(A)	48
	Heating	Rated	dB(A)	52
ODU Sound Power Level	Cooling	Rated	dB(A)	65
	Heating	Rated	dB(A)	-
Piping Connections	Liquid	Outer Dia.	mm (inch)	Ø 9.52 (3/8)
	Gas	Outer Dia.	mm (inch)	Ø 15.88 (5/8)
Piping Length	Rated		m	7.5
	Min. / Max.		m	5.0 / 50.0
Refrigerant	Type		-	R32
	GWP (Global Warming Potential)		-	675
	Precharged Amount		g	1,900
	t-CO ₂ eq.		-	1.283
	Control		-	EEV
	Chargeless-Pipe Length		m	20
	Additional Charging Volume		g/m	55

Note

- Due to our policy of innovation some specifications may be changed without notification.
- Wiring cable size must comply with the applicable local and national codes. And "Electric characteristics" chapter should be considered for electrical work and design. Especially the power cable and circuit breaker should be selected in accordance with that.
- Power factor could vary less than ±1% according to the operating conditions.
- Sound pressure level is measured on the rated condition in the anechoic rooms by ISO 3745 standard.
Sound power level is measured on the rated condition in the reverberation rooms by ISO 3741 standard.
Therefore, these values can be increased owing to ambient conditions during operation.
- Performances are based on the following conditions (It is accordance with EN14511) :
 - *Cooling : Indoor Ambient Temp. 27°CDB / 19°CWB, Outdoor Ambient Temp. 35°CDB / 24°CWB
 - *Heating : Indoor Ambient Temp. 20°CDB / 15°CWB, Outdoor Ambient Temp. 7°CDB / 6°CWB
 - Interconnected Pipe is standard length and difference of Elevation (Outdoor ~ Indoor Unit) is 0m.
- This product contains Fluorinated greenhouse gases.

2. Specifications

Combination	Outdoor unit			ZUUW30GA1 [UUC1 U40]	
	Indoor unit			ZBNW24GL3A1 [CL24F N30]	ZVNW24GM1A1 [UV24F N10]
Capacity	Cooling	Min.~Rated~Max.	kW	2.70 ~ 6.80 ~ 7.80	2.70 ~ 6.70 ~ 8.00
	Heating	Min.~Rated~Max.	kW	3.00 ~ 7.50 ~ 9.00	3.00 ~ 7.50 ~ 9.00
Power Input	Cooling	Min.~Rated~Max.	kW	0.40 ~ 2.03 ~ 2.84	0.40 ~ 1.99 ~ 2.69
	Heating	Min.~Rated~Max.	kW	0.40 ~ 2.13 ~ 3.30	0.40 ~ 2.20 ~ 3.08
Running Current	Cooling	Rated	A	9.00	8.80
	Heating	Rated	A	9.40	9.80
EER / COP			W / W	3.35 / 3.52	3.37 / 3.41
SEER / SCOP			Wh / Wh	6.20 / 3.90	7.20 / 4.20
Seasonal Energy Label		Cooling / Heating	-	A++ / A	A++ / A+
Annual Energy Consumption		Cooling / Heating	kWh	384 / 1,938	326 / 1,633
Dehumidification Rate			ℓ/h	2.50	2.70
ODU Sound Pressure Level	Cooling	Rated	dB(A)	48	48
	Heating	Rated	dB(A)	52	52
ODU Sound Power Level	Cooling	Rated	dB(A)	65	65
	Heating	Rated	dB(A)	-	-
Piping Connections	Liquid	Outer Dia.	mm (inch)	Ø 9.52 (3/8)	Ø 9.52 (3/8)
	Gas	Outer Dia.	mm (inch)	Ø 15.88 (5/8)	Ø 15.88 (5/8)
Piping Length	Rated		m	7.5	7.5
	Min. / Max.		m	5.0 / 50.0	5.0 / 50.0
Refrigerant	Type		-	R32	R32
	GWP (Global Warming Potential)		-	675	675
	Precharged Amount		g	1,900	1,900
	t-CO ₂ eq.		-	1.283	1.283
	Control		-	EEV	EEV
	Chargeless-Pipe Length		m	20	20
	Additional Charging Volume		g/m	55	55

Note

- Due to our policy of innovation some specifications may be changed without notification.
- Wiring cable size must comply with the applicable local and national codes. And "Electric characteristics" chapter should be considered for electrical work and design. Especially the power cable and circuit breaker should be selected in accordance with that.
- Power factor could vary less than ±1% according to the operating conditions.
- Sound pressure level is measured on the rated condition in the anechoic rooms by ISO 3745 standard.
Sound power level is measured on the rated condition in the reverberation rooms by ISO 3741 standard.
Therefore, these values can be increased owing to ambient conditions during operation.
- Performances are based on the following conditions (It is accordance with EN14511) :
 - *Cooling : Indoor Ambient Temp. 27°CDB / 19°CWB, Outdoor Ambient Temp. 35°CDB / 24°CWB
 - *Heating : Indoor Ambient Temp. 20°CDB / 15°CWB, Outdoor Ambient Temp. 7°CDB / 6°CWB
 - Interconnected Pipe is standard length and difference of Elevation (Outdoor ~ Indoor Unit) is 0m.
- This product contains Fluorinated greenhouse gases.

2. Specifications

Combination	Outdoor unit			ZUUW30GA1 [UUC1 U40]
	Indoor unit			ZMNW24GSKC0 [MJ24PC NSK]
Capacity	Cooling	Min.~Rated~Max.	kW	2.70 ~ 6.80 ~ 7.70
	Heating	Min.~Rated~Max.	kW	3.00 ~ 6.90 ~ 7.24
Power Input	Cooling	Min.~Rated~Max.	kW	0.40 ~ 2.00 ~ 2.57
	Heating	Min.~Rated~Max.	kW	0.40 ~ 2.33 ~ 2.50
Running Current	Cooling	Rated	A	9.10
	Heating	Rated	A	10.60
EER / COP			W / W	3.40 / 3.00
SEER / SCOP			Wh / Wh	6.70 / 3.90
Seasonal Energy Label		Cooling / Heating	-	A++ / A
Annual Energy Consumption		Cooling / Heating	kWh	355 / 1,795
Dehumidification Rate			ℓ/h	3.50
ODU Sound Pressure Level	Cooling	Rated	dB(A)	48
	Heating	Rated	dB(A)	52
ODU Sound Power Level	Cooling	Rated	dB(A)	65
	Heating	Rated	dB(A)	-
Piping Connections	Liquid	Outer Dia.	mm (inch)	Ø 9.52 (3/8)
	Gas	Outer Dia.	mm (inch)	Ø 15.88 (5/8)
Piping Length	Rated		m	7.5
	Min. / Max.		m	5.0 / 50.0
Refrigerant	Type		-	R32
	GWP (Global Warming Potential)		-	675
	Precharged Amount		g	1,900
	t-CO ₂ eq.		-	1.283
	Control		-	EEV
	Chargeless-Pipe Length		m	20
	Additional Charging Volume		g/m	55

Note

- Due to our policy of innovation some specifications may be changed without notification.
- Wiring cable size must comply with the applicable local and national codes. And "Electric characteristics" chapter should be considered for electrical work and design. Especially the power cable and circuit breaker should be selected in accordance with that.
- Power factor could vary less than ±1% according to the operating conditions.
- Sound pressure level is measured on the rated condition in the anechoic rooms by ISO 3745 standard.
Sound power level is measured on the rated condition in the reverberation rooms by ISO 3741 standard.
Therefore, these values can be increased owing to ambient conditions during operation.
- Performances are based on the following conditions (It is accordance with EN14511) :
 - *Cooling : Indoor Ambient Temp. 27°CDB / 19°CWB, Outdoor Ambient Temp. 35°CDB / 24°CWB
 - *Heating : Indoor Ambient Temp. 20°CDB / 15°CWB, Outdoor Ambient Temp. 7°CDB / 6°CWB
 - Interconnected Pipe is standard length and difference of Elevation (Outdoor ~ Indoor Unit) is 0m.
- This product contains Fluorinated greenhouse gases.

2. Specifications

Combination	Outdoor unit			ZUUW30GA1 [UUC1 U40]	
	Indoor unit			ZJNW30GRLA1 [US30F NR0]	ZTNW30GBLA1 [UT30F NB0]
Capacity	Cooling	Min.~Rated~Max.	kW	3.20 ~ 8.00 ~ 9.00	3.20 ~ 8.00 ~ 9.20
	Heating	Min.~Rated~Max.	kW	3.60 ~ 9.00 ~ 10.00	3.60 ~ 8.90 ~ 10.10
Power Input	Cooling	Min.~Rated~Max.	kW	0.50 ~ 2.28 ~ 3.17	0.50 ~ 2.45 ~ 3.14
	Heating	Min.~Rated~Max.	kW	0.50 ~ 2.50 ~ 3.20	0.50 ~ 2.62 ~ 3.25
Running Current	Cooling	Rated	A	10.10	10.90
	Heating	Rated	A	11.10	11.60
EER / COP			W / W	3.51 / 3.60	3.27 / 3.40
SEER / SCOP			Wh / Wh	7.00 / 4.30	7.10 / 4.30
Seasonal Energy Label		Cooling / Heating	-	A++ / A+	A++ / A+
Annual Energy Consumption		Cooling / Heating	kWh	400 / 1,758	394 / 1,823
Dehumidification Rate			ℓ/h	2.90	2.80
ODU Sound Pressure Level	Cooling	Rated	dB(A)	50	50
	Heating	Rated	dB(A)	52	52
ODU Sound Power Level	Cooling	Rated	dB(A)	68	68
	Heating	Rated	dB(A)	-	-
Piping Connections	Liquid	Outer Dia.	mm (inch)	Ø 9.52 (3/8)	Ø 9.52 (3/8)
	Gas	Outer Dia.	mm (inch)	Ø 15.88 (5/8)	Ø 15.88 (5/8)
Piping Length	Rated		m	7.5	7.5
	Min. / Max.		m	5.0 / 50.0	5.0 / 50.0
Refrigerant	Type		-	R32	R32
	GWP (Global Warming Potential)		-	675	675
	Precharged Amount		g	1,900	1,900
	t-CO ₂ eq.		-	1.283	1.283
	Control		-	EEV	EEV
	Chargeless-Pipe Length		m	20	20
	Additional Charging Volume		g/m	55	55

Note

- Due to our policy of innovation some specifications may be changed without notification.
- Wiring cable size must comply with the applicable local and national codes. And "Electric characteristics" chapter should be considered for electrical work and design. Especially the power cable and circuit breaker should be selected in accordance with that.
- Power factor could vary less than ±1% according to the operating conditions.
- Sound pressure level is measured on the rated condition in the anechoic rooms by ISO 3745 standard.
Sound power level is measured on the rated condition in the reverberation rooms by ISO 3741 standard.
Therefore, these values can be increased owing to ambient conditions during operation.
- Performances are based on the following conditions (It is accordance with EN14511) :
 - *Cooling : Indoor Ambient Temp. 27°CDB / 19°CWB, Outdoor Ambient Temp. 35°CDB / 24°CWB
 - *Heating : Indoor Ambient Temp. 20°CDB / 15°CWB, Outdoor Ambient Temp. 7°CDB / 6°CWB
 - Interconnected Pipe is standard length and difference of Elevation (Outdoor ~ Indoor Unit) is 0m.
- This product contains Fluorinated greenhouse gases.

2. Specifications

Combination	Outdoor unit			ZUUW30GA1 [UUC1 U40]	
	Indoor unit			ZBNW30GM1A2 [UM30F N11]	ZVNW30GM1A1 [UV30F N10]
Capacity	Cooling	Min.~Rated~Max.	kW	3.10 ~ 7.80 ~ 9.00	3.10 ~ 7.70 ~ 8.80
	Heating	Min.~Rated~Max.	kW	3.60 ~ 9.00 ~ 10.10	3.40 ~ 8.60 ~ 9.60
Power Input	Cooling	Min.~Rated~Max.	kW	0.40 ~ 2.23 ~ 3.03	0.50 ~ 2.25 ~ 3.08
	Heating	Min.~Rated~Max.	kW	0.50 ~ 2.64 ~ 3.33	0.50 ~ 2.50 ~ 3.20
Running Current	Cooling	Rated	A	9.90	10.00
	Heating	Rated	A	11.70	11.10
EER / COP			W / W	3.50 / 3.41	3.42 / 3.44
SEER / SCOP			Wh / Wh	6.10 / 4.00	6.80 / 4.40
Seasonal Energy Label		Cooling / Heating	-	A++ / A+	A++ / A+
Annual Energy Consumption		Cooling / Heating	kWh	448 / 1,890	396 / 1,718
Dehumidification Rate			ℓ/h	2.40	3.00
ODU Sound Pressure Level	Cooling	Rated	dB(A)	50	50
	Heating	Rated	dB(A)	52	52
ODU Sound Power Level	Cooling	Rated	dB(A)	68	68
	Heating	Rated	dB(A)	-	-
Piping Connections	Liquid	Outer Dia.	mm (inch)	Ø 9.52 (3/8)	Ø 9.52 (3/8)
	Gas	Outer Dia.	mm (inch)	Ø 15.88 (5/8)	Ø 15.88 (5/8)
Piping Length	Rated		m	7.5	7.5
	Min. / Max.		m	5.0 / 50.0	5.0 / 50.0
Refrigerant	Type		-	R32	R32
	GWP (Global Warming Potential)		-	675	675
	Precharged Amount		g	1,900	1,900
	t-CO ₂ eq.		-	1.283	1.283
	Control		-	EEV	EEV
	Chargeless-Pipe Length		m	20	20
	Additional Charging Volume		g/m	55	55

Note

- Due to our policy of innovation some specifications may be changed without notification.
- Wiring cable size must comply with the applicable local and national codes. And "Electric characteristics" chapter should be considered for electrical work and design. Especially the power cable and circuit breaker should be selected in accordance with that.
- Power factor could vary less than ±1% according to the operating conditions.
- Sound pressure level is measured on the rated condition in the anechoic rooms by ISO 3745 standard.
Sound power level is measured on the rated condition in the reverberation rooms by ISO 3741 standard.
Therefore, these values can be increased owing to ambient conditions during operation.
- Performances are based on the following conditions (It is accordance with EN14511) :
 - *Cooling : Indoor Ambient Temp. 27°CDB / 19°CWB, Outdoor Ambient Temp. 35°CDB / 24°CWB
 - *Heating : Indoor Ambient Temp. 20°CDB / 15°CWB, Outdoor Ambient Temp. 7°CDB / 6°CWB
 - Interconnected Pipe is standard length and difference of Elevation (Outdoor ~ Indoor Unit) is 0m.
- This product contains Fluorinated greenhouse gases.

2. Specifications

Combination	Outdoor unit			ZUUW30GA1 [UUC1 U40]
	Indoor unit			ZBNW30GMAA0 [UM30F NA0]
Capacity	Cooling	Min.~Rated~Max.	kW	3.10 ~ 7.50 ~ 9.00
	Heating	Min.~Rated~Max.	kW	3.60 ~ 9.00 ~ 10.00
Power Input	Cooling	Min.~Rated~Max.	kW	0.40 ~ 2.14 ~ 3.03
	Heating	Min.~Rated~Max.	kW	0.50 ~ 2.42 ~ 3.33
Running Current	Cooling	Rated	A	10.80
	Heating	Rated	A	13.70
EER / COP			W / W	3.50 / 3.71
SEER / SCOP			Wh / Wh	5.80 / 3.90
Seasonal Energy Label		Cooling / Heating	-	A+ / A
Annual Energy Consumption		Cooling / Heating	kWh	453 / 1,938
Dehumidification Rate			ℓ/h	2.59
ODU Sound Pressure Level	Cooling	Rated	dB(A)	50
	Heating	Rated	dB(A)	52
ODU Sound Power Level	Cooling	Rated	dB(A)	68
	Heating	Rated	dB(A)	-
Piping Connections	Liquid	Outer Dia.	mm (inch)	Ø 9.52 (3/8)
	Gas	Outer Dia.	mm (inch)	Ø 15.88 (5/8)
Piping Length	Rated		m	7.5
	Min. / Max.		m	5.0 / 50.0
Refrigerant	Type		-	R32
	GWP (Global Warming Potential)		-	675
	Precharged Amount		g	1,900
	t-CO ₂ eq.		-	1.283
	Control		-	EEV
	Chargeless-Pipe Length		m	20
	Additional Charging Volume		g/m	55

Note

- Due to our policy of innovation some specifications may be changed without notification.
- Wiring cable size must comply with the applicable local and national codes. And "Electric characteristics" chapter should be considered for electrical work and design. Especially the power cable and circuit breaker should be selected in accordance with that.
- Power factor could vary less than ±1% according to the operating conditions.
- Sound pressure level is measured on the rated condition in the anechoic rooms by ISO 3745 standard.
Sound power level is measured on the rated condition in the reverberation rooms by ISO 3741 standard.
Therefore, these values can be increased owing to ambient conditions during operation.
- Performances are based on the following conditions (It is accordance with EN14511) :
 - *Cooling : Indoor Ambient Temp. 27°CDB / 19°CWB, Outdoor Ambient Temp. 35°CDB / 24°CWB
 - *Heating : Indoor Ambient Temp. 20°CDB / 15°CWB, Outdoor Ambient Temp. 7°CDB / 6°CWB
 - Interconnected Pipe is standard length and difference of Elevation (Outdoor ~ Indoor Unit) is 0m.
- This product contains Fluorinated greenhouse gases.

2. Specifications

Combination	Outdoor unit			ZUUW48GA1 [UUD1 U30]	
	Indoor unit			ZJNW36GRLA1 [US36F NR0]	ZTNW36GALA1 [UT36F NAO]
Capacity	Cooling	Min.~Rated~Max.	kW	3.80 ~ 9.50 ~ 12.54	3.80 ~ 9.50 ~ 12.54
	Heating	Min.~Rated~Max.	kW	4.30 ~ 10.80 ~ 13.39	4.30 ~ 10.80 ~ 13.39
Power Input	Cooling	Min.~Rated~Max.	kW	0.30 ~ 2.57 ~ 3.91	0.50 ~ 2.26 ~ 3.44
	Heating	Min.~Rated~Max.	kW	0.50 ~ 2.77 ~ 3.77	0.50 ~ 2.43 ~ 3.30
Running Current	Cooling	Rated	A	11.40	10.10
	Heating	Rated	A	12.20	10.70
EER / COP			W / W	3.70 / 3.90	4.20 / 4.45
SEER / SCOP			Wh / Wh	6.10 / 3.85	7.00 / 4.30
Seasonal Energy Label		Cooling / Heating	-	A++ / A	A++ / A+
Annual Energy Consumption		Cooling / Heating	kWh	545 / 3,164	475 / 3,093
Dehumidification Rate			ℓ/h	3.83	2.38
ODU Sound Pressure Level	Cooling	Rated	dB(A)	50	50
	Heating	Rated	dB(A)	50	50
ODU Sound Power Level	Cooling	Rated	dB(A)	66	66
	Heating	Rated	dB(A)	-	-
Piping Connections	Liquid	Outer Dia.	mm (inch)	Ø 9.52 (3/8)	Ø 9.52 (3/8)
	Gas	Outer Dia.	mm (inch)	Ø 15.88 (5/8)	Ø 15.88 (5/8)
Piping Length	Rated		m	7.5	7.5
	Min. / Max.		m	5.0 / 85.0	5.0 / 85.0
Refrigerant	Type		-	R32	R32
	GWP (Global Warming Potential)		-	675	675
	Precharged Amount		g	3,000	3,000
	t-CO ₂ eq.		-	2.025	2.025
	Control		-	EEV	EEV
	Chargeless-Pipe Length		m	20	20
	Additional Charging Volume		g/m	50	50

Note

1. Due to our policy of innovation some specifications may be changed without notification.
2. Wiring cable size must comply with the applicable local and national codes. And "Electric characteristics" chapter should be considered for electrical work and design. Especially the power cable and circuit breaker should be selected in accordance with that.
3. Power factor could vary less than ±1% according to the operating conditions.
4. Sound pressure level is measured on the rated condition in the anechoic rooms by ISO 3745 standard.
Sound power level is measured on the rated condition in the reverberation rooms by ISO 3741 standard.
Therefore, these values can be increased owing to ambient conditions during operation.
5. Performances are based on the following conditions (It is accordance with EN14511) :
 - *Cooling : Indoor Ambient Temp. 27°CDB / 19°CWB, Outdoor Ambient Temp. 35°CDB / 24°CWB
 - *Heating : Indoor Ambient Temp. 20°CDB / 15°CWB, Outdoor Ambient Temp. 7°CDB / 6°CWB
 - Interconnected Pipe is standard length and difference of Elevation (Outdoor ~ Indoor Unit) is 0m.
6. This product contains Fluorinated greenhouse gases.

2. Specifications

Combination	Outdoor unit			ZUUW48GA1 [UUD1 U30]	
	Indoor unit			ZBNW36GM2A2 [UM36F N21]	ZVNW36GM2A1 [UV36F N20]
Capacity	Cooling	Min.~Rated~Max.	kW	3.80 ~ 9.50 ~ 12.54	3.80 ~ 9.50 ~ 12.54
	Heating	Min.~Rated~Max.	kW	4.30 ~ 10.80 ~ 13.39	4.30 ~ 10.80 ~ 13.39
Power Input	Cooling	Min.~Rated~Max.	kW	0.50 ~ 2.50 ~ 3.80	0.50 ~ 2.65 ~ 4.03
	Heating	Min.~Rated~Max.	kW	0.60 ~ 2.77 ~ 3.77	0.50 ~ 2.60 ~ 3.54
Running Current	Cooling	Rated	A	11.10	11.70
	Heating	Rated	A	12.60	11.40
EER / COP			W / W	3.80 / 3.90	3.59 / 4.15
SEER / SCOP			Wh / Wh	5.80 / 3.90	6.30 / 4.10
Seasonal Energy Label		Cooling / Heating	-	A+ / A	A++ / A+
Annual Energy Consumption		Cooling / Heating	kWh	573 / 3,410	528 / 3,244
Dehumidification Rate			ℓ/h	2.88	3.60
ODU Sound Pressure Level	Cooling	Rated	dB(A)	50	50
	Heating	Rated	dB(A)	50	50
ODU Sound Power Level	Cooling	Rated	dB(A)	66	66
	Heating	Rated	dB(A)	-	-
Piping Connections	Liquid	Outer Dia.	mm (inch)	Ø 9.52 (3/8)	Ø 9.52 (3/8)
	Gas	Outer Dia.	mm (inch)	Ø 15.88 (5/8)	Ø 15.88 (5/8)
Piping Length	Rated		m	7.5	7.5
	Min. / Max.		m	5.0 / 85.0	5.0 / 85.0
Refrigerant	Type		-	R32	R32
	GWP (Global Warming Potential)		-	675	675
	Precharged Amount		g	3,000	3,000
	t-CO ₂ eq.		-	2.025	2.025
	Control		-	EEV	EEV
	Chargeless-Pipe Length		m	20	20
	Additional Charging Volume		g/m	50	50

Note

- Due to our policy of innovation some specifications may be changed without notification.
- Wiring cable size must comply with the applicable local and national codes. And "Electric characteristics" chapter should be considered for electrical work and design. Especially the power cable and circuit breaker should be selected in accordance with that.
- Power factor could vary less than ±1% according to the operating conditions.
- Sound pressure level is measured on the rated condition in the anechoic rooms by ISO 3745 standard.
Sound power level is measured on the rated condition in the reverberation rooms by ISO 3741 standard.
Therefore, these values can be increased owing to ambient conditions during operation.
- Performances are based on the following conditions (It is accordance with EN14511) :
 - *Cooling : Indoor Ambient Temp. 27°CDB / 19°CWB, Outdoor Ambient Temp. 35°CDB / 24°CWB
 - *Heating : Indoor Ambient Temp. 20°CDB / 15°CWB, Outdoor Ambient Temp. 7°CDB / 6°CWB
 - Interconnected Pipe is standard length and difference of Elevation (Outdoor ~ Indoor Unit) is 0m.
- This product contains Fluorinated greenhouse gases.

2. Specifications

Combination	Outdoor unit			ZUUW48GA1 [UUD1 U30]
	Indoor unit			ZTNW36GYLA0 [UT36F NY0]
Capacity	Cooling	Min.~Rated~Max.	kW	3.80 ~ 11.00 ~ 12.54
	Heating	Min.~Rated~Max.	kW	4.30 ~ 12.20 ~ 13.39
Power Input	Cooling	Min.~Rated~Max.	kW	0.50 ~ 3.06 ~ 3.98
	Heating	Min.~Rated~Max.	kW	0.50 ~ 3.13 ~ 4.26
Running Current	Cooling	Rated	A	10.10
	Heating	Rated	A	10.70
EER / COP			W / W	3.60 / 3.90
SEER / SCOP			Wh / Wh	6.80 / 4.30
Seasonal Energy Label		Cooling / Heating	-	- / -
Annual Energy Consumption		Cooling / Heating	kWh	566 / 2,930
Dehumidification Rate			ℓ/h	4.27
ODU Sound Pressure Level	Cooling	Rated	dB(A)	50
	Heating	Rated	dB(A)	50
ODU Sound Power Level	Cooling	Rated	dB(A)	66
	Heating	Rated	dB(A)	-
Piping Connections	Liquid	Outer Dia.	mm (inch)	Ø 9.52 (3/8)
	Gas	Outer Dia.	mm (inch)	Ø 15.88 (5/8)
Piping Length	Rated		m	7.5
	Min. / Max.		m	5.0 / 85.0
Refrigerant	Type		-	R32
	GWP (Global Warming Potential)		-	675
	Precharged Amount		g	3,000
	t-CO ₂ eq.		-	2.025
	Control		-	EEV
	Chargeless-Pipe Length		m	20
	Additional Charging Volume		g/m	50

Note

- Due to our policy of innovation some specifications may be changed without notification.
- Wiring cable size must comply with the applicable local and national codes. And "Electric characteristics" chapter should be considered for electrical work and design. Especially the power cable and circuit breaker should be selected in accordance with that.
- Power factor could vary less than ±1% according to the operating conditions.
- Sound pressure level is measured on the rated condition in the anechoic rooms by ISO 3745 standard.
Sound power level is measured on the rated condition in the reverberation rooms by ISO 3741 standard.
Therefore, these values can be increased owing to ambient conditions during operation.
- Performances are based on the following conditions (It is accordance with EN14511) :
 - *Cooling : Indoor Ambient Temp. 27°CDB / 19°CWB, Outdoor Ambient Temp. 35°CDB / 24°CWB
 - *Heating : Indoor Ambient Temp. 20°CDB / 15°CWB, Outdoor Ambient Temp. 7°CDB / 6°CWB
 - Interconnected Pipe is standard length and difference of Elevation (Outdoor ~ Indoor Unit) is 0m.
- This product contains Fluorinated greenhouse gases.

2. Specifications

Combination	Outdoor unit			ZUUW48GA1 [UUD1 U30]	
	Indoor unit			ZTNW42GALA1 [UT42F NA0]	ZBNW42GM2A2 [UM42F N21]
Capacity	Cooling	Min.~Rated~Max.	kW	4.80 ~ 12.10 ~ 14.16	4.80 ~ 12.00 ~ 14.04
	Heating	Min.~Rated~Max.	kW	5.40 ~ 13.50 ~ 15.80	5.40 ~ 13.50 ~ 15.80
Power Input	Cooling	Min.~Rated~Max.	kW	0.70 ~ 3.31 ~ 4.30	0.70 ~ 3.48 ~ 4.52
	Heating	Min.~Rated~Max.	kW	0.70 ~ 3.51 ~ 4.56	0.80 ~ 3.74 ~ 4.86
Running Current	Cooling	Rated	A	14.60	15.30
	Heating	Rated	A	15.00	16.40
EER / COP			W / W	3.66 / 3.85	3.45 / 3.61
SEER / SCOP			Wh / Wh	7.00 / 4.30	5.60 / 3.90
Seasonal Space Energy Efficiency($\eta_{s,c} / \eta_{s,h}$)			% / %	277.0 / 169.0	- / -
Seasonal Energy Label		Cooling / Heating	-	- / -	A+ / A
Annual Energy Consumption		Cooling / Heating	kWh	1,037 / 3,093	750 / 3,410
Dehumidification Rate			l/h	4.49	4.44
ODU Sound Pressure Level	Cooling	Rated	dB(A)	51	51
	Heating	Rated	dB(A)	52	52
ODU Sound Power Level	Cooling	Rated	dB(A)	69	69
	Heating	Rated	dB(A)	69	-
Piping Connections	Liquid	Outer Dia.	mm (inch)	Ø 9.52 (3/8)	Ø 9.52 (3/8)
	Gas	Outer Dia.	mm (inch)	Ø 15.88 (5/8)	Ø 15.88 (5/8)
Piping Length	Rated		m	7.5	7.5
	Min. / Max.		m	5.0 / 85.0	5.0 / 85.0
Refrigerant	Type		-	R32	R32
	GWP (Global Warming Potential)		-	675	675
	Precharged Amount		g	3,000	3,000
	t-CO ₂ eq.		-	2.025	2.025
	Control		-	EEV	EEV
	Chargeless-Pipe Length		m	20	20
	Additional Charging Volume		g/m	50	50

Note

- Due to our policy of innovation some specifications may be changed without notification.
- Wiring cable size must comply with the applicable local and national codes. And "Electric characteristics" chapter should be considered for electrical work and design. Especially the power cable and circuit breaker should be selected in accordance with that.
- Power factor could vary less than ±1% according to the operating conditions.
- Sound pressure level is measured on the rated condition in the anechoic rooms by ISO 3745 standard.
Sound power level is measured on the rated condition in the reverberation rooms by ISO 3741 standard.
Therefore, these values can be increased owing to ambient conditions during operation.
- Performances are based on the following conditions (It is accordance with EN14511) :
 - *Cooling : Indoor Ambient Temp. 27°CDB / 19°CWB, Outdoor Ambient Temp. 35°CDB / 24°CWB
 - *Heating : Indoor Ambient Temp. 20°CDB / 15°CWB, Outdoor Ambient Temp. 7°CDB / 6°CWB
 - Interconnected Pipe is standard length and difference of Elevation (Outdoor ~ Indoor Unit) is 0m.
- This product contains Fluorinated greenhouse gases.

2. Specifications

Combination	Outdoor unit			ZUUW48GA1 [UUD1 U30]
	Indoor unit			ZVNW42GM2A1 [UV42F N20]
Capacity	Cooling	Min.~Rated~Max.	kW	4.80 ~ 12.10 ~ 14.16
	Heating	Min.~Rated~Max.	kW	5.40 ~ 13.50 ~ 15.80
Power Input	Cooling	Min.~Rated~Max.	kW	0.80 ~ 3.90 ~ 5.07
	Heating	Min.~Rated~Max.	kW	0.80 ~ 3.75 ~ 4.88
Running Current	Cooling	Rated	A	17.00
	Heating	Rated	A	16.50
EER / COP			W / W	3.10 / 3.60
SEER / SCOP			Wh / Wh	6.30 / 4.10
Seasonal Space Energy Efficiency($\eta_{s,c} / \eta_{s,h}$)			% / %	249.0 / 161.0
Seasonal Energy Label		Cooling / Heating	-	- / -
Annual Energy Consumption		Cooling / Heating	kWh	1,152 / 3,244
Dehumidification Rate			ℓ/h	5.52
ODU Sound Pressure Level	Cooling	Rated	dB(A)	51
	Heating	Rated	dB(A)	52
ODU Sound Power Level	Cooling	Rated	dB(A)	69
	Heating	Rated	dB(A)	69
Piping Connections	Liquid	Outer Dia.	mm (inch)	Ø 9.52 (3/8)
	Gas	Outer Dia.	mm (inch)	Ø 15.88 (5/8)
Piping Length	Rated		m	7.5
	Min. / Max.		m	5.0 / 85.0
Refrigerant	Type		-	R32
	GWP (Global Warming Potential)		-	675
	Precharged Amount		g	3,000
	t-CO ₂ eq.		-	2.025
	Control		-	EEV
	Chargeless-Pipe Length		m	20
	Additional Charging Volume		g/m	50

Note

- Due to our policy of innovation some specifications may be changed without notification.
- Wiring cable size must comply with the applicable local and national codes. And "Electric characteristics" chapter should be considered for electrical work and design. Especially the power cable and circuit breaker should be selected in accordance with that.
- Power factor could vary less than ±1% according to the operating conditions.
- Sound pressure level is measured on the rated condition in the anechoic rooms by ISO 3745 standard.
Sound power level is measured on the rated condition in the reverberation rooms by ISO 3741 standard.
Therefore, these values can be increased owing to ambient conditions during operation.
- Performances are based on the following conditions (It is accordance with EN14511) :
 - *Cooling : Indoor Ambient Temp. 27°CDB / 19°CWB, Outdoor Ambient Temp. 35°CDB / 24°CWB
 - *Heating : Indoor Ambient Temp. 20°CDB / 15°CWB, Outdoor Ambient Temp. 7°CDB / 6°CWB
 - Interconnected Pipe is standard length and difference of Elevation (Outdoor ~ Indoor Unit) is 0m.
- This product contains Fluorinated greenhouse gases.

2. Specifications

Combination	Outdoor unit			ZUUW48GA1 [UUD1 U30]	
	Indoor unit			ZTNW48GALA1 [UT48F NA0]	ZBNW48GM3A2 [UM48F N31]
Capacity	Cooling	Min.~Rated~Max.	kW	5.40 ~ 13.40 ~ 15.68	5.40 ~ 13.40 ~ 15.68
	Heating	Min.~Rated~Max.	kW	6.20 ~ 15.50 ~ 17.52	6.20 ~ 15.50 ~ 17.52
Power Input	Cooling	Min.~Rated~Max.	kW	0.90 ~ 4.25 ~ 5.53	0.90 ~ 4.32 ~ 5.62
	Heating	Min.~Rated~Max.	kW	0.90 ~ 4.37 ~ 5.33	0.90 ~ 4.31 ~ 5.26
Running Current	Cooling	Rated	A	18.70	19.00
	Heating	Rated	A	19.00	18.40
EER / COP			W / W	3.15 / 3.55	3.10 / 3.60
SEER / SCOP			Wh / Wh	6.50 / 4.20	5.80 / 4.00
Seasonal Space Energy Efficiency($\eta_{s,c} / \eta_{s,h}$)			% / %	257.0 / 165.0	229.0 / 157.0
Seasonal Energy Label		Cooling / Heating	-	- / -	- / -
Annual Energy Consumption		Cooling / Heating	kWh	1,237 / 3,167	1,386 / 3,325
Dehumidification Rate			l/h	5.73	4.81
ODU Sound Pressure Level	Cooling	Rated	dB(A)	52	52
	Heating	Rated	dB(A)	53	53
ODU Sound Power Level	Cooling	Rated	dB(A)	69	69
	Heating	Rated	dB(A)	69	69
Piping Connections	Liquid	Outer Dia.	mm (inch)	Ø 9.52 (3/8)	Ø 9.52 (3/8)
	Gas	Outer Dia.	mm (inch)	Ø 15.88 (5/8)	Ø 15.88 (5/8)
Piping Length	Rated		m	7.5	7.5
	Min. / Max.		m	5.0 / 85.0	5.0 / 85.0
Refrigerant	Type		-	R32	R32
	GWP (Global Warming Potential)		-	675	675
	Precharged Amount		g	3,000	3,000
	t-CO ₂ eq.		-	2.025	2.025
	Control		-	EEV	EEV
	Chargeless-Pipe Length		m	20	20
	Additional Charging Volume		g/m	50	50

Note

- Due to our policy of innovation some specifications may be changed without notification.
- Wiring cable size must comply with the applicable local and national codes. And "Electric characteristics" chapter should be considered for electrical work and design. Especially the power cable and circuit breaker should be selected in accordance with that.
- Power factor could vary less than $\pm 1\%$ according to the operating conditions.
- Sound pressure level is measured on the rated condition in the anechoic rooms by ISO 3745 standard.
Sound power level is measured on the rated condition in the reverberation rooms by ISO 3741 standard.
Therefore, these values can be increased owing to ambient conditions during operation.
- Performances are based on the following conditions (It is accordance with EN14511) :
 - *Cooling : Indoor Ambient Temp. 27°CDB / 19°CWB, Outdoor Ambient Temp. 35°CDB / 24°CWB
 - *Heating : Indoor Ambient Temp. 20°CDB / 15°CWB, Outdoor Ambient Temp. 7°CDB / 6°CWB
 - Interconnected Pipe is standard length and difference of Elevation (Outdoor ~ Indoor Unit) is 0m.
- This product contains Fluorinated greenhouse gases.

2. Specifications

Combination	Outdoor unit			ZUUW48GA1 [UUD1 U30]	
	Indoor unit			ZVNW48GM2A1 [UV48F N20]	ZTNW48GYLA0 [UT48F NY0]
Capacity	Cooling	Min.~Rated~Max.	kW	5.40 ~ 13.40 ~ 15.68	5.40 ~ 13.40 ~ 15.68
	Heating	Min.~Rated~Max.	kW	6.20 ~ 15.50 ~ 17.52	6.20 ~ 15.50 ~ 17.52
Power Input	Cooling	Min.~Rated~Max.	kW	0.90 ~ 4.50 ~ 5.85	0.90 ~ 4.39 ~ 5.71
	Heating	Min.~Rated~Max.	kW	0.90 ~ 4.77 ~ 5.82	0.90 ~ 4.56 ~ 5.56
Running Current	Cooling	Rated	A	19.70	19.50
	Heating	Rated	A	20.60	20.20
EER / COP			W / W	2.98 / 3.25	3.05 / 3.40
SEER / SCOP			Wh / Wh	5.90 / 4.10	6.50 / 4.30
Seasonal Space Energy Efficiency($\eta_{s,c} / \eta_{s,h}$)			% / %	233.0 / 161.0	257.0 / 169.0
Seasonal Energy Label		Cooling / Heating	-	- / -	- / -
Annual Energy Consumption		Cooling / Heating	kWh	1,363 / 3,244	1,237 / 2,930
Dehumidification Rate			ℓ/h	6.28	5.65
ODU Sound Pressure Level	Cooling	Rated	dB(A)	52	52
	Heating	Rated	dB(A)	53	53
ODU Sound Power Level	Cooling	Rated	dB(A)	69	69
	Heating	Rated	dB(A)	69	69
Piping Connections	Liquid	Outer Dia.	mm (inch)	Ø 9.52 (3/8)	Ø 9.52 (3/8)
	Gas	Outer Dia.	mm (inch)	Ø 15.88 (5/8)	Ø 15.88 (5/8)
Piping Length	Rated		m	7.5	7.5
	Min. / Max.		m	5.0 / 85.0	5.0 / 85.0
Refrigerant	Type		-	R32	R32
	GWP (Global Warming Potential)		-	675	675
	Precharged Amount		g	3,000	3,000
	t-CO ₂ eq.		-	2.025	2.025
	Control		-	EEV	EEV
	Chargeless-Pipe Length		m	20	20
	Additional Charging Volume		g/m	50	50

Note

- Due to our policy of innovation some specifications may be changed without notification.
- Wiring cable size must comply with the applicable local and national codes. And "Electric characteristics" chapter should be considered for electrical work and design. Especially the power cable and circuit breaker should be selected in accordance with that.
- Power factor could vary less than $\pm 1\%$ according to the operating conditions.
- Sound pressure level is measured on the rated condition in the anechoic rooms by ISO 3745 standard.
Sound power level is measured on the rated condition in the reverberation rooms by ISO 3741 standard.
Therefore, these values can be increased owing to ambient conditions during operation.
- Performances are based on the following conditions (It is accordance with EN14511) :
 - *Cooling : Indoor Ambient Temp. 27°CDB / 19°CWB, Outdoor Ambient Temp. 35°CDB / 24°CWB
 - *Heating : Indoor Ambient Temp. 20°CDB / 15°CWB, Outdoor Ambient Temp. 7°CDB / 6°CWB
 - Interconnected Pipe is standard length and difference of Elevation (Outdoor ~ Indoor Unit) is 0m.
- This product contains Fluorinated greenhouse gases.

2. Specifications

Combination	Outdoor unit			ZUUW48GA1 [UUD1 U30]	
	Indoor unit			ZTNW60GALA1 [UT60F NA0]	ZBNW60GM3A2 [UM60F N31]
Capacity	Cooling	Min.~Rated~Max.	kW	5.80 ~ 14.60~ 15.77	5.80 ~ 14.60 ~ 15.77
	Heating	Min.~Rated~Max.	kW	6.80 ~ 16.90 ~ 18.25	6.70 ~ 16.80 ~ 18.14
Power Input	Cooling	Min.~Rated~Max.	kW	1.00 ~ 5.21 ~ 5.84	1.00 ~ 4.95 ~ 5.54
	Heating	Min.~Rated~Max.	kW	1.00 ~ 5.12 ~ 5.89	0.90 ~ 4.60 ~ 5.29
Running Current	Cooling	Rated	A	23.10	21.60
	Heating	Rated	A	22.70	20.40
EER / COP			W / W	2.80 / 3.30	2.95 / 3.65
SEER / SCOP			Wh / Wh	6.20 / 4.20	5.60 / 4.00
Seasonal Space Energy Efficiency($\eta_{s,c} / \eta_{s,h}$)			% / %	245.0 / 165.0	221.0 / 157.0
Seasonal Energy Label		Cooling / Heating	-	- / -	- / -
Annual Energy Consumption		Cooling / Heating	kWh	1,413 / 3,167	1,564 / 3,325
Dehumidification Rate			ℓ/h	6.58	4.68
ODU Sound Pressure Level	Cooling	Rated	dB(A)	54	54
	Heating	Rated	dB(A)	54	54
ODU Sound Power Level	Cooling	Rated	dB(A)	71	71
	Heating	Rated	dB(A)	71	71
Piping Connections	Liquid	Outer Dia.	mm (inch)	Ø 9.52 (3/8)	Ø 9.52 (3/8)
	Gas	Outer Dia.	mm (inch)	Ø 15.88 (5/8)	Ø 15.88 (5/8)
Piping Length	Rated		m	7.5	7.5
	Min. / Max.		m	5.0 / 85.0	5.0 / 85.0
Refrigerant	Type		-	R32	R32
	GWP (Global Warming Potential)		-	675	675
	Precharged Amount		g	3,000	3,000
	t-CO ₂ eq.		-	2.025	2.025
	Control		-	EEV	EEV
	Chargeless-Pipe Length		m	20	20
	Additional Charging Volume		g/m	50	50

Note

- Due to our policy of innovation some specifications may be changed without notification.
- Wiring cable size must comply with the applicable local and national codes. And "Electric characteristics" chapter should be considered for electrical work and design. Especially the power cable and circuit breaker should be selected in accordance with that.
- Power factor could vary less than $\pm 1\%$ according to the operating conditions.
- Sound pressure level is measured on the rated condition in the anechoic rooms by ISO 3745 standard.
Sound power level is measured on the rated condition in the reverberation rooms by ISO 3741 standard.
Therefore, these values can be increased owing to ambient conditions during operation.
- Performances are based on the following conditions (It is accordance with EN14511) :
 - *Cooling : Indoor Ambient Temp. 27°CDB / 19°CWB, Outdoor Ambient Temp. 35°CDB / 24°CWB
 - *Heating : Indoor Ambient Temp. 20°CDB / 15°CWB, Outdoor Ambient Temp. 7°CDB / 6°CWB
 - Interconnected Pipe is standard length and difference of Elevation (Outdoor ~ Indoor Unit) is 0m.
- This product contains Fluorinated greenhouse gases.

2. Specifications

Combination	Outdoor unit			ZUUW48GA1 [UUD1 U30]
	Indoor unit			ZVNW60GM2A1 [UV60F N20]
Capacity	Cooling	Min.~Rated~Max.	kW	5.80 ~ 14.40 ~ 15.55
	Heating	Min.~Rated~Max.	kW	6.70 ~ 16.80 ~ 18.14
Power Input	Cooling	Min.~Rated~Max.	kW	1.10 ~ 5.33 ~ 5.97
	Heating	Min.~Rated~Max.	kW	1.10 ~ 5.60 ~ 6.44
Running Current	Cooling	Rated	A	23.60
	Heating	Rated	A	24.60
EER / COP			W / W	2.70 / 3.00
SEER / SCOP			Wh / Wh	5.70 / 4.10
Seasonal Space Energy Efficiency($\eta_{s,c} / \eta_{s,h}$)			% / %	225.0 / 161.0
Seasonal Energy Label		Cooling / Heating	-	- / -
Annual Energy Consumption		Cooling / Heating	kWh	1,516 / 3,244
Dehumidification Rate			ℓ/h	7.13
ODU Sound Pressure Level	Cooling	Rated	dB(A)	54
	Heating	Rated	dB(A)	54
ODU Sound Power Level	Cooling	Rated	dB(A)	71
	Heating	Rated	dB(A)	71
Piping Connections	Liquid	Outer Dia.	mm (inch)	Ø 9.52 (3/8)
	Gas	Outer Dia.	mm (inch)	Ø 15.88 (5/8)
Piping Length		Rated	m	7.5
		Min. / Max.	m	5.0 / 85.0
Refrigerant	Type		-	R32
	GWP (Global Warming Potential)		-	675
	Precharged Amount		g	3,000
	t-CO ₂ eq.		-	2.025
	Control		-	EEV
	Chargeless-Pipe Length		m	20
	Additional Charging Volume		g/m	50

Note

- Due to our policy of innovation some specifications may be changed without notification.
- Wiring cable size must comply with the applicable local and national codes. And "Electric characteristics" chapter should be considered for electrical work and design. Especially the power cable and circuit breaker should be selected in accordance with that.
- Power factor could vary less than $\pm 1\%$ according to the operating conditions.
- Sound pressure level is measured on the rated condition in the anechoic rooms by ISO 3745 standard.
Sound power level is measured on the rated condition in the reverberation rooms by ISO 3741 standard.
Therefore, these values can be increased owing to ambient conditions during operation.
- Performances are based on the following conditions (It is accordance with EN14511) :
 - *Cooling : Indoor Ambient Temp. 27°CDB / 19°CWB, Outdoor Ambient Temp. 35°CDB / 24°CWB
 - *Heating : Indoor Ambient Temp. 20°CDB / 15°CWB, Outdoor Ambient Temp. 7°CDB / 6°CWB
 - Interconnected Pipe is standard length and difference of Elevation (Outdoor ~ Indoor Unit) is 0m.
- This product contains Fluorinated greenhouse gases.

2. Specifications

◆ Standard(3 Phase Inverter)

Combination	Outdoor unit			ZUUW48LA1 [UUD3 U30]	
	Indoor unit			ZJNW36GRLA1 [US36F NR0]	ZTNW36GALA1 [UT36F NA0]
Capacity	Cooling	Min.~Rated~Max.	kW	3.80 ~ 9.50 ~ 12.54	3.80 ~ 9.50 ~ 12.54
	Heating	Min.~Rated~Max.	kW	4.30 ~ 10.80 ~ 13.39	4.30 ~ 10.80 ~ 13.39
Power Input	Cooling	Min.~Rated~Max.	kW	0.30 ~ 2.57 ~ 3.91	0.50 ~ 2.26 ~ 3.44
	Heating	Min.~Rated~Max.	kW	0.50 ~ 2.77 ~ 3.77	0.50 ~ 2.43 ~ 3.30
Running Current	Cooling	Rated	A	4.10	3.80
	Heating	Rated	A	4.40	3.90
EER / COP			W / W	3.70 / 3.90	4.20 / 4.45
SEER / SCOP			Wh / Wh	6.10 / 3.85	7.00 / 4.30
Seasonal Energy Label		Cooling / Heating	-	A++ / A	A++ / A+
Annual Energy Consumption		Cooling / Heating	kWh	545 / 3,164	475 / 3,093
Dehumidification Rate			ℓ/h	3.83	2.38
ODU Sound Pressure Level	Cooling	Rated	dB(A)	50	50
	Heating	Rated	dB(A)	50	50
ODU Sound Power Level	Cooling	Rated	dB(A)	66	66
	Heating	Rated	dB(A)	-	-
Piping Connections	Liquid	Outer Dia.	mm (inch)	Ø 9.52 (3/8)	Ø 9.52 (3/8)
	Gas	Outer Dia.	mm (inch)	Ø 15.88 (5/8)	Ø 15.88 (5/8)
Piping Length	Rated		m	7.5	7.5
	Min. / Max.		m	5.0 / 85.0	5.0 / 85.0
Refrigerant	Type		-	R32	R32
	GWP (Global Warming Potential)		-	675	675
	Precharged Amount		g	3,000	3,000
	t-CO ₂ eq.		-	2.025	2.025
	Control		-	EEV	EEV
	Chargeless-Pipe Length		m	20	20
	Additional Charging Volume		g/m	50	50

Note

- Due to our policy of innovation some specifications may be changed without notification.
- Wiring cable size must comply with the applicable local and national codes. And "Electric characteristics" chapter should be considered for electrical work and design. Especially the power cable and circuit breaker should be selected in accordance with that.
- Power factor could vary less than ±1% according to the operating conditions.
- Sound pressure level is measured on the rated condition in the anechoic rooms by ISO 3745 standard.
Sound power level is measured on the rated condition in the reverberation rooms by ISO 3741 standard.
Therefore, these values can be increased owing to ambient conditions during operation.
- Performances are based on the following conditions (It is accordance with EN14511) :
 - *Cooling : Indoor Ambient Temp. 27°CDB / 19°CWB, Outdoor Ambient Temp. 35°CDB / 24°CWB
 - *Heating : Indoor Ambient Temp. 20°CDB / 15°CWB, Outdoor Ambient Temp. 7°CDB / 6°CWB
 - Interconnected Pipe is standard length and difference of Elevation (Outdoor ~ Indoor Unit) is 0m.
- This product contains Fluorinated greenhouse gases.

2. Specifications

Combination	Outdoor unit			ZUUW48LA1 [UUD3 U30]	
	Indoor unit			ZBNW36GM2A2 [UM36F N21]	ZVNW36GM2A1 [UV36F N20]
Capacity	Cooling	Min.~Rated~Max.	kW	3.80 ~ 9.50 ~ 12.54	3.80 ~ 9.50 ~ 12.54
	Heating	Min.~Rated~Max.	kW	4.30 ~ 10.80 ~ 13.39	4.30 ~ 10.80 ~ 13.39
Power Input	Cooling	Min.~Rated~Max.	kW	0.50 ~ 2.50 ~ 3.80	0.50 ~ 2.65 ~ 4.03
	Heating	Min.~Rated~Max.	kW	0.60 ~ 2.77 ~ 3.77	0.50 ~ 2.60 ~ 3.54
Running Current	Cooling	Rated	A	4.00	4.20
	Heating	Rated	A	4.50	4.10
EER / COP			W / W	3.80 / 3.90	3.59 / 4.15
SEER / SCOP			Wh / Wh	5.80 / 3.90	6.30 / 4.10
Seasonal Energy Label		Cooling / Heating	-	A+ / A	A++ / A+
Annual Energy Consumption		Cooling / Heating	kWh	573 / 3,410	528 / 3,244
Dehumidification Rate			ℓ/h	2.88	3.60
ODU Sound Pressure Level	Cooling	Rated	dB(A)	50	50
	Heating	Rated	dB(A)	50	50
ODU Sound Power Level	Cooling	Rated	dB(A)	66	66
	Heating	Rated	dB(A)	-	-
Piping Connections	Liquid	Outer Dia.	mm (inch)	Ø 9.52 (3/8)	Ø 9.52 (3/8)
	Gas	Outer Dia.	mm (inch)	Ø 15.88 (5/8)	Ø 15.88 (5/8)
Piping Length	Rated		m	7.5	7.5
	Min. / Max.		m	5.0 / 85.0	5.0 / 85.0
Refrigerant	Type		-	R32	R32
	GWP (Global Warming Potential)		-	675	675
	Precharged Amount		g	3,000	3,000
	t-CO ₂ eq.		-	2.025	2.025
	Control		-	EEV	EEV
	Chargeless-Pipe Length		m	20	20
	Additional Charging Volume		g/m	50	50

Note

- Due to our policy of innovation some specifications may be changed without notification.
- Wiring cable size must comply with the applicable local and national codes. And "Electric characteristics" chapter should be considered for electrical work and design. Especially the power cable and circuit breaker should be selected in accordance with that.
- Power factor could vary less than ±1% according to the operating conditions.
- Sound pressure level is measured on the rated condition in the anechoic rooms by ISO 3745 standard.
Sound power level is measured on the rated condition in the reverberation rooms by ISO 3741 standard.
Therefore, these values can be increased owing to ambient conditions during operation.
- Performances are based on the following conditions (It is accordance with EN14511) :
 - *Cooling : Indoor Ambient Temp. 27°CDB / 19°CWB, Outdoor Ambient Temp. 35°CDB / 24°CWB
 - *Heating : Indoor Ambient Temp. 20°CDB / 15°CWB, Outdoor Ambient Temp. 7°CDB / 6°CWB
 - Interconnected Pipe is standard length and difference of Elevation (Outdoor ~ Indoor Unit) is 0m.
- This product contains Fluorinated greenhouse gases.

2. Specifications

Combination	Outdoor unit			ZUUW48LA1 [UUD3 U30]
	Indoor unit			ZTNW36GYLA0 [UT36F NY0]
Capacity	Cooling	Min.~Rated~Max.	kW	3.80 ~ 11.00 ~ 12.54
	Heating	Min.~Rated~Max.	kW	4.30 ~ 12.20 ~ 13.39
Power Input	Cooling	Min.~Rated~Max.	kW	0.50 ~ 3.06 ~ 3.98
	Heating	Min.~Rated~Max.	kW	0.50 ~ 3.13 ~ 4.26
Running Current	Cooling	Rated	A	5.20
	Heating	Rated	A	5.30
EER / COP			W / W	3.60 / 3.90
SEER / SCOP			Wh / Wh	6.80 / 4.30
Seasonal Energy Label		Cooling / Heating	-	- / -
Annual Energy Consumption		Cooling / Heating	kWh	566 / 2,931
Dehumidification Rate			ℓ/h	4.27
ODU Sound Pressure Level	Cooling	Rated	dB(A)	50
	Heating	Rated	dB(A)	50
ODU Sound Power Level	Cooling	Rated	dB(A)	66
	Heating	Rated	dB(A)	-
Piping Connections	Liquid	Outer Dia.	mm (inch)	Ø 9.52 (3/8)
	Gas	Outer Dia.	mm (inch)	Ø 15.88 (5/8)
Piping Length	Rated		m	7.5
	Min. / Max.		m	5.0 / 85.0
Refrigerant	Type		-	R32
	GWP (Global Warming Potential)		-	675
	Precharged Amount		g	3,000
	t-CO ₂ eq.		-	2.025
	Control		-	EEV
	Chargeless-Pipe Length		m	20
	Additional Charging Volume		g/m	50

Note

- Due to our policy of innovation some specifications may be changed without notification.
- Wiring cable size must comply with the applicable local and national codes. And "Electric characteristics" chapter should be considered for electrical work and design. Especially the power cable and circuit breaker should be selected in accordance with that.
- Power factor could vary less than ±1% according to the operating conditions.
- Sound pressure level is measured on the rated condition in the anechoic rooms by ISO 3745 standard.
Sound power level is measured on the rated condition in the reverberation rooms by ISO 3741 standard.
Therefore, these values can be increased owing to ambient conditions during operation.
- Performances are based on the following conditions (It is accordance with EN14511) :
 - *Cooling : Indoor Ambient Temp. 27°CDB / 19°CWB, Outdoor Ambient Temp. 35°CDB / 24°CWB
 - *Heating : Indoor Ambient Temp. 20°CDB / 15°CWB, Outdoor Ambient Temp. 7°CDB / 6°CWB
 - Interconnected Pipe is standard length and difference of Elevation (Outdoor ~ Indoor Unit) is 0m.
- This product contains Fluorinated greenhouse gases.

2. Specifications

Combination	Outdoor unit			ZUUW48LA1 [UUD3 U30]	
	Indoor unit			ZTNW42GALA1 [UT42F NA0]	ZBNW42GM2A2 [UM42F N21]
Capacity	Cooling	Min.~Rated~Max.	kW	4.80 ~ 12.10 ~ 14.16	4.80 ~ 12.00 ~ 14.04
	Heating	Min.~Rated~Max.	kW	5.40 ~ 13.50 ~ 15.80	5.40 ~ 13.50 ~ 15.80
Power Input	Cooling	Min.~Rated~Max.	kW	0.70 ~ 3.31 ~ 4.30	0.70 ~ 3.48 ~ 4.52
	Heating	Min.~Rated~Max.	kW	0.70 ~ 3.51 ~ 4.56	0.80 ~ 3.74 ~ 4.86
Running Current	Cooling	Rated	A	5.20	5.50
	Heating	Rated	A	5.40	5.90
EER / COP			W / W	3.66 / 3.85	3.45 / 3.61
SEER / SCOP			Wh / Wh	7.00 / 4.30	5.60 / 3.90
Seasonal Space Energy Efficiency($\eta_{s,c} / \eta_{s,h}$)			% / %	277.0 / 169.0	- / -
Seasonal Energy Label		Cooling / Heating	-	- / -	A+ / A
Annual Energy Consumption		Cooling / Heating	kWh	1,037 / 3,093	750 / 3,410
Dehumidification Rate			l/h	4.49	4.44
ODU Sound Pressure Level	Cooling	Rated	dB(A)	51	51
	Heating	Rated	dB(A)	52	52
ODU Sound Power Level	Cooling	Rated	dB(A)	69	69
	Heating	Rated	dB(A)	69	-
Piping Connections	Liquid	Outer Dia.	mm (inch)	Ø 9.52 (3/8)	Ø 9.52 (3/8)
	Gas	Outer Dia.	mm (inch)	Ø 15.88 (5/8)	Ø 15.88 (5/8)
Piping Length	Rated		m	7.5	7.5
	Min. / Max.		m	5.0 / 85.0	5.0 / 85.0
Refrigerant	Type		-	R32	R32
	GWP (Global Warming Potential)		-	675	675
	Precharged Amount		g	3,000	3,000
	t-CO ₂ eq.		-	2.025	2.025
	Control		-	EEV	EEV
	Chargeless-Pipe Length		m	20	20
	Additional Charging Volume		g/m	50	50

Note

- Due to our policy of innovation some specifications may be changed without notification.
- Wiring cable size must comply with the applicable local and national codes. And "Electric characteristics" chapter should be considered for electrical work and design. Especially the power cable and circuit breaker should be selected in accordance with that.
- Power factor could vary less than $\pm 1\%$ according to the operating conditions.
- Sound pressure level is measured on the rated condition in the anechoic rooms by ISO 3745 standard.
Sound power level is measured on the rated condition in the reverberation rooms by ISO 3741 standard.
Therefore, these values can be increased owing to ambient conditions during operation.
- Performances are based on the following conditions (It is accordance with EN14511) :
 - *Cooling : Indoor Ambient Temp. 27°CDB / 19°CWB, Outdoor Ambient Temp. 35°CDB / 24°CWB
 - *Heating : Indoor Ambient Temp. 20°CDB / 15°CWB, Outdoor Ambient Temp. 7°CDB / 6°CWB
 - Interconnected Pipe is standard length and difference of Elevation (Outdoor ~ Indoor Unit) is 0m.
- This product contains Fluorinated greenhouse gases.

2. Specifications

Combination	Outdoor unit			ZUUW48LA1 [UUD3 U30]
	Indoor unit			ZVNW42GM2A1 [UV42F N20]
Capacity	Cooling	Min.~Rated~Max.	kW	4.80 ~ 12.10 ~ 14.16
	Heating	Min.~Rated~Max.	kW	5.40 ~ 13.50 ~ 15.80
Power Input	Cooling	Min.~Rated~Max.	kW	0.80 ~ 3.90 ~ 5.07
	Heating	Min.~Rated~Max.	kW	0.80 ~ 3.75 ~ 4.88
Running Current	Cooling	Rated	A	6.10
	Heating	Rated	A	5.90
EER / COP			W / W	3.10 / 3.60
SEER / SCOP			Wh / Wh	6.30 / 4.10
Seasonal Space Energy Efficiency($\eta_{s,c} / \eta_{s,h}$)			% / %	249.0 / 161.0
Seasonal Energy Label		Cooling / Heating	-	- / -
Annual Energy Consumption		Cooling / Heating	kWh	1,152 / 3,244
Dehumidification Rate			ℓ/h	5.52
ODU Sound Pressure Level	Cooling	Rated	dB(A)	51
	Heating	Rated	dB(A)	52
ODU Sound Power Level	Cooling	Rated	dB(A)	69
	Heating	Rated	dB(A)	69
Piping Connections	Liquid	Outer Dia.	mm (inch)	Ø 9.52 (3/8)
	Gas	Outer Dia.	mm (inch)	Ø 15.88 (5/8)
Piping Length	Rated		m	7.5
	Min. / Max.		m	5.0 / 85.0
Refrigerant	Type		-	R32
	GWP (Global Warming Potential)		-	675
	Precharged Amount		g	3,000
	t-CO ₂ eq.		-	2.025
	Control		-	EEV
	Chargeless-Pipe Length		m	20
	Additional Charging Volume		g/m	50

Note

- Due to our policy of innovation some specifications may be changed without notification.
- Wiring cable size must comply with the applicable local and national codes. And "Electric characteristics" chapter should be considered for electrical work and design. Especially the power cable and circuit breaker should be selected in accordance with that.
- Power factor could vary less than $\pm 1\%$ according to the operating conditions.
- Sound pressure level is measured on the rated condition in the anechoic rooms by ISO 3745 standard.
Sound power level is measured on the rated condition in the reverberation rooms by ISO 3741 standard.
Therefore, these values can be increased owing to ambient conditions during operation.
- Performances are based on the following conditions (It is accordance with EN14511) :
 - *Cooling : Indoor Ambient Temp. 27°CDB / 19°CWB, Outdoor Ambient Temp. 35°CDB / 24°CWB
 - *Heating : Indoor Ambient Temp. 20°CDB / 15°CWB, Outdoor Ambient Temp. 7°CDB / 6°CWB
 - Interconnected Pipe is standard length and difference of Elevation (Outdoor ~ Indoor Unit) is 0m.
- This product contains Fluorinated greenhouse gases.

2. Specifications

Combination	Outdoor unit			ZUUW48LA1 [UUD3 U30]	
	Indoor unit			ZTNW48GALA1 [UT48F NA0]	ZBNW48GM3A2 [UM48F N31]
Capacity	Cooling	Min.~Rated~Max.	kW	5.40 ~ 13.40 ~ 15.68	5.40 ~ 13.40 ~ 15.68
	Heating	Min.~Rated~Max.	kW	6.20 ~ 15.50 ~ 17.52	6.20 ~ 15.50 ~ 17.52
Power Input	Cooling	Min.~Rated~Max.	kW	0.90 ~ 4.25 ~ 5.53	0.90 ~ 4.32 ~ 5.62
	Heating	Min.~Rated~Max.	kW	0.90 ~ 4.37 ~ 5.33	0.90 ~ 4.31 ~ 5.26
Running Current	Cooling	Rated	A	6.60	6.80
	Heating	Rated	A	6.70	6.50
EER / COP			W / W	3.15 / 3.55	3.10 / 3.60
SEER / SCOP			Wh / Wh	6.50 / 4.20	5.80 / 4.00
Seasonal Space Energy Efficiency($\eta_{s,c} / \eta_{s,h}$)			% / %	257.0 / 165.0	229.0 / 157.0
Seasonal Energy Label		Cooling / Heating	-	- / -	- / -
Annual Energy Consumption		Cooling / Heating	kWh	1,237 / 3,167	1,386 / 3,325
Dehumidification Rate			l/h	5.73	4.81
ODU Sound Pressure Level	Cooling	Rated	dB(A)	52	52
	Heating	Rated	dB(A)	53	53
ODU Sound Power Level	Cooling	Rated	dB(A)	69	69
	Heating	Rated	dB(A)	69	69
Piping Connections	Liquid	Outer Dia.	mm (inch)	Ø 9.52 (3/8)	Ø 9.52 (3/8)
	Gas	Outer Dia.	mm (inch)	Ø 15.88 (5/8)	Ø 15.88 (5/8)
Piping Length	Rated		m	7.5	7.5
	Min. / Max.		m	5.0 / 85.0	5.0 / 85.0
Refrigerant	Type		-	R32	R32
	GWP (Global Warming Potential)		-	675	675
	Precharged Amount		g	3,000	3,000
	t-CO ₂ eq.		-	2.025	2.025
	Control		-	EEV	EEV
	Chargeless-Pipe Length		m	20	20
	Additional Charging Volume		g/m	50	50

Note

- Due to our policy of innovation some specifications may be changed without notification.
- Wiring cable size must comply with the applicable local and national codes. And "Electric characteristics" chapter should be considered for electrical work and design. Especially the power cable and circuit breaker should be selected in accordance with that.
- Power factor could vary less than $\pm 1\%$ according to the operating conditions.
- Sound pressure level is measured on the rated condition in the anechoic rooms by ISO 3745 standard.
Sound power level is measured on the rated condition in the reverberation rooms by ISO 3741 standard.
Therefore, these values can be increased owing to ambient conditions during operation.
- Performances are based on the following conditions (It is accordance with EN14511) :
 - *Cooling : Indoor Ambient Temp. 27°CDB / 19°CWB, Outdoor Ambient Temp. 35°CDB / 24°CWB
 - *Heating : Indoor Ambient Temp. 20°CDB / 15°CWB, Outdoor Ambient Temp. 7°CDB / 6°CWB
 - Interconnected Pipe is standard length and difference of Elevation (Outdoor ~ Indoor Unit) is 0m.
- This product contains Fluorinated greenhouse gases.

2. Specifications

Combination	Outdoor unit			ZUUW48LA1 [UUD3 U30]	ZUUW48LA1 [UUD3 U30]
	Indoor unit			ZVNW48GM2A1 [UV48F N20]	ZTNW48GYLA0 [UT48F NY0]
Capacity	Cooling	Min.~Rated~Max.	kW	5.40 ~ 13.40 ~ 15.68	5.40 ~ 13.40 ~ 15.68
	Heating	Min.~Rated~Max.	kW	6.20 ~ 15.50 ~ 17.52	6.20 ~ 15.50 ~ 17.52
Power Input	Cooling	Min.~Rated~Max.	kW	0.90 ~ 4.50 ~ 5.85	0.90 ~ 4.39 ~ 5.71
	Heating	Min.~Rated~Max.	kW	0.90 ~ 4.77 ~ 5.82	0.90 ~ 4.56 ~ 5.56
Running Current	Cooling	Rated	A	7.00	7.00
	Heating	Rated	A	7.30	7.30
EER / COP			W / W	2.98 / 3.25	3.05 / 3.40
SEER / SCOP			Wh / Wh	5.90 / 4.10	6.50 / 4.30
Seasonal Space Energy Efficiency($\eta_{s,c} / \eta_{s,h}$)			% / %	233.0 / 161.0	257.0 / 169.0
Seasonal Energy Label		Cooling / Heating	-	- / -	- / -
Annual Energy Consumption		Cooling / Heating	kWh	1,363 / 3244	1,237 / 2,931
Dehumidification Rate			ℓ/h	6.28	5.65
ODU Sound Pressure Level	Cooling	Rated	dB(A)	52	52
	Heating	Rated	dB(A)	53	53
ODU Sound Power Level	Cooling	Rated	dB(A)	69	69
	Heating	Rated	dB(A)	69	69
Piping Connections	Liquid	Outer Dia.	mm (inch)	Ø 9.52 (3/8)	Ø 9.52 (3/8)
	Gas	Outer Dia.	mm (inch)	Ø 15.88 (5/8)	Ø 15.88 (5/8)
Piping Length	Rated		m	7.5	7.5
	Min. / Max.		m	5.0 / 85.0	5.0 / 85.0
Refrigerant	Type		-	R32	R32
	GWP (Global Warming Potential)		-	675	675
	Precharged Amount		g	3,000	3,000
	t-CO ₂ eq.		-	2.025	2.025
	Control		-	EEV	EEV
	Chargeless-Pipe Length		m	20	20
	Additional Charging Volume		g/m	50	50

Note

- Due to our policy of innovation some specifications may be changed without notification.
- Wiring cable size must comply with the applicable local and national codes. And "Electric characteristics" chapter should be considered for electrical work and design. Especially the power cable and circuit breaker should be selected in accordance with that.
- Power factor could vary less than $\pm 1\%$ according to the operating conditions.
- Sound pressure level is measured on the rated condition in the anechoic rooms by ISO 3745 standard.
Sound power level is measured on the rated condition in the reverberation rooms by ISO 3741 standard.
Therefore, these values can be increased owing to ambient conditions during operation.
- Performances are based on the following conditions (It is accordance with EN14511) :
 - *Cooling : Indoor Ambient Temp. 27°CDB / 19°CWB, Outdoor Ambient Temp. 35°CDB / 24°CWB
 - *Heating : Indoor Ambient Temp. 20°CDB / 15°CWB, Outdoor Ambient Temp. 7°CDB / 6°CWB
 - Interconnected Pipe is standard length and difference of Elevation (Outdoor ~ Indoor Unit) is 0m.
- This product contains Fluorinated greenhouse gases.

2. Specifications

Combination	Outdoor unit			ZUUW48LA1 [UUD3 U30]	
	Indoor unit			ZTNW60GALA1 [UT60F NA0]	ZBNW60GM3A2 [UM60F N31]
Capacity	Cooling	Min.~Rated~Max.	kW	5.80 ~ 14.60~ 15.77	5.80 ~ 14.60 ~ 15.77
	Heating	Min.~Rated~Max.	kW	6.80 ~ 16.90 ~ 18.25	6.70 ~ 16.80 ~ 18.14
Power Input	Cooling	Min.~Rated~Max.	kW	1.00 ~ 5.21 ~ 5.84	1.00 ~ 4.95 ~ 5.54
	Heating	Min.~Rated~Max.	kW	1.00 ~ 5.12 ~ 5.89	0.90 ~ 4.60 ~ 5.29
Running Current	Cooling	Rated	A	8.10	7.70
	Heating	Rated	A	7.90	7.20
EER / COP			W / W	2.80 / 3.30	2.95 / 3.65
SEER / SCOP			Wh / Wh	6.20 / 4.20	5.60 / 4.00
Seasonal Space Energy Efficiency($\eta_{s,c} / \eta_{s,h}$)			% / %	245.0 / 165.0	221.0 / 157.0
Seasonal Energy Label		Cooling / Heating	-	- / -	- / -
Annual Energy Consumption		Cooling / Heating	kWh	1,413 / 3,167	1,564 / 3,325
Dehumidification Rate			ℓ/h	6.58	4.68
ODU Sound Pressure Level	Cooling	Rated	dB(A)	54	54
	Heating	Rated	dB(A)	54	54
ODU Sound Power Level	Cooling	Rated	dB(A)	71	71
	Heating	Rated	dB(A)	71	71
Piping Connections	Liquid	Outer Dia.	mm (inch)	Ø 9.52 (3/8)	Ø 9.52 (3/8)
	Gas	Outer Dia.	mm (inch)	Ø 15.88 (5/8)	Ø 15.88 (5/8)
Piping Length	Rated		m	7.5	7.5
	Min. / Max.		m	5.0 / 85.0	5.0 / 85.0
Refrigerant	Type		-	R32	R32
	GWP (Global Warming Potential)		-	675	675
	Precharged Amount		g	3,000	3,000
	t-CO ₂ eq.		-	2.025	2.025
	Control		-	EEV	EEV
	Chargeless-Pipe Length		m	20	20
	Additional Charging Volume		g/m	50	50

Note

- Due to our policy of innovation some specifications may be changed without notification.
- Wiring cable size must comply with the applicable local and national codes. And "Electric characteristics" chapter should be considered for electrical work and design. Especially the power cable and circuit breaker should be selected in accordance with that.
- Power factor could vary less than $\pm 1\%$ according to the operating conditions.
- Sound pressure level is measured on the rated condition in the anechoic rooms by ISO 3745 standard.
Sound power level is measured on the rated condition in the reverberation rooms by ISO 3741 standard.
Therefore, these values can be increased owing to ambient conditions during operation.
- Performances are based on the following conditions (It is accordance with EN14511) :
 - *Cooling : Indoor Ambient Temp. 27°CDB / 19°CWB, Outdoor Ambient Temp. 35°CDB / 24°CWB
 - *Heating : Indoor Ambient Temp. 20°CDB / 15°CWB, Outdoor Ambient Temp. 7°CDB / 6°CWB
 - Interconnected Pipe is standard length and difference of Elevation (Outdoor ~ Indoor Unit) is 0m.
- This product contains Fluorinated greenhouse gases.

2. Specifications

Combination	Outdoor unit			ZUUW48LA1 [UUD3 U30]
	Indoor unit			ZVNW60GM2A1 [UV60F N20]
Capacity	Cooling	Min.~Rated~Max.	kW	5.80 ~ 14.40 ~ 15.55
	Heating	Min.~Rated~Max.	kW	6.70 ~ 16.80 ~ 18.14
Power Input	Cooling	Min.~Rated~Max.	kW	1.10 ~ 5.33 ~ 5.97
	Heating	Min.~Rated~Max.	kW	1.10 ~ 5.60 ~ 6.44
Running Current	Cooling	Rated	A	8.20
	Heating	Rated	A	8.50
EER / COP			W / W	2.70 / 3.00
SEER / SCOP			Wh / Wh	5.70 / 4.10
Seasonal Space Energy Efficiency($\eta_{s,c} / \eta_{s,h}$)			% / %	225.0 / 161.0
Seasonal Energy Label		Cooling / Heating	-	- / -
Annual Energy Consumption		Cooling / Heating	kWh	1,516 / 3,244
Dehumidification Rate			ℓ/h	7.13
ODU Sound Pressure Level	Cooling	Rated	dB(A)	54
	Heating	Rated	dB(A)	54
ODU Sound Power Level	Cooling	Rated	dB(A)	71
	Heating	Rated	dB(A)	71
Piping Connections	Liquid	Outer Dia.	mm (inch)	Ø 9.52 (3/8)
	Gas	Outer Dia.	mm (inch)	Ø 15.88 (5/8)
Piping Length	Rated		m	7.5
	Min. / Max.		m	5.0 / 85.0
Refrigerant	Type		-	R32
	GWP (Global Warming Potential)		-	675
	Precharged Amount		g	3,000
	t-CO ₂ eq.		-	2.025
	Control		-	EEV
	Chargeless-Pipe Length		m	20
	Additional Charging Volume		g/m	50

Note

- Due to our policy of innovation some specifications may be changed without notification.
- Wiring cable size must comply with the applicable local and national codes. And "Electric characteristics" chapter should be considered for electrical work and design. Especially the power cable and circuit breaker should be selected in accordance with that.
- Power factor could vary less than $\pm 1\%$ according to the operating conditions.
- Sound pressure level is measured on the rated condition in the anechoic rooms by ISO 3745 standard.
Sound power level is measured on the rated condition in the reverberation rooms by ISO 3741 standard.
Therefore, these values can be increased owing to ambient conditions during operation.
- Performances are based on the following conditions (It is accordance with EN14511) :
 - *Cooling : Indoor Ambient Temp. 27°CDB / 19°CWB, Outdoor Ambient Temp. 35°CDB / 24°CWB
 - *Heating : Indoor Ambient Temp. 20°CDB / 15°CWB, Outdoor Ambient Temp. 7°CDB / 6°CWB
 - Interconnected Pipe is standard length and difference of Elevation (Outdoor ~ Indoor Unit) is 0m.
- This product contains Fluorinated greenhouse gases.

2. Specifications

■ Compact(1 Phase Inverter)

Combination	Outdoor unit			ZUUW12GA1 [UUA1 UL0]	
	Indoor unit			ZTNW18GQLA1 [CT18F NQ0]	ZBNW18GM1A2 [CM18F N11]
Capacity	Cooling	Min.~Rated~Max.	kW	1.80 ~ 5.00 ~ 5.50	1.80 ~ 5.00 ~ 5.60
	Heating	Min.~Rated~Max.	kW	2.10 ~ 5.20 ~ 5.70	2.20 ~ 5.50 ~ 6.70
Power Input	Cooling	Min.~Rated~Max.	kW	0.34 ~ 1.76 ~ 2.11	0.35 ~ 1.67 ~ 1.92
	Heating	Min.~Rated~Max.	kW	0.30 ~ 1.45 ~ 1.87	0.32 ~ 1.58 ~ 1.77
Running Current	Cooling	Rated	A	7.80	7.40
	Heating	Rated	A	6.40	7.00
EER / COP			W / W	2.85 / 3.60	3.00 / 3.50
SEER / SCOP			Wh / Wh	6.30 / 3.90	6.10 / 3.80
Seasonal Energy Label		Cooling / Heating	-	A++ / A	A++ / A
Annual Energy Consumption		Cooling / Heating	kWh	278 / 1,005	287 / 1,032
Dehumidification Rate			ℓ/h	1.84	1.23
ODU Sound Pressure Level	Cooling	Rated	dB(A)	49	49
	Heating	Rated	dB(A)	52	52
ODU Sound Power Level	Cooling	Rated	dB(A)	65	65
	Heating	Rated	dB(A)	-	-
Piping Connections	Liquid	Outer Dia.	mm (inch)	Ø 6.35 (1/4)	Ø 6.35 (1/4)
	Gas	Outer Dia.	mm (inch)	Ø 12.7 (1/2)	Ø 12.7 (1/2)
Piping Length	Rated		m	7.5	7.5
	Min. / Max.		m	5.0 / 30.0	5.0 / 30.0
Refrigerant	Type		-	R32	R32
	GWP (Global Warming Potential)		-	675	675
	Precharged Amount		g	1,000	1,000
	t-CO ₂ eq.		-	0.675	0.675
	Control		-	EEV	EEV
	Chargeless-Pipe Length		m	10	10
	Additional Charging Volume		g/m	20	20

Note

- Due to our policy of innovation some specifications may be changed without notification.
- Wiring cable size must comply with the applicable local and national codes. And "Electric characteristics" chapter should be considered for electrical work and design. Especially the power cable and circuit breaker should be selected in accordance with that.
- Power factor could vary less than ±1% according to the operating conditions.
- Sound pressure level is measured on the rated condition in the anechoic rooms by ISO 3745 standard.
Sound power level is measured on the rated condition in the reverberation rooms by ISO 3741 standard.
Therefore, these values can be increased owing to ambient conditions during operation.
- Performances are based on the following conditions (It is accordance with EN14511) :
 - *Cooling : Indoor Ambient Temp. 27°CDB / 19°CWB, Outdoor Ambient Temp. 35°CDB / 24°CWB
 - *Heating : Indoor Ambient Temp. 20°CDB / 15°CWB, Outdoor Ambient Temp. 7°CDB / 6°CWB
 - Interconnected Pipe is standard length and difference of Elevation (Outdoor ~ Indoor Unit) is 0m.
- This product contains Fluorinated greenhouse gases.

2. Specifications

Combination	Outdoor unit			ZUUW12GA1 [UUA1 UL0]	
	Indoor unit			ZBNW18GL6A1 [CL18F N60]	ZVNW18GM1A1 [UV18F N10]
Capacity	Cooling	Min.~Rated~Max.	kW	1.80 ~ 4.70 ~ 5.10	1.80 ~ 5.00 ~ 5.50
	Heating	Min.~Rated~Max.	kW	2.10 ~ 5.20 ~ 5.70	2.20 ~ 5.30 ~ 5.80
Power Input	Cooling	Min.~Rated~Max.	kW	0.34 ~ 1.62 ~ 1.99	0.32 ~ 1.62 ~ 1.93
	Heating	Min.~Rated~Max.	kW	0.30 ~ 1.53 ~ 1.99	0.30 ~ 1.44 ~ 1.86
Running Current	Cooling	Rated	A	7.20	7.20
	Heating	Rated	A	6.80	6.40
EER / COP			W / W	2.90 / 3.40	3.10 / 3.70
SEER / SCOP			Wh / Wh	5.10 / 3.80	6.60 / 4.60
Seasonal Energy Label		Cooling / Heating	-	A / A	A++ / A++
Annual Energy Consumption		Cooling / Heating	kWh	323 / 995	265 / 883
Dehumidification Rate			ℓ/h	1.47	1.67
ODU Sound Pressure Level	Cooling	Rated	dB(A)	49	49
	Heating	Rated	dB(A)	52	52
ODU Sound Power Level	Cooling	Rated	dB(A)	65	65
	Heating	Rated	dB(A)	-	-
Piping Connections	Liquid	Outer Dia.	mm (inch)	Ø 6.35 (1/4)	Ø 6.35 (1/4)
	Gas	Outer Dia.	mm (inch)	Ø 12.7 (1/2)	Ø 12.7 (1/2)
Piping Length	Rated		m	7.5	7.5
	Min. / Max.		m	5.0 / 30.0	5.0 / 30.0
Refrigerant	Type		-	R32	R32
	GWP (Global Warming Potential)		-	675	675
	Precharged Amount		g	1,000	1,000
	t-CO ₂ eq.		-	0.675	0.675
	Control		-	EEV	EEV
	Chargeless-Pipe Length		m	10	10
	Additional Charging Volume		g/m	20	20

Note

- Due to our policy of innovation some specifications may be changed without notification.
- Wiring cable size must comply with the applicable local and national codes. And "Electric characteristics" chapter should be considered for electrical work and design. Especially the power cable and circuit breaker should be selected in accordance with that.
- Power factor could vary less than ±1% according to the operating conditions.
- Sound pressure level is measured on the rated condition in the anechoic rooms by ISO 3745 standard.
Sound power level is measured on the rated condition in the reverberation rooms by ISO 3741 standard.
Therefore, these values can be increased owing to ambient conditions during operation.
- Performances are based on the following conditions (It is accordance with EN14511) :
 - *Cooling : Indoor Ambient Temp. 27°CDB / 19°CWB, Outdoor Ambient Temp. 35°CDB / 24°CWB
 - *Heating : Indoor Ambient Temp. 20°CDB / 15°CWB, Outdoor Ambient Temp. 7°CDB / 6°CWB
 - Interconnected Pipe is standard length and difference of Elevation (Outdoor ~ Indoor Unit) is 0m.
- This product contains Fluorinated greenhouse gases.

2. Specifications

Combination	Outdoor unit			ZUUW12GA1 [UUA1 UL0]
	Indoor unit			ZBNW18GMAA0 [CM18F NA0]
Capacity	Cooling	Min.~Rated~Max.	kW	1.80 ~ 5.00~5.50
	Heating	Min.~Rated~Max.	kW	2.20 ~ 5.50 ~ 6.30
Power Input	Cooling	Min.~Rated~Max.	kW	0.35 ~ 1.67 ~ 1.92
	Heating	Min.~Rated~Max.	kW	0.32 ~ 1.58 ~ 1.95
Running Current	Cooling	Rated	A	7.40
	Heating	Rated	A	7.00
EER / COP			W / W	3.00 / 3.50
SEER / SCOP			Wh / Wh	5.70 / 3.80
Seasonal Energy Label		Cooling / Heating	-	A+ / A
Annual Energy Consumption		Cooling / Heating	kWh	307 / 1,032
Dehumidification Rate			ℓ/h	1.23
ODU Sound Pressure Level	Cooling	Rated	dB(A)	49
	Heating	Rated	dB(A)	52
ODU Sound Power Level	Cooling	Rated	dB(A)	65
	Heating	Rated	dB(A)	-
Piping Connections	Liquid	Outer Dia.	mm (inch)	Ø 6.35 (1/4)
	Gas	Outer Dia.	mm (inch)	Ø 12.7 (1/2)
Piping Length	Rated		m	7.5
	Min. / Max.		m	5.0 / 30.0
Refrigerant	Type		-	R32
	GWP (Global Warming Potential)		-	675
	Precharged Amount		g	1,000
	t-CO ₂ eq.		-	0.675
	Control		-	EEV
	Chargeless-Pipe Length		m	10
	Additional Charging Volume		g/m	20

Note

- Due to our policy of innovation some specifications may be changed without notification.
- Wiring cable size must comply with the applicable local and national codes. And "Electric characteristics" chapter should be considered for electrical work and design. Especially the power cable and circuit breaker should be selected in accordance with that.
- Power factor could vary less than ±1% according to the operating conditions.
- Sound pressure level is measured on the rated condition in the anechoic rooms by ISO 3745 standard.
Sound power level is measured on the rated condition in the reverberation rooms by ISO 3741 standard.
Therefore, these values can be increased owing to ambient conditions during operation.
- Performances are based on the following conditions (It is accordance with EN14511) :
 - *Cooling : Indoor Ambient Temp. 27°CDB / 19°CWB, Outdoor Ambient Temp. 35°CDB / 24°CWB
 - *Heating : Indoor Ambient Temp. 20°CDB / 15°CWB, Outdoor Ambient Temp. 7°CDB / 6°CWB
 - Interconnected Pipe is standard length and difference of Elevation (Outdoor ~ Indoor Unit) is 0m.
- This product contains Fluorinated greenhouse gases.

2. Specifications

Combination	Outdoor unit			ZUUW24GA1 [UUB1 U20]	
	Indoor unit			ZTNW24GBLA1 [CT24F NB0]	ZBNW24GM1A2 [CM24F N11]
Capacity	Cooling	Min.~Rated~Max.	kW	2.70 ~ 6.80 ~ 7.50	2.70 ~ 6.80 ~ 7.50
	Heating	Min.~Rated~Max.	kW	3.00 ~ 7.50 ~ 8.60	3.00 ~ 7.40 ~ 8.50
Power Input	Cooling	Min.~Rated~Max.	kW	0.40 ~ 2.00 ~ 2.40	0.50 ~ 2.34 ~ 2.81
	Heating	Min.~Rated~Max.	kW	0.40 ~ 2.21 ~ 2.87	0.40 ~ 2.17 ~ 2.82
Running Current	Cooling	Rated	A	8.80	10.30
	Heating	Rated	A	9.60	9.70
EER / COP			W / W	3.40 / 3.39	2.91 / 3.41
SEER / SCOP			Wh / Wh	7.00 / 4.20	5.80 / 4.10
Seasonal Energy Label		Cooling / Heating	-	A++ / A+	A+ / A+
Annual Energy Consumption		Cooling / Heating	kWh	340 / 1,367	410 / 1,400
Dehumidification Rate			ℓ/h	2.61	2.48
ODU Sound Pressure Level	Cooling	Rated	dB(A)	48	48
	Heating	Rated	dB(A)	53	53
ODU Sound Power Level	Cooling	Rated	dB(A)	65	65
	Heating	Rated	dB(A)	-	-
Piping Connections	Liquid	Outer Dia.	mm (inch)	Ø 9.52 (3/8)	Ø 9.52 (3/8)
	Gas	Outer Dia.	mm (inch)	Ø 15.88 (5/8)	Ø 15.88 (5/8)
Piping Length	Rated		m	7.5	7.5
	Min. / Max.		m	5.0 / 35.0	5.0 / 35.0
Refrigerant	Type		-	R32	R32
	GWP (Global Warming Potential)		-	675	675
	Precharged Amount		g	1,200	1,200
	t-CO ₂ eq.		-	0.810	0.810
	Control		-	EEV	EEV
	Chargeless-Pipe Length		m	10	10
	Additional Charging Volume		g/m	40	40

Note

- Due to our policy of innovation some specifications may be changed without notification.
- Wiring cable size must comply with the applicable local and national codes. And "Electric characteristics" chapter should be considered for electrical work and design. Especially the power cable and circuit breaker should be selected in accordance with that.
- Power factor could vary less than ±1% according to the operating conditions.
- Sound pressure level is measured on the rated condition in the anechoic rooms by ISO 3745 standard.
Sound power level is measured on the rated condition in the reverberation rooms by ISO 3741 standard.
Therefore, these values can be increased owing to ambient conditions during operation.
- Performances are based on the following conditions (It is accordance with EN14511) :
 - *Cooling : Indoor Ambient Temp. 27°CDB / 19°CWB, Outdoor Ambient Temp. 35°CDB / 24°CWB
 - *Heating : Indoor Ambient Temp. 20°CDB / 15°CWB, Outdoor Ambient Temp. 7°CDB / 6°CWB
 - Interconnected Pipe is standard length and difference of Elevation (Outdoor ~ Indoor Unit) is 0m.
- This product contains Fluorinated greenhouse gases.

2. Specifications

Combination	Outdoor unit			ZUUW24GA1 [UUB1 U20]	
	Indoor unit			ZBNW24GL3A1 [CL24F N30]	ZVNW24GM1A1 [UV24F N10]
Capacity	Cooling	Min.~Rated~Max.	kW	2.70 ~ 6.80 ~ 7.50	2.70 ~ 6.80 ~ 7.50
	Heating	Min.~Rated~Max.	kW	3.00 ~ 7.50 ~ 8.60	2.90 ~ 7.30 ~ 8.40
Power Input	Cooling	Min.~Rated~Max.	kW	0.40 ~ 2.12 ~ 2.54	0.40 ~ 2.06 ~ 2.47
	Heating	Min.~Rated~Max.	kW	0.50 ~ 2.41 ~ 3.13	0.40 ~ 2.23 ~ 2.90
Running Current	Cooling	Rated	A	9.30	9.00
	Heating	Rated	A	10.50	9.70
EER / COP			W / W	3.21 / 3.11	3.30 / 3.28
SEER / SCOP			Wh / Wh	6.00 / 4.10	6.60 / 4.20
Seasonal Energy Label		Cooling / Heating	-	A+ / A+	A++ / A+
Annual Energy Consumption		Cooling / Heating	kWh	397 / 1,434	361 / 1,433
Dehumidification Rate			ℓ/h	2.35	2.42
ODU Sound Pressure Level	Cooling	Rated	dB(A)	48	48
	Heating	Rated	dB(A)	53	53
ODU Sound Power Level	Cooling	Rated	dB(A)	65	65
	Heating	Rated	dB(A)	-	-
Piping Connections	Liquid	Outer Dia.	mm (inch)	Ø 9.52 (3/8)	Ø 9.52 (3/8)
	Gas	Outer Dia.	mm (inch)	Ø 15.88 (5/8)	Ø 15.88 (5/8)
Piping Length	Rated		m	7.5	7.5
	Min. / Max.		m	5.0 / 35.0	5.0 / 35.0
Refrigerant	Type		-	R32	R32
	GWP (Global Warming Potential)		-	675	675
	Precharged Amount		g	1,200	1,200
	t-CO ₂ eq.		-	0.810	0.810
	Control		-	EEV	EEV
	Chargeless-Pipe Length		m	10	10
	Additional Charging Volume		g/m	40	40

Note

- Due to our policy of innovation some specifications may be changed without notification.
- Wiring cable size must comply with the applicable local and national codes. And "Electric characteristics" chapter should be considered for electrical work and design. Especially the power cable and circuit breaker should be selected in accordance with that.
- Power factor could vary less than ±1% according to the operating conditions.
- Sound pressure level is measured on the rated condition in the anechoic rooms by ISO 3745 standard.
Sound power level is measured on the rated condition in the reverberation rooms by ISO 3741 standard.
Therefore, these values can be increased owing to ambient conditions during operation.
- Performances are based on the following conditions (It is accordance with EN14511) :
 - *Cooling : Indoor Ambient Temp. 27°CDB / 19°CWB, Outdoor Ambient Temp. 35°CDB / 24°CWB
 - *Heating : Indoor Ambient Temp. 20°CDB / 15°CWB, Outdoor Ambient Temp. 7°CDB / 6°CWB
 - Interconnected Pipe is standard length and difference of Elevation (Outdoor ~ Indoor Unit) is 0m.
- This product contains Fluorinated greenhouse gases.

2. Specifications

Combination	Outdoor unit			ZUUW24GA1 [UUB1 U20]	
	Indoor unit			ZBNW24GMAA0 [CM24F NA0]	ZBNW30GMAA0 [UM30F NA0]
Capacity	Cooling	Min.~Rated~Max.	kW	2.70 ~ 6.80 ~ 7.50	3.00 ~ 7.50 ~ 8.30
	Heating	Min.~Rated~Max.	kW	3.00 ~ 7.40 ~ 8.20	3.20 ~ 8.00 ~ 8.80
Power Input	Cooling	Min.~Rated~Max.	kW	0.50 ~ 2.34 ~ 2.81	0.50 ~ 2.57 ~ 3.08
	Heating	Min.~Rated~Max.	kW	0.40 ~ 2.17 ~ 2.82	0.50 ~ 2.25 ~ 2.93
Running Current	Cooling	Rated	A	10.30	11.00
	Heating	Rated	A	9.70	9.70
EER / COP			W / W	2.91 / 3.41	2.92 / 3.56
SEER / SCOP			Wh / Wh	5.70 / 4.10	5.60 / 3.90
Seasonal Energy Label		Cooling / Heating	-	A+ / A+	A+ / A
Annual Energy Consumption		Cooling / Heating	kWh	418 / 1,400	469 / 1,544
Dehumidification Rate			ℓ/h	2.48	2.61
ODU Sound Pressure Level	Cooling	Rated	dB(A)	48	50
	Heating	Rated	dB(A)	53	54
ODU Sound Power Level	Cooling	Rated	dB(A)	65	67
	Heating	Rated	dB(A)	-	-
Piping Connections	Liquid	Outer Dia.	mm (inch)	Ø 9.52 (3/8)	Ø 9.52 (3/8)
	Gas	Outer Dia.	mm (inch)	Ø 15.88 (5/8)	Ø 15.88 (5/8)
Piping Length	Rated		m	7.5	7.5
	Min. / Max.		m	5.0 / 35.0	5.0 / 35.0
Refrigerant	Type		-	R32	R32
	GWP (Global Warming Potential)		-	675	675
	Precharged Amount		g	1,200	1,200
	t-CO ₂ eq.		-	0.810	0.810
	Control		-	EEV	EEV
	Chargeless-Pipe Length		m	10	10
	Additional Charging Volume		g/m	40	40

Note

- Due to our policy of innovation some specifications may be changed without notification.
- Wiring cable size must comply with the applicable local and national codes. And "Electric characteristics" chapter should be considered for electrical work and design. Especially the power cable and circuit breaker should be selected in accordance with that.
- Power factor could vary less than ±1% according to the operating conditions.
- Sound pressure level is measured on the rated condition in the anechoic rooms by ISO 3745 standard.
Sound power level is measured on the rated condition in the reverberation rooms by ISO 3741 standard.
Therefore, these values can be increased owing to ambient conditions during operation.
- Performances are based on the following conditions (It is accordance with EN14511) :
 - *Cooling : Indoor Ambient Temp. 27°CDB / 19°CWB, Outdoor Ambient Temp. 35°CDB / 24°CWB
 - *Heating : Indoor Ambient Temp. 20°CDB / 15°CWB, Outdoor Ambient Temp. 7°CDB / 6°CWB
 - Interconnected Pipe is standard length and difference of Elevation (Outdoor ~ Indoor Unit) is 0m.
- This product contains Fluorinated greenhouse gases.

2. Specifications

Combination	Outdoor unit			ZUUW24GA1 [UUB1 U20]	
	Indoor unit			ZJNW30GRLA1 [US30F NR0]	ZTNW30GBLA1 [UT30F NB0]
Capacity	Cooling	Min.~Rated~Max.	kW	3.00 ~ 7.50 ~ 8.30	3.00 ~ 7.50 ~ 8.30
	Heating	Min.~Rated~Max.	kW	3.10 ~ 7.70 ~ 8.50	3.20 ~ 7.90 ~ 8.70
Power Input	Cooling	Min.~Rated~Max.	kW	0.50 ~ 2.31 ~ 2.77	0.50 ~ 2.31 ~ 2.77
	Heating	Min.~Rated~Max.	kW	0.40 ~ 2.14 ~ 2.78	0.50 ~ 2.37 ~ 3.08
Running Current	Cooling	Rated	A	10.10	10.10
	Heating	Rated	A	9.30	10.40
EER / COP			W / W	3.25 / 3.60	3.25 / 3.34
SEER / SCOP			Wh / Wh	6.80 / 4.10	6.80 / 4.20
Seasonal Energy Label		Cooling / Heating	-	A++ / A+	A++ / A+
Annual Energy Consumption		Cooling / Heating	kWh	386 / 1,468	386 / 1,367
Dehumidification Rate			ℓ/h	3.01	3.10
ODU Sound Pressure Level	Cooling	Rated	dB(A)	50	50
	Heating	Rated	dB(A)	54	54
ODU Sound Power Level	Cooling	Rated	dB(A)	67	67
	Heating	Rated	dB(A)	-	-
Piping Connections	Liquid	Outer Dia.	mm (inch)	Ø 9.52 (3/8)	Ø 9.52 (3/8)
	Gas	Outer Dia.	mm (inch)	Ø 15.88 (5/8)	Ø 15.88 (5/8)
Piping Length	Rated		m	7.5	7.5
	Min. / Max.		m	5.0 / 35.0	5.0 / 35.0
Refrigerant	Type		-	R32	R32
	GWP (Global Warming Potential)		-	675	675
	Precharged Amount		g	1,200	1,200
	t-CO ₂ eq.		-	0.810	0.810
	Control		-	EEV	EEV
	Chargeless-Pipe Length		m	10	10
	Additional Charging Volume		g/m	40	40

Note

1. Due to our policy of innovation some specifications may be changed without notification.
2. Wiring cable size must comply with the applicable local and national codes. And "Electric characteristics" chapter should be considered for electrical work and design. Especially the power cable and circuit breaker should be selected in accordance with that.
3. Power factor could vary less than ±1% according to the operating conditions.
4. Sound pressure level is measured on the rated condition in the anechoic rooms by ISO 3745 standard.
Sound power level is measured on the rated condition in the reverberation rooms by ISO 3741 standard.
Therefore, these values can be increased owing to ambient conditions during operation.
5. Performances are based on the following conditions (It is accordance with EN14511) :
 - *Cooling : Indoor Ambient Temp. 27°CDB / 19°CWB, Outdoor Ambient Temp. 35°CDB / 24°CWB
 - *Heating : Indoor Ambient Temp. 20°CDB / 15°CWB, Outdoor Ambient Temp. 7°CDB / 6°CWB
 - Interconnected Pipe is standard length and difference of Elevation (Outdoor ~ Indoor Unit) is 0m.
6. This product contains Fluorinated greenhouse gases.

2. Specifications

Combination	Outdoor unit			ZUUW24GA1 [UUB1 U20]	
	Indoor unit			ZBNW30GM1A2 [UM30F N11]	ZVNW30GM1A1 [UV30F N10]
Capacity	Cooling	Min.~Rated~Max.	kW	3.00 ~ 7.50 ~ 8.30	3.00 ~ 7.50 ~ 8.30
	Heating	Min.~Rated~Max.	kW	3.20 ~ 8.00 ~ 8.80	3.20 ~ 8.00 ~ 8.80
Power Input	Cooling	Min.~Rated~Max.	kW	0.50 ~ 2.57 ~ 3.08	0.50 ~ 2.42 ~ 2.90
	Heating	Min.~Rated~Max.	kW	0.50 ~ 2.25 ~ 2.93	0.50 ~ 2.48 ~ 3.22
Running Current	Cooling	Rated	A	11.00	10.60
	Heating	Rated	A	9.70	10.80
EER / COP			W / W	2.92 / 3.56	3.10 / 3.23
SEER / SCOP			Wh / Wh	5.60 / 3.90	6.60 / 4.30
Seasonal Energy Label		Cooling / Heating	-	A+ / A	A++ / A+
Annual Energy Consumption		Cooling / Heating	kWh	469 / 1,544	398 / 1,433
Dehumidification Rate			ℓ/h	2.61	2.84
ODU Sound Pressure Level	Cooling	Rated	dB(A)	50	50
	Heating	Rated	dB(A)	54	54
ODU Sound Power Level	Cooling	Rated	dB(A)	67	67
	Heating	Rated	dB(A)	-	-
Piping Connections	Liquid	Outer Dia.	mm (inch)	Ø 9.52 (3/8)	Ø 9.52 (3/8)
	Gas	Outer Dia.	mm (inch)	Ø 15.88 (5/8)	Ø 15.88 (5/8)
Piping Length	Rated		m	7.5	7.5
	Min. / Max.		m	5.0 / 35.0	5.0 / 35.0
Refrigerant	Type		-	R32	R32
	GWP (Global Warming Potential)		-	675	675
	Precharged Amount		g	1,200	1,200
	t-CO ₂ eq.		-	0.810	0.810
	Control		-	EEV	EEV
	Chargeless-Pipe Length		m	10	10
	Additional Charging Volume		g/m	40	40

Note

- Due to our policy of innovation some specifications may be changed without notification.
- Wiring cable size must comply with the applicable local and national codes. And "Electric characteristics" chapter should be considered for electrical work and design. Especially the power cable and circuit breaker should be selected in accordance with that.
- Power factor could vary less than ±1% according to the operating conditions.
- Sound pressure level is measured on the rated condition in the anechoic rooms by ISO 3745 standard.
Sound power level is measured on the rated condition in the reverberation rooms by ISO 3741 standard.
Therefore, these values can be increased owing to ambient conditions during operation.
- Performances are based on the following conditions (It is accordance with EN14511) :
 - *Cooling : Indoor Ambient Temp. 27°CDB / 19°CWB, Outdoor Ambient Temp. 35°CDB / 24°CWB
 - *Heating : Indoor Ambient Temp. 20°CDB / 15°CWB, Outdoor Ambient Temp. 7°CDB / 6°CWB
 - Interconnected Pipe is standard length and difference of Elevation (Outdoor ~ Indoor Unit) is 0m.
- This product contains Fluorinated greenhouse gases.

2. Specifications

Combination	Outdoor unit			ZUUW30GA1 [UUC1 U40]	
	Indoor unit			ZJNW36GRLA1 [US36F NR0]	ZTNW36GALA1 [UT36F NAO]
Capacity	Cooling	Min.~Rated~Max.	kW	3.80 ~ 9.50 ~ 10.60	3.80 ~ 9.50 ~ 10.80
	Heating	Min.~Rated~Max.	kW	4.30 ~ 10.80 ~ 11.50	4.30 ~ 10.80 ~ 11.70
Power Input	Cooling	Min.~Rated~Max.	kW	0.60 ~ 3.06 ~ 3.67	0.60 ~ 2.79 ~ 3.57
	Heating	Min.~Rated~Max.	kW	0.60 ~ 3.00 ~ 3.72	0.60 ~ 2.77 ~ 3.30
Running Current	Cooling	Rated	A	13.60	12.40
	Heating	Rated	A	13.30	12.30
EER / COP			W / W	3.10 / 3.60	3.40 / 3.90
SEER / SCOP			Wh / Wh	6.40 / 4.10	6.70 / 4.30
Seasonal Energy Label		Cooling / Heating	-	A++ / A+	A++ / A+
Annual Energy Consumption		Cooling / Heating	kWh	520 / 1,980	496 / 1,823
Dehumidification Rate			ℓ/h	3.50	2.50
ODU Sound Pressure Level	Cooling	Rated	dB(A)	54	54
	Heating	Rated	dB(A)	56	56
ODU Sound Power Level	Cooling	Rated	dB(A)	70	70
	Heating	Rated	dB(A)	-	-
Piping Connections	Liquid	Outer Dia.	mm (inch)	Ø 9.52 (3/8)	Ø 9.52 (3/8)
	Gas	Outer Dia.	mm (inch)	Ø 15.88 (5/8)	Ø 15.88 (5/8)
Piping Length	Rated		m	7.5	7.5
	Min. / Max.		m	5.0 / 50.0	5.0 / 50.0
Refrigerant	Type		-	R32	R32
	GWP (Global Warming Potential)		-	675	675
	Precharged Amount		g	1,900	1,900
	t-CO ₂ eq.		-	1.283	1.283
	Control		-	EEV	EEV
	Chargeless-Pipe Length		m	20	20
	Additional Charging Volume		g/m	55	55

Note

- Due to our policy of innovation some specifications may be changed without notification.
- Wiring cable size must comply with the applicable local and national codes. And "Electric characteristics" chapter should be considered for electrical work and design. Especially the power cable and circuit breaker should be selected in accordance with that.
- Power factor could vary less than ±1% according to the operating conditions.
- Sound pressure level is measured on the rated condition in the anechoic rooms by ISO 3745 standard.
Sound power level is measured on the rated condition in the reverberation rooms by ISO 3741 standard.
Therefore, these values can be increased owing to ambient conditions during operation.
- Performances are based on the following conditions (It is accordance with EN14511) :
 - *Cooling : Indoor Ambient Temp. 27°CDB / 19°CWB, Outdoor Ambient Temp. 35°CDB / 24°CWB
 - *Heating : Indoor Ambient Temp. 20°CDB / 15°CWB, Outdoor Ambient Temp. 7°CDB / 6°CWB
 - Interconnected Pipe is standard length and difference of Elevation (Outdoor ~ Indoor Unit) is 0m.
- This product contains Fluorinated greenhouse gases.

2. Specifications

Combination	Outdoor unit			ZUUW30GA1 [UUC1 U40]	
	Indoor unit			ZBNW36GM2A2 [UM36F N21]	ZVNW36GM2A1 [UV36F N20]
Capacity	Cooling	Min.~Rated~Max.	kW	3.80 ~ 9.50 ~ 10.50	3.80 ~ 9.50 ~ 10.50
	Heating	Min.~Rated~Max.	kW	4.30 ~ 10.80 ~ 11.50	4.10 ~ 10.30 ~ 11.50
Power Input	Cooling	Min.~Rated~Max.	kW	0.60 ~ 3.16 ~ 3.86	0.70 ~ 3.28 ~ 3.87
	Heating	Min.~Rated~Max.	kW	0.60 ~ 3.03 ~ 3.48	0.60 ~ 2.78 ~ 3.45
Running Current	Cooling	Rated	A	14.00	14.60
	Heating	Rated	A	13.40	12.30
EER / COP			W / W	3.01 / 3.57	2.90 / 3.70
SEER / SCOP			Wh / Wh	5.90 / 4.00	6.10 / 4.20
Seasonal Energy Label		Cooling / Heating	-	A+ / A+	A++ / A+
Annual Energy Consumption		Cooling / Heating	kWh	564 / 1,924	545 / 1,833
Dehumidification Rate			ℓ/h	3.20	3.60
ODU Sound Pressure Level	Cooling	Rated	dB(A)	54	54
	Heating	Rated	dB(A)	56	56
ODU Sound Power Level	Cooling	Rated	dB(A)	70	70
	Heating	Rated	dB(A)	-	-
Piping Connections	Liquid	Outer Dia.	mm (inch)	Ø 9.52 (3/8)	Ø 9.52 (3/8)
	Gas	Outer Dia.	mm (inch)	Ø 15.88 (5/8)	Ø 15.88 (5/8)
Piping Length	Rated		m	7.5	7.5
	Min. / Max.		m	5.0 / 50.0	5.0 / 50.0
Refrigerant	Type		-	R32	R32
	GWP (Global Warming Potential)		-	675	675
	Precharged Amount		g	1,900	1,900
	t-CO ₂ eq.		-	1.283	1.283
	Control		-	EEV	EEV
	Chargeless-Pipe Length		m	20	20
	Additional Charging Volume		g/m	55	55

Note

- Due to our policy of innovation some specifications may be changed without notification.
- Wiring cable size must comply with the applicable local and national codes. And "Electric characteristics" chapter should be considered for electrical work and design. Especially the power cable and circuit breaker should be selected in accordance with that.
- Power factor could vary less than ±1% according to the operating conditions.
- Sound pressure level is measured on the rated condition in the anechoic rooms by ISO 3745 standard.
Sound power level is measured on the rated condition in the reverberation rooms by ISO 3741 standard.
Therefore, these values can be increased owing to ambient conditions during operation.
- Performances are based on the following conditions (It is accordance with EN14511) :
 - *Cooling : Indoor Ambient Temp. 27°CDB / 19°CWB, Outdoor Ambient Temp. 35°CDB / 24°CWB
 - *Heating : Indoor Ambient Temp. 20°CDB / 15°CWB, Outdoor Ambient Temp. 7°CDB / 6°CWB
 - Interconnected Pipe is standard length and difference of Elevation (Outdoor ~ Indoor Unit) is 0m.
- This product contains Fluorinated greenhouse gases.

2. Specifications

2.2 Outdoor Unit Specifications

■ 1 Phase Inverter

Model Name			Unit	ZUUW12GA1 [UUA1 UL0]
Power Supply			V, Ø, Hz	220-240, 1, 50
Power Supply Cable (included Earth)			No. x mm ²	3C x 1.5
Exterior	Color		-	Warm Gray
	RAL (Classic)		-	RAL 7044
Dimensions	Net	W x H x D	mm	770 x 545 x 288
	Shipping	W x H x D	mm	920 x 585 x 388
Weight	Net		kg	33.3
	Shipping		kg	36.0
Compressor	Type		-	Twin Rotary
	Model		Model x No.	DAT156MAD x 1
	Motor type		-	BLDC
	Motor Output		W x No.	1,500 x 1
	Oil Type		-	FW68D
Refrigerant	Oil Charge		cc x No.	400 x 1
	Type		-	R32
Heat Exchanger	Control		-	EEV
	(Row x Column x FPI) x No.		-	(2 x 24 x 14) x 1
Fan	Type		-	Propeller
	Air Flow Rate	Rated	m ³ /min x No.	28 x 1
Fan Motor	Type		-	BLDC
	Output		W x No.	43.0 x 1
Service Valve	Liquid	Outer Dia.	mm (inch)	Ø 6.35 (1/4)
	Gas	Outer Dia.	mm (inch)	Ø 9.52 (3/8)
Maximum Height Difference (ODU ~ IDU)		Max.	m	30

Note

- Due to our policy of innovation some specifications may be changed without notification.
- Wiring cable size must comply with the applicable local and national codes. And "Electric characteristics" chapter should be considered for electrical work and design. Especially the power cable and circuit breaker should be selected in accordance with that.
- Power factor could vary less than ±1% according to the operating conditions.
- Sound pressure level is measured on the rated condition in the anechoic rooms by ISO 3745 standard.
Sound power level is measured on the rated condition in the reverberation rooms by ISO 3741 standard.
Therefore, these values can be increased owing to ambient conditions during operation.
- Performances are based on the following conditions (It is accordance with EN14511) :
 - *Cooling : Indoor Ambient Temp. 27°CDB / 19°CWB, Outdoor Ambient Temp. 35°CDB / 24°CWB
 - *Heating : Indoor Ambient Temp. 20°CDB / 15°CWB, Outdoor Ambient Temp. 7°CDB / 6°CWB
 - Interconnected Pipe is standard length and difference of Elevation (Outdoor ~ Indoor Unit) is 0m.
- This product contains Fluorinated greenhouse gases.
 - * The piping connections may differ depending on the indoor unit. Check combinational specifications and installation manual.

2. Specifications

Model Name			Unit	ZUUW24GA1 [UUB1 U20]
Power Supply			V , Ø , Hz	220-240 , 1 , 50
Power Supply Cable (included Earth)			No. x mm ²	3C x 2.5
Exterior	Color		-	Warm Gray
	RAL (Classic)		-	RAL 7044
Dimensions	Net	W x H x D	mm	870 x 650 x 330
	Shipping	W x H x D	mm	1,046 x 713 x 461
Weight	Net		kg	45.0
	Shipping		kg	49.5
Compressor	Type		-	Twin Rotary
	Model		Model x No.	DKT208MAB x 1
	Motor type		-	BLDC
	Motor Output		W x No.	1,500 x 1
	Oil Type		-	FW68D
	Oil Charge		cc x No.	670 x 1
Refrigerant	Type		-	R32
	Control		-	EEV
Heat Exchanger	(Row x Column x FPI) x No.		-	(2 x 28 x 14) x 1
Fan	Type		-	Propeller
	Air Flow Rate	Rated	m ³ /min x No.	50 x 1
Fan Motor	Type		-	BLDC
	Output		W x No.	85.4 x 1
Service Valve	Liquid	Outer Dia.	mm (inch)	Ø 6.35 (1/4)
	Gas	Outer Dia.	mm (inch)	Ø 12.7 (1/2)
Maximum Height Difference (ODU ~ IDU)		Max.	m	30

Note

- Due to our policy of innovation some specifications may be changed without notification.
- Wiring cable size must comply with the applicable local and national codes. And "Electric characteristics" chapter should be considered for electrical work and design. Especially the power cable and circuit breaker should be selected in accordance with that.
- Power factor could vary less than $\pm 1\%$ according to the operating conditions.
- Sound pressure level is measured on the rated condition in the anechoic rooms by ISO 3745 standard.
Sound power level is measured on the rated condition in the reverberation rooms by ISO 3741 standard.
Therefore, these values can be increased owing to ambient conditions during operation.
- Performances are based on the following conditions (It is accordance with EN14511) :
 - *Cooling : Indoor Ambient Temp. 27°CDB / 19°CWB, Outdoor Ambient Temp. 35°CDB / 24°CWB
 - *Heating : Indoor Ambient Temp. 20°CDB / 15°CWB, Outdoor Ambient Temp. 7°CDB / 6°CWB
 - Interconnected Pipe is standard length and difference of Elevation (Outdoor ~ Indoor Unit) is 0m.
- This product contains Fluorinated greenhouse gases.
 - * The piping connections may differ depending on the indoor unit. Check combinational specifications and installation manual.

2. Specifications

Model Name			Unit	ZUUW30GA1 [UUC1 U40]
Power Supply			V , Ø , Hz	220-240 , 1 , 50
Power Supply Cable (included Earth)			No. x mm ²	3C x 2.5
Exterior	Color		-	Warm Gray
	RAL (Classic)		-	RAL 7044
Dimensions	Net	W x H x D	mm	950 x 834 x 330
	Shipping	W x H x D	mm	1,065 x 918 x 461
Weight	Net		kg	59.0
	Shipping		kg	66.5
Compressor	Type		-	Twin Rotary
	Model		Model x No.	DJT240MAA x 1
	Motor type		-	BLDC
	Motor Output		W x No.	2,020 x 1
	Oil Type		-	FW68D
	Oil Charge		cc x No.	900 x 1
Refrigerant	Type		-	R32
	Control		-	EEV
Heat Exchanger	(Row x Column x FPI) x No.		-	(2 x 38 x 14) x 1
Fan	Type		-	Propeller
	Air Flow Rate	Rated	m ³ /min x No.	58 x 1
Fan Motor	Type		-	BLDC
	Output		W x No.	124 x 1
Service Valve	Liquid	Outer Dia.	mm (inch)	Ø 9.52 (3/8)
	Gas	Outer Dia.	mm (inch)	Ø 15.88 (5/8)
Maximum Height Difference (ODU ~ IDU)		Max.	m	30

Note

- Due to our policy of innovation some specifications may be changed without notification.
- Wiring cable size must comply with the applicable local and national codes. And "Electric characteristics" chapter should be considered for electrical work and design. Especially the power cable and circuit breaker should be selected in accordance with that.
- Power factor could vary less than $\pm 1\%$ according to the operating conditions.
- Sound pressure level is measured on the rated condition in the anechoic rooms by ISO 3745 standard.
Sound power level is measured on the rated condition in the reverberation rooms by ISO 3741 standard.
Therefore, these values can be increased owing to ambient conditions during operation.
- Performances are based on the following conditions (It is accordance with EN14511) :
 - *Cooling : Indoor Ambient Temp. 27°CDB / 19°CWB, Outdoor Ambient Temp. 35°CDB / 24°CWB
 - *Heating : Indoor Ambient Temp. 20°CDB / 15°CWB, Outdoor Ambient Temp. 7°CDB / 6°CWB
 - Interconnected Pipe is standard length and difference of Elevation (Outdoor ~ Indoor Unit) is 0m.
- This product contains Fluorinated greenhouse gases.
 - * The piping connections may differ depending on the indoor unit. Check combinational specifications and installation manual.

2. Specifications

Model Name			Unit	ZUUW48GA1 [UUD1 U30]
Power Supply			V , Ø , Hz	220-240 , 1 , 50
Power Supply Cable (included Earth)			No. x mm ²	3C x 6.0
Exterior	Color		-	Warm Gray
	RAL (Classic)		-	RAL 7044
Dimensions	Net	W x H x D	mm	950 x 1,380 x 330
	Shipping	W x H x D	mm	1,140 x 1,549 x 461 (Wood)
				1,140 x 1,462 x 461 (EPS)
Weight	Net		kg	89.0
	Shipping		kg	102.0
Compressor	Type		-	LG Inverter Scroll
	Model		Model x No.	RJB036MAB × 1
	Motor type		-	BLDC
	Motor Output		W x No.	3,200 x 1
	Oil Type		-	FW68D
	Oil Charge		cc x No.	1,100 x 1
Refrigerant	Type		-	R32
	Control		-	EEV
Heat Exchanger	(Row x Column x FPI) x No.		-	(2 x 32 x 14) x 2
Fan	Type		-	Propeller
	Air Flow Rate	Rated	m ³ /min x No.	55 x 2
Fan Motor	Type		-	BLDC
	Output		W x No.	124 x 2
Service Valve	Liquid	Outer Dia.	mm (inch)	Ø 9.52 (3/8)
	Gas	Outer Dia.	mm (inch)	Ø 15.88 (5/8)
Maximum Height Difference (ODU ~ IDU)		Max.	m	30

Note

- Due to our policy of innovation some specifications may be changed without notification.
- Wiring cable size must comply with the applicable local and national codes. And "Electric characteristics" chapter should be considered for electrical work and design. Especially the power cable and circuit breaker should be selected in accordance with that.
- Power factor could vary less than ±1% according to the operating conditions.
- Sound pressure level is measured on the rated condition in the anechoic rooms by ISO 3745 standard.
Sound power level is measured on the rated condition in the reverberation rooms by ISO 3741 standard.
Therefore, these values can be increased owing to ambient conditions during operation.
- Performances are based on the following conditions (It is accordance with EN14511) :
 - *Cooling : Indoor Ambient Temp. 27°CDB / 19°CWB, Outdoor Ambient Temp. 35°CDB / 24°CWB
 - *Heating : Indoor Ambient Temp. 20°CDB / 15°CWB, Outdoor Ambient Temp. 7°CDB / 6°CWB
 - Interconnected Pipe is standard length and difference of Elevation (Outdoor ~ Indoor Unit) is 0m.
- This product contains Fluorinated greenhouse gases.
 - * The piping connections may differ depending on the indoor unit. Check combinational specifications and installation manual.

2. Specifications

■ 3 Phase Inverter

Model Name			Unit	ZUUW48LA1 [UUD3 U30]
Power Supply			V , Ø , Hz	380-415 , 3 , 50
Power Supply Cable (included Earth)			No. x mm ²	5C x 2.5
Exterior	Color		-	Warm Gray
	RAL (Classic)		-	RAL 7044
Dimensions	Net	W x H x D	mm	950 x 1,380 x 330
	Shipping	W x H x D	mm	1,140 x 1,549 x 461 (Wood) 1,140 x 1,462 x 461 (EPS)
Weight	Net		kg	89.0
	Shipping		kg	102.0
Compressor	Type		-	LG Inverter Scroll
	Model		Model x No.	RJB036MAB x 1
	Motor type		-	BLDC
	Motor Output		W x No.	3,200 x 1
	Oil Type		-	FW68D
	Oil Charge		cc x No.	1,100 x 1
Refrigerant	Type		-	R32
	Control		-	EEV
Heat Exchanger	(Row x Column x FPI) x No.		-	(2 x 32 x 14) x 2
Fan	Type		-	Propeller
	Air Flow Rate	Rated	m ³ /min x No.	55 x 2
Fan Motor	Type		-	BLDC
	Output		W x No.	124 x 2
Service Valve	Liquid	Outer Dia.	mm (inch)	Ø 9.52 (3/8)
	Gas	Outer Dia.	mm (inch)	Ø 15.88 (5/8)
Maximum Height Difference (ODU ~ IDU)		Max.	m	30

Note

- Due to our policy of innovation some specifications may be changed without notification.
- Wiring cable size must comply with the applicable local and national codes. And "Electric characteristics" chapter should be considered for electrical work and design. Especially the power cable and circuit breaker should be selected in accordance with that.
- Power factor could vary less than ±1% according to the operating conditions.
- Sound pressure level is measured on the rated condition in the anechoic rooms by ISO 3745 standard.
Sound power level is measured on the rated condition in the reverberation rooms by ISO 3741 standard.
Therefore, these values can be increased owing to ambient conditions during operation.
- Performances are based on the following conditions (It is accordance with EN14511) :
 - *Cooling : Indoor Ambient Temp. 27°CDB / 19°CWB, Outdoor Ambient Temp. 35°CDB / 24°CWB
 - *Heating : Indoor Ambient Temp. 20°CDB / 15°CWB, Outdoor Ambient Temp. 7°CDB / 6°CWB
 - Interconnected Pipe is standard length and difference of Elevation (Outdoor ~ Indoor Unit) is 0m.
- This product contains Fluorinated greenhouse gases.
 - * The piping connections may differ depending on the indoor unit. Check combinational specifications and installation manual.

3. Dimensions

◆ ZUUW12GA1 [UUA1 UL0]

[Unit: mm]

Chassis code : U18A
 DWG No. : TBW35446501_Rev01

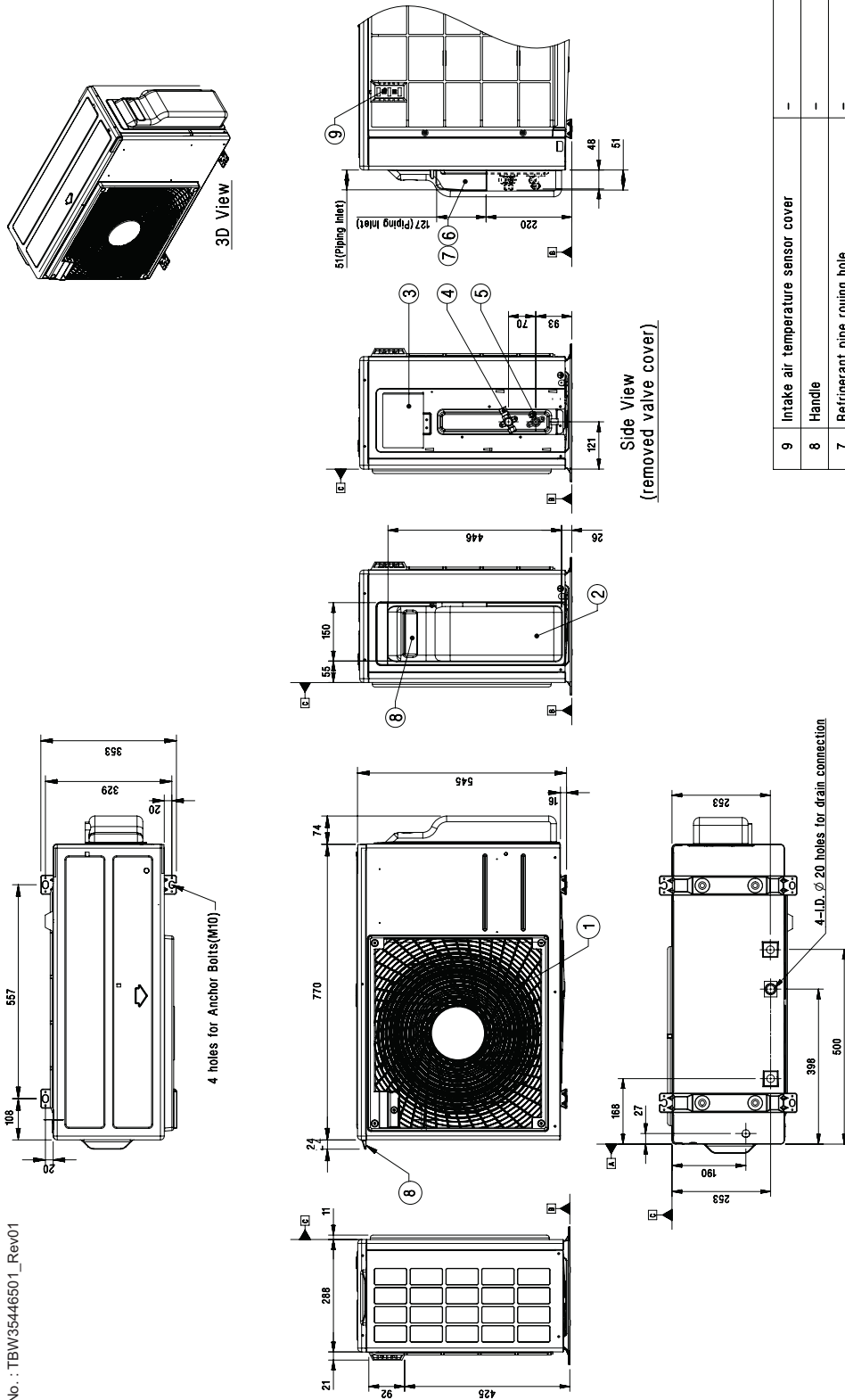

Symbols

- Datum line
- Refrigerant/Drain Piping Direction

Note

1. Unit should be installed in compliance with the installation manual in the product box.
2. Unit should be grounded in accordance with the local regulations or applicable national codes.
3. All electrical components and materials to be supplied from the site must comply with the local regulations or international codes.
4. Electric characteristics chapter should be considered for electrical work and design. Especially, the power cable and circuit breaker should be selected in accordance with that.

No.	Part Name	Description
9	Intake air temperature sensor cover	-
8	Handle	-
7	Refrigerant pipe routing hole	-
6	Power and Communication cable routing hole	-
5	Liquid Pipe connection	-
4	Gas Pipe connection	-
3	Power and communication cable connection	-
2	Control cover & SVC valve cover	-
1	Air Outlet	-

3. Dimensions

◆ ZUW24GA1 [UUB1 U20]

[Unit: mm]

Chassis code : U24A
 DWG No. : TBW35646501_Rev01

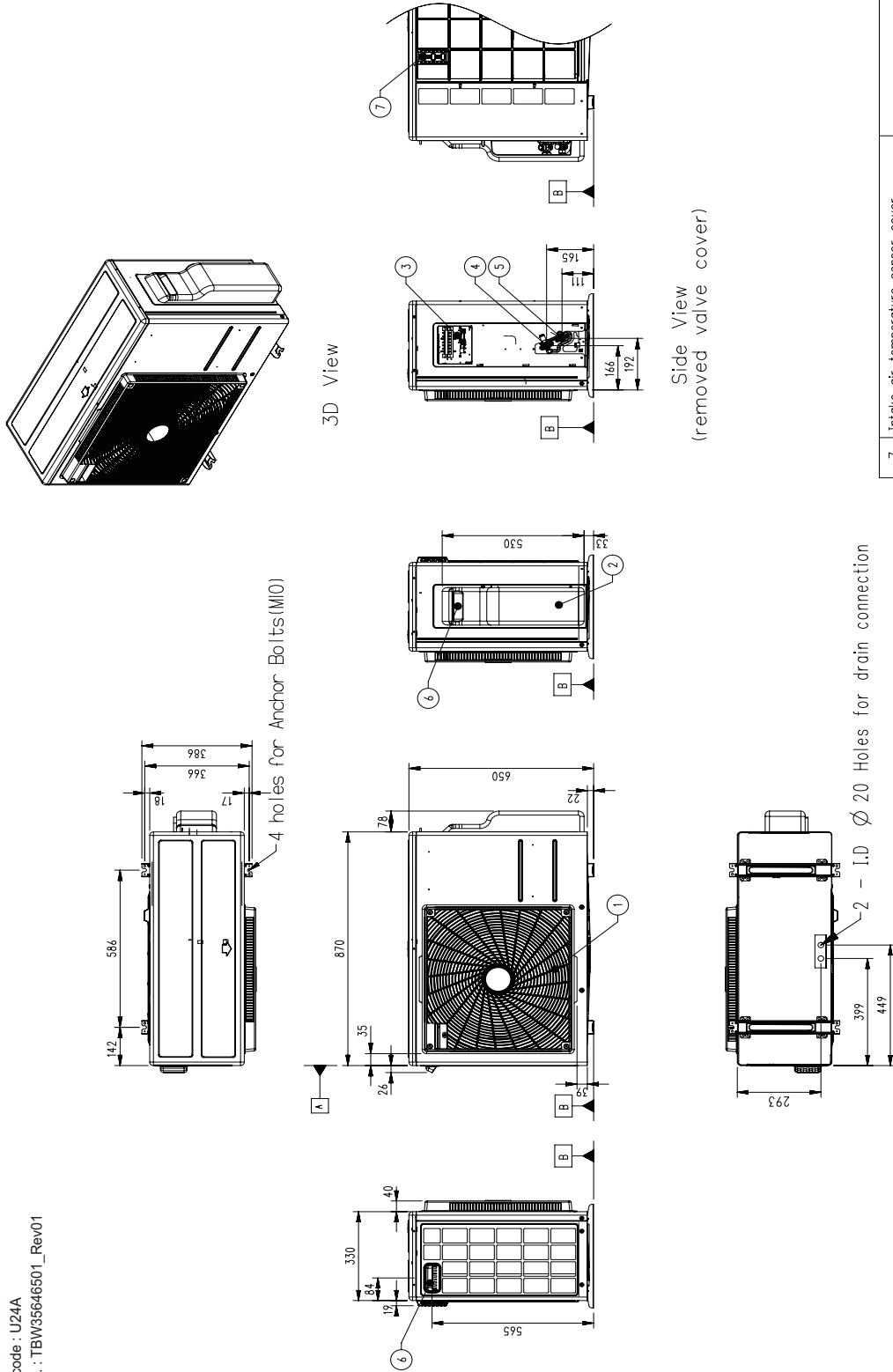

No.	Part Name	Description
7	Intake air temperature sensor cover	-
6	Handle	-
5	Liquid Pipe connection	-
4	Gas Pipe Connection	-
3	Power and communication cable connection	-
2	Control cover & SVC valve cover	-
1	Air Outlet	-

- Unit should be installed in compliance with the installation manual in the product box
- Unit should be grounded in accordance with the local regulations or applicable national codes
- All electrical components and materials to be supplied from the site must comply with the local regulations or international codes
- Electrical characteristics chapter should be considered for electrical work and design. Especially the power cable and circuit breaker should be selected in accordance with that

3. Dimensions

◆ ZUUW30GA1 [UUC1 U40]

[Unit: mm]

Chassis code : U36A
 DWG No. : TBW34666502_Rev01

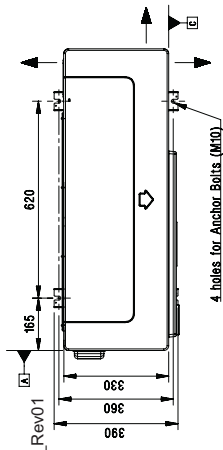

3D View

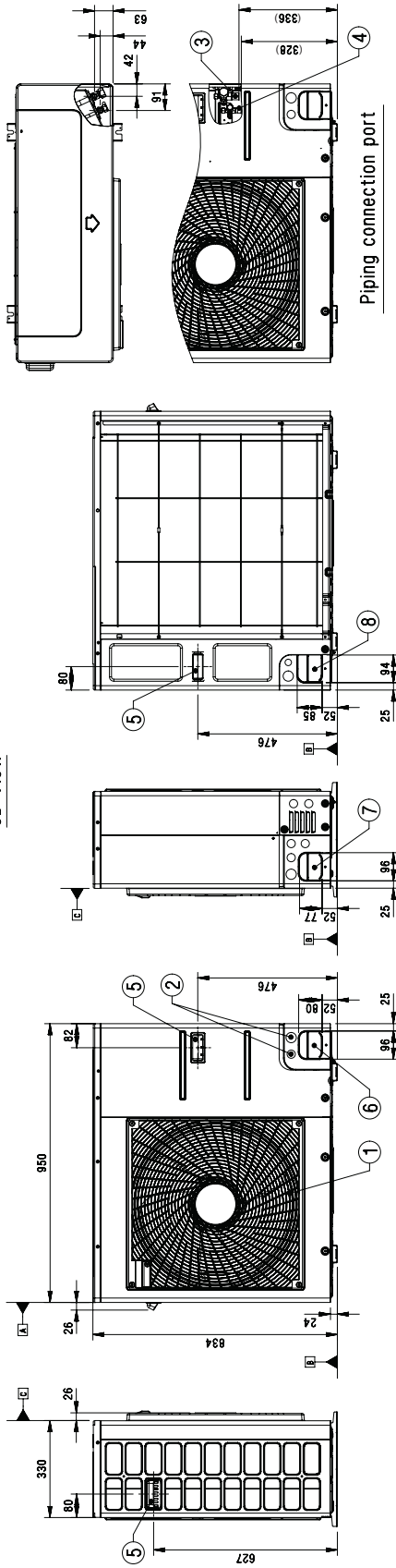
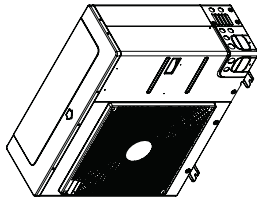

Piping connection port

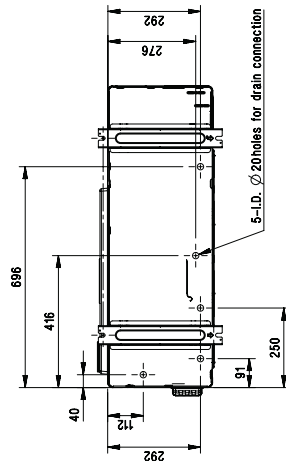

Symbols

- Piping Direction
- ▲ Datum line

Note

1. Unit should be installed in compliance with the installation manual in the product box.
2. Unit should be grounded in accordance with the local regulations or applicable national codes.
3. All electrical components and materials to be supplied from the site must comply with the local regulations or international codes.
4. Electrical characteristics chapter should be considered for electrical work and design. Especially the power cable and circuit breaker should be selected in accordance with that.

No.	Part Name	Description
8	Pipe routing hole (back)	-
7	Pipe routing hole (side)	-
6	Pipe routing hole (front)	-
5	Handle	-
4	Liquid Pipe Connection	Flare joint
3	Gas Pipe Connection	Flare joint
2	Power and communication cable Hole	-
1	Air Outlet	-

3. Dimensions

◆ ZUUW48GA1 [UUD1 U30], ZUUW48LA1 [UUD3 U30]

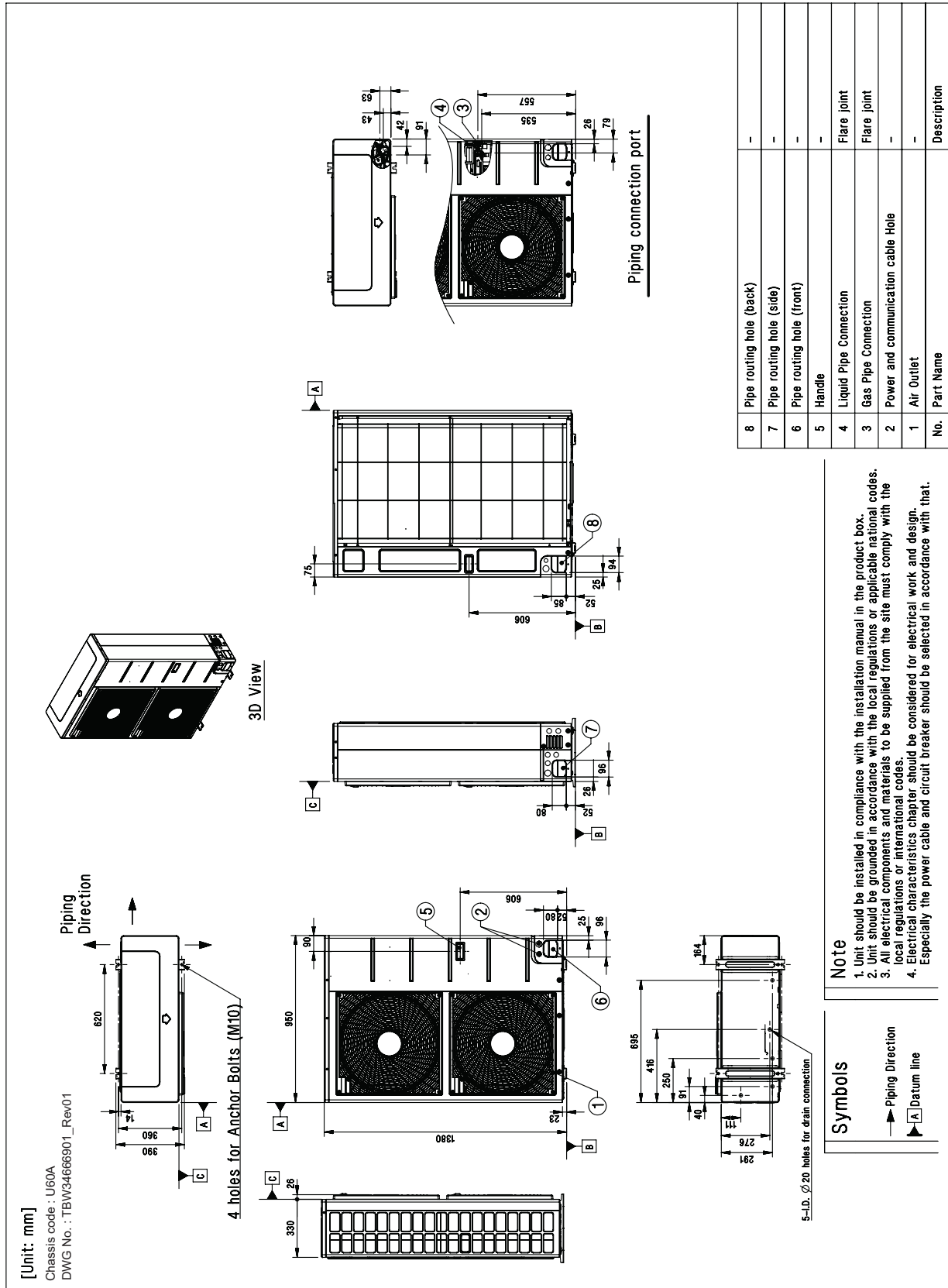

4. Piping Diagrams

◆ ZUW12GA1 [UUA1 UL0]

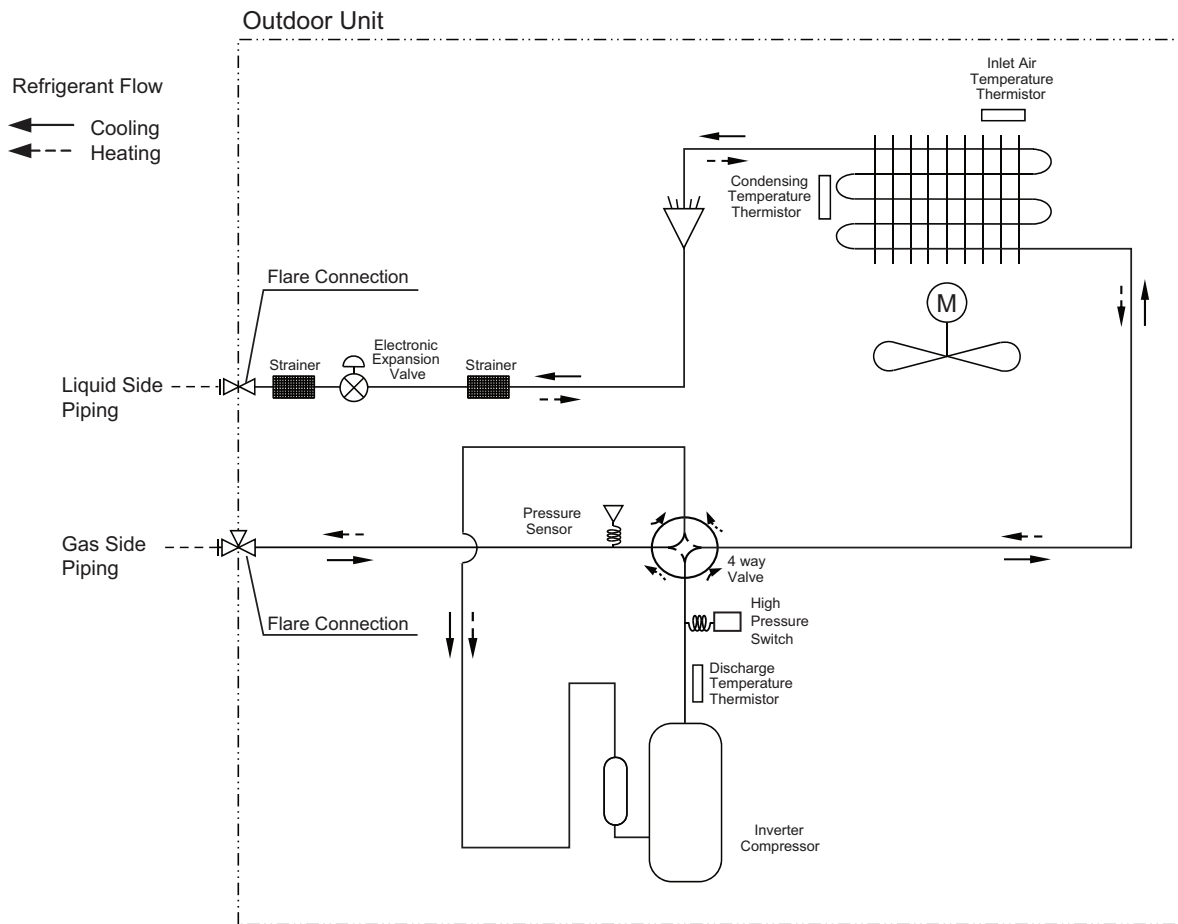

Description	PCB Connector
Discharge Temperature Thermistor	CN_DISCHARGE_BK
Inlet Air Temperature Thermistor	CN_TH1_WH
Condensing Temperature Thermistor	CN_TH1_WH
Pressure Sensor	CN_H_PRESS_RD
Pressure switch	CN_PRESS_WH

4. Piping Diagrams

◆ ZUUW24GA1 [UUB1 U20]

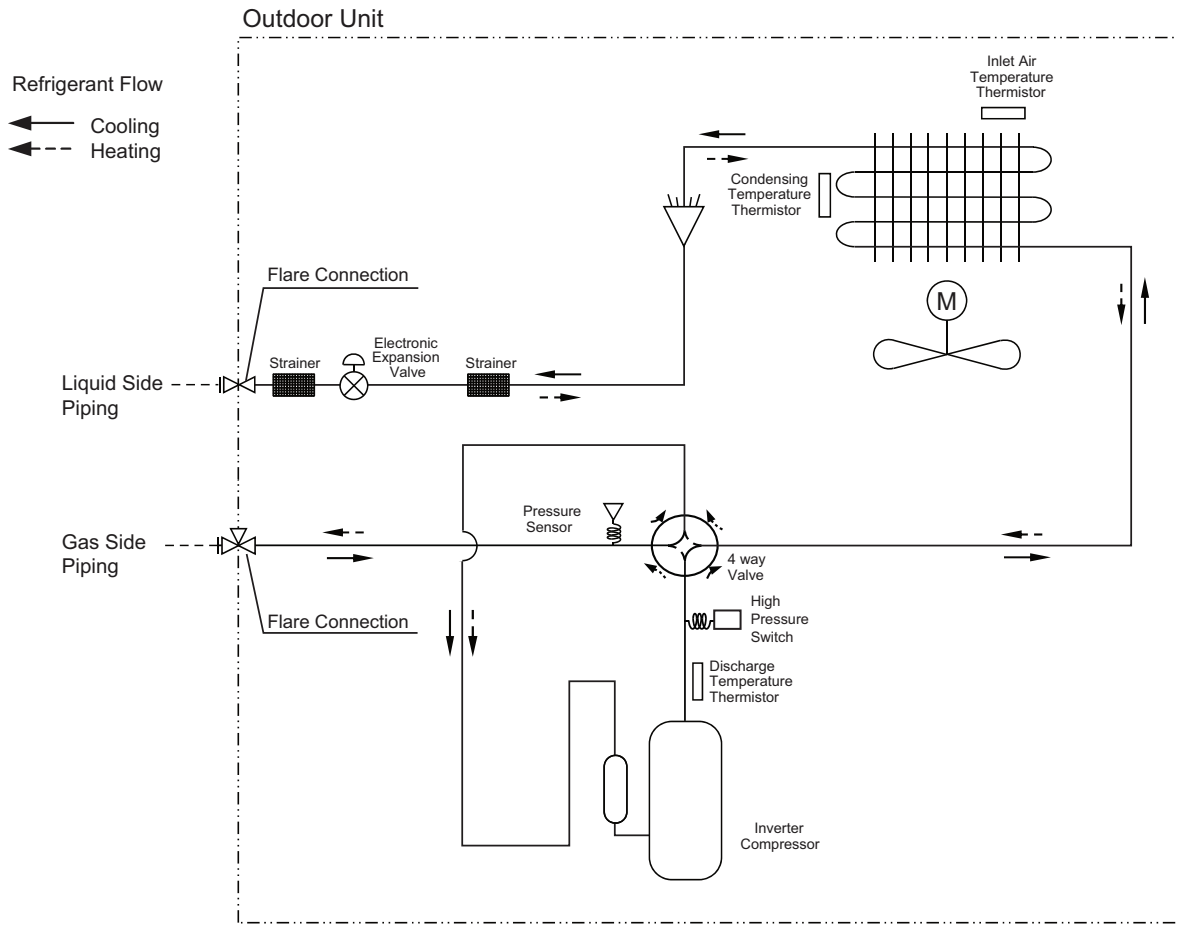

Description	PCB Connector
Electronic Expansion Valve	CN_EEV1
Discharge Temperature Thermistor	CN_DISCHARGE_BK
Inlet Air Temperature Thermistor	CN_AIR_YL
Condensing Temperature Thermistor	CN_MID_BR
Pressure sensor	CN_H_PRESS_RD
Pressure switch	CN_PRESS

4. Piping Diagrams

◆ ZUUW30GA1 [UUC1 U40], ZUUW48GA1 [UUD1 U30], ZUUW48LA1 [UUD3 U30]

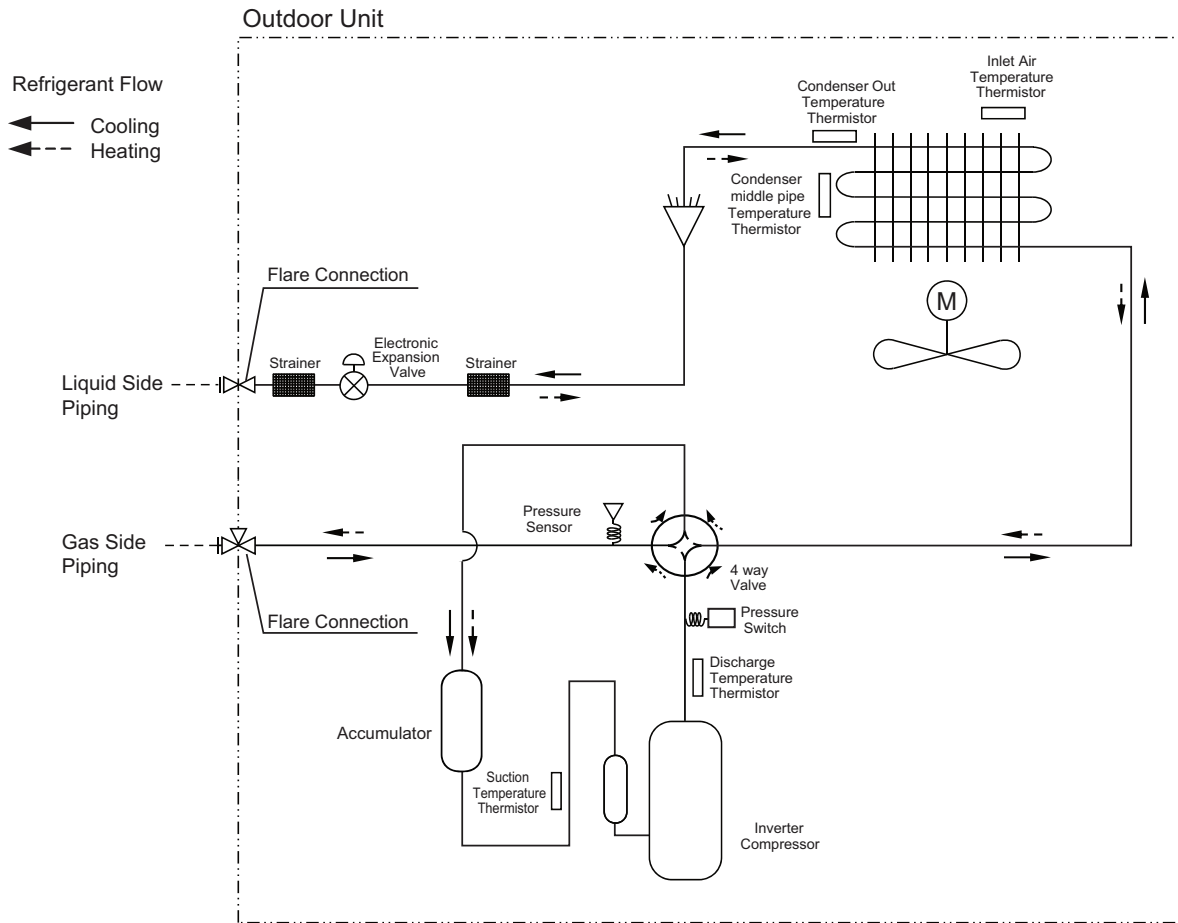

Description	PCB Connector	
	ZUUW30GA1 [UUC1 U40]	ZUUW48GA1 [UUD1 U30] ZUUW48LA1 [UUD3 U30]
Electronic Expansion Valve	CN_EEV1(WH)	CN_EEV1_WH
Suction Temperature Thermistor	CN_SUCTION(GN)	CN_SUCTION_GR
Discharge Temperature Thermistor	CN_DISCHARGE(BK)	CN_DISCHA_BK
Condenser Out Temperature Thermistor	CN_C_PIPE(VI)	CN_C_PIPE_VI
Inlet Air Temperature Thermistor	CN_AIR(YL)	CN_AIR_YL
Condensing Temperature Thermistor	CN_MID(BR)	CN_MID_BR
Pressure sensor	CN_H_PRESS(RD)	CN_H_PRESS_RD
Pressure switch	CN_PRESS_SW(GY)	CN_PRESS

5. Wiring Diagrams

◆ ZUUW12GA1 [UUA1 UL0]

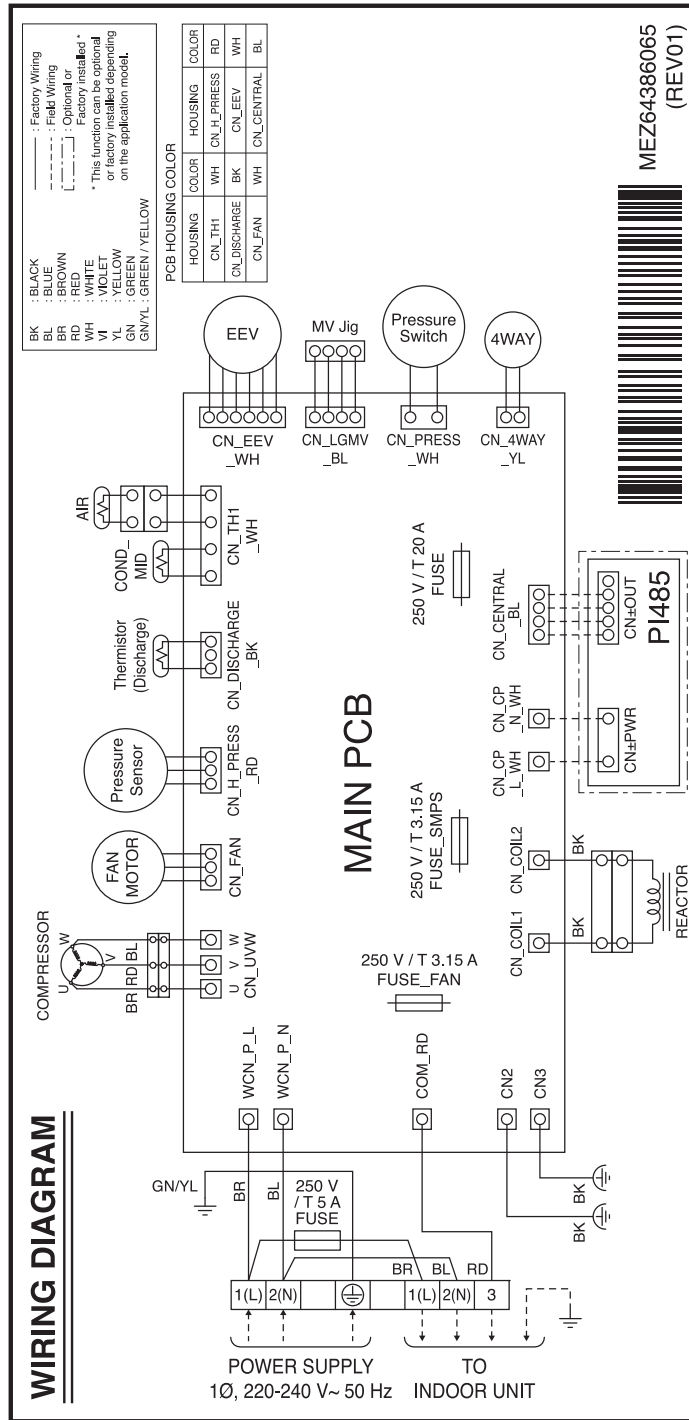

5. Wiring Diagrams

◆ ZUUW24GA1 [UUB1 U20]

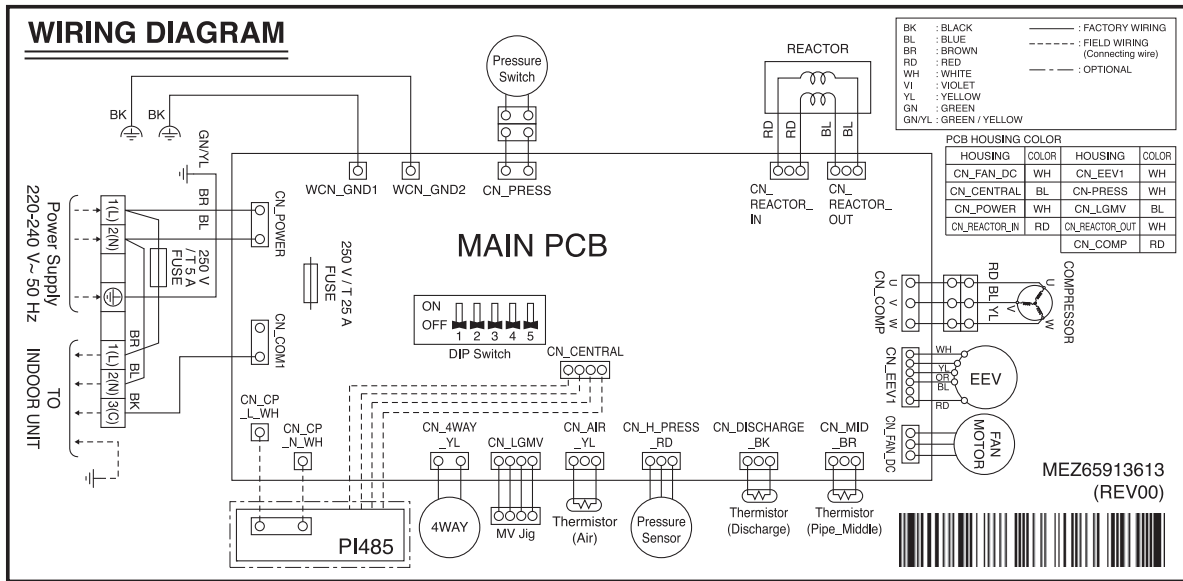

◆ ZUUW30GA1 [UUC1 U40]

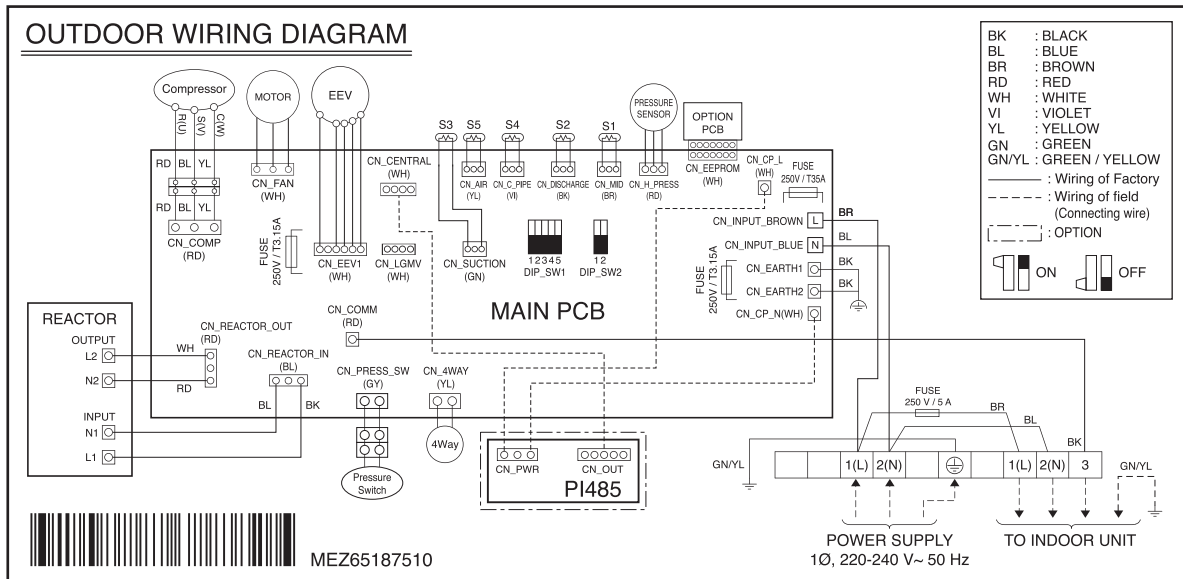

5. Wiring Diagrams

◆ ZUUW48GA1 [UUD1 U30]

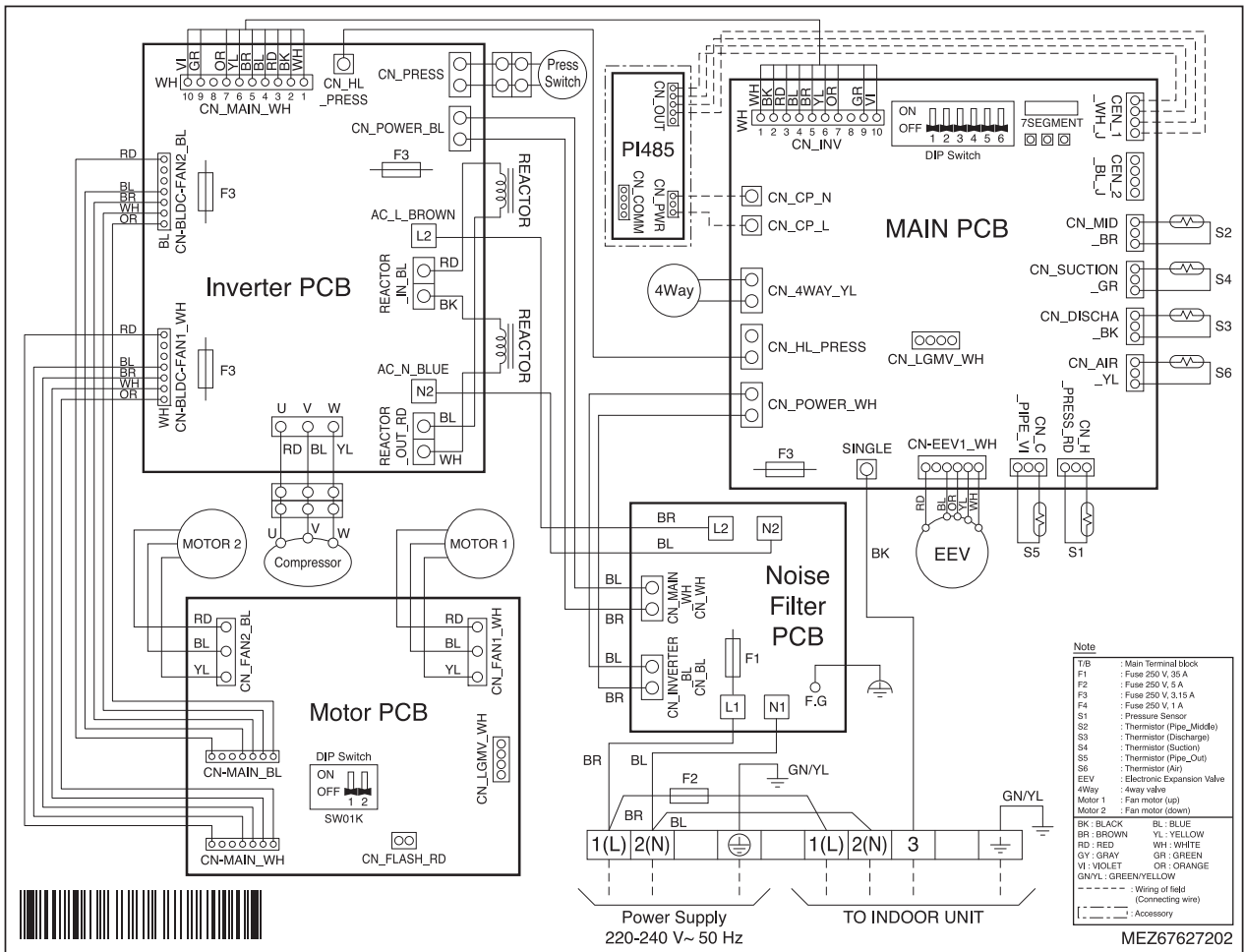

5. Wiring Diagrams

◆ ZUUW48LA1 [UD3 U30]

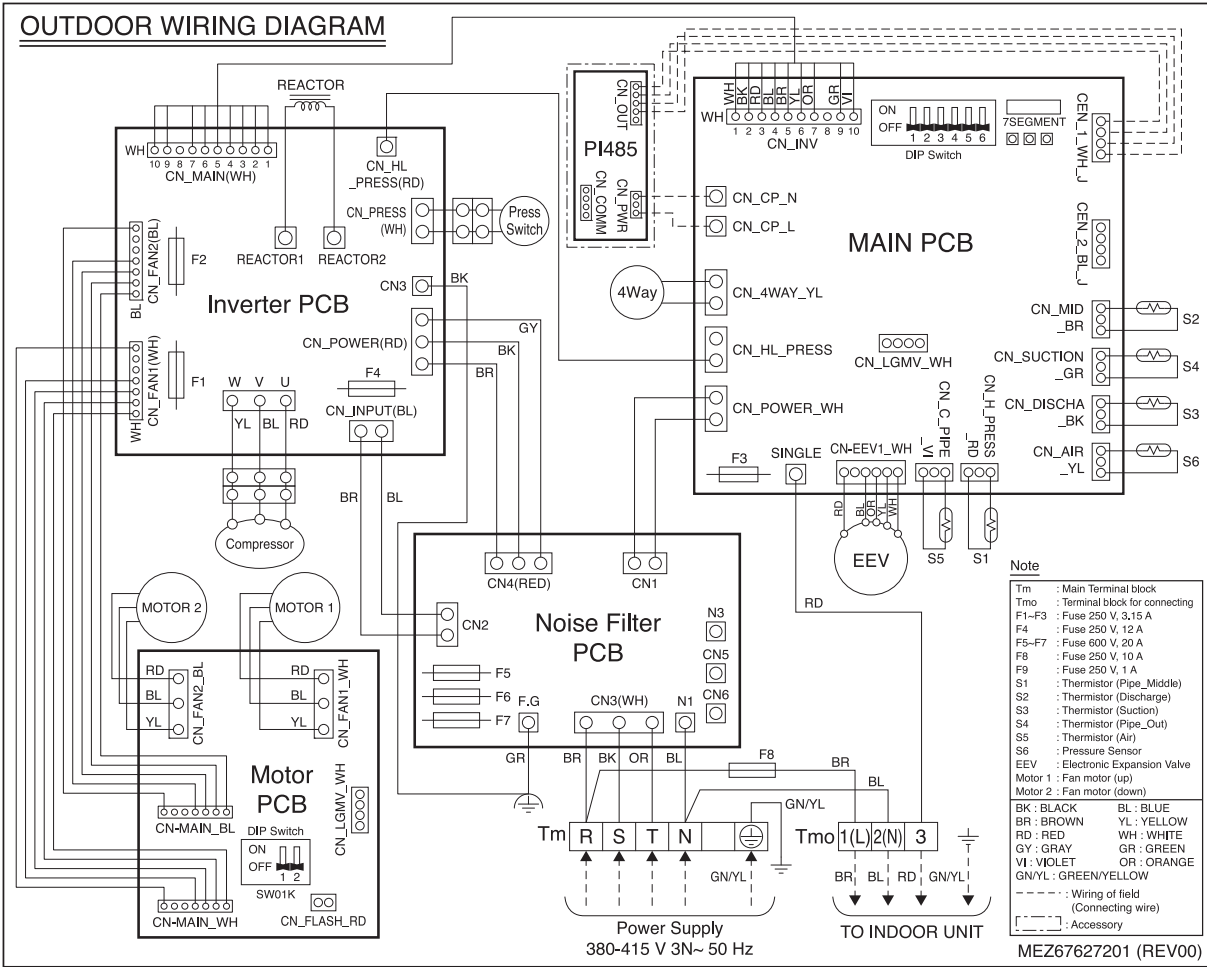

6. Capacity Tables

6.1 ZUUW12GA1 [UUA1 UL0]

■ Combined with 9k indoor units

◆ Cooling

Outdoor Air Temp.	Indoor Air Temperature : °CDB / °CWB																	
	20.0 / 14.0			22.0 / 16.0			25.0 / 18.0			27.0 / 19.0			30.0 / 22.0			32.0 / 24.0		
°CDB	TC	SHC	PI	TC	SHC	PI	TC	SHC	PI	TC	SHC	PI	TC	SHC	PI	TC	SHC	PI
20.0	1.75	1.53	0.29	2.19	1.81	0.38	2.53	2.08	0.48	2.79	2.21	0.50	3.04	2.17	0.51	3.24	2.15	0.52
25.0	1.66	1.49	0.32	2.10	1.76	0.42	2.44	2.03	0.52	2.69	2.17	0.53	2.95	2.13	0.55	3.14	2.10	0.56
32.0	1.52	1.43	0.36	1.97	1.70	0.46	2.30	1.97	0.57	2.56	2.10	0.59	2.81	2.06	0.61	3.01	2.04	0.61
35.0	1.47	1.40	0.38	1.91	1.67	0.48	2.24	1.94	0.59	2.50	2.08	0.61	2.76	2.04	0.63	2.95	2.01	0.63
40.0	1.37	1.35	0.41	1.81	1.62	0.51	2.15	1.89	0.63	2.40	2.03	0.65	2.66	1.99	0.67	2.85	1.96	0.67
43.0	1.32	1.30	0.43	1.76	1.60	0.53	2.09	1.87	0.65	2.35	2.00	0.67	2.60	1.96	0.69	2.80	1.94	0.69
46.0	1.26	1.25	0.45	1.70	1.57	0.55	2.04	1.84	0.68	2.32	2.00	0.69	2.58	1.96	0.71	2.77	1.93	0.72
48.0	1.22	1.21	0.47	1.66	1.55	0.56	2.00	1.82	0.77	2.30	2.00	0.79	2.56	1.96	0.81	2.76	1.93	0.81

◆ Heating

Outdoor Air Temp.	Indoor Air Temperature : °CDB									
	16.0		18.0		20.0		22.0		24.0	
°CWB	TC	PI	TC	PI	TC	PI	TC	PI	TC	PI
-20.0	1.91	0.57	1.89	0.62	1.88	0.67	1.86	0.73	1.85	0.78
-15.0	2.35	0.67	2.33	0.72	2.32	0.77	2.30	0.82	2.29	0.88
-10.0	2.79	0.77	2.78	0.82	2.76	0.87	2.74	0.92	2.73	0.97
-5.0	3.23	0.87	3.22	0.92	3.20	0.97	3.07	0.92	2.94	0.88
0.0	3.54	0.97	3.37	0.92	3.20	0.87	3.07	0.83	2.94	0.78
6.0	3.54	0.83	3.37	0.79	3.20	0.75	3.07	0.71	2.94	0.68
10.0	3.54	0.77	3.37	0.72	3.20	0.67	3.07	0.64	2.94	0.60
15.0	3.54	0.67	3.37	0.62	3.20	0.57	3.07	0.54	2.94	0.51
18.0	3.54	0.61	3.37	0.56	3.20	0.51	3.07	0.48	2.94	0.46

Note

1. DB : Dry bulb temperature(°C), WB : Wet bulb temperature(°C)
2. TC : Total capacity(kW), SHC : Sensible Heating Capacity(kW)
3. PI : Power Input (kW, Compressor + indoor fan motor + outdoor fan motor)
4. All capacities are net. A deduction (cooling mode) or an addition (heating mode) of Capacity due to operating heat of indoor unit motor is reflected.
5. Direct interpolation is permissible. Do not extrapolate.
6. Rated capacities and power inputs are based on standard temperature and piping conditions, and it can be found on specifications table. Except for rated value, the performance is not guaranteed.
7. In accordance with the test standard(or nations), the rating will vary slightly.

■ Correction factor due to the indoor unit combination

◆ Cooling

H-Inverter		ZTNW09GQLH1 [UT09FH NQ0]	
Indoor Unit		TC	PI
Max.		1.60	1.61
Rated		1.00	1.00

Standard									
Indoor Unit	ZTNW09GRLA1 [CT09F NR0]		ZBNW09GL5A1 [CL09F N50]		ZQNW09GALA1 [UQ09F NA0]		ZMNW09GSJC0 [MJ09PC NSJ]		
	TC	PI	TC	PI	TC	PI	TC	PI	
Max.	1.30	1.43	1.30	1.52	1.35	1.50	1.28	1.38	
Rated	1.00	0.98	1.00	1.05	1.04	1.03	1.00	0.95	

◆ Heating

H-Inverter		ZTNW09GQLH1 [UT09FH NQ0]	
Indoor Unit		TC	PI
Max.		1.41	1.41
Rated		1.00	1.00

Standard									
Indoor Unit	ZTNW09GRLA1 [CT09F NR0]		ZBNW09GL5A1 [CL09F N50]		ZQNW09GALA1 [UQ09F NA0]		ZMNW09GSJC0 [MJ09PC NSJ]		
	TC	PI	TC	PI	TC	PI	TC	PI	
Max.	1.15	1.18	1.26	1.65	1.21	1.44	1.16	1.13	
Rated	1.00	0.99	1.09	1.27	0.97	0.96	1.00	1.04	

Note

Except for standard temperature condition, the capacity is not guaranteed.

6. Capacity Tables

Combined with 12k indoor units

Cooling

Outdoor Air Temp.	Indoor Air Temperature : °CDB / °CWB																	
	20.0 / 14.0			22.0 / 16.0			25.0 / 18.0			27.0 / 19.0			30.0 / 22.0			32.0 / 24.0		
°CDB	TC	SHC	PI	TC	SHC	PI	TC	SHC	PI	TC	SHC	PI	TC	SHC	PI	TC	SHC	PI
20.0	2.38	2.09	0.46	2.99	2.46	0.61	3.44	2.82	0.76	3.79	3.01	0.79	4.14	2.95	0.82	4.40	2.92	0.82
25.0	2.26	2.03	0.51	2.86	2.39	0.66	3.31	2.76	0.82	3.66	2.95	0.85	4.01	2.89	0.88	4.27	2.86	0.88
32.0	2.07	1.94	0.58	2.67	2.31	0.73	3.13	2.68	0.90	3.48	2.86	0.93	3.82	2.81	0.96	4.09	2.77	0.97
35.0	2.00	1.90	0.61	2.60	2.27	0.76	3.05	2.64	0.94	3.40	2.82	0.97	3.75	2.77	1.00	4.01	2.73	1.00
40.0	1.87	1.84	0.66	2.47	2.21	0.81	2.92	2.58	1.00	3.27	2.76	1.03	3.62	2.71	1.06	3.88	2.67	1.07
43.0	1.79	1.77	0.69	2.39	2.17	0.84	2.85	2.54	1.04	3.19	2.72	1.07	3.54	2.67	1.10	3.80	2.63	1.10
46.0	1.71	1.69	0.72	2.31	2.13	0.88	2.77	2.50	1.07	3.15	2.72	1.10	3.51	2.67	1.13	3.77	2.63	1.14
48.0	1.66	1.64	0.74	2.26	2.11	0.90	2.72	2.48	1.22	3.13	2.72	1.25	3.48	2.66	1.28	3.75	2.63	1.29

Heating

Outdoor Air Temp.	Indoor Air Temperature : °CDB											
	16.0		18.0		20.0		22.0		24.0			
°CWB	TC	PI	TC	PI	TC	PI	TC	PI	TC	PI		
-20.0	2.45	0.79	2.42	0.85	2.40	0.92	2.38	1.00	2.36	1.08		
-15.0	3.01	0.92	2.99	0.99	2.97	1.06	2.95	1.13	2.93	1.20		
-10.0	3.58	1.06	3.56	1.13	3.53	1.19	3.52	1.26	3.50	1.33		
-5.0	4.14	1.19	4.12	1.26	4.10	1.33	3.94	1.27	3.77	1.20		
0.0	4.54	1.33	4.32	1.26	4.10	1.19	3.94	1.14	3.77	1.08		
6.0	4.54	1.13	4.32	1.08	4.10	1.03	3.94	0.98	3.77	0.93		
10.0	4.54	1.06	4.32	0.99	4.10	0.92	3.94	0.87	3.77	0.83		
15.0	4.54	0.92	4.32	0.85	4.10	0.79	3.94	0.74	3.77	0.70		
18.0	4.54	0.84	4.32	0.77	4.10	0.70	3.94	0.67	3.77	0.63		

Note

1. DB : Dry bulb temperature(°C), WB : Wet bulb temperature(°C)
2. TC : Total capacity(kW), SHC : Sensible Heating Capacity(kW)
3. PI : Power Input (kW, Compressor + indoor fan motor + outdoor fan motor)
4. All capacities are net. A deduction (cooling mode) or an addition (heating mode) of Capacity due to operating heat of indoor unit motor is reflected.
5. Direct interpolation is permissible. Do not extrapolate.
6. Rated capacities and power inputs are based on standard temperature and piping conditions, and it can be found on specifications table. Except for rated value, the performance is not guaranteed.
7. In accordance with the test standard(or nations), the rating will vary slightly.

Correction factor due to the indoor unit combination

Cooling

H-Inverter							
Indoor Unit	ZTNW12GQLH1 [UT12FH NQ0]		ZBNW12GL5H1 [UL12FH N50]		ZBNW12GM1H1 [UM12FH N10]		
	TC	PI	TC	PI	TC	PI	
Max.	1.41	1.84	1.38	1.90	1.50	1.99	
Rated	1.00	1.00	1.00	1.08	1.03	1.06	

Standard								
Indoor Unit	ZTNW12GRLA1 [CT12F NR0]		ZBNW12GL5A1 [CL12F N50]		ZQNW12GALA1 [UQ12F NA0]		ZMNW12GSJC0 [MJ12PC NSJ]	
	TC	PI	TC	PI	TC	PI	TC	PI
Max.	1.32	1.67	1.39	1.90	1.18	1.31	1.18	1.53
Rated	1.00	0.97	1.00	1.09	1.03	1.03	1.03	1.03

Heating

H-Inverter							
Indoor Unit	ZTNW12GQLH1 [UT12FH NQ0]		ZBNW12GL5H1 [UL12FH N50]		ZBNW12GM1H1 [UM12FH N10]		
	TC	PI	TC	PI	TC	PI	
Max.	1.41	1.82	1.20	1.58	1.41	1.80	
Rated	1.00	1.00	0.98	1.05	0.98	0.95	

Standard								
Indoor Unit	ZTNW12GRLA1 [CT12F NR0]		ZBNW12GL5A1 [CL12F N50]		ZQNW12GALA1 [UQ12F NA0]		ZMNW12GSJC0 [MJ12PC NSJ]	
	TC	PI	TC	PI	TC	PI	TC	PI
Max.	1.21	1.52	1.20	1.58	1.05	1.53	1.07	1.44
Rated	1.00	1.05	0.98	1.21	0.98	1.02	0.98	0.97

Note

Except for standard temperature condition, the capacity is not guaranteed.

6. Capacity Tables

■ Combined with 18k indoor units

◆ Cooling

Outdoor Air Temp.	Indoor Air Temperature : °CDB / °CWB																	
	20.0 / 14.0			22.0 / 16.0			25.0 / 18.0			27.0 / 19.0			30.0 / 22.0			32.0 / 24.0		
°CDB	TC	SHC	PI	TC	SHC	PI	TC	SHC	PI	TC	SHC	PI	TC	SHC	PI	TC	SHC	PI
20.0	3.51	2.88	0.84	4.39	3.39	1.11	5.06	3.90	1.38	5.57	4.15	1.43	6.08	4.08	1.48	6.47	4.03	1.49
25.0	3.32	2.80	0.92	4.20	3.30	1.20	4.87	3.81	1.49	5.38	4.07	1.54	5.89	3.99	1.59	6.28	3.94	1.60
32.0	3.05	2.68	1.05	3.93	3.18	1.33	4.60	3.69	1.64	5.11	3.95	1.69	5.62	3.87	1.75	6.01	3.82	1.76
35.0	2.94	2.63	1.10	3.82	3.13	1.38	4.49	3.64	1.71	5.00	3.90	1.76	5.51	3.82	1.81	5.90	3.77	1.82
40.0	2.74	2.54	1.20	3.57	3.00	1.42	4.00	3.31	1.43	4.33	3.43	1.47	4.78	3.36	1.52	5.13	3.31	1.53
43.0	2.63	2.49	1.25	3.43	2.92	1.25	3.71	3.10	1.27	3.92	3.14	1.30	4.35	3.08	1.34	4.67	3.03	1.35
46.0	2.52	2.44	1.08	3.28	2.85	1.09	3.41	2.90	1.10	3.52	2.85	1.13	3.91	2.79	1.16	4.21	2.75	1.17
48.0	2.44	2.40	0.97	3.19	2.79	0.98	3.22	2.75	0.99	3.25	2.65	1.02	3.62	2.60	1.04	3.90	2.56	1.05

◆ Heating

Outdoor Air Temp.	Indoor Air Temperature : °CDB									
	16.0		18.0		20.0		22.0		24.0	
°CWB	TC	PI	TC	PI	TC	PI	TC	PI	TC	PI
-20.0	1.63	0.53	1.61	0.65	1.59	0.77	1.58	0.96	1.56	1.15
-15.0	2.53	0.77	2.51	0.89	2.50	1.02	2.48	1.18	2.46	1.34
-10.0	3.43	1.02	3.42	1.14	3.40	1.26	3.38	1.40	3.37	1.54
-5.0	4.33	1.26	4.32	1.38	4.30	1.50	4.28	1.62	4.27	1.74
0.0	5.24	1.50	5.22	1.62	5.20	1.74	4.99	1.64	4.78	1.54
6.0	5.76	1.60	5.48	1.52	5.20	1.45	4.99	1.38	4.78	1.31
10.0	5.76	1.50	5.48	1.38	5.20	1.26	4.99	1.20	4.78	1.15
15.0	5.76	1.26	5.48	1.14	5.20	1.02	4.99	0.98	4.78	0.95
18.0	5.76	1.11	5.48	0.99	5.20	0.87	4.99	0.85	4.78	0.83

Note

1. DB : Dry bulb temperature(°C), WB : Wet bulb temperature(°C)
2. TC : Total capacity(kW), SHC : Sensible Heating Capacity(kW)
3. PI : Power Input (kW, Compressor + indoor fan motor + outdoor fan motor)
4. All capacities are net. A deduction (cooling mode) or an addition (heating mode) of Capacity due to operating heat of indoor unit motor is reflected.
5. Direct interpolation is permissible. Do not extrapolate.
6. Rated capacities and power inputs are based on standard temperature and piping conditions, and it can be found on specifications table. Except for rated value, the performance is not guaranteed.
7. In accordance with the test standard(or nations), the rating will vary slightly.

■ Correction factor due to the indoor unit combination

◆ Cooling

Compact										
Indoor Unit	ZTNW18GQLA1 [CT18F NQ0]		ZBNW18GM1A2 [CM18F N11]		ZBNW18GMAA0 [CM18F NA0]		ZVNW18GM1A1 [UV18F N10]		ZBNW18GL6A1 [CL18F N60]	
	TC	PI	TC	PI	TC	PI	TC	PI	TC	PI
Max.	1.10	1.20	1.12	1.09	1.10	1.09	1.10	1.10	1.02	1.13
Rated	1.00	1.00	1.00	0.95	1.00	0.95	1.00	0.92	0.94	0.92

◆ Heating

Compact										
Indoor Unit	ZTNW18GQLA1 [CT18F NQ0]		ZBNW18GM1A2 [CM18F N11]		ZBNW18GMAA0 [CM18F NA0]		ZVNW18GM1A1 [UV18F N10]		ZBNW18GL6A1 [CL18F N60]	
	TC	PI	TC	PI	TC	PI	TC	PI	TC	PI
Max.	1.10	1.29	1.29	1.22	1.21	1.34	1.12	1.28	1.10	1.37
Rated	1.00	1.00	1.06	1.09	1.06	1.09	1.02	0.99	1.00	1.06

Note

Except for standard temperature condition, the capacity is not guaranteed.

6. Capacity Tables

6.2 ZUUW24GA1 [UUB1 U20]

Combined with 18k indoor units

Cooling

Outdoor Air Temp.	Indoor Air Temperature : °CDB / °CWB																	
	20.0 / 14.0			22.0 / 16.0			25.0 / 18.0			27.0 / 19.0			30.0 / 22.0			32.0 / 24.0		
°CDB	TC	SHC	PI	TC	SHC	PI	TC	SHC	PI	TC	SHC	PI	TC	SHC	PI	TC	SHC	PI
20.0	3.51	2.63	0.60	4.39	3.09	0.79	5.06	3.55	0.98	5.57	3.78	1.02	6.08	3.72	1.05	6.47	3.67	1.06
25.0	3.32	2.55	0.65	4.20	3.01	0.85	4.87	3.47	1.06	5.38	3.71	1.09	5.89	3.64	1.13	6.28	3.59	1.14
32.0	3.05	2.44	0.74	3.93	2.90	0.94	4.60	3.37	1.17	5.11	3.60	1.20	5.62	3.53	1.24	6.01	3.49	1.25
35.0	2.94	2.39	0.78	3.82	2.86	0.98	4.49	3.32	1.21	5.00	3.55	1.25	5.51	3.48	1.29	5.90	3.44	1.30
40.0	2.74	2.31	0.85	3.63	2.78	1.05	4.30	3.24	1.29	4.81	3.47	1.33	5.32	3.41	1.37	5.71	3.36	1.37
43.0	2.63	2.27	0.89	3.51	2.73	1.09	4.18	3.19	1.34	4.69	3.43	1.37	5.21	3.36	1.41	5.59	3.31	1.42
46.0	2.52	2.22	0.93	3.40	2.68	1.13	4.07	3.15	1.38	4.73	3.49	1.42	5.26	3.42	1.46	5.66	3.37	1.47
48.0	2.44	2.19	0.95	3.32	2.65	1.15	3.99	3.12	1.52	4.75	3.53	1.56	5.29	3.46	1.60	5.70	3.41	1.61

Heating

Outdoor Air Temp.	Indoor Air Temperature : °CDB									
	16.0		18.0		20.0		22.0		24.0	
°CWB	TC	PI	TC	PI	TC	PI	TC	PI	TC	PI
-20.0	4.13	1.13	4.09	1.23	4.06	1.32	4.03	1.43	4.00	1.53
-15.0	4.71	1.32	4.67	1.41	4.64	1.51	4.61	1.61	4.58	1.71
-10.0	5.29	1.51	5.25	1.60	5.22	1.69	5.19	1.79	5.16	1.88
-5.0	5.87	1.69	5.83	1.79	5.80	1.88	5.77	1.79	5.74	1.71
0.0	6.42	1.88	6.11	1.79	5.80	1.69	5.57	1.61	5.34	1.53
6.0	6.42	1.62	6.11	1.54	5.80	1.47	5.57	1.40	5.34	1.32
10.0	6.42	1.51	6.11	1.41	5.80	1.32	5.57	1.25	5.34	1.18
15.0	6.42	1.32	6.11	1.23	5.80	1.13	5.57	1.07	5.34	1.01
18.0	6.42	1.21	6.11	1.11	5.80	1.02	5.57	0.96	5.34	0.90

Note

1. DB : Dry bulb temperature(°C), WB : Wet bulb temperature(°C)
2. TC : Total capacity(kW), SHC : Sensible Heating Capacity(kW)
3. PI : Power Input (kW, Compressor + indoor fan motor + outdoor fan motor)
4. All capacities are net. A deduction (cooling mode) or an addition (heating mode) of Capacity due to operating heat of indoor unit motor is reflected.
5. Direct interpolation is permissible. Do not extrapolate.
6. Rated capacities and power inputs are based on standard temperature and piping conditions, and it can be found on specifications table. Except for rated value, the performance is not guaranteed.
7. In accordance with the test standard(or nations), the rating will vary slightly.

Correction factor due to the indoor unit combination

Cooling

H-Inverter									
Indoor Unit	Z1NW18GDLH1 [UT18FH NB0]		ZBNW18GM1H1 [UM18FH N10]		ZBNW18GL3H1 [UL18FH N30]		ZVNW18GM1H1 [UV18FH N10]		
	TC	PI	TC	PI	TC	PI	TC	PI	
Max.	1.20	1.35	1.20	1.36	1.20	1.50	1.20	1.38	
Rated	1.00	1.00	1.00	1.01	1.00	1.11	1.00	1.02	

Standard														
Indoor Unit	Z1NW18GDLA1 [CT18F NQ0]		ZBNW18GM1A2 [CM18F N11]		ZBNW18GMAA0 [CM18F NAO]		ZBNW18GL6A1 [CL18F N60]		ZVNW18GM1A1 [UV18F N10]		ZQNW18GALA1 [UQ18F NAO]		ZMNW18GSKC0 [MJ18PC NSK]	
	TC	PI	TC	PI	TC	PI	TC	PI	TC	PI	TC	PI	TC	PI
Max.	1.15	1.76	1.15	1.49	0.95	1.10	1.15	1.51	1.15	1.49	1.15	1.96	1.15	1.60
Rated	1.00	1.26	1.00	1.06	1.00	1.06	1.00	1.08	1.00	1.06	1.00	1.40	1.00	1.14

Heating

H-Inverter									
Indoor Unit	Z1NW18GDLH1 [UT18FH NB0]		ZBNW18GM1H1 [UM18FH N10]		ZBNW18GL3H1 [UL18FH N30]		ZVNW18GM1H1 [UV18FH N10]		
	TC	PI	TC	PI	TC	PI	TC	PI	
Max.	1.20	1.35	1.20	1.37	1.20	1.44	1.20	1.45	
Rated	1.00	1.00	1.00	1.01	1.00	1.06	1.00	1.06	

Standard														
Indoor Unit	Z1NW18GDLA1 [CT18F NQ0]		ZBNW18GM1A2 [CM18F N11]		ZBNW18GMAA0 [CM18F NAO]		ZBNW18GL6A1 [CL18F N60]		ZVNW18GM1A1 [UV18F N10]		ZQNW18GALA1 [UQ18F NAO]		ZMNW18GSKC0 [MJ18PC NSK]	
	TC	PI	TC	PI	TC	PI	TC	PI	TC	PI	TC	PI	TC	PI
Max.	1.13	1.45	1.15	1.68	0.93	1.24	1.15	1.69	1.15	1.68	0.93	1.43	1.05	1.33
Rated	0.98	1.03	1.00	1.20	0.95	1.01	1.00	1.20	1.00	1.20	0.84	1.06	1.00	1.16

Note

Except for standard temperature condition, the capacity is not guaranteed.

6. Capacity Tables

■ Combined with 24k indoor units

◆ Cooling

Outdoor Air Temp.	Indoor Air Temperature : °CDB / °CWB																	
	20.0 / 14.0			22.0 / 16.0			25.0 / 18.0			27.0 / 19.0			30.0 / 22.0			32.0 / 24.0		
°CDB	TC	SHC	PI	TC	SHC	PI	TC	SHC	PI	TC	SHC	PI	TC	SHC	PI	TC	SHC	PI
20.0	4.77	3.67	0.95	5.97	4.32	1.26	6.88	4.97	1.57	7.58	5.29	1.63	8.27	5.20	1.69	8.80	5.13	1.70
25.0	4.51	3.56	1.04	5.71	4.21	1.36	6.62	4.86	1.69	7.32	5.18	1.75	8.01	5.09	1.81	8.54	5.03	1.82
32.0	4.15	3.41	1.19	5.35	4.06	1.51	6.26	4.71	1.86	6.96	5.03	1.93	7.65	4.94	1.99	8.18	4.87	2.00
35.0	3.99	3.35	1.25	5.19	3.99	1.57	6.11	4.64	1.94	6.80	4.96	2.00	7.49	4.87	2.06	8.02	4.81	2.07
40.0	3.73	3.24	1.36	4.93	3.88	1.68	5.85	4.53	2.06	6.54	4.86	2.12	7.09	4.66	2.18	7.60	4.60	2.20
43.0	3.58	3.17	1.42	4.78	3.82	1.74	5.69	4.47	2.24	6.26	4.69	2.30	6.84	4.54	2.37	7.35	4.48	2.38
46.0	3.42	3.11	1.48	4.62	3.75	1.80	5.54	4.40	2.42	5.97	4.53	2.48	6.60	4.41	2.55	7.10	4.35	2.56
48.0	3.32	3.06	1.53	4.52	3.71	1.85	5.43	4.36	2.53	5.78	4.42	2.60	6.44	4.33	2.67	6.93	4.27	2.68

◆ Heating

Outdoor Air Temp.	Indoor Air Temperature : °CDB														
	16.0			18.0			20.0			22.0			24.0		
°CWB	TC	SHC	PI	TC	SHC	PI	TC	SHC	PI	TC	SHC	PI	TC	SHC	PI
-20.0	4.43		1.76	4.39		1.88	4.35		2.01	4.32		2.14	4.28		2.28
-15.0	5.48		2.01	5.44		2.13	5.40		2.26	5.37		2.39	5.33		2.52
-10.0	6.53		2.26	6.49		2.39	6.45		2.51	6.42		2.64	6.38		2.76
-5.0	7.58		2.51	7.54		2.64	7.50		2.76	7.20		2.64	6.90		2.52
0.0	8.30		2.76	7.90		2.64	7.50		2.51	7.20		2.40	6.90		2.28
6.0	8.30		2.43	7.90		2.32	7.50		2.21	7.20		2.10	6.90		1.99
10.0	8.30		2.26	7.90		2.13	7.50		2.01	7.20		1.90	6.90		1.80
15.0	8.30		2.01	7.90		1.88	7.50		1.76	7.20		1.66	6.90		1.55
18.0	8.30		1.86	7.90		1.73	7.50		1.61	7.20		1.51	6.90		1.41

Note

1. DB : Dry bulb temperature(°C), WB : Wet bulb temperature(°C)
2. TC : Total capacity(kW), SHC : Sensible Heating Capacity(kW)
3. PI : Power Input (kW, Compressor + indoor fan motor + outdoor fan motor)
4. All capacities are net. A deduction (cooling mode) or an addition (heating mode) of Capacity due to operating heat of indoor unit motor is reflected.
5. Direct interpolation is permissible. Do not extrapolate.
6. Rated capacities and power inputs are based on standard temperature and piping conditions, and it can be found on specifications table. Except for rated value, the performance is not guaranteed.
7. In accordance with the test standard(or nations), the rating will vary slightly.

■ Correction factor due to the indoor unit combination

◆ Cooling

Compact										
Indoor Unit	ZTNW24GBLA1 [CT24F NB0]		ZBNW24GM1A2 [CM24F N11]		ZBNW24GMAA0 [CM24F NA0]		ZBNW24GL3A1 [CL24F N30]		ZVNW24GM1A1 [UV24F N10]	
	TC	PI	TC	PI	TC	PI	TC	PI	TC	PI
Max.	1.10	1.20	1.10	1.40	1.10	1.40	1.10	1.27	1.10	1.24
Rated	1.00	1.00	1.00	1.17	1.00	1.17	1.00	1.06	1.00	1.03

◆ Heating

Compact										
Indoor Unit	ZTNW24GBLA1 [CT24F NB0]		ZBNW24GM1A2 [CM24F N11]		ZBNW24GMAA0 [CM24F NA0]		ZBNW24GL3A1 [CL24F N30]		ZVNW24GM1A1 [UV24F N10]	
	TC	PI	TC	PI	TC	PI	TC	PI	TC	PI
Max.	1.15	1.30	1.13	1.28	1.09	1.28	1.15	1.42	1.12	1.31
Rated	1.00	1.00	0.99	0.98	0.99	0.98	1.00	1.09	0.97	1.01

Note

Except for standard temperature condition, the capacity is not guaranteed.

6. Capacity Tables

■ Combined with 30k indoor units

◆ Cooling

Outdoor Air Temp.	Indoor Air Temperature : °CDB / °CWB																	
	20.0 / 14.0			22.0 / 16.0			25.0 / 18.0			27.0 / 19.0			30.0 / 22.0			32.0 / 24.0		
°CDB	TC	SHC	PI	TC	SHC	PI	TC	SHC	PI	TC	SHC	PI	TC	SHC	PI	TC	SHC	PI
20.0	5.26	4.11	1.10	6.58	4.83	1.45	7.59	5.55	1.81	8.36	5.91	1.88	9.12	5.81	1.95	9.71	5.74	1.96
25.0	4.97	3.98	1.21	6.30	4.71	1.58	7.31	5.43	1.95	8.07	5.79	2.02	8.84	5.69	2.09	9.42	5.62	2.11
32.0	4.57	3.81	1.38	5.90	4.54	1.74	6.91	5.26	2.15	7.67	5.62	2.22	8.44	5.52	2.29	9.02	5.45	2.31
35.0	4.40	3.74	1.45	5.73	4.46	1.82	6.73	5.19	2.24	7.50	5.55	2.31	8.27	5.45	2.38	8.85	5.38	2.39
40.0	4.12	3.62	1.57	5.44	4.34	1.94	6.45	5.07	2.49	6.98	5.25	2.56	7.72	5.15	2.63	8.28	5.08	2.65
43.0	3.95	3.55	1.64	5.27	4.27	2.01	6.28	4.99	2.63	6.67	5.07	2.71	7.39	4.97	2.78	7.94	4.91	2.80
46.0	3.77	3.47	1.71	5.10	4.20	2.08	6.11	4.92	2.78	6.36	4.89	2.86	7.07	4.79	2.93	7.60	4.73	2.95
48.0	3.66	3.42	1.76	4.98	4.15	2.13	5.99	4.87	2.88	6.15	4.76	2.96	6.85	4.67	3.03	7.38	4.61	3.05

◆ Heating

Outdoor Air Temp.	Indoor Air Temperature : °CDB									
	16.0		18.0		20.0		22.0		24.0	
°CWB	TC	PI	TC	PI	TC	PI	TC	PI	TC	PI
-20.0	4.54	1.89	4.50	2.02	4.46	2.15	4.43	2.30	4.39	2.44
-15.0	5.69	2.15	5.65	2.29	5.61	2.42	5.57	2.56	5.54	2.70
-10.0	6.84	2.42	6.79	2.56	6.75	2.69	6.72	2.83	6.68	2.96
-5.0	7.98	2.69	7.94	2.83	7.90	2.96	7.88	2.83	7.84	2.70
0.0	8.75	2.96	8.32	2.83	7.90	2.69	7.58	2.57	7.27	2.44
6.0	8.75	2.61	8.32	2.49	7.90	2.37	7.58	2.25	7.27	2.13
10.0	8.75	2.42	8.32	2.29	7.90	2.15	7.58	2.04	7.27	1.93
15.0	8.75	2.15	8.32	2.02	7.90	1.89	7.58	1.78	7.27	1.67
18.0	8.75	1.99	8.32	1.86	7.90	1.72	7.58	1.62	7.27	1.51

Note

1. DB : Dry bulb temperature(°C), WB : Wet bulb temperature(°C)
2. TC : Total capacity(kW), SHC : Sensible Heating Capacity(kW)
3. PI : Power Input (kW, Compressor + indoor fan motor + outdoor fan motor)
4. All capacities are net. A deduction (cooling mode) or an addition (heating mode) of Capacity due to operating heat of indoor unit motor is reflected.
5. Direct interpolation is permissible. Do not extrapolate.
6. Rated capacities and power inputs are based on standard temperature and piping conditions, and it can be found on specifications table. Except for rated value, the performance is not guaranteed.
7. In accordance with the test standard(or nations), the rating will vary slightly.

■ Correction factor due to the indoor unit combination

◆ Cooling

Compact										
Indoor Unit	ZTNW30GBLA1 [UT30F NB0]		ZBNW30GM1A2 [UM30F N11]		ZBNW30GMAA0 [UM30F NA0]		ZVNW30GM1A1 [UV30F N10]		ZJNW30GRLA1 [US30F NR0]	
	TC	PI	TC	PI	TC	PI	TC	PI	TC	PI
Max.	1.10	1.20	1.10	1.34	1.11	1.33	1.10	1.26	1.10	1.20
Rated	1.00	1.00	1.00	1.11	1.00	1.11	1.00	1.05	1.00	1.00

◆ Heating

Compact										
Indoor Unit	ZTNW30GBLA1 [UT30F NB0]		ZBNW30GM1A2 [UM30F N11]		ZBNW30GMAA0 [UM30F NA0]		ZVNW30GM1A1 [UV30F N10]		ZJNW30GRLA1 [US30F NR0]	
	TC	PI	TC	PI	TC	PI	TC	PI	TC	PI
Max.	1.10	1.30	1.11	1.23	1.11	1.24	1.11	1.36	1.07	1.17
Rated	1.00	1.00	1.01	0.95	1.01	0.95	1.01	1.05	0.97	0.90

Note

Except for standard temperature condition, the capacity is not guaranteed.

6. Capacity Tables

6.3 ZUUW30GA1 [UUC1 U40]

Combined with 24k indoor units

Cooling

Outdoor Air Temp.	Indoor Air Temperature : °CDB / °CWB																	
	20.0 / 14.0			22.0 / 16.0			25.0 / 18.0			27.0 / 19.0			30.0 / 22.0			32.0 / 24.0		
°CDB	TC	SHC	PI	TC	SHC	PI	TC	SHC	PI	TC	SHC	PI	TC	SHC	PI	TC	SHC	PI
20.0	4.77	3.77	0.79	5.97	4.44	1.04	6.88	5.10	1.30	7.58	5.44	1.35	8.27	5.34	1.40	8.80	5.28	1.41
25.0	4.51	3.66	0.87	5.71	4.33	1.13	6.62	4.99	1.40	7.32	5.32	1.45	8.01	5.23	1.50	8.54	5.16	1.51
32.0	4.15	3.50	0.99	5.35	4.17	1.25	6.26	4.83	1.55	6.96	5.17	1.60	7.65	5.07	1.65	8.18	5.01	1.66
35.0	3.99	3.44	1.04	5.19	4.10	1.31	6.11	4.77	1.61	6.80	5.10	1.66	7.49	5.00	1.71	8.02	4.94	1.72
40.0	3.73	3.33	1.13	4.93	3.99	1.39	5.85	4.66	1.71	6.54	4.99	1.76	7.24	4.89	1.81	7.76	4.83	1.82
43.0	3.58	3.26	1.18	4.78	3.92	1.45	5.69	4.59	1.78	6.39	4.92	1.83	7.08	4.83	1.88	7.61	4.76	1.89
46.0	3.42	3.19	1.23	4.62	3.86	1.50	5.54	4.52	1.84	6.43	5.01	1.89	7.15	4.91	1.94	7.69	4.85	1.95
48.0	3.32	3.15	1.27	4.52	3.81	1.53	5.43	4.48	2.02	6.46	5.07	2.08	7.19	4.97	2.13	7.75	4.90	2.14

Heating

Outdoor Air Temp.	Indoor Air Temperature : °CDB									
	16.0		18.0		20.0		22.0		24.0	
°CWB	TC	PI	TC	PI	TC	PI	TC	PI	TC	PI
-20.0	5.62	1.36	5.58	1.47	5.53	1.58	5.49	1.71	5.45	1.83
-15.0	6.41	1.58	6.37	1.69	6.32	1.80	6.28	1.92	6.24	2.04
-10.0	7.20	1.80	7.16	1.92	7.11	2.03	7.07	2.14	7.03	2.25
-5.0	7.99	2.03	7.95	2.14	7.90	2.25	7.58	2.15	7.27	2.04
0.0	8.75	2.25	8.32	2.14	7.90	2.03	7.58	1.93	7.27	1.83
6.0	8.75	1.94	8.32	1.85	7.90	1.76	7.58	1.67	7.27	1.58
10.0	8.75	1.80	8.32	1.69	7.90	1.58	7.58	1.50	7.27	1.42
15.0	8.75	1.58	8.32	1.47	7.90	1.36	7.58	1.28	7.27	1.21
18.0	8.75	1.45	8.32	1.33	7.90	1.22	7.58	1.15	7.27	1.08

Note

1. DB : Dry bulb temperature(°C), WB : Wet bulb temperature(°C)
2. TC : Total capacity(kW), SHC : Sensible Heating Capacity(kW)
3. PI : Power Input (kW, Compressor + indoor fan motor + outdoor fan motor)
4. All capacities are net. A deduction (cooling mode) or an addition (heating mode) of Capacity due to operating heat of indoor unit motor is reflected.
5. Direct interpolation is permissible. Do not extrapolate.
6. Rated capacities and power inputs are based on standard temperature and piping conditions, and it can be found on specifications table. Except for rated value, the performance is not guaranteed.
7. In accordance with the test standard(or nations), the rating will vary slightly.

Correction factor due to the indoor unit combination

Cooling

H-Inverter						
Indoor Unit	Z1NW24GALH1 [UT24FH NA0]		ZBNW24GM2H1 [UM24FH N20]		ZVNW24GM2H1 [UV24FH N20]	
	TC	PI	TC	PI	TC	PI
Max.	1.22	1.39	1.22	1.54	1.22	1.51
Rated	1.00	1.00	1.00	1.11	1.00	1.08

Standard												
Indoor Unit	Z1NW24GBLA1 [CT24F NB0]		ZBNW24GM1A2 [CM24F N11]		ZBNW24GMAA0 [CM24F NA0]		ZVNW24GM1A1 [UV24F N10]		ZBNW24GL3A1 [CL24F N30]		ZMNW24GSKC0 [MJ24PC NSK]	
	TC	PI	TC	PI	TC	PI	TC	PI	TC	PI	TC	PI
Max.	1.17	1.60	1.17	1.62	0.94	1.16	1.17	1.62	1.15	1.71	1.13	1.55
Rated	1.00	1.16	1.00	1.17	1.00	1.17	0.99	1.20	1.00	1.22	1.00	1.20

Heating

H-Inverter						
Indoor Unit	Z1NW24GALH1 [UT24FH NA0]		ZBNW24GM2H1 [UM24FH N20]		ZVNW24GM2H1 [UV24FH N20]	
	TC	PI	TC	PI	TC	PI
Max.	1.25	1.44	1.19	1.43	1.19	1.49
Rated	1.00	1.00	0.95	0.99	0.95	1.03

Standard												
Indoor Unit	Z1NW24GBLA1 [CT24F NB0]		ZBNW24GM1A2 [CM24F N11]		ZBNW24GMAA0 [CM24F NA0]		ZVNW24GM1A1 [UV24F N10]		ZBNW24GL3A1 [CL24F N30]		ZMNW24GSKC0 [MJ24PC NSK]	
	TC	PI	TC	PI	TC	PI	TC	PI	TC	PI	TC	PI
Max.	1.14	1.61	1.14	1.87	0.86	1.30	1.14	1.75	1.14	1.88	0.92	1.42
Rated	0.95	1.11	0.95	1.29	0.95	1.29	0.95	1.25	0.95	1.21	0.95	1.42

Note

Except for standard temperature condition, the capacity is not guaranteed.

6. Capacity Tables

Combined with 30k indoor units

Cooling

Outdoor Air Temp.	Indoor Air Temperature : °CDB / °CWB																	
	20.0 / 14.0			22.0 / 16.0			25.0 / 18.0			27.0 / 19.0			30.0 / 22.0			32.0 / 24.0		
°CDB	TC	SHC	PI	TC	SHC	PI	TC	SHC	PI	TC	SHC	PI	TC	SHC	PI	TC	SHC	PI
20.0	5.61	4.38	1.01	7.02	5.15	1.34	8.10	5.92	1.66	8.92	6.31	1.73	9.73	6.20	1.80	10.35	6.12	1.81
25.0	5.31	4.25	1.11	6.72	5.02	1.45	7.79	5.79	1.80	8.61	6.18	1.86	9.43	6.07	1.92	10.05	5.99	1.94
32.0	4.88	4.07	1.26	6.29	4.84	1.61	7.37	5.61	1.98	8.18	6.00	2.05	9.00	5.89	2.11	9.62	5.81	2.13
35.0	4.70	3.99	1.34	6.11	4.76	1.67	7.18	5.53	2.06	8.00	5.92	2.12	8.82	5.81	2.19	9.44	5.73	2.21
40.0	4.39	3.86	1.44	5.80	4.63	1.79	6.88	5.40	2.20	7.69	5.79	2.26	8.51	5.68	2.32	9.13	5.61	2.34
43.0	4.21	3.78	1.51	5.62	4.55	1.85	6.70	5.33	2.28	7.57	5.76	2.34	8.39	5.64	2.40	9.02	5.57	2.41
46.0	4.03	3.70	1.58	5.44	4.48	1.92	6.51	5.25	2.50	7.44	5.72	2.57	8.27	5.61	2.63	8.90	5.53	2.65
48.0	3.90	3.65	1.62	5.32	4.42	1.97	6.39	5.20	2.65	7.36	5.70	2.72	8.19	5.59	2.79	8.83	5.51	2.80

Heating

Outdoor Air Temp.	Indoor Air Temperature : °CDB											
	16.0		18.0		20.0		22.0		24.0			
°CWB	TC	PI	TC	PI	TC	PI	TC	PI	TC	PI		
-20.0	5.72	1.70	5.67	1.82	5.63	1.95	5.58	2.08	5.54	2.21		
-15.0	6.85	1.95	6.80	2.07	6.75	2.19	6.71	2.31	6.66	2.44		
-10.0	7.97	2.19	7.92	2.31	7.88	2.43	7.83	2.55	7.79	2.68		
-5.0	9.10	2.43	9.05	2.55	9.00	2.68	8.64	2.56	8.28	2.44		
0.0	9.96	2.68	9.48	2.55	9.00	2.43	8.64	2.32	8.28	2.21		
6.0	9.96	2.35	9.48	2.25	9.00	2.14	8.64	2.03	8.28	1.93		
10.0	9.96	2.19	9.48	2.07	9.00	1.95	8.64	1.84	8.28	1.74		
15.0	9.96	1.95	9.48	1.82	9.00	1.70	8.64	1.60	8.28	1.51		
18.0	9.96	1.80	9.48	1.68	9.00	1.56	8.64	1.46	8.28	1.36		

Note

1. DB : Dry bulb temperature(°C), WB : Wet bulb temperature(°C)
2. TC : Total capacity(kW), SHC : Sensible Heating Capacity(kW)
3. PI : Power Input (kW, Compressor + indoor fan motor + outdoor fan motor)
4. All capacities are net. A deduction (cooling mode) or an addition (heating mode) of Capacity due to operating heat of indoor unit motor is reflected.
5. Direct interpolation is permissible. Do not extrapolate.
6. Rated capacities and power inputs are based on standard temperature and piping conditions, and it can be found on specifications table. Except for rated value, the performance is not guaranteed.
7. In accordance with the test standard(or nations), the rating will vary slightly.

Correction factor due to the indoor unit combination

Cooling

H-Inverter						
Indoor Unit	ZTNW30GALH1 [UT30FH NA0]		ZBNW30GM2H1 [UM30FH N20]		ZVNW30GM2H1 [UV30FH N20]	
	TC	PI	TC	PI	TC	PI
Max.	1.19	1.33	1.16	1.41	1.19	1.47
Rated	1.00	1.00	0.98	1.06	1.00	1.11

Standard										
Indoor Unit	ZTNW30GBLA1 [UT30F NB0]		ZBNW30GM1A2 [UM30F N11]		ZBNW30GMAA0 [UM30F NA0]		ZVNW30GM1A1 [UV30F N10]		ZJNW30GRLA1 [US30F NR0]	
	TC	PI	TC	PI	TC	PI	TC	PI	TC	PI
Max.	1.15	1.48	1.12	1.43	0.95	1.07	1.10	1.45	1.13	1.49
Rated	1.00	1.16	0.98	1.05	0.94	1.01	0.96	1.06	1.00	1.08

Heating

H-Inverter						
Indoor Unit	ZTNW30GALH1 [UT30FH NA0]		ZBNW30GM2H1 [UM30FH N20]		ZVNW30GM2H1 [UV30FH N20]	
	TC	PI	TC	PI	TC	PI
Max.	1.19	1.37	1.19	1.45	1.18	1.53
Rated	1.00	1.00	1.00	1.06	0.99	1.12

Standard										
Indoor Unit	ZTNW30GBLA1 [UT30F NB0]		ZBNW30GM1A2 [UM30F N11]		ZBNW30GMAA0 [UM30F NA0]		ZVNW30GM1A1 [UV30F N10]		ZJNW30GRLA1 [US30F NR0]	
	TC	PI	TC	PI	TC	PI	TC	PI	TC	PI
Max.	1.12	1.52	1.12	1.55	0.93	1.14	1.07	1.50	1.11	1.50
Rated	0.99	1.22	1.00	1.23	1.00	1.13	0.96	1.17	1.00	1.17

Note

Except for standard temperature condition, the capacity is not guaranteed.

6. Capacity Tables

■ Combined with 36k indoor units

◆ Cooling

Outdoor Air Temp.	Indoor Air Temperature : °CDB / °CWB																	
	20.0 / 14.0			22.0 / 16.0			25.0 / 18.0			27.0 / 19.0			30.0 / 22.0			32.0 / 24.0		
°CDB	TC	SHC	PI	TC	SHC	PI	TC	SHC	PI	TC	SHC	PI	TC	SHC	PI	TC	SHC	PI
20.0	6.66	5.76	1.33	8.34	6.78	1.76	9.62	7.79	2.18	10.59	8.30	2.27	11.56	8.16	2.35	12.29	8.06	2.37
25.0	6.30	5.59	1.46	7.98	6.61	1.90	9.25	7.62	2.36	10.22	8.13	2.44	11.19	7.99	2.53	11.93	7.89	2.54
32.0	5.79	5.35	1.66	7.47	6.37	2.11	8.75	7.38	2.60	9.72	7.89	2.69	10.69	7.75	2.77	11.42	7.65	2.79
35.0	5.58	5.25	1.75	7.25	6.27	2.20	8.53	7.28	2.71	9.50	7.79	2.79	10.47	7.64	2.87	11.21	7.55	2.89
40.0	5.21	5.08	1.90	6.89	6.10	2.34	8.17	7.11	2.85	8.84	7.37	2.93	9.78	7.23	3.01	10.49	7.13	3.03
43.0	5.00	4.98	1.98	6.67	5.99	2.43	7.95	7.01	2.93	8.45	7.12	3.01	9.36	6.98	3.10	10.06	6.89	3.11
46.0	4.78	4.73	2.07	6.46	5.89	2.52	7.73	6.91	3.01	8.05	6.86	3.10	8.95	6.72	3.18	9.63	6.63	3.20
48.0	4.63	4.59	2.13	6.31	5.82	2.58	7.59	6.84	3.07	7.79	6.69	3.15	8.67	6.55	3.23	9.34	6.46	3.25

◆ Heating

Outdoor Air Temp.	Indoor Air Temperature : °CDB														
	16.0			18.0			20.0			22.0			24.0		
°CWB	TC	SHC	PI	TC	SHC	PI	TC	SHC	PI	TC	SHC	PI	TC	SHC	PI
-20.0	6.21		2.20	6.16		2.36	6.10		2.52	6.05		2.69	6.00		2.86
-15.0	7.78		2.52	7.72		2.68	7.67		2.83	7.62		3.00	7.57		3.16
-10.0	9.34		2.83	9.29		2.99	9.23		3.15	9.18		3.31	9.14		3.46
-5.0	10.91		3.15	10.86		3.31	10.80		3.46	10.37		3.31	9.94		3.16
0.0	11.96		3.46	11.38		3.31	10.80		3.15	10.37		3.00	9.94		2.86
6.0	11.96		3.05	11.38		2.91	10.80		2.77	10.37		2.63	9.94		2.49
10.0	11.96		2.83	11.38		2.68	10.80		2.52	10.37		2.38	9.94		2.25
15.0	11.96		2.52	11.38		2.36	10.80		2.20	10.37		2.08	9.94		1.95
18.0	11.96		2.33	11.38		2.17	10.80		2.01	10.37		1.89	9.94		1.77

Note

1. DB : Dry bulb temperature(°C), WB : Wet bulb temperature(°C)
2. TC : Total capacity(kW), SHC : Sensible Heating Capacity(kW)
3. PI : Power Input (kW, Compressor + indoor fan motor + outdoor fan motor)
4. All capacities are net. A deduction (cooling mode) or an addition (heating mode) of Capacity due to operating heat of indoor unit motor is reflected.
5. Direct interpolation is permissible. Do not extrapolate.
6. Rated capacities and power inputs are based on standard temperature and piping conditions, and it can be found on specifications table. Except for rated value, the performance is not guaranteed.
7. In accordance with the test standard(or nations), the rating will vary slightly.

■ Correction factor due to the indoor unit combination

◆ Cooling

Compact												
Indoor Unit	ZTNW36GALA1 [UT36F NAO]			ZBNW36GM2A2 [UM36F N21]			ZVNW36GM2A1 [UV36F N20]			ZJNW36GRLA1 [US36F NR0]		
	TC	SHC	PI	TC	SHC	PI	TC	SHC	PI	TC	SHC	PI
Max.	1.14		1.28	1.10		1.38	1.10		1.39	1.11		1.32
Rated	1.00		1.00	1.00		1.13	1.00		1.18	1.00		1.10

◆ Heating

Compact												
Indoor Unit	ZTNW36GALA1 [UT36F NAO]			ZBNW36GM2A2 [UM36F N21]			ZVNW36GM2A1 [UV36F N20]			ZJNW36GRLA1 [US36F NR0]		
	TC	SHC	PI	TC	SHC	PI	TC	SHC	PI	TC	SHC	PI
Max.	1.08		1.19	1.06		1.26	1.07		1.24	1.06		1.34
Rated	1.00		1.00	1.00		1.09	0.95		1.00	1.00		1.08

Note

Except for standard temperature condition, the capacity is not guaranteed.

6. Capacity Tables

6.4 ZUUW48GA1 [UUD1 U30] / ZUUW48LA1 [UUD3 U30]

Combined with 36k indoor units

Cooling

Outdoor Air Temp.	Indoor Air Temperature : °CDB / °CWB																	
	20.0 / 14.0			22.0 / 16.0			25.0 / 18.0			27.0 / 19.0			30.0 / 22.0			32.0 / 24.0		
°CDB	TC	SHC	PI	TC	SHC	PI	TC	SHC	PI	TC	SHC	PI	TC	SHC	PI	TC	SHC	PI
20.0	6.66	5.62	1.02	8.34	6.61	1.35	9.62	7.60	1.68	10.59	8.10	1.75	11.56	7.96	1.81	12.29	7.86	1.83
25.0	6.30	5.46	1.12	7.98	6.45	1.47	9.25	7.44	1.82	10.22	7.93	1.88	11.19	7.79	1.95	11.93	7.70	1.96
32.0	5.79	5.22	1.28	7.47	6.21	1.62	8.75	7.20	2.00	9.72	7.70	2.07	10.69	7.56	2.13	11.42	7.46	2.15
35.0	5.58	5.12	1.35	7.25	6.11	1.69	8.53	7.10	2.09	9.50	7.60	2.15	10.47	7.46	2.21	11.21	7.36	2.23
40.0	5.21	4.96	1.46	6.89	5.95	1.80	8.17	6.94	2.22	9.14	7.43	2.28	10.11	7.29	2.35	10.85	7.20	2.36
43.0	5.00	4.86	1.53	6.67	5.85	1.87	7.95	6.84	2.30	8.92	7.33	2.36	9.89	7.19	2.43	10.63	7.10	2.44
46.0	4.78	4.76	1.60	6.46	5.75	1.94	7.73	6.74	2.38	8.98	7.47	2.44	9.98	7.32	2.51	10.75	7.22	2.52
48.0	4.63	4.59	1.64	6.31	5.68	1.99	7.59	6.67	2.62	9.03	7.56	2.69	10.05	7.41	2.76	10.83	7.31	2.77

Heating

Outdoor Air Temp.	Indoor Air Temperature : °CDB									
	16.0		18.0		20.0		22.0		24.0	
°CWB	TC	PI	TC	PI	TC	PI	TC	PI	TC	PI
-20.0	7.68	1.91	7.62	2.05	7.56	2.18	7.50	2.33	7.45	2.48
-15.0	8.76	2.18	8.70	2.32	8.64	2.45	8.58	2.60	8.53	2.74
-10.0	9.84	2.45	9.78	2.59	9.72	2.73	9.66	2.86	9.61	3.00
-5.0	10.92	2.73	10.86	2.86	10.80	3.00	10.37	2.87	9.94	2.74
0.0	11.96	3.00	11.38	2.86	10.80	2.73	10.37	2.60	9.94	2.48
6.0	11.96	2.64	11.38	2.52	10.80	2.40	10.37	2.28	9.94	2.16
10.0	11.96	2.45	11.38	2.32	10.80	2.18	10.37	2.07	9.94	1.95
15.0	11.96	2.18	11.38	2.05	10.80	1.91	10.37	1.80	9.94	1.69
18.0	11.96	2.02	11.38	1.88	10.80	1.75	10.37	1.64	9.94	1.53

Note

1. DB : Dry bulb temperature(°C), WB : Wet bulb temperature(°C)
2. TC : Total capacity(kW), SHC : Sensible Heating Capacity(kW)
3. PI : Power Input (kW, Compressor + indoor fan motor + outdoor fan motor)
4. All capacities are net. A deduction (cooling mode) or an addition (heating mode) of Capacity due to operating heat of indoor unit motor is reflected.
5. Direct interpolation is permissible. Do not extrapolate.
6. Rated capacities and power inputs are based on standard temperature and piping conditions, and it can be found on specifications table. Except for rated value, the performance is not guaranteed.
7. In accordance with the test standard(or nations), the rating will vary slightly.

Correction factor due to the indoor unit combination

Cooling

H-Inverter							
Indoor Unit	ZTNW36GALH1 [UT36FH NA0]		ZBNW36GM3H1 [UM36FH N30]		ZVNW36GM2H1 [UV36FH N20]		
	TC	PI	TC	PI	TC	PI	
Max.	1.35	1.50	1.35	1.58	1.35	1.74	
Rated	1.00	1.00	1.00	1.05	1.00	1.16	

Standard										
Indoor Unit	ZTNW36GALA1 [UT36F NA0]		ZBNW36GM2A2 [UM36F N21]		ZVNW36GM2A1 [UV36F N20]		ZJNW36GRLA1 [US36F NR0]		ZTNW36GYLA0 [UT36F NY0]	
	TC	PI	TC	PI	TC	PI	TC	PI	TC	PI
Max.	1.32	1.60	1.32	1.77	1.32	1.87	1.32	1.82	1.32	1.85
Rated	1.00	1.05	1.00	1.16	1.00	1.23	1.00	1.20	1.16	1.42

Heating

H-Inverter							
Indoor Unit	ZTNW36GALH1 [UT36FH NA0]		ZBNW36GM3H1 [UM36FH N30]		ZVNW36GM2H1 [UV36FH N20]		
	TC	PI	TC	PI	TC	PI	
Max.	1.27	1.40	1.27	1.50	1.27	1.48	
Rated	1.00	1.00	1.00	1.07	1.00	1.06	

Standard										
Indoor Unit	ZTNW36GALA1 [UT36F NA0]		ZBNW36GM2A2 [UM36F N21]		ZVNW36GM2A1 [UV36F N20]		ZJNW36GRLA1 [US36F NR0]		ZTNW36GYLA0 [UT36F NY0]	
	TC	PI	TC	PI	TC	PI	TC	PI	TC	PI
Max.	1.24	1.38	1.24	1.57	1.24	1.47	1.24	1.57	1.24	1.77
Rated	1.00	1.01	1.00	1.15	1.00	1.08	1.00	1.15	1.13	1.30

Note

Except for standard temperature condition, the capacity is not guaranteed.

6. Capacity Tables

■ Combined with 42k indoor units

◆ Cooling

Outdoor Air Temp.	Indoor Air Temperature : °CDB / °CWB																	
	20.0 / 14.0			22.0 / 16.0			25.0 / 18.0			27.0 / 19.0			30.0 / 22.0			32.0 / 24.0		
°CDB	TC	SHC	PI	TC	SHC	PI	TC	SHC	PI	TC	SHC	PI	TC	SHC	PI	TC	SHC	PI
20.0	8.49	6.80	1.49	10.62	8.00	1.98	12.25	9.20	2.46	13.48	9.80	2.55	14.72	9.63	2.65	15.66	9.51	2.67
25.0	8.03	6.60	1.64	10.16	7.80	2.14	11.79	9.00	2.65	13.02	9.60	2.75	14.26	9.43	2.84	15.20	9.31	2.86
32.0	7.38	6.32	1.87	9.52	7.52	2.37	11.14	8.72	2.93	12.38	9.32	3.02	13.61	9.14	3.12	14.55	9.03	3.14
35.0	7.10	6.20	1.97	9.24	7.40	2.47	10.86	8.60	3.05	12.10	9.20	3.14	13.34	9.02	3.23	14.27	8.91	3.25
40.0	6.64	6.00	2.13	8.78	7.20	2.64	10.40	8.39	3.24	11.64	8.99	3.34	12.87	8.82	3.43	13.81	8.71	3.45
43.0	6.36	5.88	2.23	8.50	7.07	2.73	10.13	8.27	3.36	11.36	8.87	3.45	12.60	8.70	3.55	13.54	8.59	3.57
46.0	6.09	5.75	2.33	8.22	6.95	2.83	9.85	8.15	3.48	11.44	9.03	3.57	12.72	8.86	3.66	13.69	8.74	3.68
48.0	5.90	5.67	2.40	8.04	6.87	2.90	9.67	8.07	3.82	11.50	9.15	3.93	12.80	8.96	4.03	13.79	8.84	4.05

◆ Heating

Outdoor Air Temp.	Indoor Air Temperature : °CDB											
	16.0		18.0		20.0		22.0		24.0			
°CWB	TC	PI	TC	PI	TC	PI	TC	PI	TC	PI		
-20.0	9.61	2.62	9.53	2.80	9.45	2.99	9.38	3.19	9.31	3.39		
-15.0	10.96	2.99	10.88	3.18	10.80	3.36	10.73	3.56	10.66	3.75		
-10.0	12.31	3.36	12.23	3.55	12.15	3.74	12.08	3.93	12.01	4.11		
-5.0	13.66	3.74	13.58	3.93	13.50	4.11	12.96	3.93	12.42	3.75		
0.0	14.95	4.11	14.22	3.93	13.50	3.74	12.96	3.57	12.42	3.39		
6.0	14.95	3.62	14.22	3.46	13.50	3.29	12.96	3.13	12.42	2.96		
10.0	14.95	3.36	14.22	3.18	13.50	2.99	12.96	2.83	12.42	2.67		
15.0	14.95	2.99	14.22	2.80	13.50	2.62	12.96	2.47	12.42	2.31		
18.0	14.95	2.77	14.22	2.58	13.50	2.39	12.96	2.25	12.42	2.10		

Note

1. DB : Dry bulb temperature(°C), WB : Wet bulb temperature(°C)
2. TC : Total capacity(kW), SHC : Sensible Heating Capacity(kW)
3. PI : Power Input (kW, Compressor + indoor fan motor + outdoor fan motor)
4. All capacities are net. A deduction (cooling mode) or an addition (heating mode) of Capacity due to operating heat of indoor unit motor is reflected.
5. Direct interpolation is permissible. Do not extrapolate.
6. Rated capacities and power inputs are based on standard temperature and piping conditions, and it can be found on specifications table. Except for rated value, the performance is not guaranteed.
7. In accordance with the test standard(or nations), the rating will vary slightly.

■ Correction factor due to the indoor unit combination

◆ Cooling

H-Inverter							
Indoor Unit	ZTNW42GALH1 [UT42FH NA0]		ZBNW42GM3H1 [UM42FH N30]		ZVNW42GM2H1 [UV42FH N20]		
	TC	PI	TC	PI	TC	PI	
Max.	1.20	1.35	1.19	1.45	1.20	1.56	
Rated	1.00	1.00	0.99	1.08	1.00	1.16	

Standard							
Indoor Unit	ZTNW42GALA1 [UT42F NA0]		ZBNW42GM2A2 [UM42F N21]		ZVNW42GM2A1 [UV42F N20]		
	TC	PI	TC	PI	TC	PI	
Max.	1.17	1.37	1.16	1.44	1.17	1.61	
Rated	1.00	1.05	0.99	1.11	1.00	1.24	

◆ Heating

H-Inverter							
Indoor Unit	ZTNW42GALH1 [UT42FH NA0]		ZBNW42GM3H1 [UM42FH N30]		ZVNW42GM2H1 [UV42FH N20]		
	TC	PI	TC	PI	TC	PI	
Max.	1.20	1.30	1.20	1.39	1.20	1.48	
Rated	1.00	1.00	1.00	1.07	1.00	1.14	

Standard							
Indoor Unit	ZTNW42GALA1 [UT42F NA0]		ZBNW42GM2A2 [UM42F N21]		ZVNW42GM2A1 [UV42F N20]		
	TC	PI	TC	PI	TC	PI	
Max.	1.17	1.39	1.17	1.48	1.17	1.48	
Rated	1.00	1.07	1.00	1.14	1.00	1.14	

Note

Except for standard temperature condition, the capacity is not guaranteed.

6. Capacity Tables

■ Combined with 48k indoor units

◆ Cooling

Outdoor Air Temp.	Indoor Air Temperature : °CDB / °CWB																	
	20.0 / 14.0			22.0 / 16.0			25.0 / 18.0			27.0 / 19.0			30.0 / 22.0			32.0 / 24.0		
°CDB	TC	SHC	PI	TC	SHC	PI	TC	SHC	PI	TC	SHC	PI	TC	SHC	PI	TC	SHC	PI
20.0	9.40	7.24	1.82	11.77	8.51	2.41	13.56	9.79	3.00	14.93	10.42	3.11	16.30	10.24	3.23	17.34	10.12	3.25
25.0	8.89	7.02	2.00	11.25	8.30	2.61	13.05	9.57	3.24	14.42	10.21	3.35	15.79	10.03	3.47	16.83	9.90	3.49
32.0	8.17	6.72	2.28	10.54	8.00	2.89	12.34	9.27	3.57	13.71	9.91	3.69	15.07	9.73	3.80	16.12	9.60	3.82
35.0	7.87	6.59	2.40	10.23	7.87	3.01	12.03	9.14	3.71	13.40	9.78	3.83	14.77	9.60	3.95	15.81	9.48	3.97
40.0	7.36	6.38	2.60	9.72	7.65	3.21	11.52	8.93	3.95	12.89	9.57	4.07	14.08	9.27	4.18	15.11	9.15	4.21
43.0	7.05	6.25	2.72	9.42	7.53	3.34	11.21	8.80	4.18	12.43	9.32	4.30	13.67	9.07	4.41	14.69	8.95	4.44
46.0	6.74	6.12	2.84	9.11	7.40	3.46	10.91	8.67	4.40	11.97	9.08	4.52	13.25	8.87	4.64	14.26	8.75	4.66
48.0	6.54	6.04	2.92	8.90	7.31	3.54	10.70	8.59	4.55	11.66	8.91	4.67	12.98	8.73	4.79	13.98	8.61	4.82

◆ Heating

Outdoor Air Temp.	Indoor Air Temperature : °CDB											
	16.0		18.0		20.0		22.0		24.0			
°CWB	TC	PI	TC	PI	TC	PI	TC	PI	TC	PI		
-20.0	9.86	3.43	9.77	3.64	9.69	3.85	9.61	4.05	9.54	4.26		
-15.0	11.79	3.85	11.71	4.05	11.63	4.26	11.55	4.47	11.48	4.68		
-10.0	13.73	4.26	13.65	4.47	13.56	4.68	13.49	4.89	13.41	5.10		
-5.0	15.67	4.68	15.58	4.89	15.50	5.10	14.88	4.89	14.26	4.68		
0.0	17.16	5.10	16.33	4.89	15.50	4.68	14.88	4.47	14.26	4.26		
6.0	17.16	4.60	16.33	4.39	15.50	4.18	14.88	3.97	14.26	3.76		
10.0	17.16	4.26	16.33	4.05	15.50	3.85	14.88	3.64	14.26	3.43		
15.0	17.16	3.85	16.33	3.64	15.50	3.43	14.88	3.22	14.26	3.01		
18.0	17.16	3.59	16.33	3.39	15.50	3.18	14.88	2.97	14.26	2.76		

Note

1. DB : Dry bulb temperature(°C), WB : Wet bulb temperature(°C)
2. TC : Total capacity(kW), SHC : Sensible Heating Capacity(kW)
3. PI : Power Input (kW, Compressor + indoor fan motor + outdoor fan motor)
4. All capacities are net. A deduction (cooling mode) or an addition (heating mode) of Capacity due to operating heat of indoor unit motor is reflected.
5. Direct interpolation is permissible. Do not extrapolate.
6. Rated capacities and power inputs are based on standard temperature and piping conditions, and it can be found on specifications table. Except for rated value, the performance is not guaranteed.
7. In accordance with the test standard(or nations), the rating will vary slightly.

■ Correction factor due to the indoor unit combination

◆ Cooling

H-Inverter					
Indoor Unit	ZTNW48GALH1 [UT48FH NA0]			ZBNW48GM3H1 [UM48FH N30]	
	TC	PI	TC	PI	
Max.	1.20		1.35		1.45
Rated	1.00		1.00		1.08

Standard									
Indoor Unit	ZTNW48GALA1 [UT48F NA0]		ZBNW48GM3A2 [UM48F N31]		ZVNW48GM2A1 [UV48F N20]		ZTNW48GYLA0 [UT48F NY0]		
	TC	PI	TC	PI	TC	PI	TC	PI	
Max.	1.17	1.44	1.17	1.47	1.17	1.53	1.17	1.49	
Rated	1.00	1.11	1.00	1.13	1.00	1.17	1.00	1.15	

◆ Heating

H-Inverter					
Indoor Unit	ZTNW48GALH1 [UT48FH NA0]			ZBNW48GM3H1 [UM48FH N30]	
	TC	PI	TC	PI	
Max.	1.15		1.25		1.25
Rated	1.00		1.00		1.00

Standard									
Indoor Unit	ZTNW48GALA1 [UT48F NA0]		ZBNW48GM3A2 [UM48F N31]		ZVNW48GM2A1 [UV48F N20]		ZTNW48GYLA0 [UT48F NY0]		
	TC	PI	TC	PI	TC	PI	TC	PI	
Max.	1.13	1.28	1.13	1.26	1.13	1.39	1.13	1.33	
Rated	1.00	1.05	1.00	1.03	1.00	1.14	1.00	1.09	

Note

Except for standard temperature condition, the capacity is not guaranteed.

6. Capacity Tables

■ Combined with 60k indoor units

◆ Cooling

Outdoor Air Temp.	Indoor Air Temperature : °CDB / °CWB																	
	20.0 / 14.0			22.0 / 16.0			25.0 / 18.0			27.0 / 19.0			30.0 / 22.0			32.0 / 24.0		
°CDB	TC	SHC	PI	TC	SHC	PI	TC	SHC	PI	TC	SHC	PI	TC	SHC	PI	TC	SHC	PI
20.0	10.52	7.77	2.23	13.17	9.14	2.95	15.18	10.51	3.67	16.72	11.19	3.81	18.25	10.99	3.95	19.41	10.86	3.98
25.0	9.95	7.54	2.45	12.60	8.91	3.20	14.61	10.28	3.96	16.14	10.96	4.11	17.68	10.76	4.25	18.84	10.63	4.27
32.0	9.15	7.21	2.79	11.80	8.58	3.54	13.81	9.95	4.37	15.34	10.64	4.51	16.87	10.44	4.66	18.04	10.31	4.68
35.0	8.81	7.08	2.94	11.45	8.45	3.69	13.47	9.82	4.55	15.00	10.50	4.69	16.53	10.30	4.83	17.70	10.17	4.86
40.0	8.23	6.85	3.19	10.88	8.22	3.94	12.90	9.59	4.84	14.43	10.27	4.98	15.76	9.95	5.12	16.91	9.82	5.15
43.0	7.89	6.71	3.33	10.54	8.08	4.08	12.55	9.45	5.12	13.91	10.01	5.26	15.30	9.73	5.40	16.44	9.60	5.43
46.0	7.55	6.57	3.48	10.20	7.94	4.23	12.21	9.31	5.39	13.39	9.74	5.54	14.84	9.52	5.68	15.97	9.39	5.71
48.0	7.32	6.48	3.58	9.97	7.85	4.33	11.98	9.22	5.57	13.05	9.56	5.72	14.53	9.37	5.87	15.65	9.25	5.90

◆ Heating

Outdoor Air Temp.	Indoor Air Temperature : °CDB											
	16.0		18.0		20.0		22.0		24.0			
°CWB	TC	PI	TC	PI	TC	PI	TC	PI	TC	PI		
-20.0	11.13	4.41	11.03	4.68	10.94	4.95	10.85	5.22	10.77	5.49		
-15.0	13.31	4.95	13.22	5.22	13.13	5.49	13.04	5.76	12.96	6.03		
-10.0	15.50	5.49	15.41	5.76	15.31	6.03	15.23	6.29	15.14	6.56		
-5.0	17.69	6.03	17.59	6.29	17.50	6.56	16.80	6.29	16.10	6.03		
0.0	19.37	6.56	18.44	6.29	17.50	6.03	16.80	5.76	16.10	5.49		
6.0	19.37	5.92	18.44	5.65	17.50	5.38	16.80	5.11	16.10	4.84		
10.0	19.37	5.49	18.44	5.22	17.50	4.95	16.80	4.68	16.10	4.41		
15.0	19.37	4.95	18.44	4.68	17.50	4.41	16.80	4.14	16.10	3.87		
18.0	19.37	4.63	18.44	4.36	17.50	4.09	16.80	3.82	16.10	3.55		

Note

1. DB : Dry bulb temperature(°C), WB : Wet bulb temperature(°C)
2. TC : Total capacity(kW), SHC : Sensible Heating Capacity(kW)
3. PI : Power Input (kW, Compressor + indoor fan motor + outdoor fan motor)
4. All capacities are net. A deduction (cooling mode) or an addition (heating mode) of Capacity due to operating heat of indoor unit motor is reflected.
5. Direct interpolation is permissible. Do not extrapolate.
6. Rated capacities and power inputs are based on standard temperature and piping conditions, and it can be found on specifications table. Except for rated value, the performance is not guaranteed.
7. In accordance with the test standard(or nations), the rating will vary slightly.

■ Correction factor due to the indoor unit combination

◆ Cooling

H-Inverter		ZTNW60GALH1 [UT60FH NA0]	
Indoor Unit	TC	PI	
Max.	1.08	1.12	
Rated	1.00	1.00	

Standard		ZTNW60GALA1 [UT60F NA0]		ZBNW60GM3A2 [UM60F N31]		ZVNW60GM2A1 [UV60F N20]	
Indoor Unit	TC	PI	TC	PI	TC	PI	
Max.	1.05	1.24	1.05	1.18	1.04	1.27	
Rated	0.97	1.11	0.97	1.06	0.96	1.14	

◆ Heating

H-Inverter		ZTNW60GALH1 [UT60FH NA0]	
Indoor Unit	TC	PI	
Max.	1.10	1.15	
Rated	1.00	1.00	

Standard		ZTNW60GALA1 [UT60F NA0]		ZBNW60GM3A2 [UM60F N31]		ZVNW60GM2A1 [UV60F N20]	
Indoor Unit	TC	PI	TC	PI	TC	PI	
Max.	1.04	1.09	1.04	0.98	1.04	1.20	
Rated	0.97	0.95	0.96	0.86	0.96	1.04	

Note

Except for standard temperature condition, the capacity is not guaranteed.

6. Capacity Tables

◆ Synchro Equivalent Capacity Table(Cooling)

Max Power input is tabulated below

(Duo)

Model	CT18F * 2	CM18F * 2	CT24F * 2	CM24F * 2	UT30F * 2	UM30F * 2
PI	4.20	4.20	5.85	5.85	6.15	6.15

(Trio)

Model	CT12F * 3	CL12F * 3	CT18F * 3	CM18F * 3
PI	4.30	4.30	6.02	6.02

(Quartet)

Model	CT12F * 4	CL12F * 4
PI	5.94	5.94

◆ Synchro Equivalent Capacity Table(Heating)

Max Power input is tabulated below

(Duo)

Model	CT18F * 2	CM18F * 2	CT24F * 2	CM24F * 2	UT30F * 2	UM30F * 2
PI	3.80	3.80	5.92	5.92	6.48	6.48

(Trio)

Model	CT12F * 3	CL12F * 3	CT18F * 3	CM18F * 3
PI	4.00	4.00	6.27	6.27

(Quartet)

Model	CT12F * 4	CL12F * 4
PI	6.01	6.01

Note

1. DB : Dry bulb temperature(℃), WB : Wet bulb temperature(℃)
2. TC : Total capacity(kW), SHC : Sensible Heating Capacity(kW)
3. PI : Power Input (kW, Compressor + indoor fan motor + outdoor fan motor)
4. All capacities are net. A deduction (cooling mode) or an addition (heating mode) of Capacity due to operating heat of indoor unit motor is reflected.
5. For Synchro model operating simultaneously with combinations, The individual capacities of indoor unit are not given because they are same with the Single model capacities.
6. Direct interpolation is permissible. Do not extrapolate.
7. Rated capacities and power inputs are based on standard temperature and piping conditions, and it can be found on specifications table. Except for rated value, the performance is not guaranteed.
8. In accordance with the test standard(or nations), the rating will vary slightly.

7. Capacity Correction Factor

7.1 Rate of change in capacity due to the main piping length

■ 1 Phase Inverter

◆ Rate of change in cooling capacity

Piping length (m)		IDU Grade	Capacity (kW)	5	10	15	20	30	35	40	50	60	70	75	80	85	
Rate of change in capacity(%)	ZUUW12GA1 [UUA1 U0]	H-Inverter Standard	2.5 / 3.5	100.0	100.0	100.0	100.0	100.0	-	-	-	-	-	-	-	-	
		Compact	5.0	100.0	100.0	100.0	99.3	97.7	-	-	-	-	-	-	-	-	
	ZUUW24GA1 [UUB1 U20]	H-Inverter Standard	5.0	100.0	100.0	100.0	100.0	100.0	-	-	-	-	-	-	-	-	
		Compact	6.8 / 7.5	100.0	99.0	97.8	96.9	94.7	93.4	-	-	-	-	-	-	-	
	ZUUW30GA1 [UUC1 U40]	H-Inverter Standard	6.8 / 8.0	100.0	100.0	100.0	100.0	100.0	100.0	100.0	100.0	100.0	-	-	-	-	
		Compact	6.8 / 8.0	100.0	100.0	100.0	100.0	100.0	99.0	98.1	96.3	-	-	-	-		
	ZUUW48GA1 [UUD1 U30]	H-Inverter	9.5 / 12.0	100.0	100.0	100.0	100.0	100.0	100.0	100.0	100.0	98.5	97.0	95.5	94.8	94.0	93.3
			13.4 / 15.5	100.0	100.0	100.0	98.8	96.3	95.0	93.8	91.3	88.8	86.3	85.0	83.8	82.5	
		Standard	9.5 / 12.0	100.0	100.0	100.0	100.0	98.5	97.8	97.0	95.5	94.0	92.5	91.8	91.0	90.3	
			13.4 / 15.5	100.0	98.8	97.5	96.3	93.8	92.5	91.3	88.8	86.3	83.8	82.5	81.3	80.0	

◆ Rate of change in heating capacity

Piping length (m)		IDU Grade	Capacity (kW)	5	10	15	20	30	35	40	50	60	70	75	80	85
Rate of change in capacity(%)	ZUUW12GA1 [UUA1 U0]	H-Inverter Standard	2.5 / 3.5	100.0	99.8	99.4	99.0	98.3	-	-	-	-	-	-	-	-
		Compact	5.0	100.0	99.8	99.4	99.0	98.3	-	-	-	-	-	-	-	-
	ZUUW24GA1 [UUB1 U20]	H-Inverter Standard	5.0	100.0	99.8	99.4	99.0	98.3	-	-	-	-	-	-	-	-
		Compact	6.8 / 7.5	100.0	99.7	99.2	98.7	97.7	97.2	-	-	-	-	-	-	-
	ZUUW30GA1 [UUC1 U40]	All	6.8 / 7.5 / 9.5	100.0	99.7	99.2	98.7	97.7	97.2	96.6	95.6	-	-	-	-	-
	ZUUW48GA1 [UUD1 U30]	All	9.5 ~ 15.0	100.0	99.7	99.2	98.7	97.7	97.2	96.6	95.6	94.6	93.5	93.0	92.5	92.0

■ 3 Phase Inverter

◆ Rate of change in cooling capacity

Piping length (m)		IDU Grade	Capacity (kW)	5	10	15	20	30	35	40	50	60	70	75	80	85
Rate of change in capacity(%)	ZUUW48LA1 [UUD3 U30]	H-Inverter	9.5 / 12.0	100.0	100.0	100.0	100.0	100.0	100.0	100.0	98.5	97.0	95.5	94.8	94.0	93.3
			13.4 / 15.0	100.0	100.0	100.0	98.8	96.3	95.0	93.8	91.3	88.8	86.3	85.0	83.8	82.5
		Standard	9.5 / 12.0	100.0	100.0	100.0	100.0	98.5	97.8	97.0	95.5	94.0	92.5	91.8	91.0	90.3
			13.4 / 15.0	100.0	98.8	97.5	96.3	93.8	92.5	91.3	88.8	86.3	83.8	82.5	81.3	80.0

◆ Rate of change in heating capacity

Piping length (m)		IDU Grade	Capacity (kW)	5	10	15	20	30	35	40	50	60	70	75	80	85
Rate of change in capacity(%)	ZUUW48LA1 [UUD3 U30]	All	9.5 ~ 15.0	100.0	99.7	99.2	98.7	97.7	97.2	96.6	95.6	94.6	93.5	93.0	92.5	92.0

7. Capacity Correction Factor

7.2 Calculation of actual system capacity

In order to estimate the actual system capacity, the influence of various installation conditions should be reflected.

Reflect the capacity correction factor effect of piping installation as below.

- Q_{odu} [from specification table] : Outdoor unit standard capacity.
- $Q_{(T_i, T_o)}$ [from capacity table] : Outdoor unit capacity at T_i , T_o temperature.
- $F_{(T_i, T_o)} = Q_{(T_i, T_o)} / Q_{\text{(odu.)}}$: Outdoor unit capacity correction factor.
- F_{piping} for piping length [from capacity correction factor table] : Piping correction factor
- Indoor Unit actual capacity

$$Q_{\text{actual}} = Q_{\text{odu}} \times F_{(T_i, T_o)} \times F_{\text{piping}}$$

8. Operation Range

■ ZUUW12GA1 [UUA1 UL0]

◆ H-Inverter / Standard

Cooling

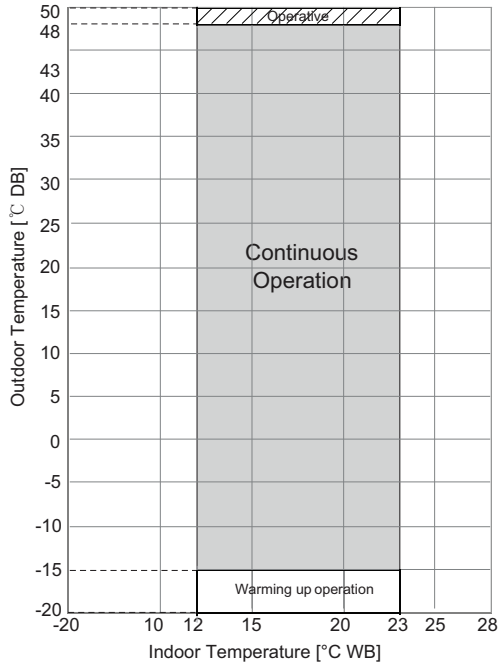

Heating

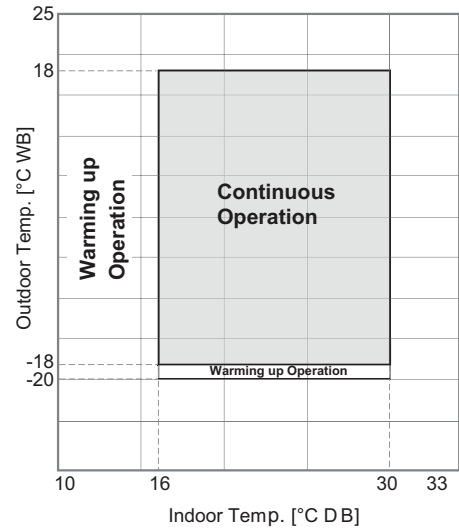

◆ Compact

Cooling

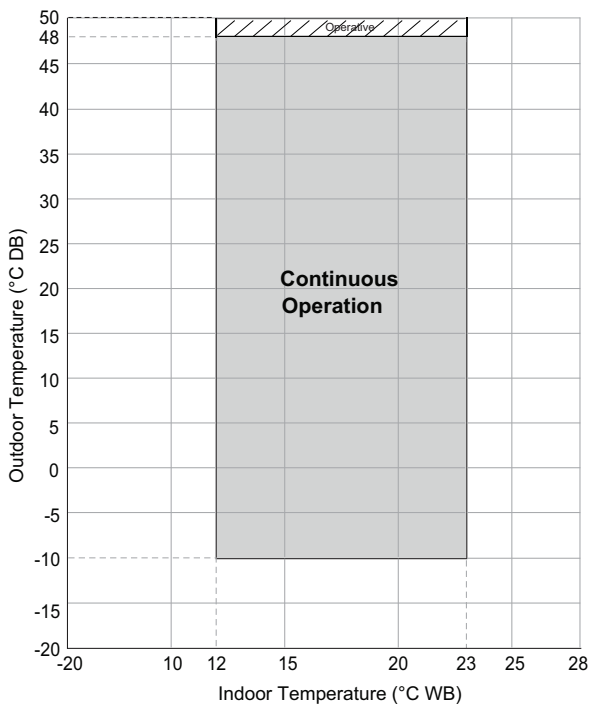

Heating

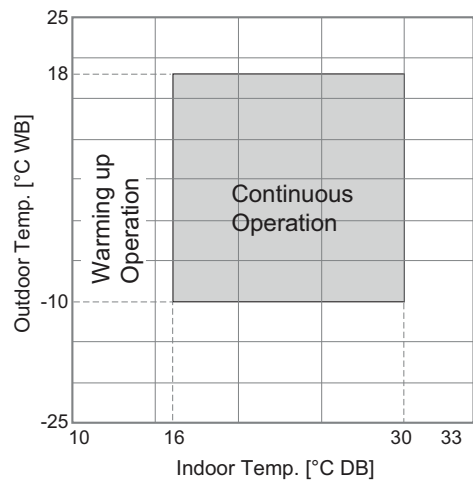

Note

1. Warming up operation and operative mean that the outdoor unit operates to reach the range of continuous operating, however it may not operate continuously due to safety or protection logic.

8. Operation Range

■ ZUUW24GA1 [UUB1 U20]

◆ H-Inverter / Standard

Cooling

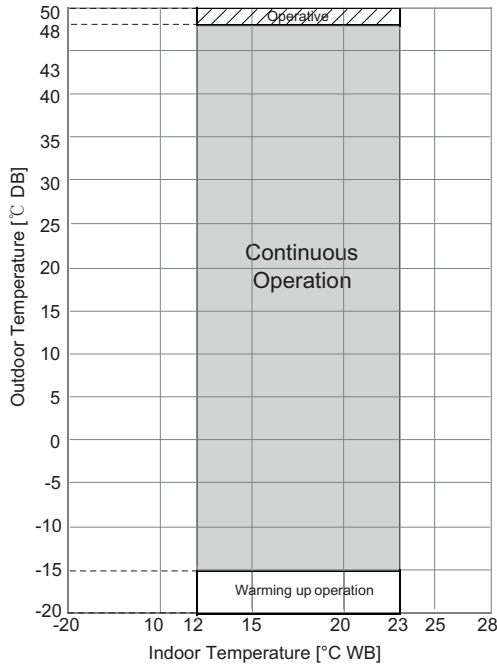

Heating

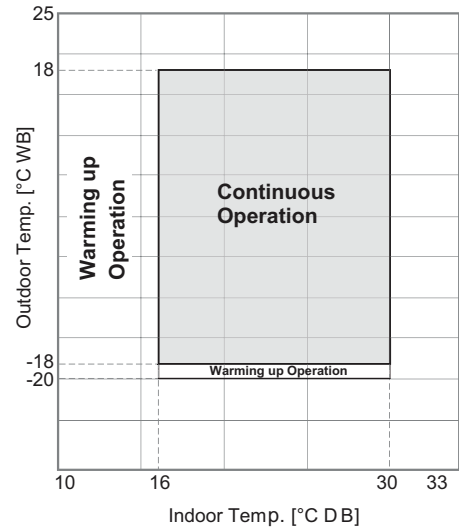

◆ Compact

Cooling

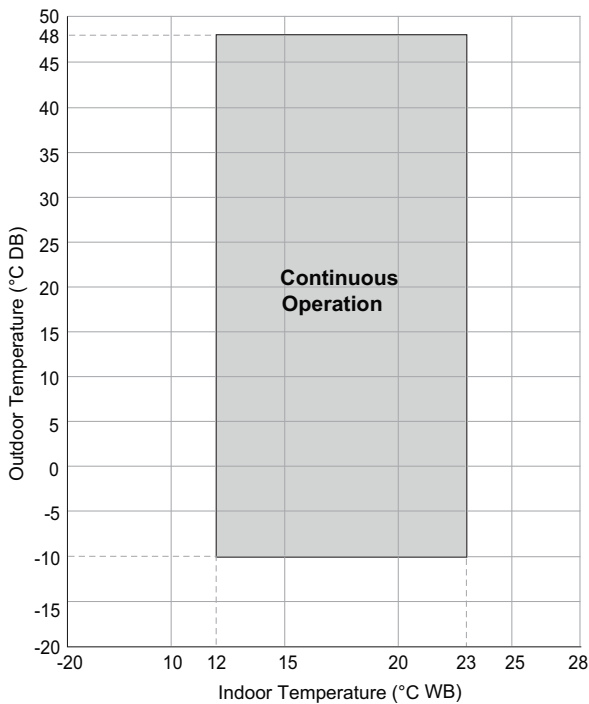

Heating

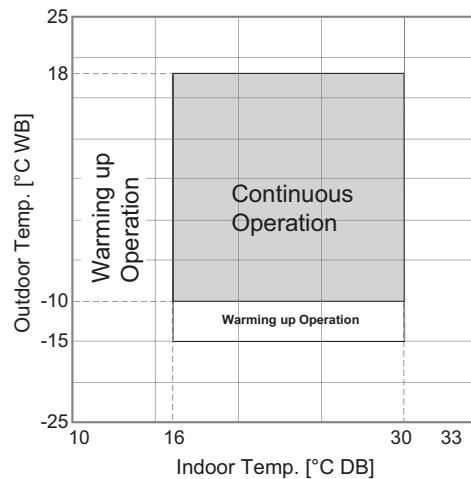

Note

1. Warming up operation and operative mean that the outdoor unit operates to reach the range of continuous operating, however it may not operate continuously due to safety or protection logic.

8. Operation Range

■ ZUUW30GA1 [UUC1 U40]

◆ H-Inverter / Standard

Cooling

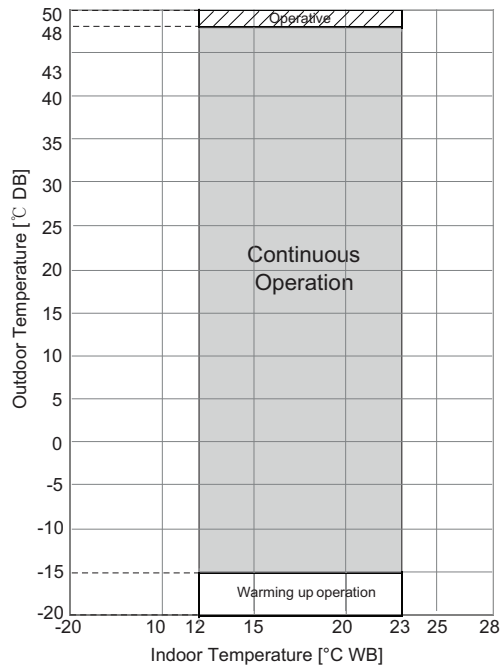

Heating

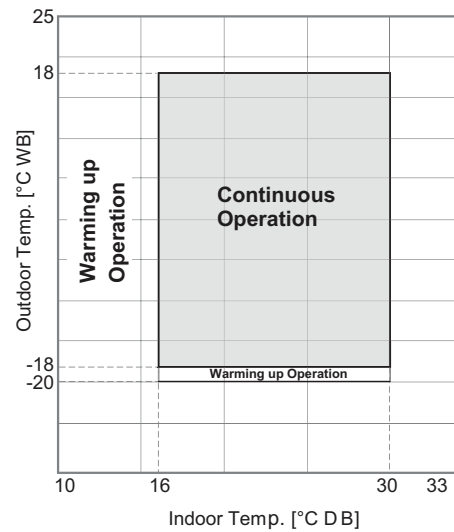

◆ Compact

Cooling

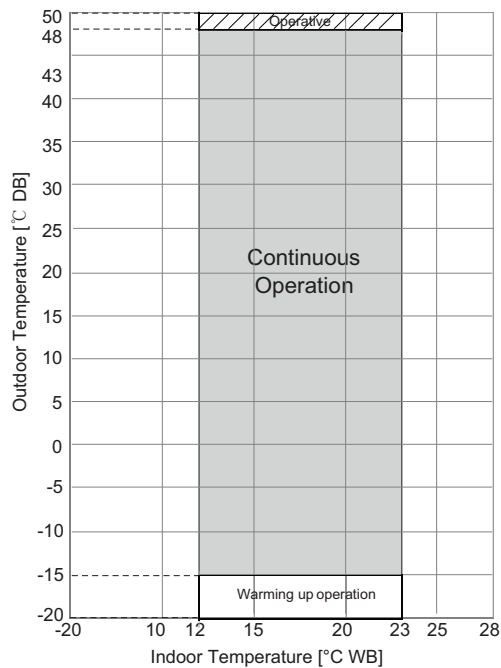

Heating

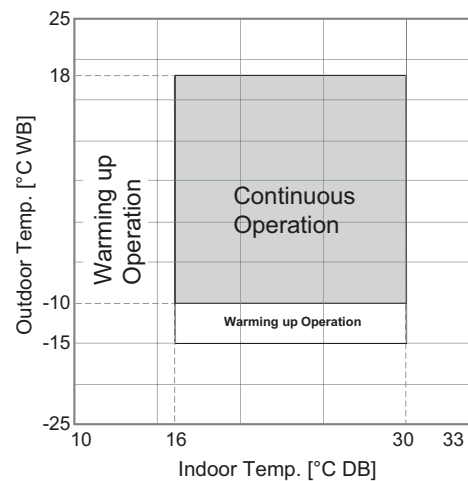

Note

1. Warming up operation and operative mean that the outdoor unit operates to reach the range of continuous operating, however it may not operate continuously due to safety or protection logic.

8. Operation Range

■ ZUUW48GA1 [UUD1 U30], ZUUW48LA1 [UUD3 U30]

◆ H-Inverter / Standard

Cooling

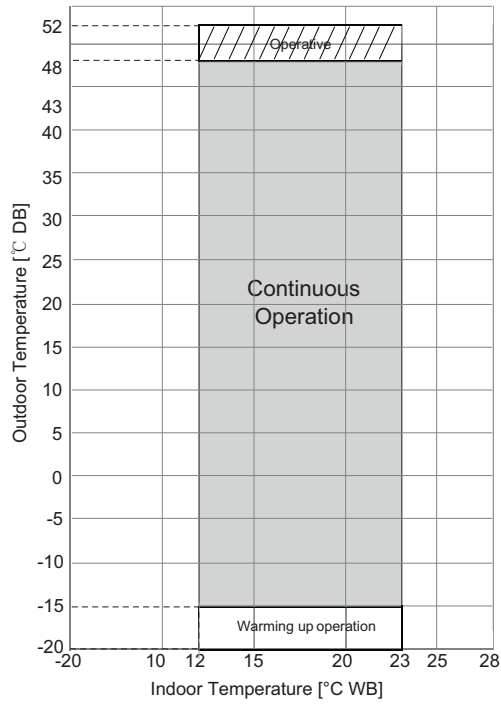

Heating

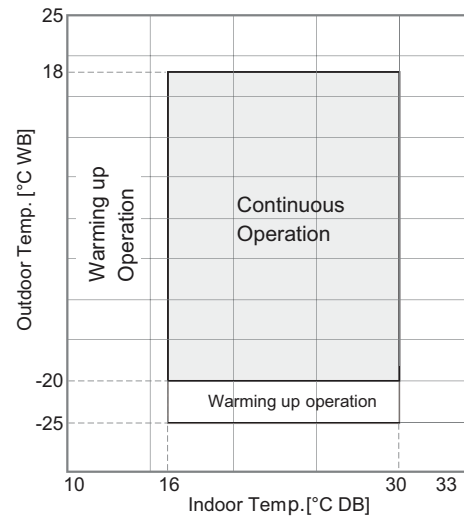

Note

1. Warming up operation and operative mean that the outdoor unit operates to reach the range of continuous operating, however it may not operate continuously due to safety or protection logic.

9. Electric Characteristics

■ Wiring of Main Power Supply and Equipment Capacity

1. The power supply work is needed only to the outdoor unit. The power supply to the indoor unit or the BD unit is conducted through the transmission wiring. Therefore, the power supply work can be carried out at just one place of the outdoor unit. It will contribute to simplify the work procedure and to save cost.
 2. Bear in mind ambient conditions (ambient temperature, direct sunlight, rain liquid, etc.) when proceeding with the wiring and connections
 3. The wire size is the minimum value for metal conduit wiring. The power cord size should be 1 rank thicker taking into account the line voltage drops. Make sure the power-supply voltage does not drop more than 10%.
 4. Specific wiring requirements should adhere to the wiring regulations of the region.
 5. Power supply cords of parts of appliances for outdoor use should not be lighter than polychloroprene sheathed flexible cord.
 6. Don't install an individual switch or electrical outlet to disconnect each of indoor unit separately from the power supply.
-

WARNING

- Follow ordinance of your governmental organization for technical standard related to electrical equipment, wiring regulations and guidance of each electric power company.
 - Make sure to use specified wires for connections so that no external force is imparted to terminal connections. If connections are not fixed firmly, it may cause heating or fire.
 - Make sure to use the appropriate type of overcurrent protection switch. Note that generated overcurrent may include some amount of direct current.
-

CAUTION

- All installation site must require attachment of an earth leakage breaker. If no earth leakage breaker is installed, it may cause an electric shock.
 - Do not use anything other than breaker and fuse with correct capacity. Using fuse and wire or copper wire with too large capacity may cause a malfunction of unit or fire.
-

9. Electric Characteristics

[Field Wiring (Single Phase, 2 Wiring Type)]

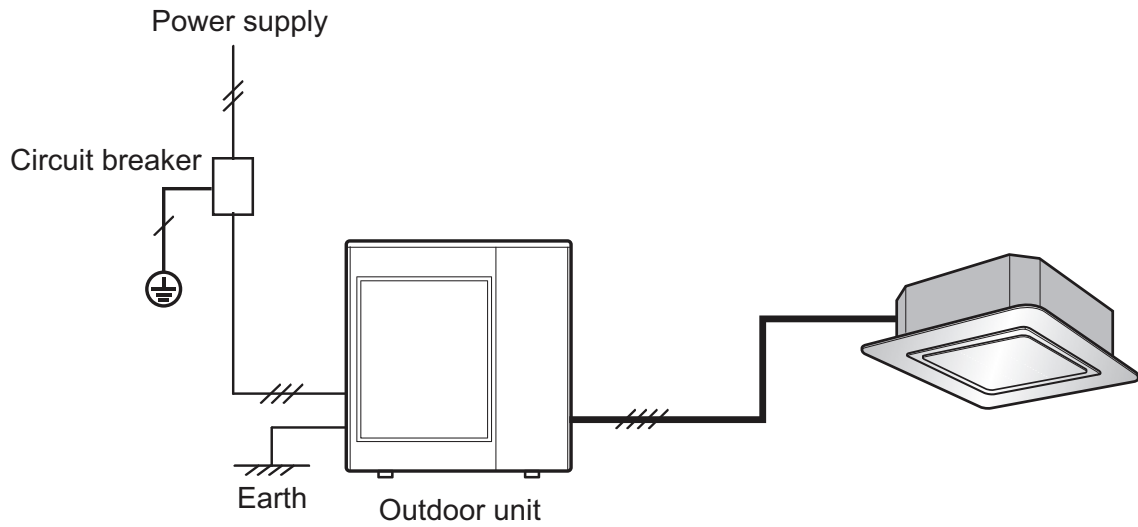

※ This figure is representative example for field wiring. Actual appearance of outdoor and indoor units could be different with installed product.

[Field Wiring (3 Phase, 4 Wiring Type)]

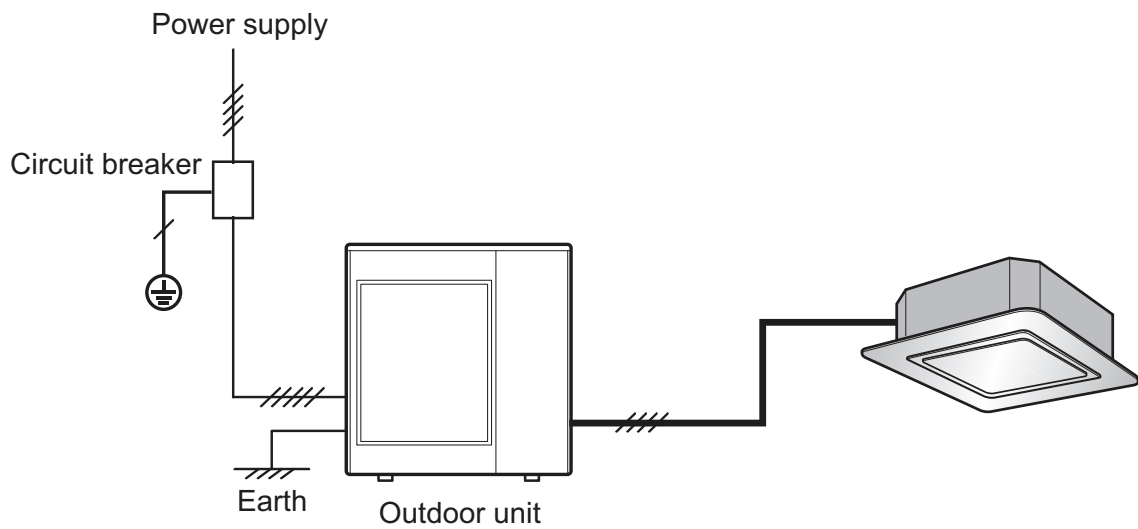

※ This figure is representative example for field wiring. Actual appearance of outdoor and indoor units could be different with installed product.

9. Electric Characteristics

Outdoor Unit	Combined Indoor Unit			Unit	Voltage range	Power		Comp		OFM		IFM	
	Model names	Grade	Model Name			No. of Unit	Phase Hz Volts	MCA	MFA	MSC	RLA	kW	FLA
ZUUW12GA1 [UUA1 UL0]	H-Inverter	ZTNW09GQLH1 [UT09FH NQ0]	1	1 50 220-240	Min. : 198 Max. : 264	11.9	16	-	9.0	0.043	0.25	0.047	0.40
		ZTNW12GQLH1 [UT12FH NQ0]				11.9	16	-	9.0	0.043	0.25	0.047	0.40
		ZBNW12GM1H1 [UM12FH N10]				13.1	16	-	9.0	0.043	0.25	0.188	1.60
		ZBNW12GL5H1 [UL12FH N50]				12.3	16	-	9.0	0.043	0.25	0.094	0.76
	Standard	ZTNW09GRLA1 [CT09F NR0]				11.9	16	-	9.0	0.043	0.25	0.043	0.40
		ZBNW09GL5A1 [CL09F N50]				12.3	16	-	9.0	0.043	0.25	0.024	0.76
		ZQNW09GALA1 [UQ09F NA0]				12.1	16	-	9.0	0.043	0.25	0.030	0.70
		ZMNW09GSJC0 [MJ09PC NSJ]				12.1	16	-	9.0	0.043	0.25	0.030	0.20
		ZTNW12GRLA1 [CT12F NR0]				11.9	16	-	9.0	0.043	0.25	0.043	0.40
		ZBNW12GL5A1 [CL12F N50]				12.3	16	-	9.0	0.043	0.25	0.024	0.76
		ZQNW12GALA1 [UQ12F NA0]				12.1	16	-	9.0	0.043	0.25	0.030	0.70
		ZMNW12GSJC0 [MJ12PC NSJ]				12.1	16	-	9.0	0.043	0.25	0.030	0.20
	Compact	ZTNW18GQLA1 [CT18F NQ0]				11.9	16	-	9.0	0.043	0.25	0.047	0.40
		ZBNW18GM1A 2 [CM18F N11]				13.1	16	-	9.0	0.043	0.25	0.188	1.60
		ZBNW18GMAA0 [CM18F NA0]				13.1	16	-	9.0	0.043	0.25	0.165	1.70
		ZBNW18GL6A1 [CL18F N60]				12.3	16	-	9.0	0.043	0.25	0.094	0.80
		ZVNW18GM1A1 [UV18F N10]				12.5	16	-	9.0	0.043	0.25	0.117	1.00

Note

1. Voltage supplied to the unit terminals should be within the minimum and maximum range.
2. Maximum allowable voltage unbalance between phase is 2%.
3. MSC means the Max. current during the starting of compressor.
4. MSC and RLA are measured as the compressor only test condition.
5. OFM and IFM are measured as the air conditioner unit test condition.
6. Select the wire size based on the MCA.
7. MFA is used to select the circuit breaker and ground fault circuit interrupter, and all installation site must require attachment of an earth leakage breaker. [circuit breaker type is ELCB(Earth Leakage Circuit Breaker)].

Symbols

MCA : Minimum Circuit Amperes (A)
MFA : Maximum Fuse Amperes (A)
MSC : Maximum Starting Current (A)
RLA : Rated Load Amperes (A)
OFM : Outdoor Fan Motor
IFM : Indoor Fan Motor
kW : Fan Motor rated output (kW)
FLA : Full Load Amperes (A)

9. Electric Characteristics

Outdoor Unit	Combined Indoor Unit			Unit	Voltage range	Power		Comp		OFM		IFM	
Model names	Grade	Model Name	No. of Unit	Phase Hz Volts		MCA	MFA	MSC	RLA	kW	FLA	kW	FLA
ZUUW24GA1 [UUB1 U20]	H-Inverter	ZTNW18GBLH1 [UT18FH NB0]	1	1 50 220-240	Min. : 198 Max. : 264	16.0	20	-	12.0	0.085	0.40	0.070	0.60
		ZBNW18GM1H1 [UM18FH N10]				17.0	20	-	12.0	0.085	0.40	0.188	1.60
		ZBNW18GL3H1 [UL18FH N30]				16.4	20	-	12.0	0.085	0.40	0.117	1.00
		ZVNW18GM1H1 [UV18FH N10]				16.4	20	-	12.0	0.085	0.40	0.117	1.00
	Standard	ZTNW18GCLA1 [CT18F NQ0]				15.8	20	-	12.0	0.085	0.40	0.047	0.40
		ZBNW18GM1A2 [CM18F N11]				17.0	20	-	12.0	0.085	0.40	0.188	1.60
		ZBNW18GMAA0 [CM18F NAO]				17.0	20	-	12.0	0.085	0.40	0.165	1.70
		ZBNW18GL6A1 [CL18F N60]				16.2	20	-	12.0	0.085	0.40	0.094	0.97
		ZVNW18GM1A1 [UV18F N10]				16.4	20	-	12.0	0.085	0.40	0.117	1.00
		ZQNW18GALA1 [UQ18F NAO]				16.1	20	-	12.0	0.085	0.40	0.082	0.70
	Compact	ZMNW18GSKC0 [MJ18PC NSK]				16.0	20	-	12.0	0.085	0.40	0.030	0.40
		ZTNW24GBLA1 [CT24F NB0]				16.0	20	-	12.0	0.085	0.40	0.070	0.60
		ZBNW24GM1A2 [CM24F N11]				17.0	20	-	12.0	0.085	0.40	0.188	1.60
		ZBNW24GL3A1 [CL24F N30]				16.4	20	-	12.0	0.085	0.40	0.117	1.00
		ZVNW24GM1A1 [UV24F N10]				16.4	20	-	12.0	0.085	0.40	0.117	1.00
		ZBNW24GMAA0 [CM24F NAO]				17.0	20	-	12.0	0.085	0.40	0.165	1.70
		ZBNW30GMAA0 [UM30F NAO]				17.0	20	-	12.0	0.085	0.40	0.165	1.70
		ZJNW30GRLA1 [US30F NR0]				16.3	20	-	12.0	0.085	0.40	0.106	0.90
		ZTNW30GBLA1 [UT30F NB0]				16.0	20	-	12.0	0.085	0.40	0.070	0.60
		ZBNW30GM1A2 [UM30F N11]				17.0	20	-	12.0	0.085	0.40	0.188	1.60
ZVNW30GM1A1 [UV30F N10]	16.4	20	-	12.0	0.085	0.40	0.117	1.00					

Note

- Voltage supplied to the unit terminals should be within the minimum and maximum range.
- Maximum allowable voltage unbalance between phase is 2%.
- MSC means the Max. current during the starting of compressor.
- MSC and RLA are measured as the compressor only test condition.
- OFM and IFM are measured as the air conditioner unit test condition.
- Select the wire size based on the MCA.
- MFA is used to select the circuit breaker and ground fault circuit interrupter, and all installation site must require attachment of an earth leakage breaker. [circuit breaker type is ELCB(Earth Leakage Circuit Breaker)].

Symbols

MCA : Minimum Circuit Amperes (A)
MFA : Maximum Fuse Amperes (A)
MSC : Maximum Starting Current (A)
RLA : Rated Load Amperes (A)
OFM : Outdoor Fan Motor
IFM : Indoor Fan Motor
kW : Fan Motor rated output (kW)
FLA : Full Load Amperes (A)

9. Electric Characteristics

Outdoor Unit Model names	Combined Indoor Unit			Unit		Power		Comp		OFM		IFM	
	Grade	Model Name	No. of Unit	Phase Hz Volts	Voltage range	MCA	MFA	MSC	RLA	kW	FLA	kW	FLA
ZUUW30GA1 [UUC1 U40]	H-Inverter	ZTNW24GALH1 [UT24FH NA0]	1	1 50 220-240	Min. : 198 Max. : 264	22.7	25	-	17.0	0.124	0.48	0.117	1.00
		ZBNW24GM2H1 [UM24FH N20]				24.0	25	-	17.0	0.124	0.48	0.270	2.30
		ZVNW24GM2H1 [UV24FH N20]				22.7	25	-	17.0	0.124	0.48	0.114	0.97
		ZTNW30GALH1 [UT30FH NA0]				22.7	25	-	17.0	0.124	0.48	0.117	1.00
		ZBNW30GM2H1 [UM30FH N20]				24.0	25	-	17.0	0.124	0.48	0.270	2.30
		ZVNW30GM2H1 [UV30FH N20]				22.7	25	-	17.0	0.124	0.48	0.114	0.97
	Standard	ZTNW24GBLA1 [CT24F NB0]				22.3	25	-	17.0	0.124	0.48	0.070	0.60
		ZBNW24GM1A2 [CM24F N11]				23.3	25	-	17.0	0.124	0.48	0.188	1.60
		ZBNW24GMAA0 [CM24F NA0]				23.3	25	-	17.0	0.124	0.48	0.165	1.70
		ZBNW24GL3A1 [CL24F N30]				22.7	25	-	17.0	0.124	0.48	0.117	1.00
		ZVNW24GM1A1 [UV24F N10]				22.7	25	-	17.0	0.124	0.48	0.117	1.00
		ZMNV24GSKC0 [MJ24PC NSK]				22.5	25	-	17.0	0.124	0.48	0.058	0.40
		ZJNW30GRLA1 [US30F NR0]				22.6	25	-	17.0	0.124	0.48	0.106	0.90
		ZTNW30GBLA1 [UT30F NB0]				22.3	25	-	17.0	0.124	0.48	0.070	0.60
		ZBNW30GM1A2 [UM30F N11]				23.3	25	-	17.0	0.124	0.48	0.188	1.60
		ZBNW30GMAA0 [UM30F NA0]				23.3	25	-	17.0	0.124	0.48	0.165	1.70
		ZVNW30GM1A1 [UV30F N10]				22.7	25	-	17.0	0.124	0.48	0.117	1.00
		Compact				ZJNW36GRLA1 [US36F NR0]	22.6	25	-	17.0	0.124	0.48	0.106
	ZTNW36GALA1 [UT36F NA0]					22.7	25	-	17.0	0.124	0.48	0.117	1.00
	ZBNW36GM2A2 [UM36F N21]					24.0	25	-	17.0	0.124	0.48	0.270	2.30
ZVNW36GM2A1 [UV36F N20]	22.7		25	-	17.0	0.124	0.48	0.114	0.97				

Note

- Voltage supplied to the unit terminals should be within the minimum and maximum range.
- Maximum allowable voltage unbalance between phase is 2%.
- MSC means the Max. current during the starting of compressor.
- MSC and RLA are measured as the compressor only test condition.
- OFM and IFM are measured as the air conditioner unit test condition.
- Select the wire size based on the MCA.
- MFA is used to select the circuit breaker and ground fault circuit interrupter, and all installation site must require attachment of an earth leakage breaker. [circuit breaker type is ELCB(Earth Leakage Circuit Breaker)].

Symbols

MCA : Minimum Circuit Amperes (A)
MFA : Maximum Fuse Amperes (A)
MSC : Maximum Starting Current (A)
RLA : Rated Load Amperes (A)
OFM : Outdoor Fan Motor
IFM : Indoor Fan Motor
kW : Fan Motor rated output (kW)
FLA : Full Load Amperes (A)

9. Electric Characteristics

Outdoor Unit		Combined Indoor Unit			Unit		Power		Comp		OFM		IFM	
Model names	Grade	Model Name	No. of Unit	Phase Hz Volts	Voltage range	MCA	MFA	MSC	RLA	kW	FLA	kW	FLA	
ZUUW48GA1 [UUD1 U30]	H-Inverter	ZTNW36GALH1 [UT36FH NA0]	1	50 220-240	Min. : 198 Max. : 264	34.6	40	-	25.6	0.248	1.60	0.117	1.00	
		ZBNW36GM3H1 [UM36FH N30]				36.1	40	-	25.6	0.248	1.60	0.293	2.50	
		ZVNW36GM2H1 [UV36FH N20]				34.6	40	-	25.6	0.248	1.60	0.114	0.97	
		ZTNW42GALH1 [UT42FH NA0]				34.6	40	-	25.6	0.248	1.60	0.117	1.00	
		ZBNW42GM3H1 [UM42FH N30]				36.1	40	-	25.6	0.248	1.60	0.293	2.50	
		ZVNW42GM2H1 [UV42FH N20]				34.6	40	-	25.6	0.248	1.60	0.114	0.97	
		ZTNW48GALH1 [UT48FH NA0]				34.6	40	-	25.6	0.248	1.60	0.117	1.00	
		ZBNW48GM3H1 [UM48FH N30]				36.1	40	-	25.6	0.248	1.60	0.293	2.50	
		ZTNW60GALH1 [UT60FH NA0]				34.6	40	-	25.6	0.248	1.60	0.117	1.00	
	Standard	ZJNW36GRLA1 [US36F NR0]				34.5	40	-	25.6	0.248	1.60	0.106	0.90	
		ZTNW36GALA1 [UT36F NA0]				34.6	40	-	25.6	0.248	1.60	0.117	1.00	
		ZBNW36GM2A2 [UM36F N21]				35.9	40	-	25.6	0.248	1.60	0.270	2.30	
		ZVNW36GM2A1 [UV36F N20]				34.6	40	-	25.6	0.248	1.60	0.114	0.97	
		ZTNW36GYLA0 [UT36F NY0]				34.6	40	-	25.6	0.248	1.60	0.146	1.20	
		ZTNW42GALA1 [UT42F NA0]				34.6	40	-	25.6	0.248	1.60	0.117	1.00	
		ZBNW42GM2A2 [UM42F N21]				35.9	40	-	25.6	0.248	1.60	0.270	2.30	
		ZVNW42GM2A1 [UV42F N20]				34.6	40	-	25.6	0.248	1.60	0.114	0.97	
		ZTNW48GALA1 [UT48F NA0]				34.6	40	-	25.6	0.248	1.60	0.117	1.00	
		ZBNW48GM3A2 [UM48F N31]				36.1	40	-	25.6	0.248	1.60	0.293	2.50	
		ZVNW48GM2A1 [UV48F N20]				34.6	40	-	25.6	0.248	1.60	0.114	0.97	
		ZTNW48GYLA0 [UT48F NY0]				34.6	40	-	25.6	0.248	1.60	0.146	1.20	
		ZTNW60GALA1 [UT60F NA0]				34.6	40	-	25.6	0.248	1.60	0.117	1.00	
		ZBNW60GM3A2 [UM60F N31]				36.1	40	-	25.6	0.248	1.60	0.293	2.50	
		ZVNW60GM2A1 [UV60F N20]				34.6	40	-	25.6	0.248	1.60	0.114	0.97	

Note

1. Voltage supplied to the unit terminals should be within the minimum and maximum range.
2. Maximum allowable voltage unbalance between phase is 2%.
3. MSC means the Max. current during the starting of compressor.
4. MSC and RLA are measured as the compressor only test condition.
5. OFM and IFM are measured as the air conditioner unit test condition.
6. Select the wire size based on the MCA.
7. MFA is used to select the circuit breaker and ground fault circuit interrupter, and all installation site must require attachment of an earth leakage breaker. [circuit breaker type is ELCB(Earth Leakage Circuit Breaker)].

Symbols

MCA : Minimum Circuit Amperes (A)
MFA : Maximum Fuse Amperes (A)
MSC : Maximum Starting Current (A)
RLA : Rated Load Amperes (A)
OFM : Outdoor Fan Motor
IFM : Indoor Fan Motor
kW : Fan Motor rated output (kW)
FLA : Full Load Amperes (A)

9. Electric Characteristics

Outdoor Unit		Combined Indoor Unit		Unit		Power		Comp		OFM		IFM	
Model names	Grade	Model Name	No. of Unit	Phase Hz Volts	Voltage range	MCA	MFA	MSC	RLA	kW	FLA	kW	FLA
ZUUW48LA1 [UUD3 U30]	H-Inverter	ZTNW36GALH1 [UT36FH NA0]	1	3 50 380-415	Min. : 342 Max. : 456	15.1	20	-	10.0	0.248	1.60	0.117	1.00
		ZBNW36GM3H1 [UM36FH N30]				16.6	20	-	10.0	0.248	1.60	0.293	2.50
		ZVNW36GM2H1 [UV36FH N20]				15.1	20	-	10.0	0.248	1.60	0.114	0.97
		ZTNW42GALH1 [UT42FH NA0]				15.1	20	-	10.0	0.248	1.60	0.117	1.00
		ZBNW42GM3H1 [UM42FH N30]				16.6	20	-	10.0	0.248	1.60	0.293	2.50
		ZVNW42GM2H1 [UV42FH N20]				15.1	20	-	10.0	0.248	1.60	0.114	0.97
		ZTNW48GALH1 [UT48FH NA0]				15.1	20	-	10.0	0.248	1.60	0.117	1.00
		ZBNW48GM3H1 [UM48FH N30]				16.6	20	-	10.0	0.248	1.60	0.293	2.50
		ZTNW60GALH1 [UT60FH NA0]				15.1	20	-	10.0	0.248	1.60	0.117	1.00
		ZJNW36GRLA1 [US36F NR0]				15.0	20	-	10.0	0.248	1.60	0.106	0.90
	Standard	ZTNW36GALA1 [UT36F NA0]				15.1	20	-	10.0	0.248	1.60	0.117	1.00
		ZBNW36GM2A2 [UM36F N21]				16.4	20	-	10.0	0.248	1.60	0.270	2.30
		ZVNW36GM2A1 [UV36F N20]				15.1	20	-	10.0	0.248	1.60	0.114	0.97
		ZTNW36GYLA0 [UT36F NY0]				15.1	20	-	10.0	0.248	1.60	0.146	1.20
		ZTNW42GALA1 [UT42F NA0]				15.1	20	-	10.0	0.248	1.60	0.117	1.00
		ZBNW42GM2A2 [UM42F N21]				16.4	20	-	10.0	0.248	1.60	0.270	2.30
		ZVNW42GM2A1 [UV42F N20]				15.1	20	-	10.0	0.248	1.60	0.114	0.97
		ZTNW48GALA1 [UT48F NA0]				15.1	20	-	10.0	0.248	1.60	0.117	1.00
		ZBNW48GM3A2 [UM48F N31]				16.6	20	-	10.0	0.248	1.60	0.293	2.50
		ZVNW48GM2A1 [UV48F N20]				15.1	20	-	10.0	0.248	1.60	0.114	0.97

Note

1. Voltage supplied to the unit terminals should be within the minimum and maximum range.
2. Maximum allowable voltage unbalance between phase is 2%.
3. MSC means the Max. current during the starting of compressor.
4. MSC and RLA are measured as the compressor only test condition.
5. OFM and IFM are measured as the air conditioner unit test condition.
6. Select the wire size based on the MCA.
7. MFA is used to select the circuit breaker and ground fault circuit interrupter, and all installation site must require attachment of an earth leakage breaker. [circuit breaker type is ELCB(Earth Leakage Circuit Breaker)].

Symbols

- MCA** : Minimum Circuit Amperes (A)
- MFA** : Maximum Fuse Amperes (A)
- MSC** : Maximum Starting Current (A)
- RLA** : Rated Load Amperes (A)
- OFM** : Outdoor Fan Motor
- IFM** : Indoor Fan Motor
- kW** : Fan Motor rated output (kW)
- FLA** : Full Load Amperes (A)

10. Sound Levels

10.1 Sound Pressure Levels

Overall

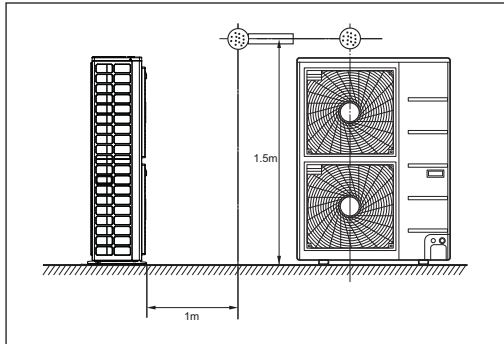

Note

1. Sound measured at some distance away from the center of the unit.
2. Data is valid at free field condition.
3. Reference acoustic pressure 0dB = 20μPa.
4. Data is valid at nominal operation condition.
Refer to the Model Specifications for nominal conditions (Power source and Ambient temperature, etc)
5. Sound levels can be increased in accordance with installation and operating conditions. (Static pressure mode, used air guide, Room target temperature setting, etc)
6. Sound level will vary depending on a range of factors such as the construction (acoustic absorption coefficient) of particular room in which the equipment is installed.
7. Sound pressure level is measured on the rated condition in the anechoic rooms. (LG Internal Standard)
Therefore, these values can be increased owing to ambient conditions during operation.

Model	Combined Indoor Unit Capacity (kBtu/h)	Sound Pressure Levels [dB(A)]	
		Cooling	Heating
ZUUW12GA1 [UUA1 UL0]	9 / 12 / 18	49	52
ZUUW24GA1 [UUB1 U20]	18	47	52
	24	48	53
	30	50	54
ZUUW30GA1 [UUC1 U40]	24	48	52
	30	50	52
	36	54	56
ZUUW48GA1 [UUD1 U30] ZUUW48LA1 [UUD3 U30]	36	50	50
	42	51	52
	48	52	53
	60	54	54

10. Sound Levels

ZUUW12GA1 [UUA1 UL0]
+ 9/12/18k indoor units

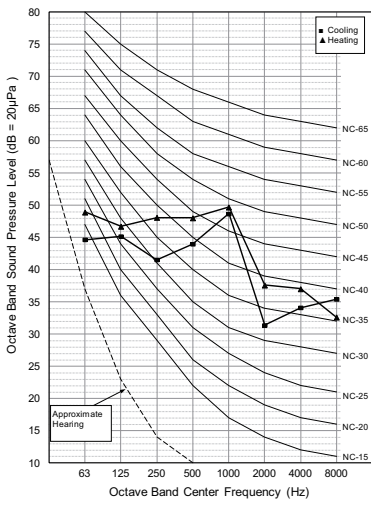

ZUUW24GA1 [UUB1 U20]
+ 18k indoor units

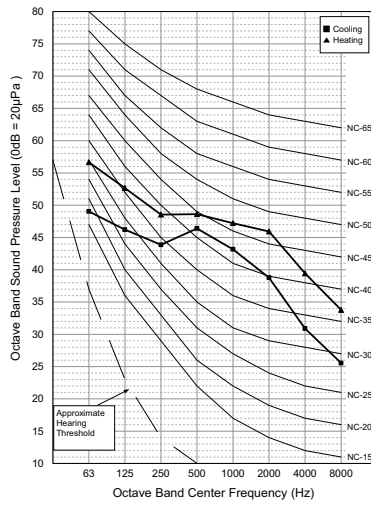

ZUUW24GA1 [UUB1 U20]
+ 24k indoor units

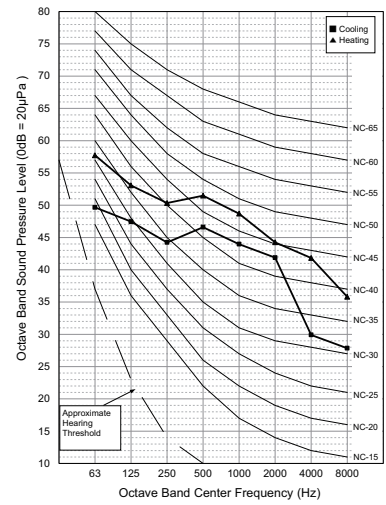

ZUUW24GA1 [UUB1 U20]
+ 30k indoor units

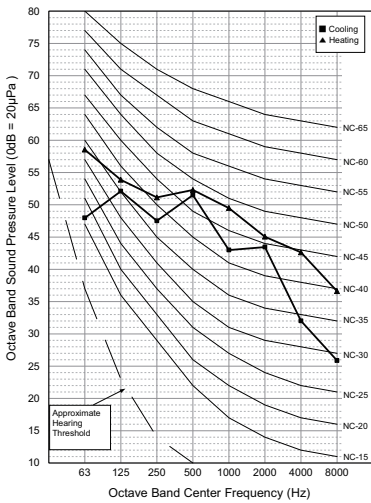

ZUUW30GA1 [UUC1 U40]
+ 24k indoor units

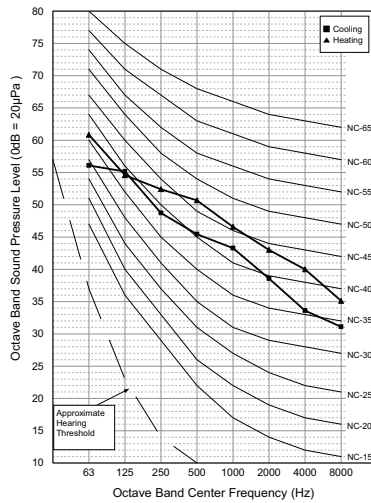

ZUUW30GA1 [UUC1 U40]
+ 30k indoor units

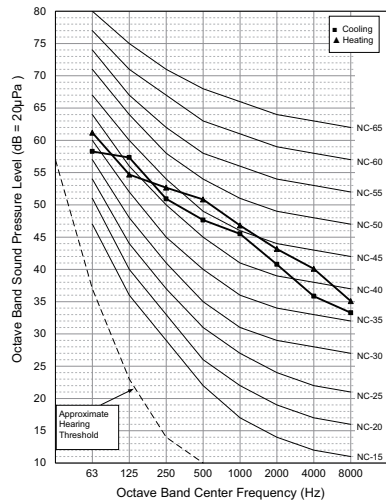

ZUUW30GA1 [UUC1 U40]
+ 36k indoor units

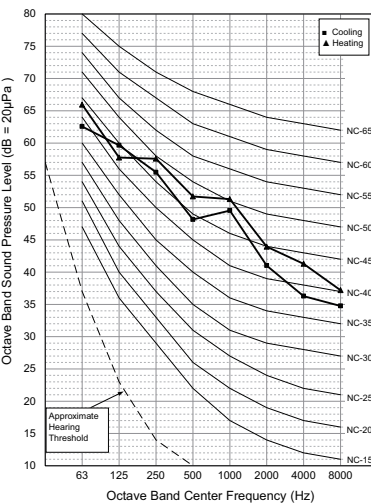

ZUUW48GA1 [UUD1 U30]
ZUUW48LA1 [UUD3 U30]
+ 36k indoor units

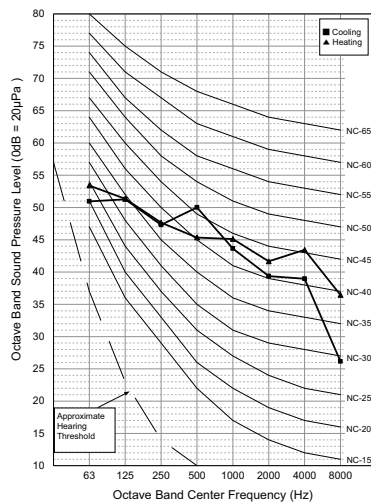

ZUUW48GA1 [UUD1 U30]
ZUUW48LA1 [UUD3 U30]
+ 42k indoor units

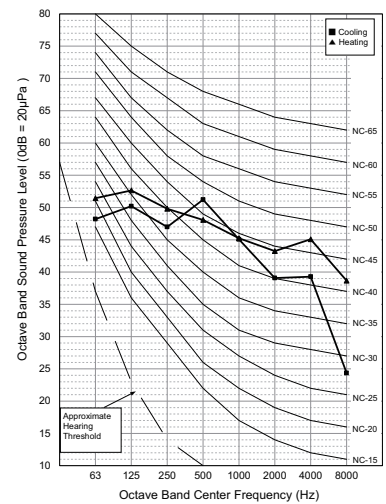

10. Sound Levels

**ZUUW48GA1 [UUD1 U30]
ZUUW48LA1 [UUD3 U30]
+ 48k indoor units**

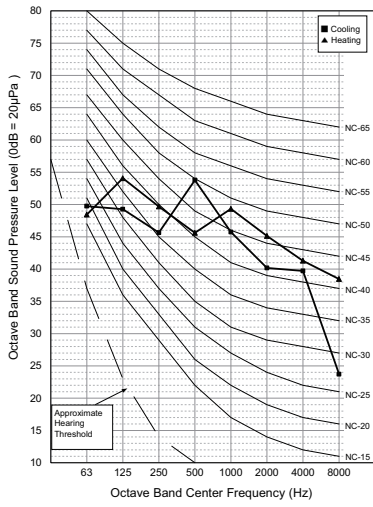

**ZUUW48GA1 [UUD1 U30]
ZUUW48LA1 [UUD3 U30]
+ 60k indoor units**

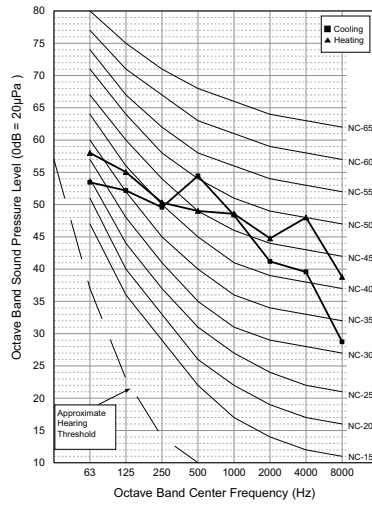

10. Sound Levels

10.2 Sound Power Levels

Note

1. Data is valid at diffuse field condition.
2. Data is valid at nominal operating condition
Refer to the Model Specifications for nominal conditions(Power source and Ambient temperature, etc).
3. Sound level can be increased in static pressure mode or used air guide.
4. Sound level will vary depending on a range of factors such as the construction (acoustic absorption coefficient).
5. Reference acoustic intensity 0dB = $10E-6\mu W/m^2$
6. Sound power level is measured on the rated condition in the reverberation rooms by ISO 3741 standard.
Therefore, these values can be increased owing to ambient conditions during operation.

Model	Combined Indoor Unit Capacity (kBtu/h)	Sound Power Levels [dB(A)]
		Cooling
ZUUW12GA1 [UUA1 UL0]	9 / 12 / 18	65
ZUUW24GA1 [UUB1 U20]	18	63
	24	65
	30	67
ZUUW30GA1 [UUC1 U40]	24	65
	30	68
	36	70
ZUUW48GA1 [UUD1 U30] ZUUW48LA1 [UUD3 U30]	36	66
	42	69
	48	69
	60	71

10. Sound Levels

ZU UW12GA1 [UUA1 UL0]
+ 9/12/18k indoor units

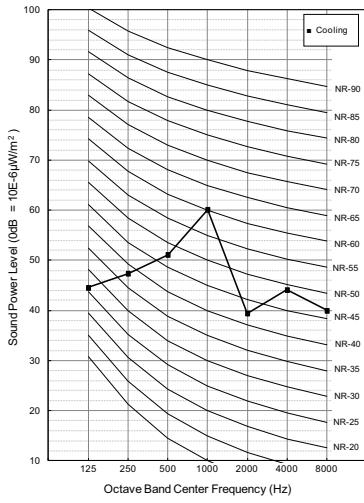

ZU UW24GA1 [UUB1 U20]
+ 18k indoor units

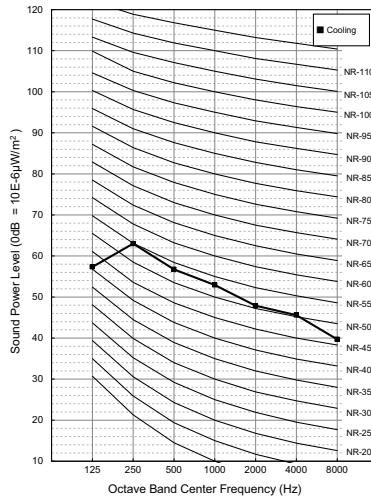

ZU UW24GA1 [UUB1 U20]
+ 24k indoor units

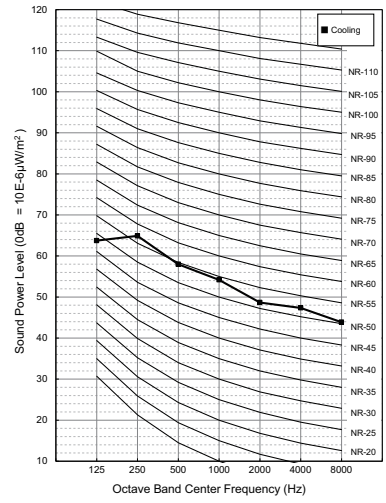

ZU UW24GA1 [UUB1 U20]
+ 30k indoor units

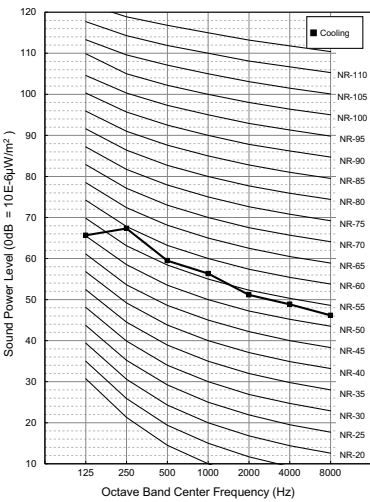

ZU UW30GA1 [UUC1 U40]
+ 24k indoor units

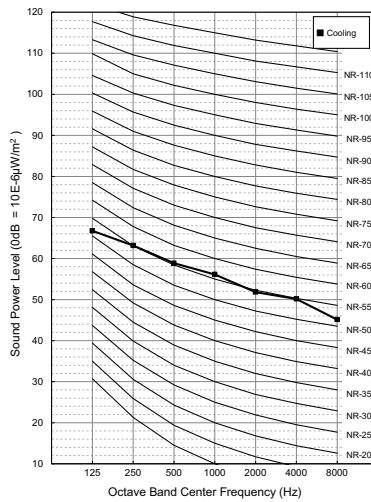

ZU UW30GA1 [UUC1 U40]
+ 30k indoor units

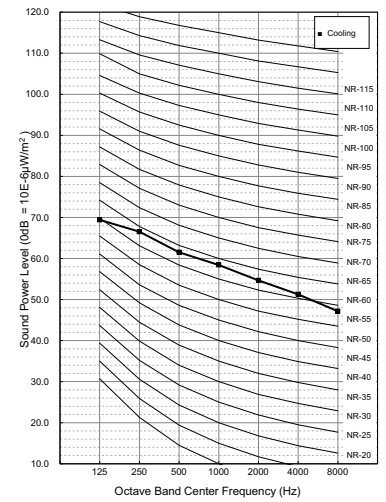

ZU UW30GA1 [UUC1 U40]
+ 36k indoor units

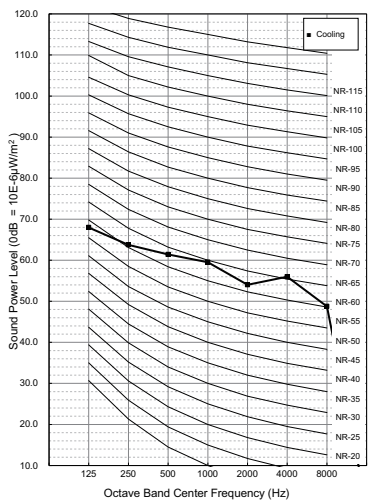

ZU UW48GA1 [UUD1 U30]
ZU UW48LA1 [UUD3 U30]
+ 36k indoor units

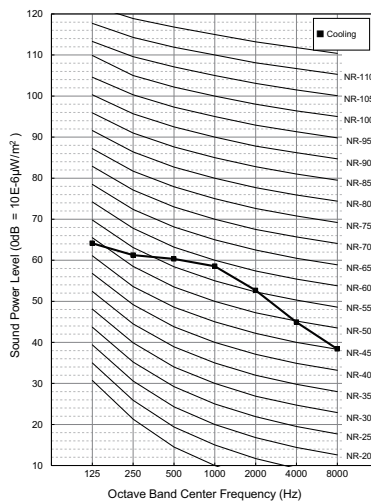

ZU UW48GA1 [UUD1 U30]
ZU UW48LA1 [UUD3 U30]
+ 42k indoor units

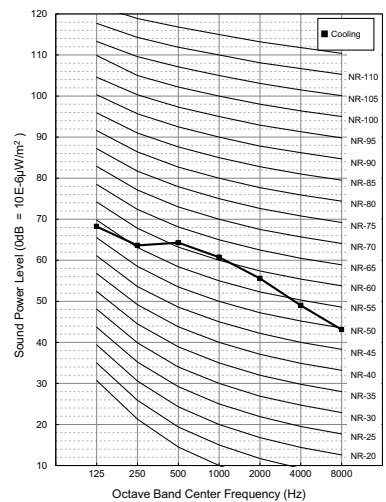

10. Sound Levels

**ZUUW48GA1 [UUD1 U30]
ZUUW48LA1 [UUD3 U30]
+ 48k indoor units**

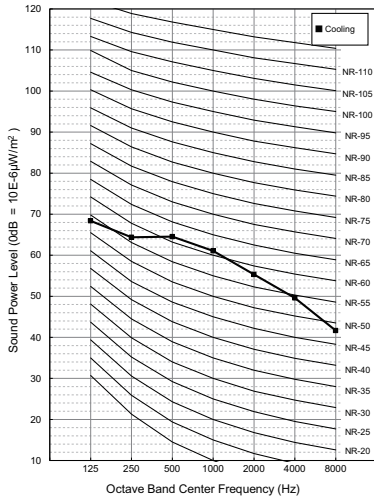

**ZUUW48GA1 [UUD1 U30]
ZUUW48LA1 [UUD3 U30]
+ 60k indoor units**

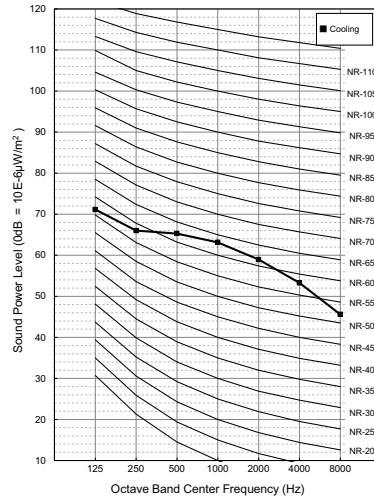

SINGLE

Outdoor Unit

Outdoor Units - Synchro

- 1.Power Supply**
- 2.List of Functions**
- 3.Combination Table**
- 4.Piping Length & Height**
- 5.Simultaneous Operation Setting**
- 6.Piping Diagrams**
- 7.Accessories**

1. Power Supply

Type	OutdoorUnit	Capacity(kW)	Circuit BreakerCapacity	PowerSupply
1 Phase Inverter	ZUUW48GA1 [UUD1 U30]	9.5 ~ 14.6	40 A	1Ø, 220-240 V, 50Hz
3 Phase Inverter	ZUUW48LA1 [UUD3 U30]	9.5 ~ 14.6	20 A	3Ø, 380-415 V, 50Hz

External wiring procedure

- The power supply work is needed only to the outdoor unit. The power supply to the indoor unit is conducted through the transmission wiring. Therefore, the power supply work can be carried out at just one place of the outdoor unit. It will contribute to simplify the work procedure and to save cost.
- Wiring cable size must comply with the applicable local and national code.

(Ex. Duo simultaneous operation)

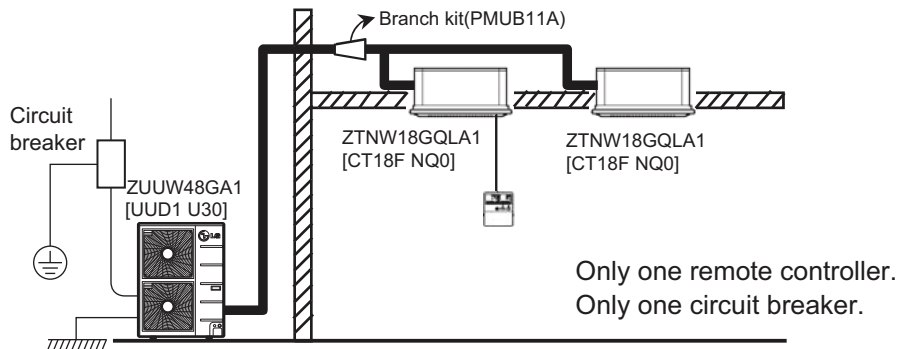

(Ex. Trio simultaneous operation)

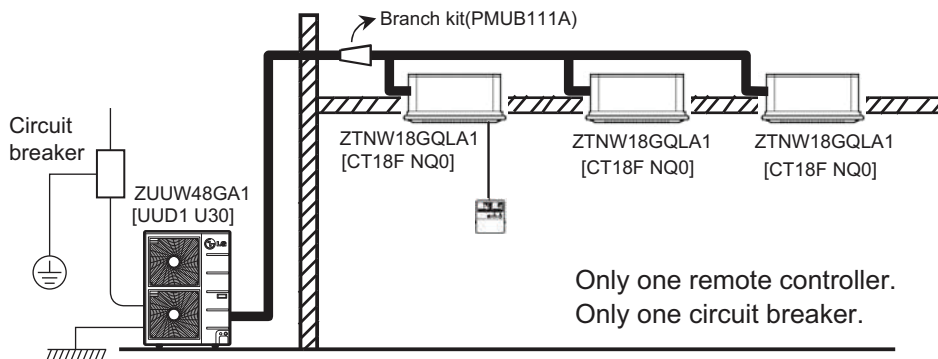

(Ex. Quartets imultaneous operation)

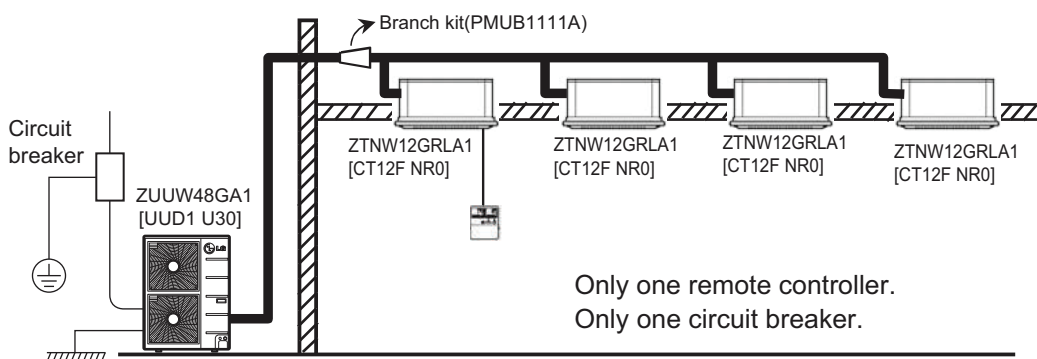

2. List of Functions

■ 1 Phase Inverter - Synchro

◆ List of function

Category	Functions	ZUUW48GA1 [UUD1 U30]
Reliability	Defrost / Deicing	O
	High pressure switch	O
	Low pressure switch	X
	Phase protection	X
	Restart delay (3-minutes)	O
	Self diagnosis	O
	Soft start	O
Convenience	Test function	O
	Night Low Noise Operation	O
	Wiring Error Check	X
	Peak Control	X
	Mode Lock	X
	Forced Cooling Operation (Outdoor Unit)	O
	SLC(Smart Load Control)	X
Network function	Network solution(LGAP)	O
ODU Dry Contact		X

Note

1. O : Applied, X : Not applied

Accessory : Ordered and purchased separately the accessory package referring to the model name provided and install at field.

Accessory line-ups varies by region, so check your local catalogue or local sales material.

◆ Accessory Compatibility List

Category	Product	Etc	ZUUW48GA1 [UUD1 U30]	
Central Controller	Simple	PQCSZ250S0	AC EZ	O
	AC Ez Touch	PACEZA000	AC Ez Touch	O
	AC Smart	PACS5A000	AC Smart 5	X
	ACP	PACP5A000	ACP 5	X
	AC Manager ²⁾	PACM5A000	AC Manager 5	X
Gateway	ODU PI485	PMNFP14A1	PI 485 Gateway	O
	Low Ambient Kit	PRVC2	From MULTI V 4 series	X
	AHU Comm. Kit	PAHCMR000	Return / Room Air Control	X
		PAHCMS000	Supply Air Control by DDC	X
	BACnet	PQNFB17C0	ACP BACnet	X
Lonworks	PLNWKB000	ACP Lonworks	X	
ETC	PDI	PPWRDB000	PDI Standard	X
		PQNUD1S40	PDI Premium	X
	ACS IO Module	PEXPMB000	-	X

Note

1. O: Possible, X: Impossible, -: Not applicable

2. * : Some advanced functions controlled by individual controller cannot be operated.

3. ²⁾ : ACP or AC Smart is needed.

4. Compatibility of individual controller(wireless/wired remote controller) could be found with function list on Indoor Unit's PDB.

5. If you need more detail, please refer to the **BECON** PDB or the manual of product.

(<http://partner.lge.com/global> : Home> Doc.Library> Product > Control(BECON))

2. List of Functions

■ 3 Phase Inverter - Synchro

◆ List of function

Category	Functions	ZUUW48LA1 [UUD3 U30]
Reliability	Defrost / Deicing	O
	High pressure switch	O
	Low pressure switch	X
	Phase protection	O
	Restart delay (3-minutes)	O
	Self diagnosis	O
	Soft start	O
Convenience	Test function	O
	Night Low Noise Operation	O
	Wiring Error Check	X
	Peak Control	X
	Mode Lock	X
	Forced Cooling Operation (Outdoor Unit)	O
Network function	Network solution(LGAP)	O
ODU Dry Contact		X

Note

1. O : Applied, X : Not applied

Accessory : Ordered and purchased separately the accessory package referring to the model name provided and install at field.

Accessory line-ups varies by region, so check your local catalogue or local sales material.

◆ Accessory Compatibility List

Category	Product	Etc	ZUUW48LA1 [UUD3 U30]	
Central Controller	Simple	PQCSZ250S0	AC EZ	O
	AC Ez Touch	PACEZA000	AC Ez Touch	O
	AC Smart	PACS5A000	AC Smart 5	X
	ACP	PACP5A000	ACP 5	X
	AC Manager ²⁾	PACM5A000	AC Manager 5	X
Gateway	ODU PI485	PMNFP14A1	PI 485 Gateway	O
	Low Ambient Kit	PRVC2	From MULTI V 4 series	X
	AHU Comm. Kit	PAHCMR000	Return / Room Air Control	X
		PAHCMS000	Supply Air Control by DDC	X
	BACnet	PQNFB17C0	ACP BACnet	X
Lonworks	PLNWKB000	ACP Lonworks	X	
ETC	PDI	PPWRDB000	PDI Standard	X
		PQNUD1S40	PDI Premium	X
	ACS IO Module	PEXPMB000	-	X

Note

1. O: Possible, X: Impossible, - : Not applicable

2. * : Some advanced functions controlled by individual controller cannot be operated.

3. ²⁾ : ACP or AC Smart is needed.

4. Compatibility of individual controller(wireless/wired remote controller) could be found with function list on Indoor Unit's PDB.

5. If you need more detail, please refer to the **BECON** PDB or the manual of product.

(<http://partner.lge.com/global> : Home> Doc.Library> Product > Control(BECON))

3. Combination Table

■ Possible combinations

	Possible combination of indoor units					
	Synchro					
	Duo		Trio		Quartet	
IDU : INDOOR UNIT ODU : OUTDOOR UNIT BD : BRANCH DISTRIBUTOR UNIT REMO : WIRED REMOTE CONTROLLER						
MODEL	Cassette	Duct	Cassette	Duct	Cassette	Duct
UUD1 / UUD3	CT18F NQ0 * 2	CM18F N10/N11 * 2	CT12F NR0 * 3	CL12F N50 * 3	CT12F NR0 * 4	CL12F N50 * 4
	CT24F NB0 * 2	CM24F N10 * 2	CT18F NQ0 * 3	CM18F N10/N11 * 3	-	-
	UT30F NB0 * 2	CM30F N10/N11 * 2	-	-	-	-
Branch Kit	PMUB11A		PMUB111A		PMUB1111A	

Note

- Possible indoor units: Single CAC indoor unit series
 - Dry contact & Zone control & Auto changeover is not available which is connected with synchro.
 - When using synchro operation
 - Do not use wireless remote controller
 - Use only one wired remote controller in the indoor units.
 - Some Central controllers and some functions of central controller can not be available with synchro operation.
- Branch kits are required for operating Synchro models.

4. Piping Length & Height

■ Synchro Operation

Install the branch pipe so that pipe length and difference between high and low will not exceed below Spec.

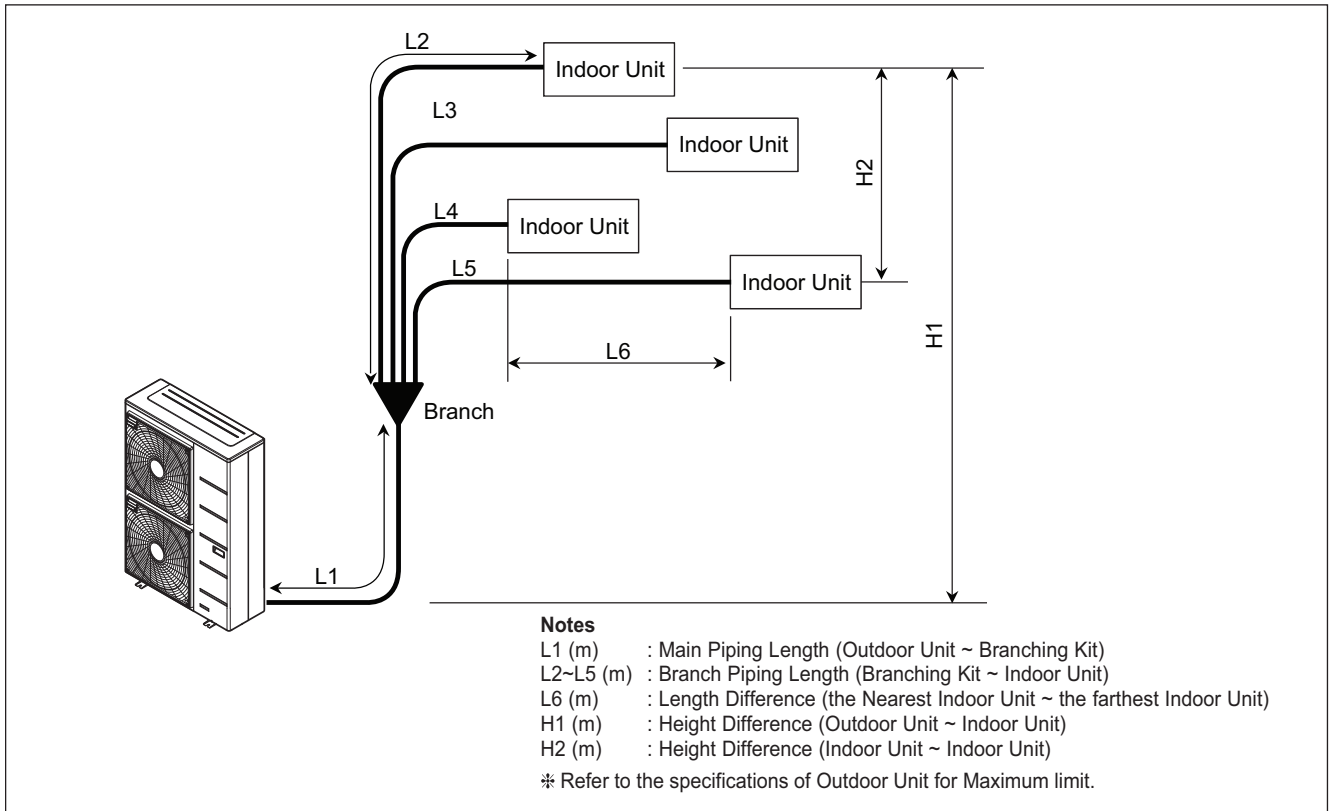

[Unit : m]

Pipe Length & Height	Spec(MAX.)
Total(L1+L2+L3+L4+L5)	80
Main Pipe(L1)	45
Branch Pipe (L2+L3+L4+L5) Each	40 15
Indoor-Outdoor (H1)	30
Indoor-Indoor (H2)	1
L6	10

- When installing the branch pipe, direction and angle of installation is not limited.
- Take care so that burrs and foreign material may not enter into the cutting surface when connecting.
- Connect remaining those by cutting or direct insertion to the diameter of pipe.

5. Simultaneous Operation Setting

Outdoor Unit PCB Setting Procedure

1. DIP_SW Setting
Set the DIP_SW as below Table (a)
 2. Auto Addressing Method
Addressing work assigns address to each indoor unit. When firstly installing product or replacing the indoor unit PCB.
Auto Addressing work should be done for simultaneous operation.
- Work procedure
 1. Set DIP_SW correctly.
 2. Turn on main power.
 3. Press the SW01M for about 3 seconds within 3 minutes After main power on.(b)

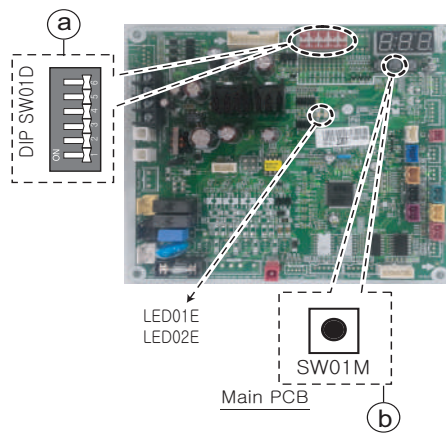

4. After step 3., the LED01E(red LED) and LED02E(green LED) rapidly flickers. When Addressing work is done, green LED is off, else LED(LED01E) stops flickering and lights continuously. Address of indoor unit is indicated on the wired remote control display window. (CH01, CH02, CH03,CH04)
5. Press button to turn on the indoor.
6. If you fail to perform the Addressing work, repeat step 2.~5.

Table DIP SW01D Setting

SW01D	Indoor Unit No.
	1(Single) : Default
	2(Duo)
	3(Trio)
	4(Quartet)

6. Piping Diagrams

■ "Synchro" Duo

ZUUW48GA1 [UUD1 U30], ZUUW48LA1 [UUD3 U30]

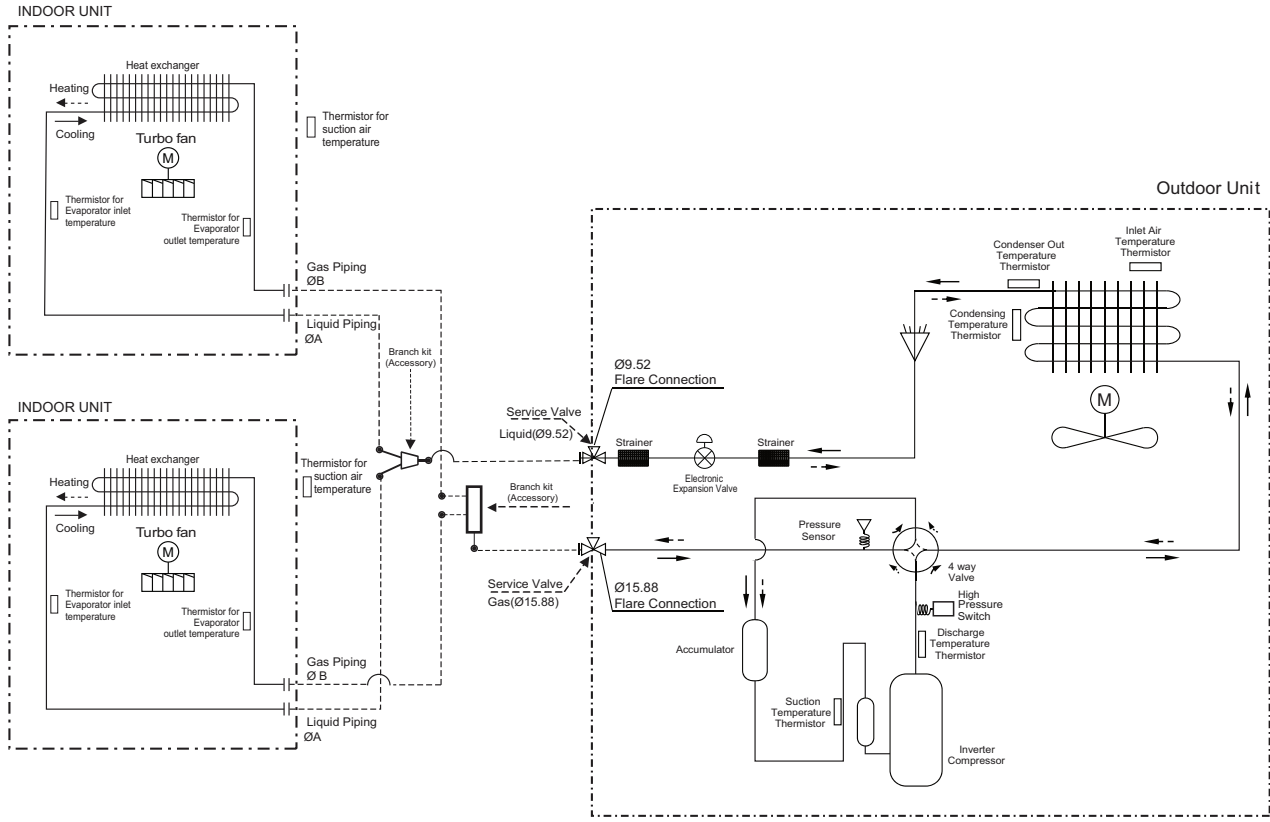

Indoor Unit (kW)	Liquid Pipe, A (mm)	Gas Pipe, B (mm)
5.0	6.35	12.7
7.1	9.52	15.88
8.0	9.52	15.88

Refrigerant Flow
 ← Cooling
 ← Heating

Note :
 1. The pipes between the indoor units and the branch kits must have same dimensions as indoor unit connections.

6. Piping Diagrams

■ "Synchro" Trio

ZUUW48GA1 [UUD1 U30], ZUUW48LA1 [UUD3 U30]

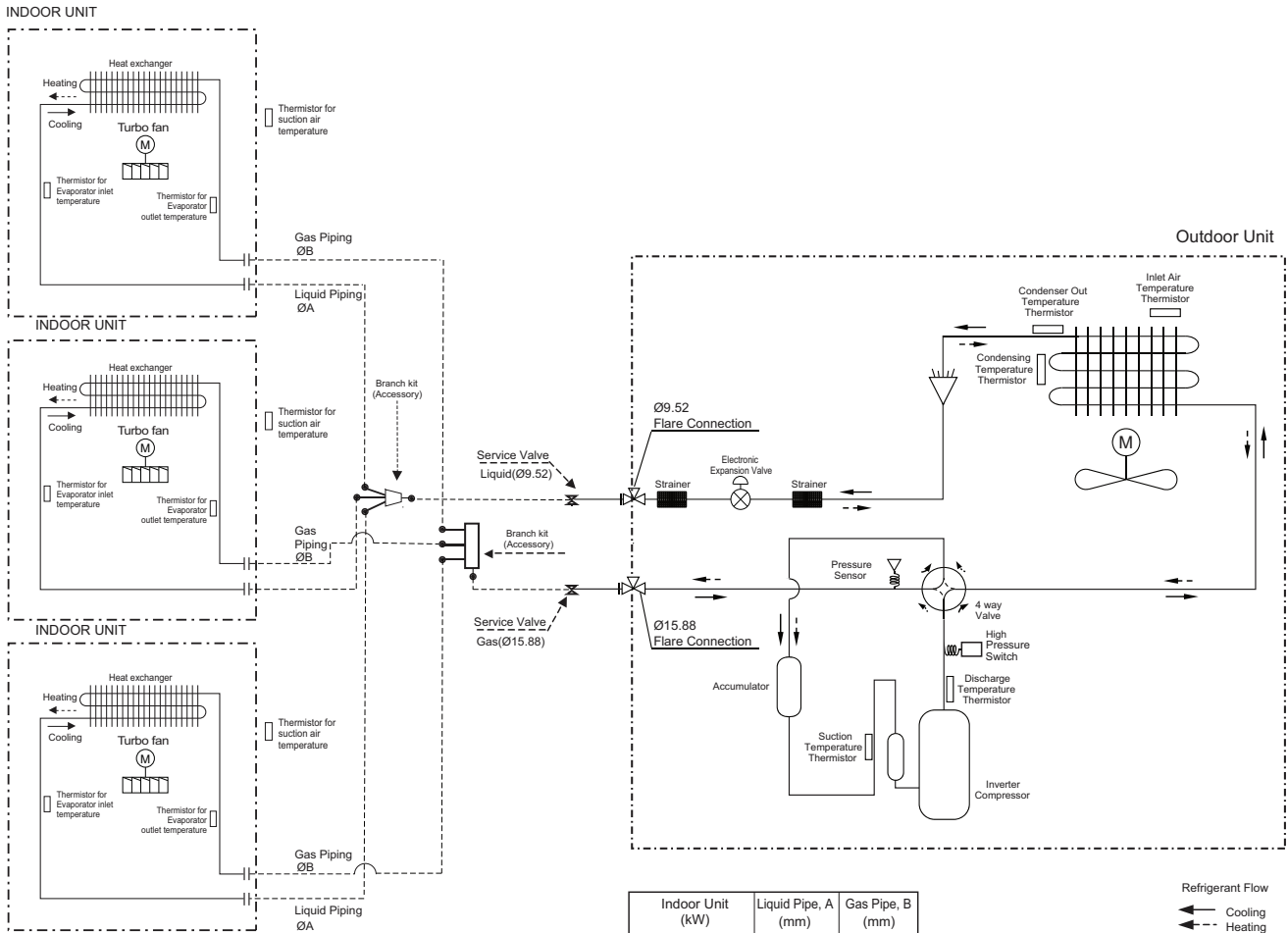

Indoor Unit (kW)	Liquid Pipe, A (mm)	Gas Pipe, B (mm)
3.5	6.35	9.52
5.0	6.35	12.7

Refrigerant Flow
 ← Cooling
 - - - Heating

Note :
 1. The pipes between the indoor units and the branch kits must have same dimensions as indoor unit connections.

6. Piping Diagrams

■ "Synchro" Quartet

ZUUW48GA1 [UUD1 U30], ZUUW48LA1 [UUD3 U30]

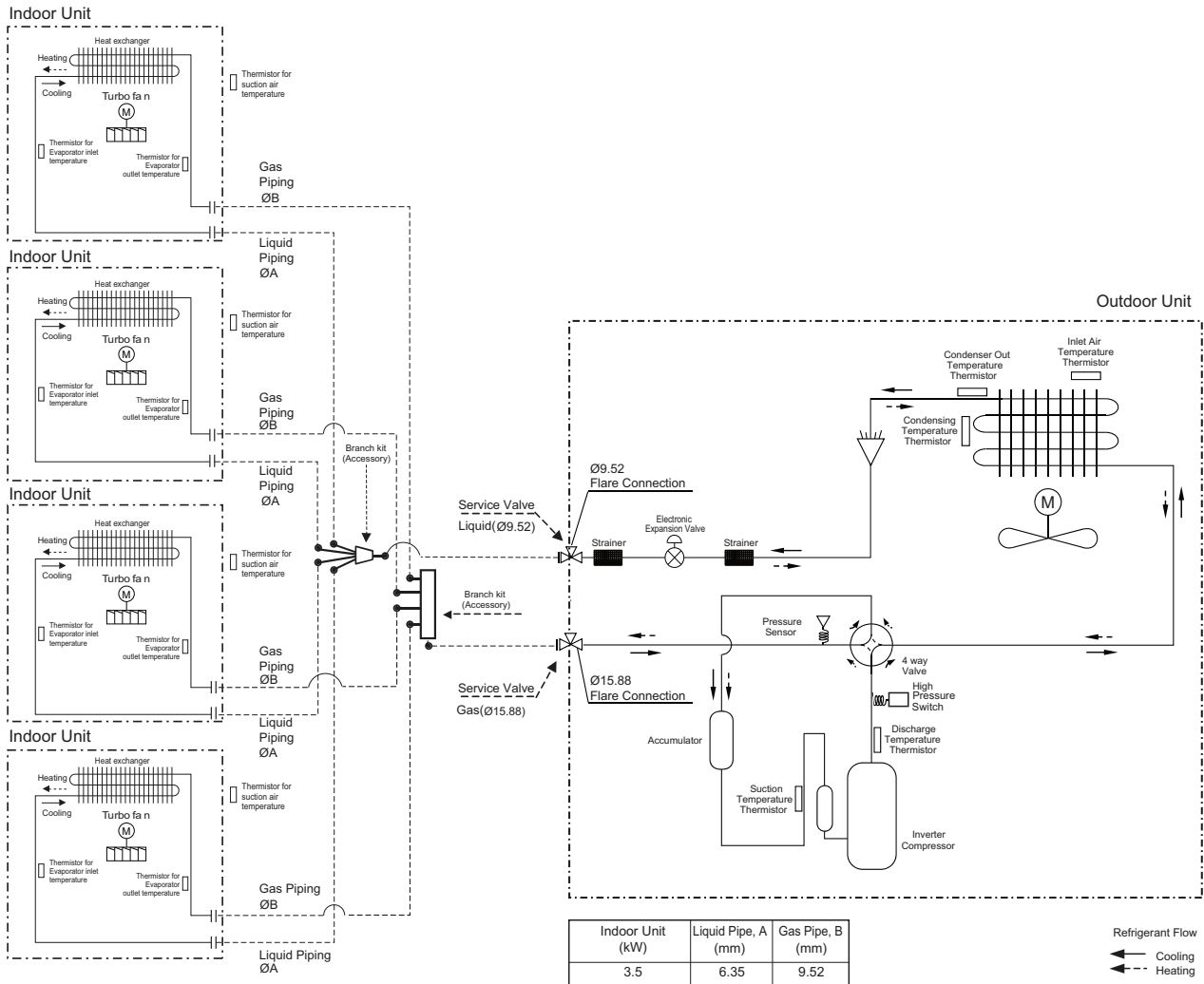

Note :
1. The pipes between the indoor units and the branch kits must have same dimensions as indoor unit connections.

7. Accessories

■ Optional accessories

Name	ModelNo.	Indoorclassification	CapacityRatio(%)
Branch Kit	PMUB11A	"Synchro" Duo	50:50(1:1)
	PMUB111A	"Synchro" Trio	33:33:33(1:1:1)
	PMUB1111A	"Synchro" Quartet	25:25:25:25(1:1:1:1)

SINGLE

Installation of Outdoor Units

- 1. Alternative Refrigerant R32**
- 2. Select the Best Location**
- 3. Installation Space**
- 4. Installation of Outdoor Unit**
- 5. Refrigerant piping system**
- 6. Installation guide at the seaside**
- 7. Seasonal wind and caution in winter**

1. Alternative Refrigerant R32

The refrigerant R32 has the higher efficiency and more friendly for environment in comparison with R410A. It has a lower GWP (Global Warming Potential) value, and higher efficiency than R410A. The Ozone Depletion Potential (ODP) of R32 is 0, and Global Warming Potential(GWP) is 675.

Refrigerant piping consists of copper/steel pipes, joints, and other fittings. All components must be selected and installed in conformity with the standards pertaining to the Refrigeration Safety Regulation. Same piping as for R410A can be used.

WARNING

- This product contains fluorinated greenhouse gases (Refrigerant type : R32). Do NOT emit refrigerant gases into the atmosphere.
 - The refrigerant R32 is Slightly Flammable gas. But it does not leak normally. If the refrigerant leaks in the room and contact with burning energy, it may cause fire, or a harmful gas.
 - If there are some leak, turn off any combustible devices, ventilate the room, and contact the dealer from which you purchased the unit. Do not use the unit until the refrigerant leaked is repaired.
 - Only use R32 as refrigerant. Other substances may cause explosions and accidents.
-

CAUTION

- The wall thickness of the piping should comply with the relevant local and national regulations for the designed pressure.
 - For high-pressure refrigerant, any unapproved pipe must not be used.
 - Do not heat pipes more than necessary to prevent them from softening.
-

1. Alternative Refrigerant R32

Minimum Floor Area for Installation

- The unit should be installed, operated and stored in a room with a floor area larger than the minimum area. Use the graph of table to determine the minimum area.
- Pipe-work shall be protected from physical damage and shall not be installed in an unventilated space, if that space is smaller than minimum area for installation.

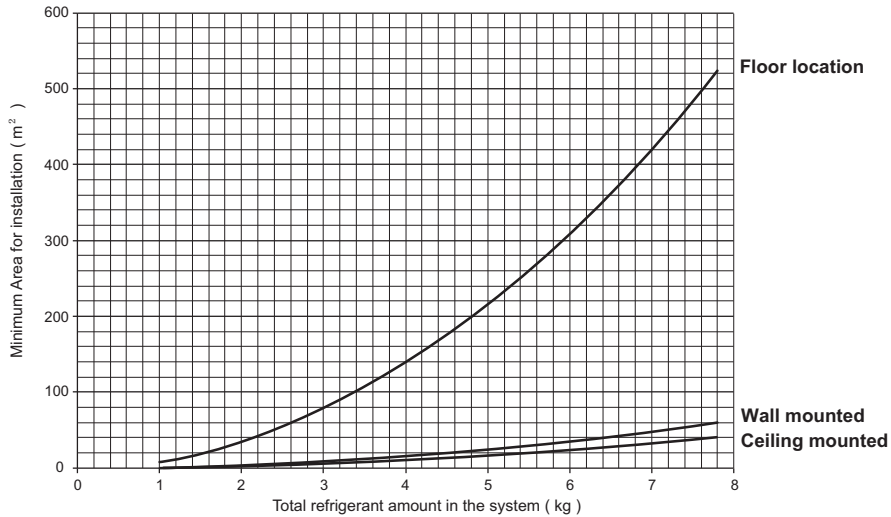

– Total refrigerant amount in the system = factory refrigerant charge + additional refrigerant amount

Refrigerant Amount (kg)	Minimum Area (m ²)		
	Floor location	Wall mounted	Ceiling Mounted
1.0	8.58	0.95	0.64
1.224	12.90	1.43	0.956
1.4	16.82	1.87	1.25
1.6	21.97	2.44	1.63
1.8	27.80	3.09	2.07
2.0	34.32	3.81	2.55
2.2	41.53	4.61	3.09
2.4	49.42	5.49	3.68
2.6	58.00	6.44	4.31
2.8	67.27	7.47	5.00
3.0	77.22	8.58	5.74
3.2	87.86	9.76	6.54
3.4	99.19	11.02	7.38
3.6	111.20	12.36	8.27
3.8	123.90	13.77	9.22
4.0	137.29	15.25	10.21
4.2	151.36	16.82	11.26
4.4	166.12	18.46	12.36
4.6	181.56	20.17	13.50
4.8	197.70	21.97	14.70
5.0	214.51	23.83	15.96
5.2	232.02	25.78	17.26
5.4	250.21	27.80	18.61
5.6	269.09	29.90	20.01
5.8	288.65	32.07	21.47
6.0	308.90	34.32	22.98
6.2	329.84	36.65	24.53
6.4	351.46	39.05	26.14
6.6	373.77	41.53	27.80
6.8	396.76	44.08	29.51
7.0	420.45	46.72	31.27
7.2	444.81	49.42	33.09
7.4	469.87	52.21	34.95
7.6	495.61	55.07	36.86
7.8	522.04	58.00	38.83

2. Select the Best Location

Select space for installing outdoor unit, which will meet the following conditions:

- No direct thermal radiation from other heat sources
- No possibility of annoying neighbors by noise from unit
- No exposition to strong wind
- With strength which bears weight of unit
- Note that drain flows out of unit when heating (Heat pump model)
- With space for air passage and service work shown next
- Because of the possibility of fire, do not install unit to the space where generation, inflow, stagnation, and leakage of combustible gas is expected.
- Avoid unit installation in a place where acidic solution and spray (sulfur) are often used.
- Do not use unit under any special environment where oil, steam and sulfuric gas exist.
- It is recommended to fence round the outdoor unit in order to prevent any person or animal from accessing the outdoor unit.
- If installation site is area of heavy snowfall, then the following directions should be observed.
 - Make the foundation as high as possible.
 - Fit a snow protection hood.
- Select installation location considering following conditions to avoid bad condition when additionally performing defrost operation. (Heat pump model)
 1. Install the outdoor unit at a place well ventilated and having a lot of sunshine in case of installing the product at a place with a high humidity in winter (near beach, coast, lake, etc).
(Ex) Rooftop where sunshine always shines.
 2. Performance of heating will be reduced and pre-heat time of the indoor unit may be lengthened in case of installing the outdoor unit in winter at following location:
 - 1) Shade position with a narrow space
 - 2) Location with much moisture in neighboring floor.
 - 3) Location with much humidity around.
 - 4) Location where liquid gathers since the floor is not even.

3. Installation Space

3.1 Clearance around outdoor units

- Ensure that the space around the back is or more more than 300 mm on the opposite to the PCB side and secure 600 mm space near the compressor and PCB side of the air conditioner for service.

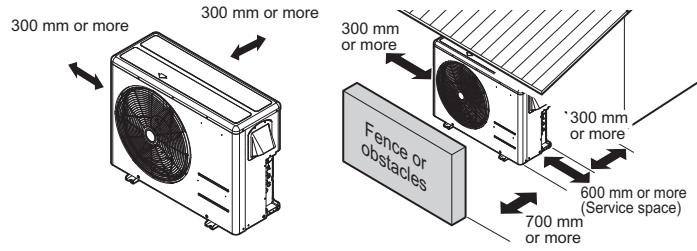

※ Outdoor unit is representative. Actual appearance of outdoor unit may be different but clearances will stay the same.

- Install the unit so that its discharge port faces to the wall of the building. Keep a distance 500mm or more between the unit and the wall surface.
- Supposing the wind direction during the operation season of the air conditioner, install the unit so that the discharge port is set at right angle to the wind direction.

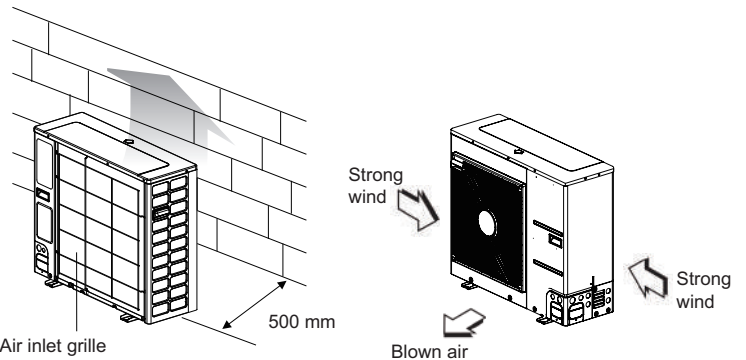

Turn the air outlet side toward the building's wall, fence or windbreak screen.

Set the outlet side at a right angle to the direction of the wind.

※ Outdoor unit is representative. Actual appearance of outdoor unit may be different but clearances will stay the same.

3. Installation Space

■ Where there is an obstacle on the air intake side:

◆ No obstacle above

[Unit : mm(inch)]

- Obstacle on the suction side only

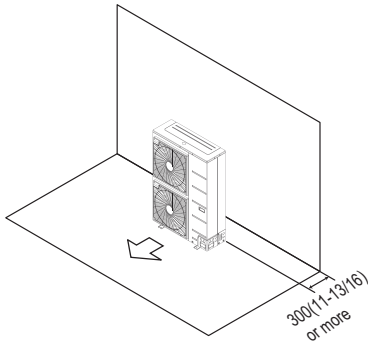

- Obstacle on the both sides

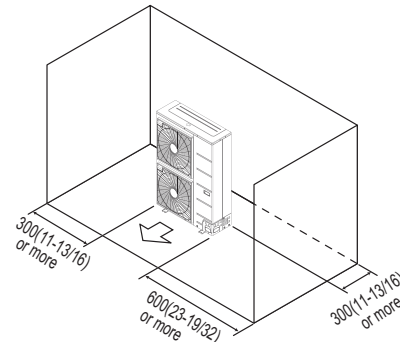

◆ Obstacle above, too

[Unit : mm(inch)]

- Obstacle on the air intake side, too

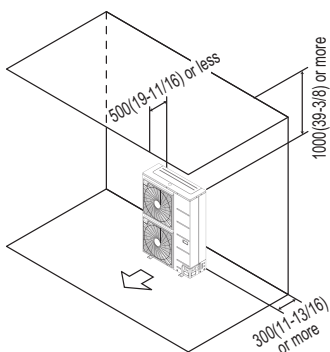

- Obstacle on the air intake side, and both sides

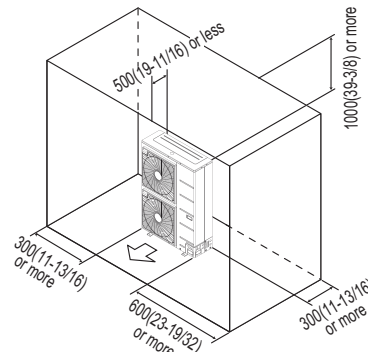

■ Where there is an obstacle on the discharge side:

[Unit : mm(inch)]

- No obstacle above

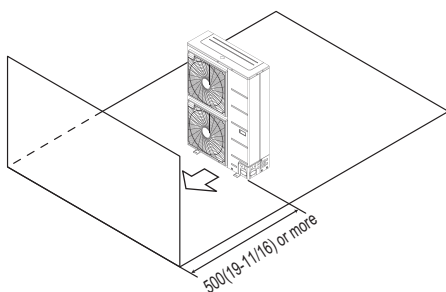

- Obstacle above, too

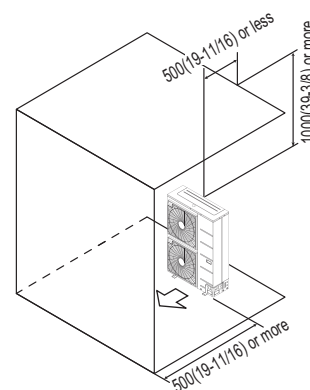

3. Installation Space

■ Where there are obstacles on both suction and discharge sides:

◆ Where the obstacles on the discharge side is higher than the unit:

[Unit : mm(inch)]

- No obstacle above

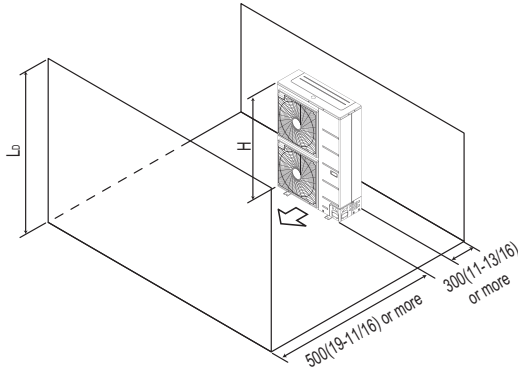

- Obstacle above, too

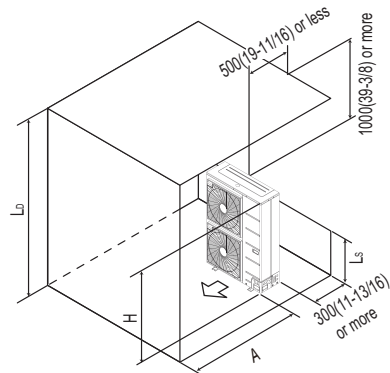

The relations between H, A and L are as follows:

	L_s	A[mm(inch)]
$L_s \leq H$	$0 < L_s \leq 1/2H$	750(29 1/32)
	$1/2H < L_s$	1 000(39 3/8)

Close the bottom of the installation frame to prevent the discharged air from being bypassed.

◆ Where the obstacles on the discharge side is lower than the unit:

[Unit : mm(inch)]

- No obstacle above

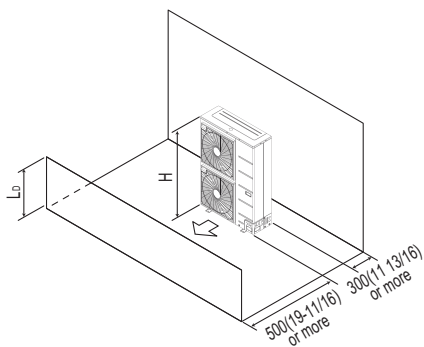

- Obstacle above, too
'L_D' should be lower than 'H'.
Close the bottom of the installation frame to prevent the discharged air from being bypassed.

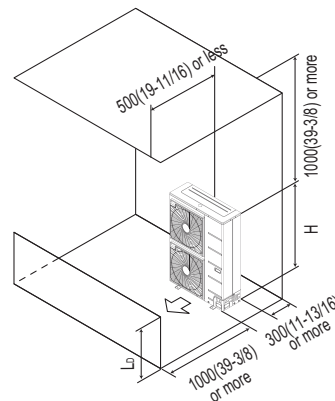

3. Installation Space

Series installation

[Unit : mm(inch)]

• One row of stand alone installation

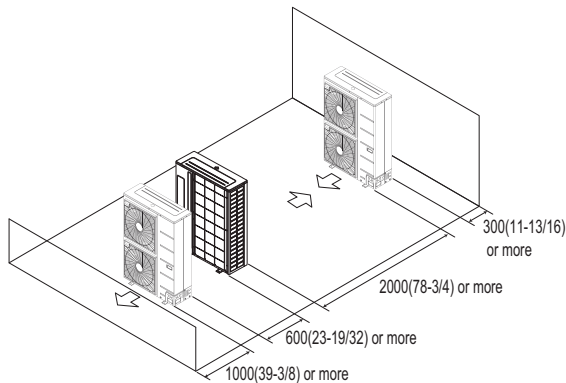

• Rows of collective installation (2 or more)

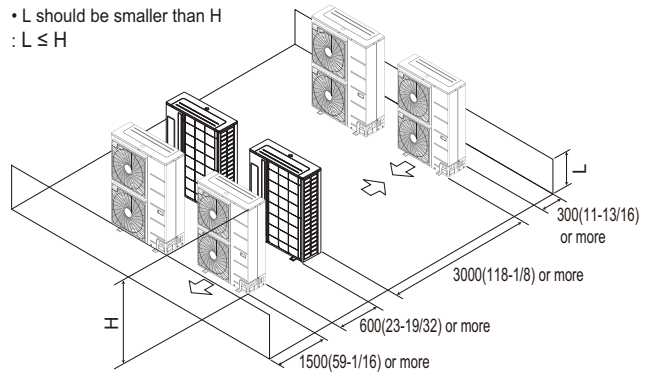

3.2 Air guide work

In case of out door unit is located outdoor cabin of apartment or flats, then the efficiency can drop and system pressure increases thus finally damaging the compressor or other components in the system by heat short circuit.

[Example]

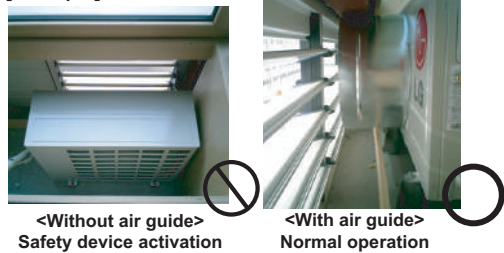

3.3 Lightning safety zone

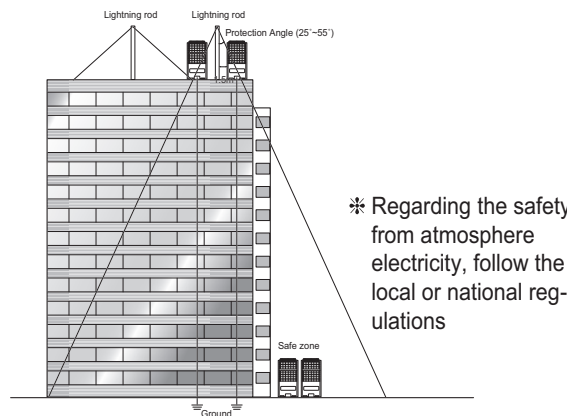

1. To protect outdoor unit from lightning, it should be placed within lightning safety zone.

◆ Safety zone

Building Height [m]	20	30	45	60
Protection Angle [°]	55	45	35	25

2. Power cable and communication cable should be 1.5m away from lightning rod.
3. High resistance grounded system should be performed against induced lightning or indirect stroke.
4. If the building has no lightning protection, outdoor may be damage from lightning. This should be informed to customer or building owner in advance.

4. Installation of Outdoor Unit

4.1 Foundation for Installation

- Fix the unit tightly with bolts as shown below so that unit will not fall down due to earthquake or gust.
- Use the H-beam support as a base support.
- Noise and vibration may occur from the floor or wall since vibration is transferred through the installation part depending on installation status. Thus, use anti-vibration materials (cushion pad) fully (The base pad shall be more than 200mm).

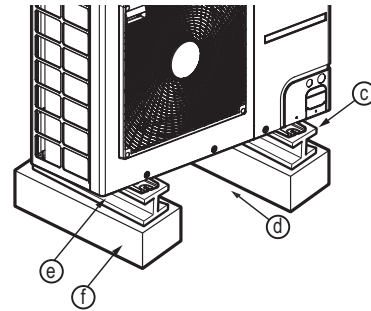
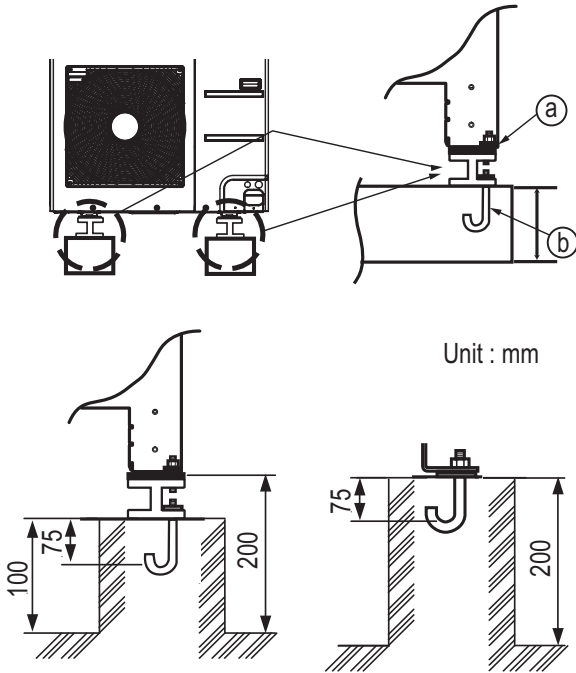

- (a) The corner part must be fixed firmly. Otherwise, the support for the installation may be bent.
 - (b) Get and use M10 Anchor bolt.
 - (c) Put Cushion Pad between the outdoor unit and ground support for the vibration protection in wide area.
 - (d) Space for pipes and wiring (Pipes and wirings for bottom side)
 - (e) H-beam support
 - (f) Concrete support
- * Outdoor unit is representative. Actual appearance of outdoor unit may be different but clearances will stay the same.

⚠ WARNING

- Install where it can sufficiently support the weight of the outdoor unit.
If the support strength is not enough, the outdoor unit may drop and hurt people.
- Install where the outdoor unit may not fall in strong wind or earthquake.
If there is a fault in the supporting conditions, the outdoor unit may fall and hurt people.
- Please take extra cautions on the supporting strength of the ground, water outlet treatment (treatment of the water flowing out of the outdoor unit in operation) of heat pump unit, and the passages of the pipe and wiring, when making the ground support.
- Do not use tube or pipe for water outlet in the Base pan. Use drainage instead for water outlet.
The tube or pipe may freeze and the water may not be drained. (Heat pump model)

⚠ WARNING

- Be sure to remove the Pallet (Wood Support) of the bottom side of the outdoor unit Base Pan before fixing the bolt. It may cause the unstable state of the outdoor settlement, and may cause freezing of the heat exchanger resulting in abnormal operations.
- Be sure to remove the Pallet (Wood Support) of the bottom side of the outdoor unit before welding. Not removing Pallet (Wood Support) causes hazard of fire during welding.

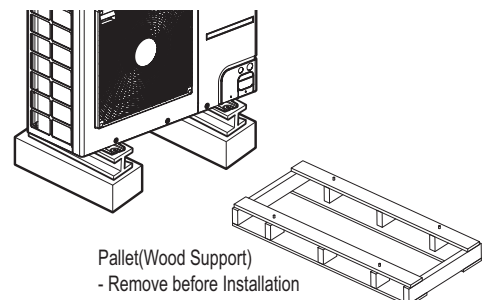

4. Installation of Outdoor Unit

4.2 Settlement of the outdoor unit

- Anchor the outdoor unit with a bolt and nut tightly and horizontally on a concrete or rigid mount.
- When installing on the wall, roof or rooftop, anchor the mounting base securely with a nail or wire assuming the influence of wind and earthquake.
- In the case when the vibration of the unit is conveyed to the house, secure the unit with an anti-vibration rubber.

◆ Bolt construction work

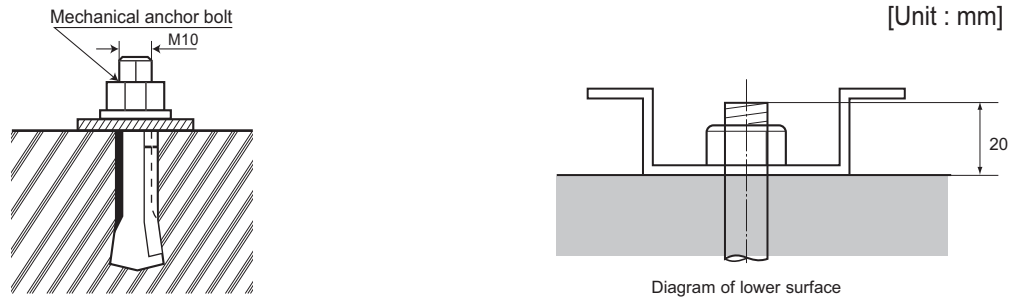

◆ Settlement draw of outdoor units

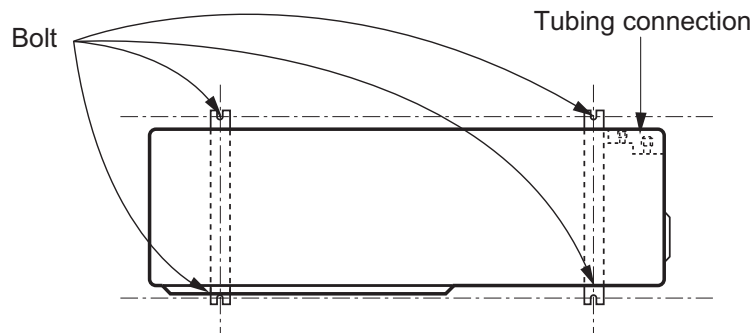

⚠ CAUTION

- The ingredients of foundation : Cement : Sand : Gravel for the concrete should 1 : 2 : 4 ratio
- The foundation surface should be finished with mortar.
- The edges of foundation should be rounded.
- A drain passage should be made around the foundation to thoroughly drain water away from the equipment installation area. (Heat pump model)
- If installing the outdoor units on the roof, the roof's strength have to be checked.
- Care should be taken for weather - proofing
- Blocking all gaps of outdoor unit, for passing piping and wiring, using sealing material (Field supply)
(Animals and bugs might enter in the machine.)

5. Refrigerant piping system

5.1 Piping System between outdoor unit / indoor unit

■ Single type

⚠ CAUTION

- Please check the product type. Piping installation and refrigerant charge varies depending on the type of product.
For more information, please refer to the installation manual.

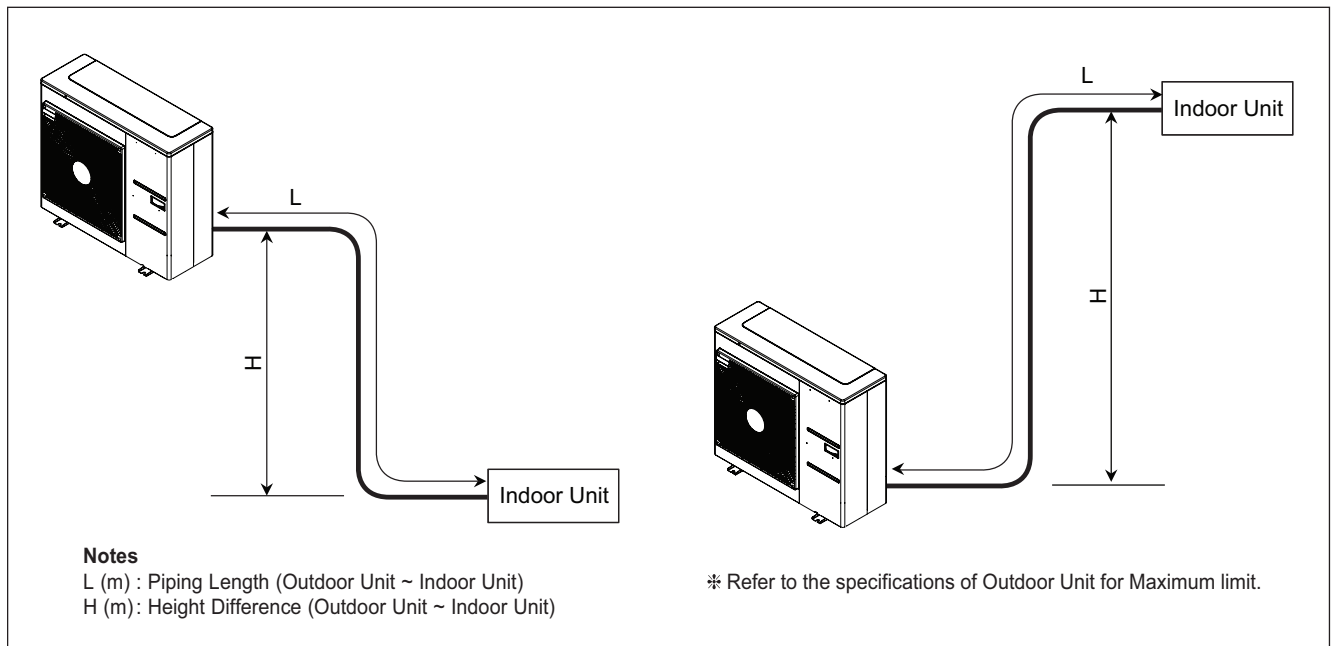

◆ Refrigerant additional charge calculation method

$$\text{Additional Refrigerant} = (L - A) \times a$$

L (m) : Installed Piping Length (Outdoor Unit ~ Indoor Unit)

A (m) : Charge-less piping length

a (g/m) : Additional charging volume

* Refer to the specifications for detail information of A, a.

* If total additional charge value after calculation comes out to be negative, then do not consider additional charge.

⚠ CAUTION

- Capacity is based on standard length and maximum allowance length is on the basis of reliability.
- Improper refrigerant charge may result in abnormal cycle.

5. Refrigerant piping system

■ Single type - Synchro

⚠ CAUTION

- Please check the product type. Piping installation and refrigerant charge varies depending on the type of product.
For more information, please refer to the installation manual.

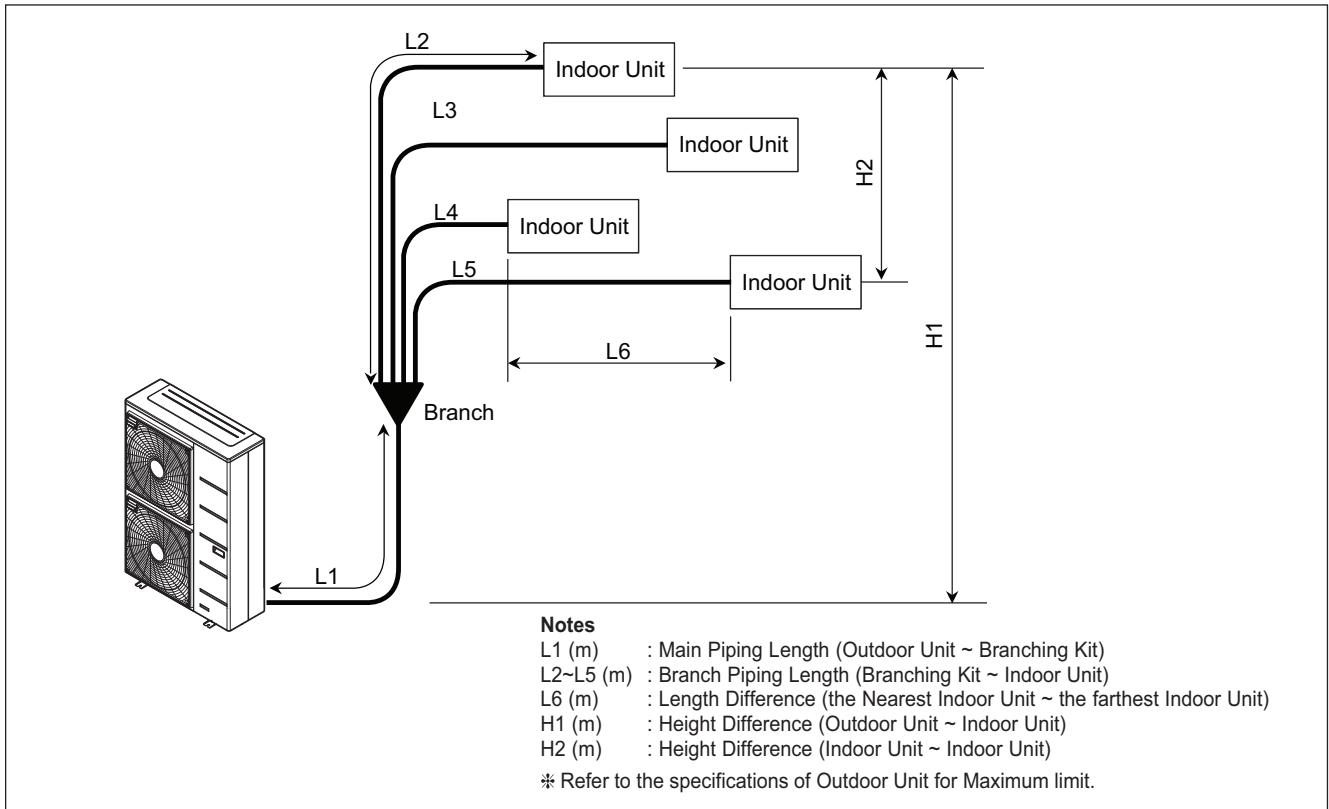

- When installing the branch pipe, direction and angle of installation is not limited.
- Take care so that burrs and foreign material may not enter into the cutting surface when connecting.
- Connect remaining those by cutting or direct insertion to the diameter of pipe.

◆ Refrigerant additional charge calculation method

Liquid Pipe Diameter (mm)	b (g/m)
Ø 6.35	35
Ø 9.52	40

Additional Refrigerant = (L1 - A) x a + (L2 + L3 + L4 + L5) x b

L1 (m) : Installed Branch Piping Length (Outdoor Unit ~ Branching Kit)

L2~L5 (m) : Installed Branch Piping Length (Branching Kit ~ Indoor Unit)

a (g/m) : Additional charging volume for Main Pipe (Outdoor Unit ~ Branching Kit)

b (g/m) : Additional charging volume for Branch Pipe (Branching Kit ~ Indoor Unit)

* Refer to the specifications for detail information of A, a.

* If total additional charge value after calculation comes out to be negative, then do not consider additional charge.

⚠ CAUTION

- Capacity is based on standard length and maximum allowance length is on the basis of reliability.
- Improper refrigerant charge may result in abnormal cycle.

6. Installation guide at the seaside

⚠ CAUTION

1. Air conditioners should not be installed in areas where corrosive gases, such as acid or alkaline gas, are produced.
2. Do not install the product where it could be exposed to sea wind (salty wind) directly. It can result corrosion on the product. Corrosion, particularly on the condenser and evaporator fins, could cause product malfunction or inefficient performance.
3. If outdoor unit is installed close to the seaside, it should avoid direct exposure to the sea wind. Otherwise it needs additional anticorrosion treatment on the heat exchanger.

■ Selecting the location(Outdoor Unit)

1. If the outdoor unit is to be installed close to the seaside, direct exposure to the sea wind should be avoided. Install the outdoor unit on the opposite side of the sea wind direction.

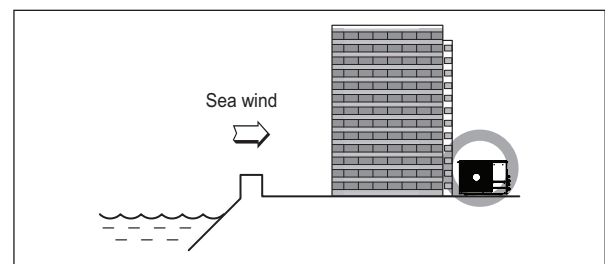
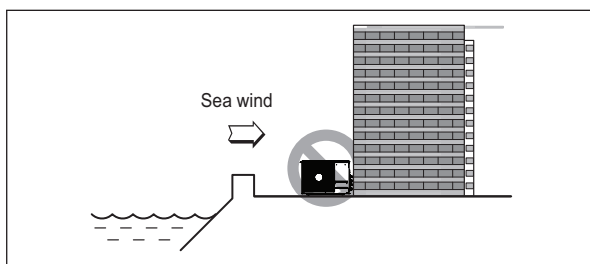

2. In case, to install the outdoor unit on the seaside, set up a windbreak not to be exposed to the sea wind.

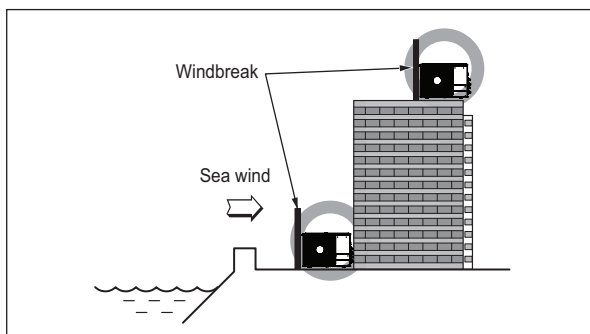

- It should be strong enough like concrete to prevent the sea wind from the sea.
- The height and width should be more than 150% of the outdoor unit.
- It should be kept more than 70 cm of space between outdoor unit and the windbreak for easy air flow.

3. Select a well-drained place.

Note

Periodic (more than once/year) cleaning of the dust or salt particles stuck on the heat exchanger by using water

7. Seasonal wind and cautions in winter

- Sufficient measures are required in a snow area or severe cold area in winter so that product can be operated well.
- Get ready for seasonal wind or snow in winter even in other areas.
- Install a suction and discharge duct not to let in snow or rain.
- Install the outdoor unit not to come in contact with snow directly. If snow piles up and freezes on the air suction hole, the system may malfunction. If it is installed at snowy area, attach the hood to the system.
- Install the outdoor unit at the higher installation console by 50cm than the average snowfall (annual average snowfall) if it is installed at the area with much snowfall.
- Where snow accumulated on the upper part of the Outdoor Unit by more than 10cm, always remove snow for operation.

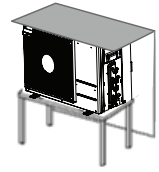

Note

1. The height of H frame must be more than 2 times the snowfall and its width shall not exceed the width of the product. (If width of the frame is wider than that of the product, snow may accumulate)
 2. Don't install the suction hole and discharge hole of the Outdoor Unit facing the seasonal wind.
-



Air Solution

LG Electronics Inc, 128, Yeoui-daero,
Yeongdeungpo-gu, Seoul, Korea
(07336)
<http://partner.lge.com>

Copyright © 2020-2025 LG Electronics Inc.
All Rights Reserved.
Printed in Korea May / 2025

The air conditioners manufactured by LG have received ISO9001 certificate for quality assurance and ISO14001 certificate for environmental management system.
The specifications, designs, and information in this brochure are subject to change without notice.