

LG

ERV

Energy Recovery Ventilator
0CEE0-01R(Replaces 0CEE0-01Q)

TOTAL HVAC SOLUTION PROVIDER

ENGINEERING PRODUCT DATA BOOK

ERV

Energy Recovery Ventilator

General information

Product Data

ERV

Energy Recovery Ventilator

General information

1.Models List

2.Nomenclature

3.Features & Benefits

1. Models List

Nominal Capacity CMH (CFM)	Model Name	Power Supply (Phase, V , Hz)
250 (147)	LZ-H025GBA4	1 Ø, 220 - 240 V, 50 HZ
350 (206)	LZ-H035GBA5	
500 (294)	LZ-H050GBA5	
800 (471)	LZ-H080GBA5	
1,000 (589)	LZ-H100GBA5	
1,500 (883)	LZ-H150GBA5	
2,000 (1,177)	LZ-H200GBA5	

2. Nomenclature

Model Name	LZ	H	050	G	B	A	5
No.	1	2	3	4	5	6	7

No.	Signification
1	Indicates that this is LG's ventilation system
2	Heat Exchange Type H : Total Heat Recovery
3	Capacity EX) 080 : 800 CMH, 100 : 1,000 CMH
4	Electric standard (Volts, Freq., Phase) G : 220V-240V, 50Hz, 1Ø / 220V, 60Hz, 1Ø
5	Model Type B : Ceiling Concealed Type
6	Function A : Basic
7	Development Sequence

3. Features & Benefits

■ **The LG heat recovery ventilation system, ERV , is the solution for improving your indoor air quality.**

Ventilation is a process by which one can exchange indoor air to outdoor air in order to improve the air quality and to maintain environmental temperature conditions.

With today's concern for a healthy indoor environment, **ERV** is an integral component of HVAC system. Using **ERV** in the HVAC system allows contaminants to be removed quickly and effectively from the air conditioned space. A balance is thus achieved between indoor and outdoor ambients, enabling the cooling or heating load on the air conditioning system to be reduced significantly.

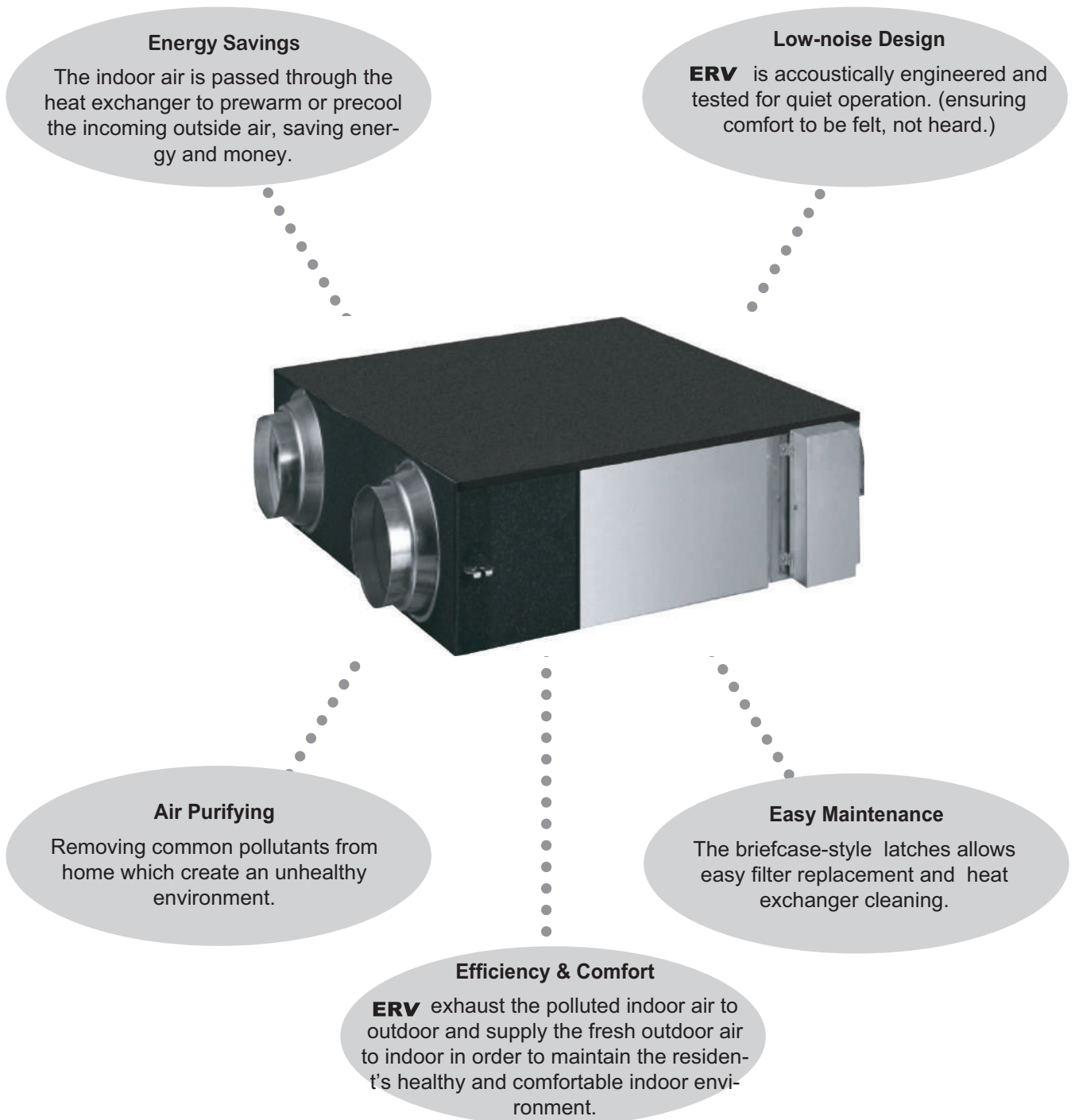

3. Features & Benefits

Healthy and Fresh Indoor Environmental Maintenance :

Case of the window ventilation

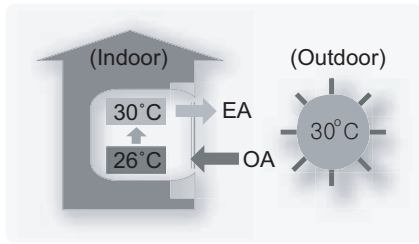

In order to ventilate the indoor air is to open the window in summer. While opening the window, the conditioned indoor air goes out. Indoor air has to be cooling again.

Case of Enthalpy heat exchange ventilation

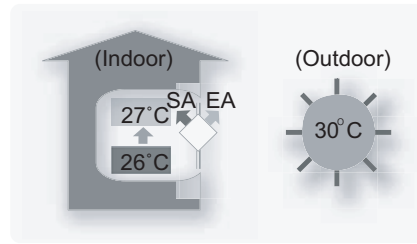

When using the enthalpy heat exchanger, it maintains the temperature and humidity of the indoor and changes the polluted indoor air to the fresh outdoor air.

25% Saving Energy

- Comparing to Enthalpy heat exchange ventilation with the window ventilation, Enthalpy heat exchange enables to economize a electric bill. It also helps the environmental protection due to saving energy.

Enthalpy Heat and Sensible Heat Exchangers Comparisons :

- Enthalpy Heat Exchanger**
= Temperature heat (temperatures) + Latent heat (humidity)

- Sensible Heat Exchanger**
= Temperature heat (temperatures)

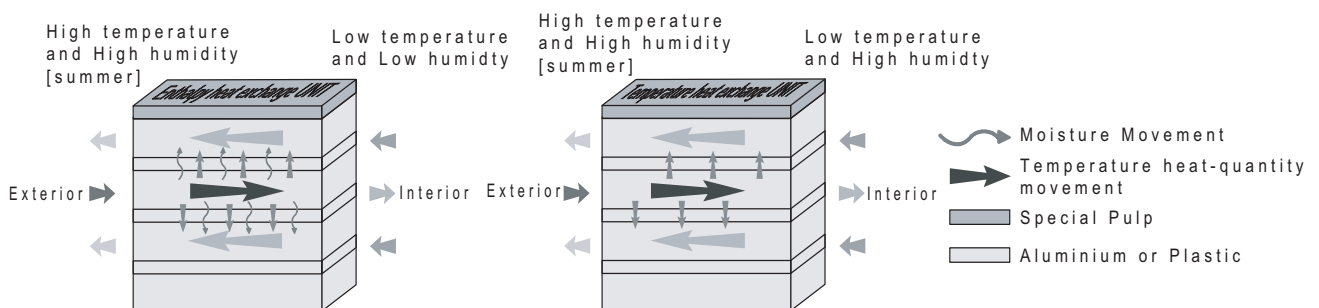

- The Enthalpy Heat Exchanger consists of Mechanism which is exchanged to the temperature heat (temperatures) as well as the latent heat (moisture heat capacity). When it calculates at the electric heat frequency quantity, it has an energy recovery effect above 3 times than the temperature heat.

3. Features & Benefits

■ Reclaimed Energy Comparisons in Psychrometric Chart :

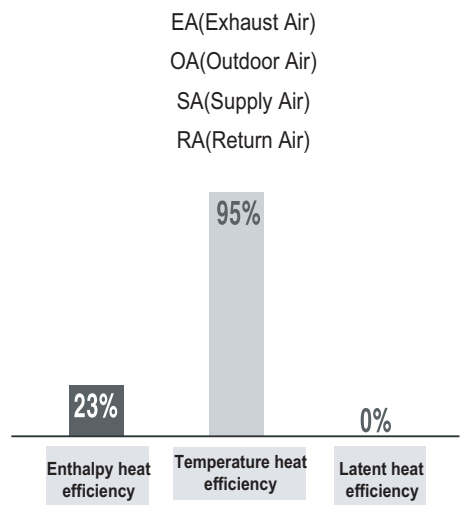
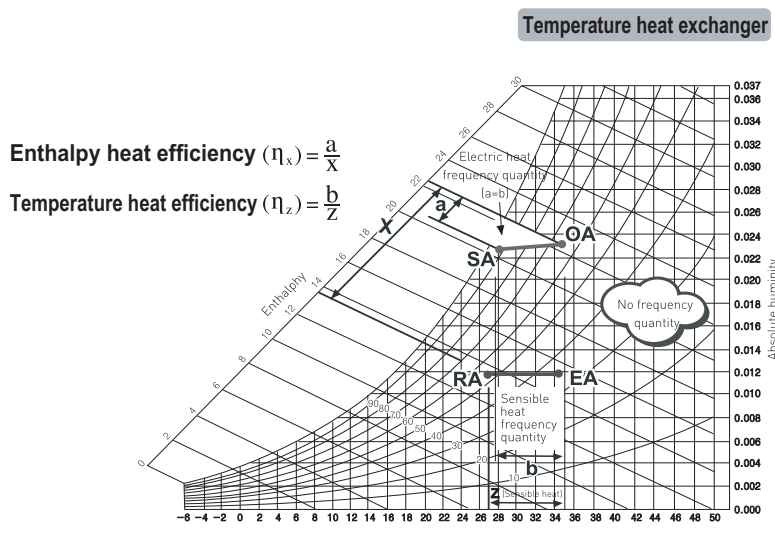
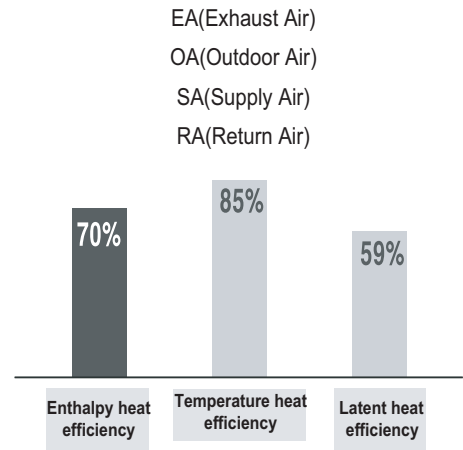
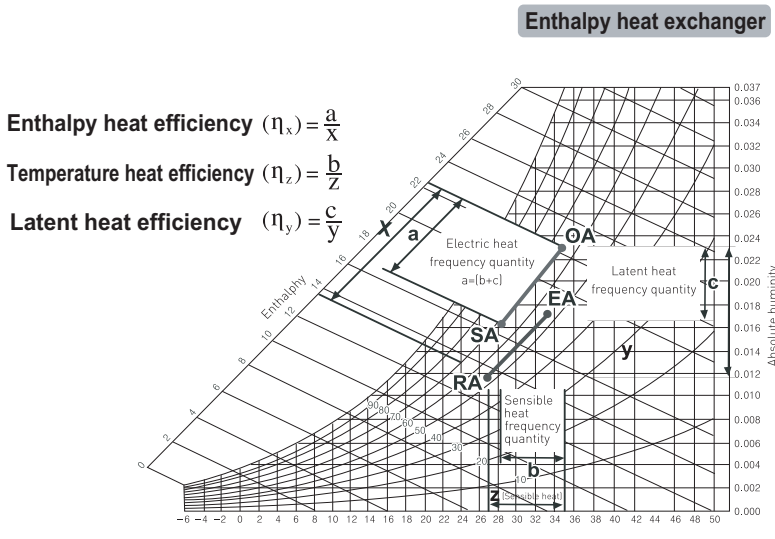

- Like appearing from the picture of the case only of the temperature heat exchange, the efficiency is high. But when it calculates at enthalpy heat frequency quantity, it has a difference above 3 times.

■ Zero Standby Power Consumption :

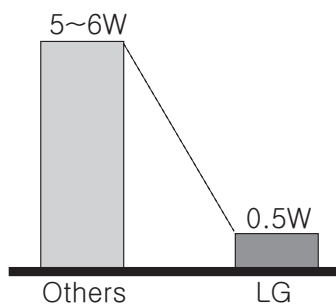

- Due to SMPS (Switching Modulation Power Supply) technology, there is almost zero power consumption in the standby mode. It saves energy and cost.

3. Features & Benefits

High Efficiency Heat Exchanger :

- Cross flow heat exchanger ensure no mixing of the stale air with the fresh air. Efficiency and comfort is ensured by the high-efficiency energy recovery central core which recovers energy from the indoor air and transfers it to the fresh incoming air without mixing airstreams. The heat exchanger also helps to remove unwanted humidity from air inside your home during winter, and removes the humidity from the out-side air before it enters your home in the summer.

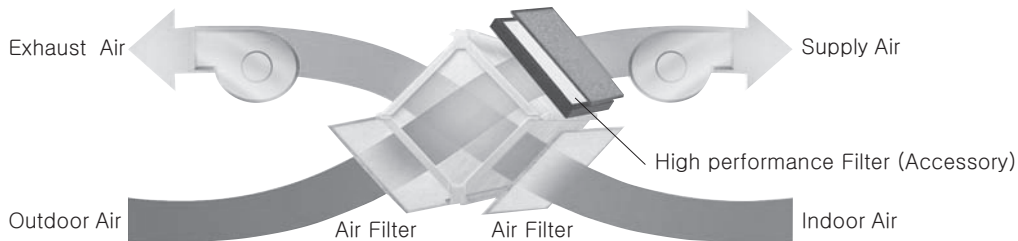

EzTuning : (External Static Pressure Control)

- Individual air volume control (supply & Exhaust)
Generally, when External Static Pressure increases air volume decreases. But by controlling the RPM of BLDC Motor E.S.P is changeable. E.S.P. control provides required constant air volume irrespective of E.S.P. change. Desired E.S.P. can also be set through LCD wired remote. Setting of the desired E.S.P. gives required combination of ESP and airflow.
So, air volume is kept constant for various duct work system. All ERV units feature BLDC Motor.

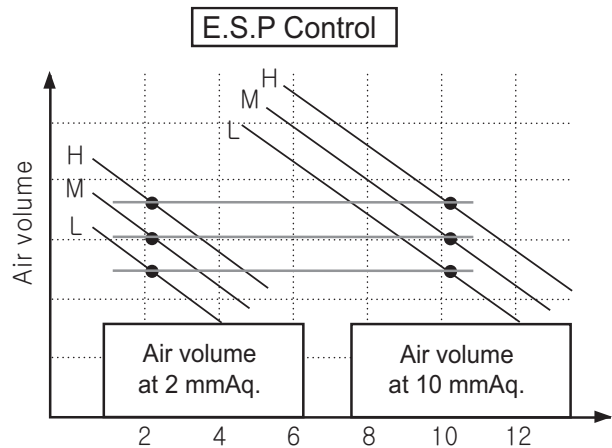

3. Features & Benefits

■ Auto Operation :

- Automatically switches the ventilation mode (Total Heat Exchange Mode/Bypass Mode) according to the operating status of the air conditioner.

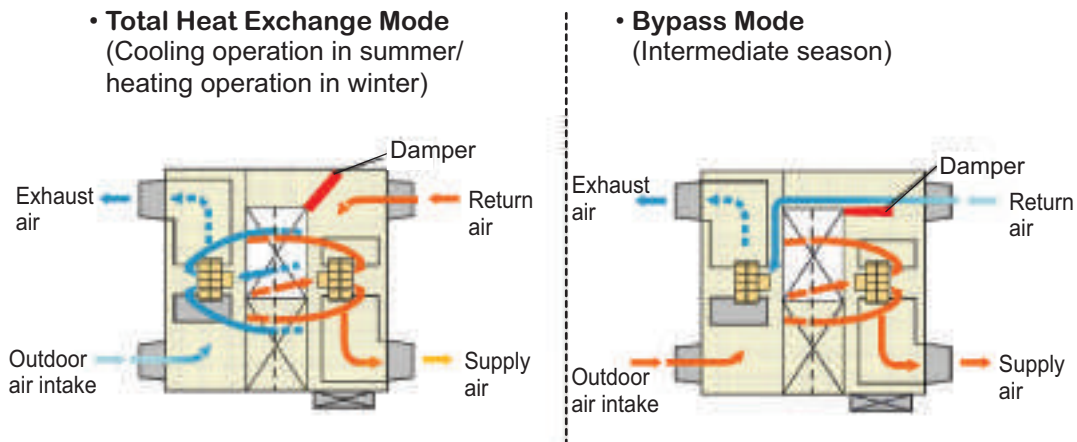

■ Flexibility of Installation :

- Possibility of opposite installation of up and lower part
Case of the installation of 2 units, generally it is necessary to two maintenance spaces. If it is installed opposite one unit of up and lower part, it is necessary to one maintenance space.
(1,500 / 2,000 CMH models are not available)

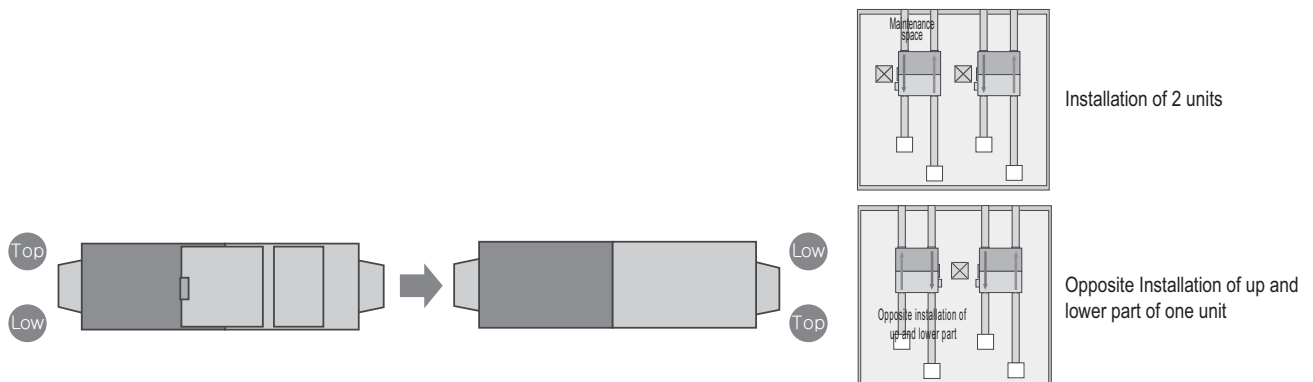

■ Auto Restart Operation

- When there's Electricity failure to the unit. After resumption of the Power, It starts in the same mode as prior to the power failure. This is as per the memorized condition. Any change will be memorized automatically to the MICOM & it takes about 2 secs to keep it.

■ Interlocking with Air Conditioning System :

- It is able to install the ventilation system being interlocking with the air conditioner. It can be also controlled individually or integral with the air condition.
- This function can be operated when connecting with specified Remote controller

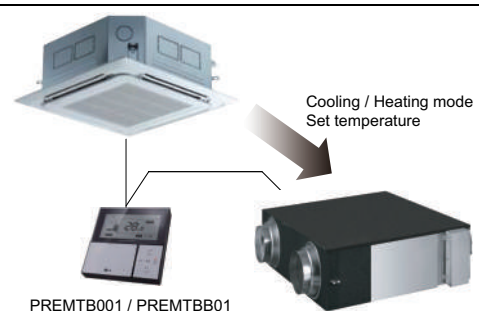

3. Features & Benefits

■ Excellent Sound Arresting Blocking Effect :

- The enthalpy heat exchanger element is difficult to convey the vibration of air with structure and it has a function of absorbing sounds.if it is installed a building in a serious noise place,it will be much more effective.

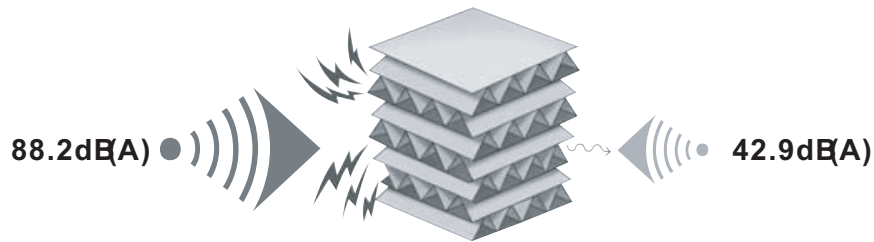

(45.3dB(A) Sound arresting blocking effect)

■ Air Filter

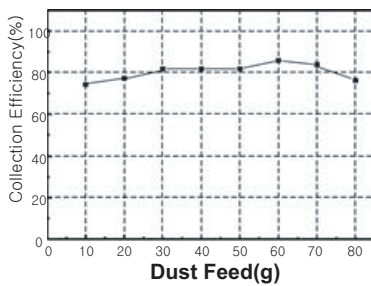

Polyethylene

- Air filter has sufficient effects with collection efficiency above 80%. It is even against floating particle from yellow sand.
- Few pressure loss in the static pressure plan.
- Excellent washing characteristic and durability.

3. Features & Benefits

■ LCD Wired Remote Control : (Accessory)

- It can control all the functions of the unit. You can check and change operation mode, set timer & also diagnose the error of the unit. It also has the option of weekly program.
- Built-in battery keeps user's operating setup information for 2 hours when the main power line to the wired remote controller is disconnected due to power outage as well.
- It can be installed with air conditioner remote controller, and each controller can control Ventilation and Air conditioner simultaneously.



PREMTB100

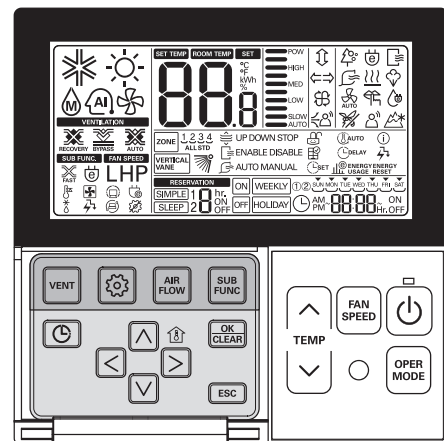

PREMTB001 / PREMTBB01

3. Features & Benefits

■ Group Control :

1. When installing more than 2 units of air conditioner to one wired remote controller, please connect as the below figure.

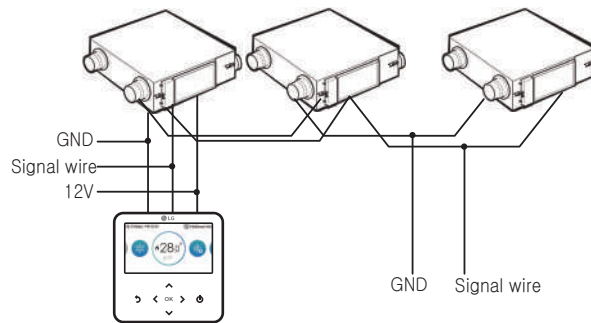

- If it is not event communication indoor unit, set the unit as slave.
- Check for event communication through the product manual.

When controlling multiple ventilation units with event communication function with one remote controller, you must change the master/slave setting from the indoor unit.

- Change the switch setting of the ventilation unit PCB.

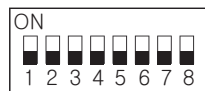

#1 switch OFF: Master
(Factory default setting)

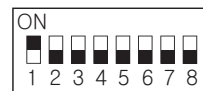

#1 switch ON: Slave

- * When installing 2 remote controllers to one indoor unit with event communication function, set the master/slave of the remote controller. (Refer to remote controller master/slave selection)
When controlling the group, some functions excluding basic operation setting, fan level Min/Mid/Max, remote controller lock setting and time setting may be limited.

2. When installing more than 2 wired remote controllers to one ventilation unit, please connect as the below picture.

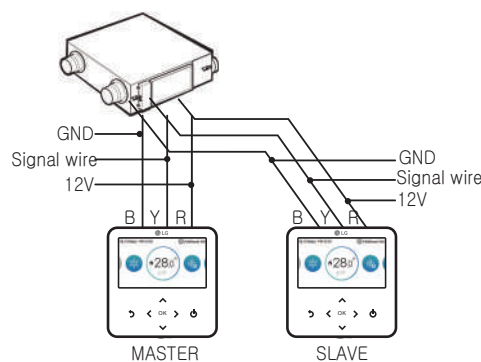

<When simultaneously connecting 2 sets of wired remote controller>

- When installing more than 2 units of wired remote controller to one ventilation unit, set one wired remote controller as master and the others all as slaves, as shown in the right picture.
 - You cannot control the group as shown in the right for some products.
 - Refer to the product manual for more detail.
- * When controlling in groups, set the master/slave of the remote controller. Refer to installer setting section on how to set master/slave for more detail.

3. Features & Benefits

■ Central Control : (Accessory)

- It enables to control $16 \times 8 = 128$ units with the help of 8 controllers. All units can be put on and off from one Central Room. For Setting Temperature, Fan speed and other sub functions, access the LCD wired remote controller of each unit.

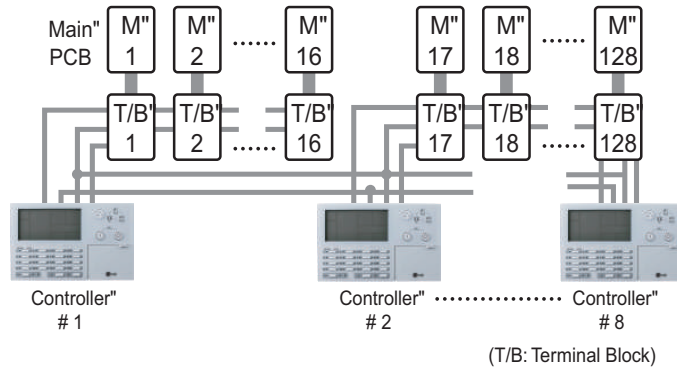

- This unit can be used as part of the combined operation system used together with indoor units (Multi-V system air conditioners), or as an independent system for processing outside air.

◆ Combined operation system with Multi-V system (connected with ventilation units and standard indoor units in a single refrigerant circuit)

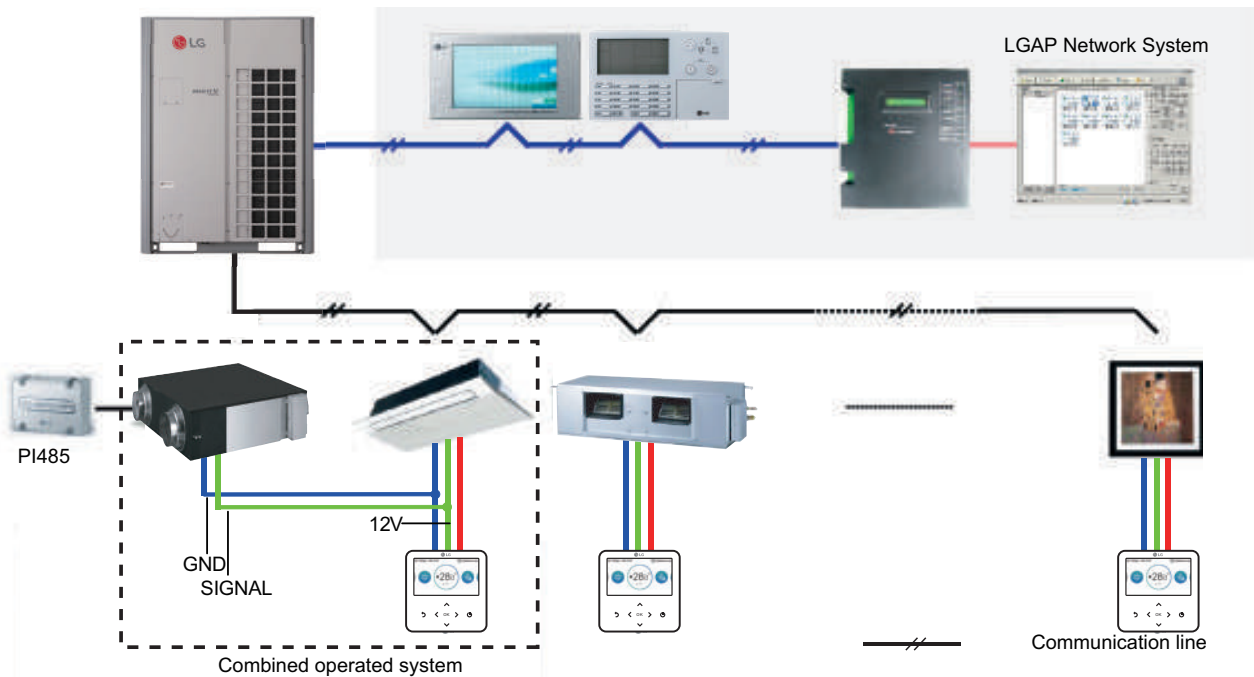

3. Features & Benefits

- ◆ Independent system (connected only with a ventilation unit in a single refrigerant circuit)

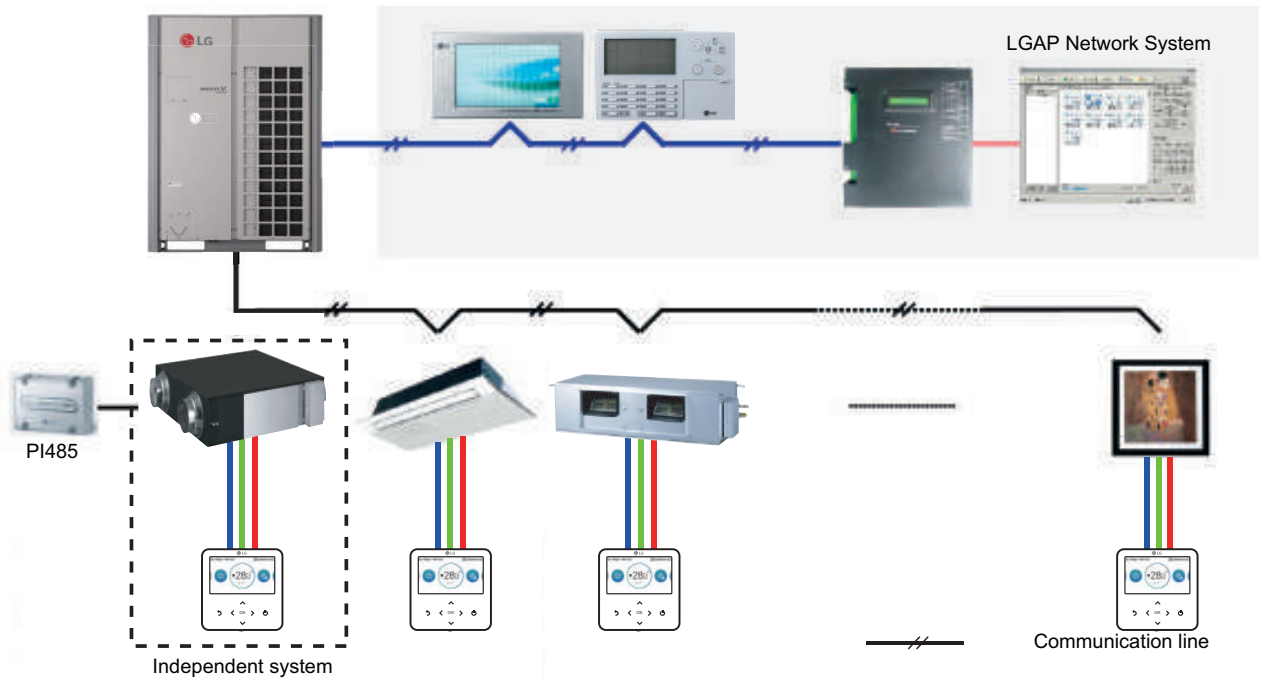

ERV

Energy Recovery Ventilator

Product Data

- 1.List of Functions**
- 2.Specifications**
- 3.Operation Range**
- 4.Dimensional Drawings**
- 5.Wiring Diagrams**
- 6.Characteristic Curve**
- 7.External Static Pressure**
- 8.Electrical Characteristics**
- 9.Sound Pressure Level**
- 10.Installation**
- 11.LCD Wired Remote Control**

1. List of Functions

◆ Basic functions of Indoor Unit

Category	Function	LZ-H025GBA4 LZ-H035GBA5 LZ-H050GBA5	LZ-H080GBA5 LZ-H100GBA5 LZ-H150GBA5 LZ-H200GBA5
Ventilation	Bypass Operation	O	O
	Heat Exchange Mode	O	O
	Seasonal Auto Operation	O	O
	Airflow steps by Ventilation Mode (Heat Exchange/Bypass/Auto)	3 / 3 / 3	3 / 3 / 3
	Airflow steps by Air conditioning Mode (Cooling/Heating/Auto)	- / - / -	- / - / -
Air Purification	Pre-Filter	O	O
	Fine Dust Filter	Accessory	Accessory
	UVnano	X	X
	Humidification	X	X
Reliability	Self Diagnosis	O	O
	Hot start	X	X
Convenience	CO ₂ fan control	O	O
	CO ₂ level display (Remote controller)	O	O
	CO ₂ level monitoring (Central controller)	O	O
	Fine dust level display (Outdoor/Indoor)	X	X
	Fast ventilation	O	O
	Filter Check Alarm	O	O
	Energy saving ventilation operation	O	O
	Auto Restart	O	O
	Child Lock	O	O
	Forced Operation	O	O
	Sleep Timer	O	O
	Turn On/Off Reservation	O	O
	Schedule	O	O
Interlocking air conditioner	Night Time Free Cooling	O	O
	Auto operation mode interlocking air conditioner	O	O
	Fast cleaning indoor air operation	O	O
	Air conditioner / ventilator control by single wired remote controller	O	O
	Delayed Operation (Delay time setting function)	O	O
	Interlock operation during IDU defrost	O	O
Installation	Group Control	O	O
	E.S.P Setting	O	O
	Test Function	O	O
	OA,EA Motorizes Damper Control	O	O
	Change OUTDOOR AIR / RETURN AIR SIDE	X	X
Special Functions	Wi-Fi Control	X	X
	Central Control (LGAP)	O	O

Note

- O : Applied, X : Not applied
 Accessory : Ordered and purchased separately the accessory package referring to the model name provided and install at field.
 Accessory line-ups varies by region, so check your local catalogue or local sales material.
- Some functions can be limited by remote controller, please refer to the remote control manual.

1. List of Functions

◆ Network solution Accessory List

Type	Product Name	Model	LZ-H025GBA4	LZ-H035GBA5 LZ-H050GBA5	LZ-H080GBA5 LZ-H100GBA5 LZ-H150GBA5 LZ-H200GBA5
Wired Remote Controller	Standard II (White)	PREMTB001	O	O	O
	Standard II (Black)	PREMTBB01	O	O	O
	Standard III (White)	PREMTB101	O	O	O
	Standard III (Black)	PREMTBB11	O	O	O
	Premium (English/Portuguese/Spanish/French)	PREMTA000	O	O	O
	Premium (English/Italian/Russian/Chinese)	PREMTA000A	O	O	O
	Premium (English/German/Polish/Czech)	PREMTA000B	O	O	O
	Deluxe	PREMTA200	X	X	X
	Deluxe	PREMTA201	X	X	X
Dry Contact	Simple (1 Input) Dry Contact	PDRYCB000	O	O	O
	Simple (1 Input) Dry Contact	PDRYCB100	O	O	O
	Dry Contact for Modbus (WITH CASE)	PDRYCB500	O	O	O
	Dry Contact for Modbus (WITHOUT CASE)	PDRYCB510	X	X	X
Gateway	PI485 (WITHOUT CASE)	PNF-P14A0C	X	X	X
		PHNFP14A0	X	X	X
	PI485 (WITH CASE)	PNF-P14A0R	X	X	X
		PSNFP14A0	O	O	O
	Modbus RTU	PMBUSB00A	O	O	O
Central Controller	Simple AC Ez	PQCSZ250S0	O	O	O
		PCS-Z150S0	X	X	X
	AC Ez Touch	PACEZA000	O	O	O
		PACEZB000	X	X	X
	AC Smart 5	PACS5A000	O	O	O
	ACP 5	PACP5A000	O	O	O
	AC Manager 5	PACM5A000	O	O	O
Accessory	Group control wire (0.25m)	PZCWRCG3	O	O	O
		PCW-QG00A	X	X	X
	Extension Wire (10m)	PZCWRC1	O	O	O
		PCW-QE10A	X	X	X
	Wi-Fi Modem	PWFMDD200	X	X	X
	Independent Power Module	PRIP0	X	X	X
	Refrigerant Leakage Detection (R410A)	PRLDNVS0	X	X	X
	CO2 Sensor	AHCS100H0	Embedded	Embedded	Embedded
	Fine Dust Filter (ISO ePM1 75% (F7 Filter))	AHFT100H0	X	X	X
		AHFT035H0 (250CMH)	O	X	X
		AHFT050H0 (350, 500CMH)	X	O	X
		AHFT100H1 (800, 1000, 1500, 2000CMH)	X	X	O

Note

1. O: Possible, X: Impossible, - : Not applicable, Embedded : Included with product.
2. If you need more detail, please refer to the **BECON** PDB or the manual of product. (<http://partner.lge.com> > Select Your Region : Home> Doc.Library> Product > Control(BECON))

2. Specifications

Model		Unit	LZ-H025GBA4	
Nominal Capacity		CMH (CFM)	250 (147)	
Power Supply		Ø, V, Hz	1, 220 - 240, 50	
ERV mode	Step	-	SUPER-HIGH / HIGH / LOW	
	Current	SH / H / L Amps	0.70 / 0.60 / 0.42	
	Power Input	SH / H / L W	97 / 78 / 52	
	Air Flow	SH / H / L CMH (CFM)	250 / 250 / 150 (147 / 147 / 88)	
	External Static Pressure	SH / H / L Pa (inWTR)	100 / 70 / 50 (0.40 / 0.28 / 0.20)	
	Temperature Exchange Efficiency	SH / H / L %	80.0 / 80.0 / 83.0	
	Enthalpy Exchange Efficiency	Heating (SH / H / L) %		70 / 70 / 72
		Cooling (SH / H / L) %		66 / 66 / 68
	Energy Label	A+ to G Scale	-	A
	Sound Pressure Level	SH / H / L dB(A)		29 / 28 / 24
Sound Power Level	SH dB(A)		50	
Bypass mode	Step	-	SUPER-HIGH / HIGH / LOW	
	Current	SH / H / L Amps	0.70 / 0.60 / 0.42	
	Power Input	SH / H / L W	97 / 87 / 52	
	Air Flow	SH / H / L CMH (CFM)	250 / 250 / 150 (147 / 147 / 88)	
	External Static Pressure	SH / H / L Pa (inWTR)	100 / 70 / 50 (0.40 / 0.28 / 0.20)	
	Sound Pressure Level	SH / H / L dB(A)		29 / 29 / 25
Operation Range	Outdoor Air Temperature / Relative Humidity	°C / %RH	-10 ~ 40 / 20 ~ 80	
Heat Exchanger	Type	-	Air to Air cross flow heat exchange	
Net Weight		kg	44	
Dimension	W x H x D	mm	988 x 273 x 1,014	
Duct work*	Qty	EA	4	
	Size (Ø)	mm	Ø200	
Supply Air Fan	Qty	EA	1	
	Type	-	Direct-Drive Sirocco	
Exhaust Air Fan	Qty	EA	1	
	Type	-	Direct-Drive Sirocco	
Filters	Qty	EA	2	
	Type	-	Cleanable fibrous fleeces	
	Size (W x H x D)	mm	855 x 10 x 160	

Note

- Due to our policy of innovation some specifications may be changed without notification.
 - ERV mode: Total Heat Recovery Ventilation mode
 - Sound Level Values are measured at Noise Measuring chamber accordance with standard. Therefore, these values depend on the ambient conditions and values are normally higher in actual operation.
The Sound pressure level at the air discharge port is about 8dB(A) higher than the unit's operating sound.
 - Temperature and Enthalpy Exchange Efficiency are based on the following conditions.
Temperature Exchange Efficiency is tested at heating condition.
 - Cooling : Indoor Ambient Temp. 26.5°CDB / 64.5%RH, Outdoor Ambient Temp. 34.5°CDB / 75%RH
 - Heating : Indoor Ambient Temp. 20.5°CDB / 59.5%RH, Outdoor Ambient Temp. 5°CDB / 65%RH
- * : Refer to dimensional drawings.

2. Specifications

Model		Unit	LZ-H035GBA5	LZ-H050GBA5	
Nominal Capacity		CMH (CFM)	350 (206)	500 (294)	
Power Supply		Ø, V, Hz	1, 220 - 240, 50		
ERV mode	Step	-	SUPER-HIGH / HIGH / LOW		
	Current	SH / H / L	Amps	1.05 / 0.90 / 0.50	1.65 / 1.56 / 0.80
	Power Input	SH / H / L	W	150 / 125 / 60	247 / 230 / 95
	Air Flow	SH / H / L	CMH (CFM)	350 / 350 / 210 (206 / 206 / 123)	500 / 500 / 320 (294 / 294 / 188)
	External Static Pressure	SH / H / L	Pa (inWTR)	150 / 100 / 50 (0.60 / 0.40 / 0.20)	150 / 100 / 50 (0.60 / 0.40 / 0.20)
	Temperature Exchange Efficiency	SH / H / L	%	79.0 / 79.0 / 82.0	78.0 / 78.0 / 81.0
	Enthalpy Exchange Efficiency	Heating (SH / H / L)	%	75 / 75 / 80	75 / 75 / 78
		Cooling (SH / H / L)	%	71 / 71 / 75	68 / 68 / 75
	Energy Label	A+ to G Scale	-	B	B
	Sound Pressure Level	SH / H / L	dB(A)	35 / 32 / 26	37 / 36 / 28
Sound Power Level	SH / H / L	dB(A)	53 / 50 / 42	57 / 56 / 46	
Bypass mode	Step	-	Super-high / High / Low		
	Current	SH / H / L	Amps	1.05 / 0.90 / 0.50	1.65 / 1.56 / 0.80
	Power Input	SH / H / L	W	150 / 125 / 60	247 / 230 / 95
	Air Flow	SH / H / L	CMH (CFM)	350 / 350 / 210 (206 / 206 / 123)	500 / 500 / 320 (294 / 294 / 188)
	External Static Pressure	SH / H / L	Pa (inWTR)	150 / 100 / 50 (0.60 / 0.40 / 0.20)	150 / 100 / 50 (0.60 / 0.40 / 0.20)
	Sound Pressure Level	SH / H / L	dB(A)	35 / 33 / 26	37 / 37 / 28
Operation Range	Outdoor Air Temperature / Relative Humidity	°C / %RH	-10 ~ 40 / 20 ~ 80		
Heat Exchanger	Type	-	Air to Air cross flow heat exchange		
Net Weight		kg	44		
Dimension	W x H x D	mm	988 × 273 × 1,014		
Duct work*	Qty	EA	4		
	Size (Ø)	mm	Φ200		
Supply Air Fan	Qty	EA	1		
	Type	-	Direct-Drive Sirocco		
Exhaust Air Fan	Qty	EA	1		
	Type	-	Direct-Drive Sirocco		
Filters	Qty	EA	2		
	Type	-	Cleanable fibrous fleeces		
	Size (W x H x D)	mm	855 × 10 × 166		

Note

1. Due to our policy of innovation some specifications may be changed without notification.
 2. ERV mode: Total Heat Recovery Ventilation mode
 3. Sound Level Values are measured at Noise Measuring chamber accordance with standard. Therefore, these values depend on the ambient conditions and values are normally higher in actual operation.
The Sound pressure level at the air discharge port is about 8dB(A) higher than the unit's operating sound.
 4. Temperature and Enthalpy Exchange Efficiency are based on the following conditions.
Temperature Exchange Efficiency is tested at heating condition.
 - Cooling : Indoor Ambient Temp. 26.5°CDB / 64.5%RH, Outdoor Ambient Temp. 34.5°CDB / 75%RH
 - Heating : Indoor Ambient Temp. 20.5°CDB / 59.5%RH, Outdoor Ambient Temp. 5°CDB / 65%RH
- * : Refer to dimensional drawings.

2. Specifications

Model		Unit	LZ-H080GBA5	LZ-H100GBA5	
Nominal Capacity		CMH (CFM)	800 (471)	1,000 (589)	
Power Supply		Ø, V, Hz	1, 220 - 240, 50		
ERV mode	Step	-	Super-high / High / Low		
	Current	SH / H / L	Amps	2.13 / 1.75 / 1.00	2.92 / 2.38 / 1.40
	Power Input	SH / H / L	W	328 / 266 / 144	463 / 370 / 208
	Air Flow	SH / H / L	CMH (CFM)	800 / 800/ 660 (471 / 471 / 388)	1,000 / 1,000 / 800 (589 / 589 / 471)
	External Static Pressure	SH / H / L	Pa (inWTR)	160 / 100 / 50 (0.64 / 0.40 / 0.20)	160 / 100 / 50 (0.64 / 0.40 / 0.20)
	Temperature Exchange Efficiency	SH / H / L	%	81.0 / 81.0 / 83.0	79.0 / 79.0 / 80.9
	Enthalpy Exchange Efficiency	Heating (SH / H / L)	%	73 / 73 / 76	71 / 71 / 73
		Cooling (SH / H / L)	%	66 / 66 / 70	64 / 64 / 67
	Energy Label	A+ to G Scale	-	-	-
	Sound Pressure Level	SH / H / L	dB(A)	40 / 36 / 32	40 / 37 / 33
Sound Power Level	SH / H / L	dB(A)	56 / 53 / 47	59 / 56 / 52	
Bypass mode	Step	-	Super-high / High / Low		
	Current	SH / H / L	Amps	2.13 / 1.75 / 1.00	2.92 / 2.38 / 1.40
	Power Input	SH / H / L	W	328 / 266 / 144	463 / 370 / 208
	Air Flow	SH / H / L	CMH (CFM)	800 / 800/ 660 (471 / 471 / 388)	1,000 / 1,000 / 800 (589 / 589 / 471)
	External Static Pressure	SH / H / L	Pa (inWTR)	160 / 100 / 50 (0.64 / 0.40 / 0.20)	160 / 100 / 50 (0.64 / 0.40 / 0.20)
	Sound Pressure Level	SH / H / L	dB(A)	41 / 37 / 33	41 / 38 / 34
Operation Range	Outdoor Air Temperature / Relative Humidity	°C / %RH	-10 ~ 40 / 20 ~ 80		
Heat Exchanger	Type	-	Air to Air cross flow heat exchange		
Net Weight		kg	62.8		
Dimension	W x H x D	mm	1,101 x 405 x 1,230		
Duct work*	Qty	EA	4		
	Size (Ø)	mm	Φ 250		
Supply Air Fan	Qty	EA	1		
	Type	-	Direct-Drive Sirocco		
Exhaust Air Fan	Qty	EA	1		
	Type	-	Direct-Drive Sirocco		
Filters	Qty	EA	2		
	Type	-	Cleanable fibrous fleeces		
	Size (W x H x D)	mm	1,148 x 6 x 245		

Note

1. Due to our policy of innovation some specifications may be changed without notification.
 2. ERV mode: Total Heat Recovery Ventilation mode
 3. Sound Level Values are measured at Noise Measuring chamber accordance with standard. Therefore, these values depend on the ambient conditions and values are normally higher in actual operation.
The Sound pressure level at the air discharge port is about 8dB(A) higher than the unit's operating sound.
 4. Temperature and Enthalpy Exchange Efficiency are based on the following conditions.
Temperature Exchange Efficiency is tested at heating condition.
 - Cooling : Indoor Ambient Temp. 26.5°CDB / 64.5%RH, Outdoor Ambient Temp. 34.5°CDB / 75%RH
 - Heating : Indoor Ambient Temp. 20.5°CDB / 59.5%RH, Outdoor Ambient Temp. 5°CDB / 65%RH
- * : Refer to dimensional drawings.

2. Specifications

Model		Unit	LZ-H150GBA5	LZ-H200GBA5	
Nominal Capacity		CMH (CFM)	1,500 (883)	2,000 (1,177)	
Power Supply		Ø, V, Hz	1, 220 - 240, 50		
ERV mode	Step	-	Super-high / High / Low		
	Current	SH / H / L	Amps	4.26 / 3.50 / 2.00	5.92 / 4.76 / 2.80
	Power Input	SH / H / L	W	660 / 530 / 290	926 / 740 / 420
	Air Flow	SH / H / L	CMH (CFM)	1,500 / 1,500 / 1,200 (883 / 883 / 706)	2,000 / 2,000 / 1,600 (1,177 / 1,177 / 942)
	External Static Pressure	SH / H / L	Pa (inWTR)	160 / 100 / 50 (0.64 / 0.40 / 0.20)	160 / 100 / 50 (0.64 / 0.40 / 0.20)
	Temperature Exchange Efficiency	SH / H / L	%	81.0 / 81.0 / 83.0	79.0 / 79.0 / 80.9
	Enthalpy Exchange Efficiency	Heating (SH / H / L)	%	73 / 73 / 76	71 / 71 / 73
		Cooling (SH / H / L)	%	66 / 66 / 70	64 / 64 / 67
	Energy Label	A+ to G Scale	-	-	-
	Sound Pressure Level	SH / H / L	dB(A)	43 / 39 / 35	43 / 40 / 36
Sound Power Level	SH / H / L	dB(A)	59 / 56 / 50	62 / 59 / 55	
Bypass mode	Step	-	Super-high / High / Low		
	Current	SH / H / L	Amps	4.26 / 3.50 / 2.00	5.92 / 4.76 / 2.80
	Power Input	SH / H / L	W	660 / 530 / 290	926 / 740 / 420
	Air Flow	SH / H / L	CMH (CFM)	1,500 / 1,500 / 1,200 (883 / 883 / 706)	2,000 / 2,000 / 1,600 (1,177 / 1,177 / 942)
	External Static Pressure	SH / H / L	Pa (inWTR)	160 / 100 / 50 (0.64 / 0.40 / 0.20)	160 / 100 / 50 (0.64 / 0.40 / 0.20)
	Sound Pressure Level	SH / H / L	dB(A)	44 / 40 / 36	44 / 41 / 37
Operation Range	Outdoor Air Temperature / Relative Humidity	°C / %RH	-10 ~ 40 / 20 ~ 80		
Heat Exchanger	Type	-	Air to Air cross flow heat exchange		
Net Weight		kg	156		
Dimension	W x H x D	mm	1,351 x 822 x 1,230		
Duct work*	Qty	EA	4 + 2		
	Size (Ø)	mm	Φ250 + Φ350		
Supply Air Fan	Qty	EA	2		
	Type	-	Direct-Drive Sirocco		
Exhaust Air Fan	Qty	EA	2		
	Type	-	Direct-Drive Sirocco		
Filters	Qty	EA	4		
	Type	-	Cleanable fibrous fleeces		
	Size (W x H x D)	mm	1,148 x 6 x 245		

Note

1. Due to our policy of innovation some specifications may be changed without notification.
 2. ERV mode: Total Heat Recovery Ventilation mode
 3. Sound Level Values are measured at Noise Measuring chamber accordance with standard. Therefore, these values depend on the ambient conditions and values are normally higher in actual operation.
The Sound pressure level at the air discharge port is about 8dB(A) higher than the unit's operating sound.
 4. Temperature and Enthalpy Exchange Efficiency are based on the following conditions.
Temperature Exchange Efficiency is tested at heating condition.
 - Cooling : Indoor Ambient Temp. 26.5°CDB / 64.5%RH, Outdoor Ambient Temp. 34.5°CDB / 75%RH
 - Heating : Indoor Ambient Temp. 20.5°CDB / 59.5%RH, Outdoor Ambient Temp. 5°CDB / 65%RH
- * : Refer to dimensional drawings.

2. Specifications

■ Guide Specification

◆ General

Units shall be completely factory assembled including fan motors, filters, heat exchanger element(s) and controls in a sheet metal casing.

◆ Casing

Unit casing shall be constructed of zinc coated, heavy gauge galvanized steel. All panels in the casing shall be cleaned with permanent, fire retardant, odorless material. Knockouts shall be provided for unit electrical power. Panels shall be fastened by screws.

◆ Heat Exchanger Element

The heat exchanger element shall be assembled without moving parts for higher durability and reliability. The material is flame-retardant for safety. The supply air passage and the exhaust air passage are arranged in right angle to prevent the supply and exhaust air from getting mixed.

◆ Fan Motor

The fan motors shall be of permanently lubricated type with internal thermal protection as standard. The shaft shall be protected against rusting. The fan motors shall be resilient mounted to minimize vibration and noise. All fans shall be statically and dynamically balanced for quiet operation.

◆ Filters

Filters shall be easily accessible from the side of the unit. Filters shall be fabricated from synthetic media and shall be of washable type.

◆ Control

Wired control shall be available as standard. The controls shall be microprocessor based and provide for a user interface.

3. Operation Range

■ Operation Range and details by temperature range

Operation range of ERV model is in the below table.

Operation Range			Operative	Normal Operation Range				Operative	
Outdoor Air Temperature			-10℃ ↓	-10℃ ~ 0℃	0℃ ~ 8℃	8℃ ~ 40℃	40℃ ~ 45℃	45℃ ↑	
Ventilation Mode			ERV	ERV	ERV	Set Operation Mode	ERV	ERV	
Fan Operation	Dip SW 5 Off (Default)	Exhaust	Low	Low	Set Air Flow Step	Set Air Flow Step	Intermittent*	Low	
		Supply	OFF	Low	Set Air Flow Step	Set Air Flow Step	Intermittent*	OFF	
	Dip SW 5 On	Exhaust	OFF	Low	Set Air Flow Step	Set Air Flow Step	Intermittent*	OFF	
		Supply	OFF	Low	Set Air Flow Step	Set Air Flow Step	Intermittent*	OFF	

Note

- Because there is a hysteresis range(2℃), the real temperature point at which the ventilation and fan operation mode changes could be different with this table.
- ERV ventilation : Energy(Total Heat) Recovery Mode
It is the mode of ventilation with both supply/discharge through the total heat exchanger. It is adequate to use when the indoor/outdoor temperature difference is big.
- Bypass ventilation : General Ventilation Mode.
It is the ventilation where the exhausted air is ventilated without going through the total heat exchanger. (Ventilation : O, Energy Recovery : X)
It is adequate to use when the indoor contamination is severe.

*** Intermittent Operation Control (Fan operation)**

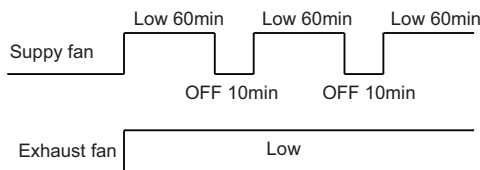

4. Dimensional Drawings

◆ LZ-H025GBA4

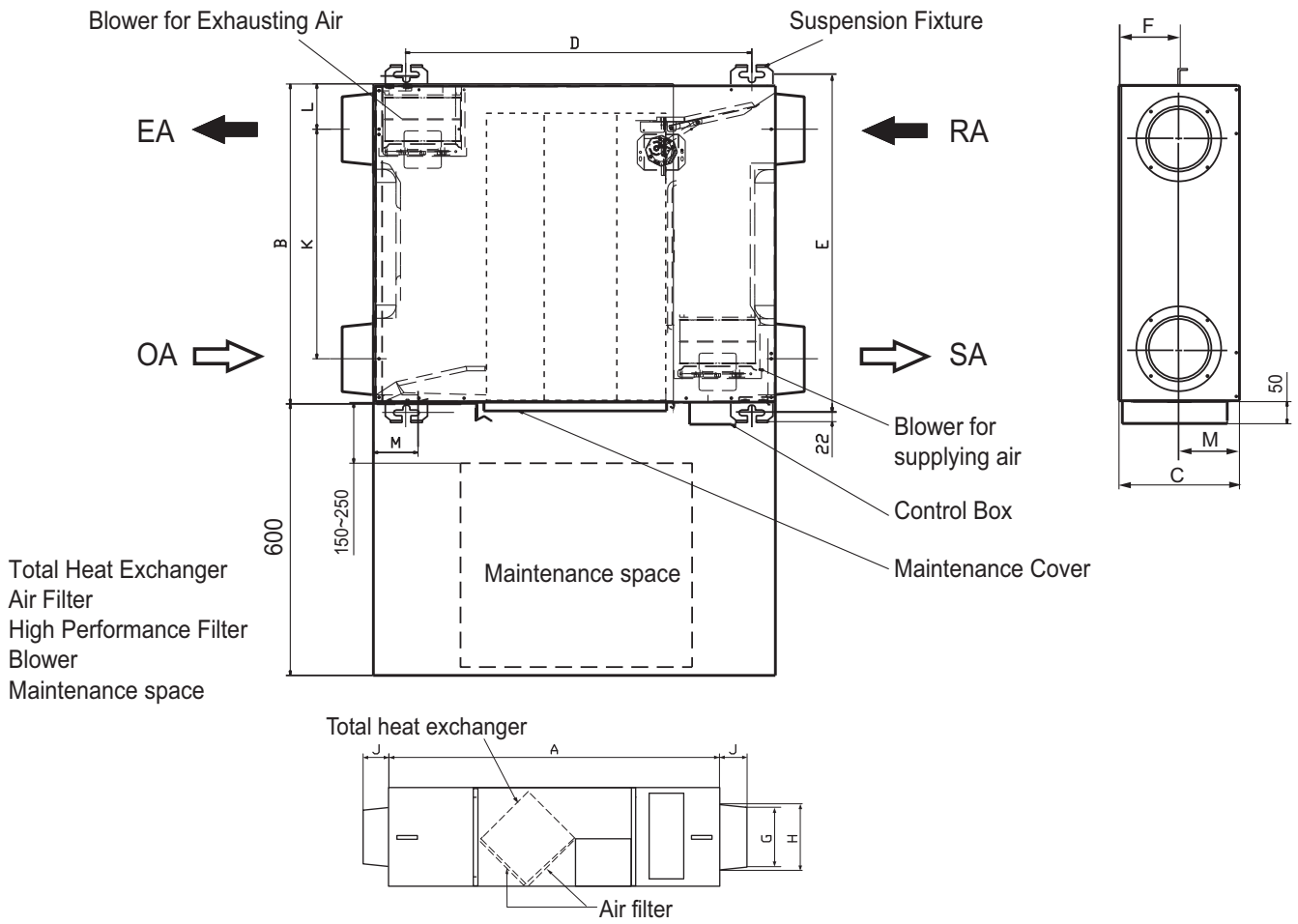

Unit : mm

Model	Figure			Pitch of Suspension Fixture			Nominal Diameter	Duct Connection Flange			Duct Pitch		
	A	B	C	D	E	F		G	H	J	K	L	M
LZ-H025GBA4	1,014	988	273	939	1,020	135	200	194	240	96	590	198	142

4. Dimensional Drawings

◆ LZ-H035GBA5 / LZ-H050GBA5

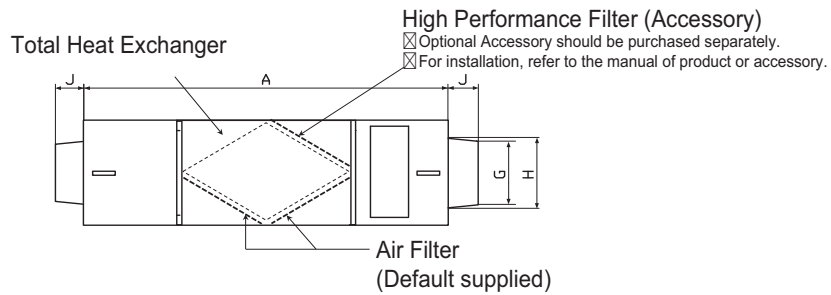
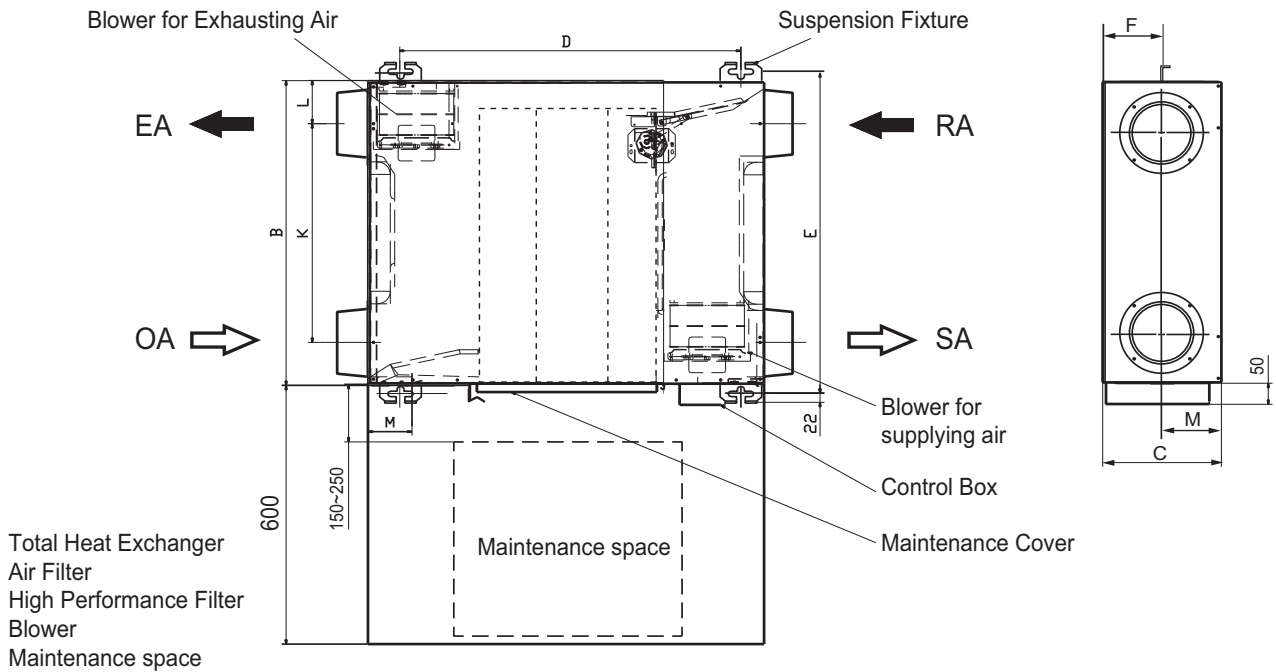

Unit : mm

Model	Figure			Pitch of Suspension Fixture			Nominal Diameter	Duct Connection Flange			Duct Pitch		
	A	B	C	D	E	F		G	H	J	K	L	M
LZ-H035GBA5 LZ-H050GBA5	1,014	988	273	939	1,020	135	200	194	240	96	590	198	142

4. Dimensional Drawings

◆ LZ-H080GBA5 / LZ-H100GBA5

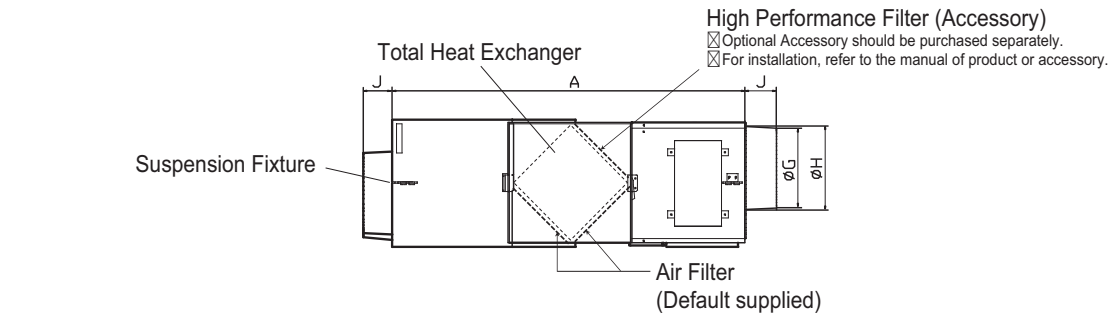
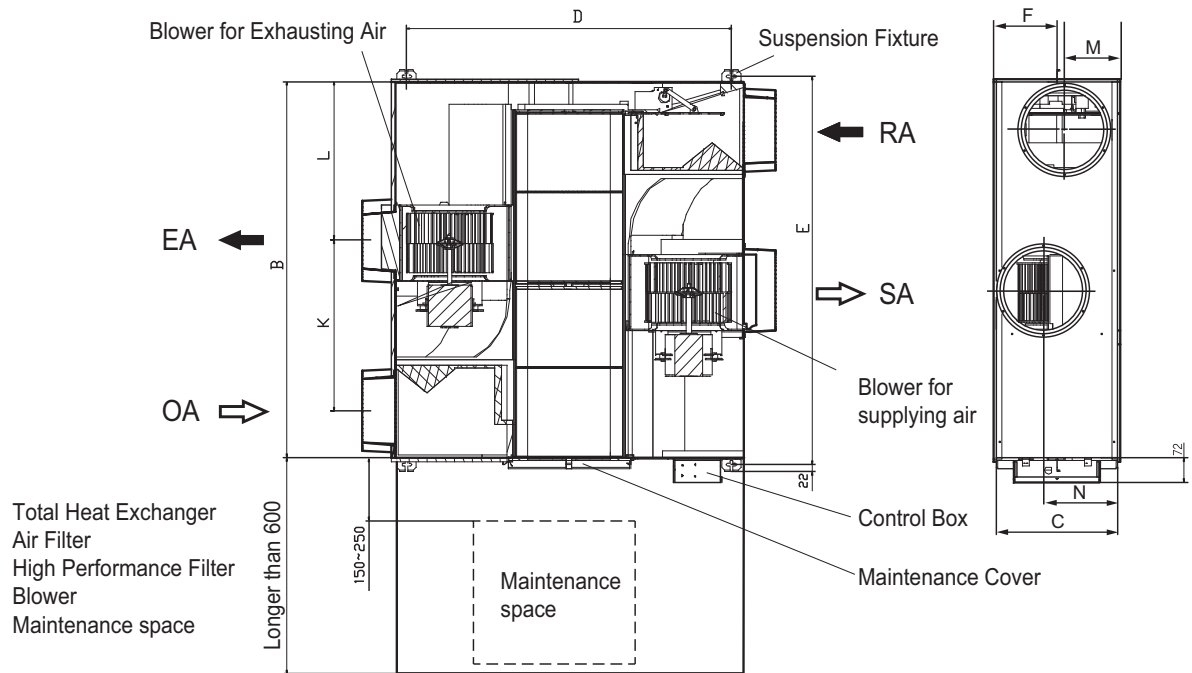

Unit : mm

Model	Figure			Pitch of Suspension Fixture			Nominal Diameter	Duct Connection Flange			Duct Pitch			
	A	B	C	D	E	F		G	H	J	K	L	M	N
LZ-H080GBA5 LZ-H100GBA5	1,101	1,230	405	1,026	1,263	269	250	244	254	77	567	519	174	248

4. Dimensional Drawings

◆ LZ-H150GBA5 / LZ-H200GBA5

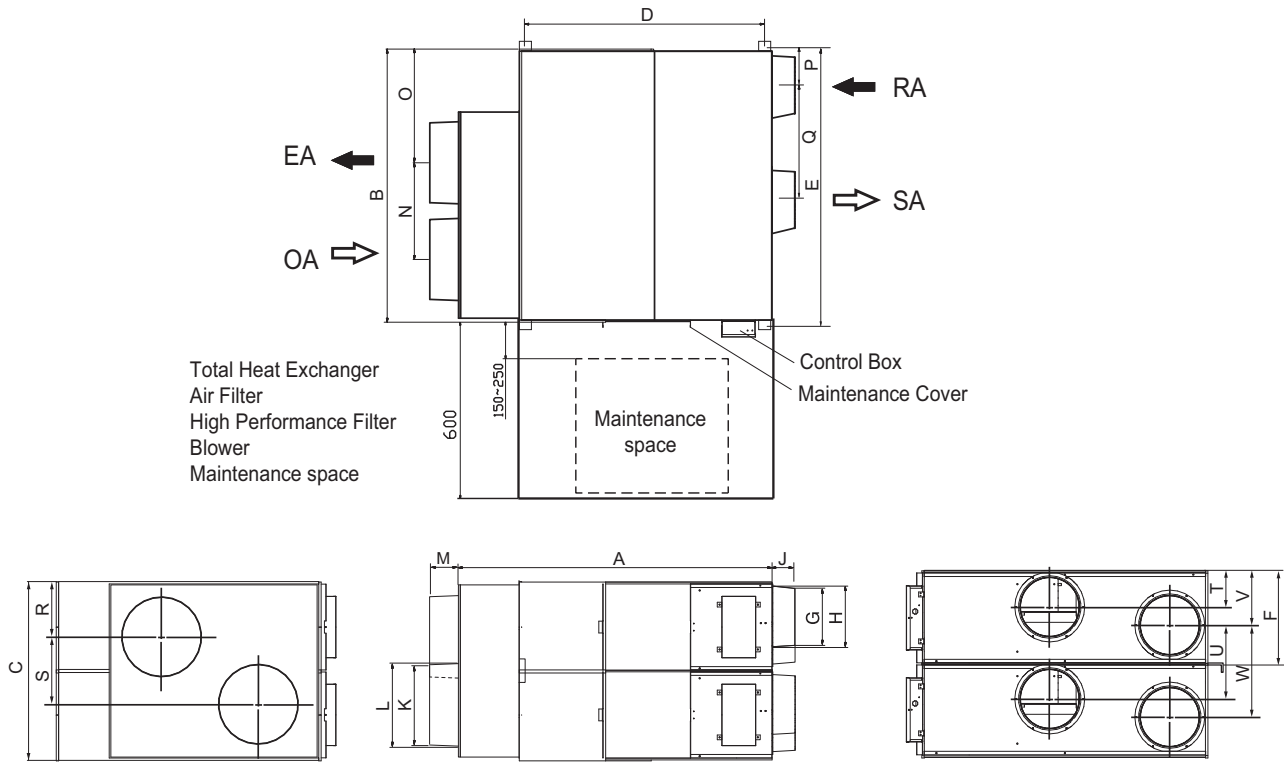

Unit : mm

Model	Figure			Pitch of Suspension Fixture			Duct Connection Flange					
	A	B	C	D	E	F	G	H	J	K	L	M
LZ-H150GBA5 LZ-H200GBA5	1,351	1,230	822	1,031	1,288	363	244	254	77	340	350	130

Model	Nominal Diameter		Duct Pitch									
	EA	SA	N	O	P	Q	R	S	T	U	V	W
LZ-H150GBA5 LZ-H200GBA5	350	250	410	598	173	539	311	271	160	340	234	413

5. Wiring diagrams

LZ-H025GBA4 / LZ-H035GBA5 / LZ-H050GBA5

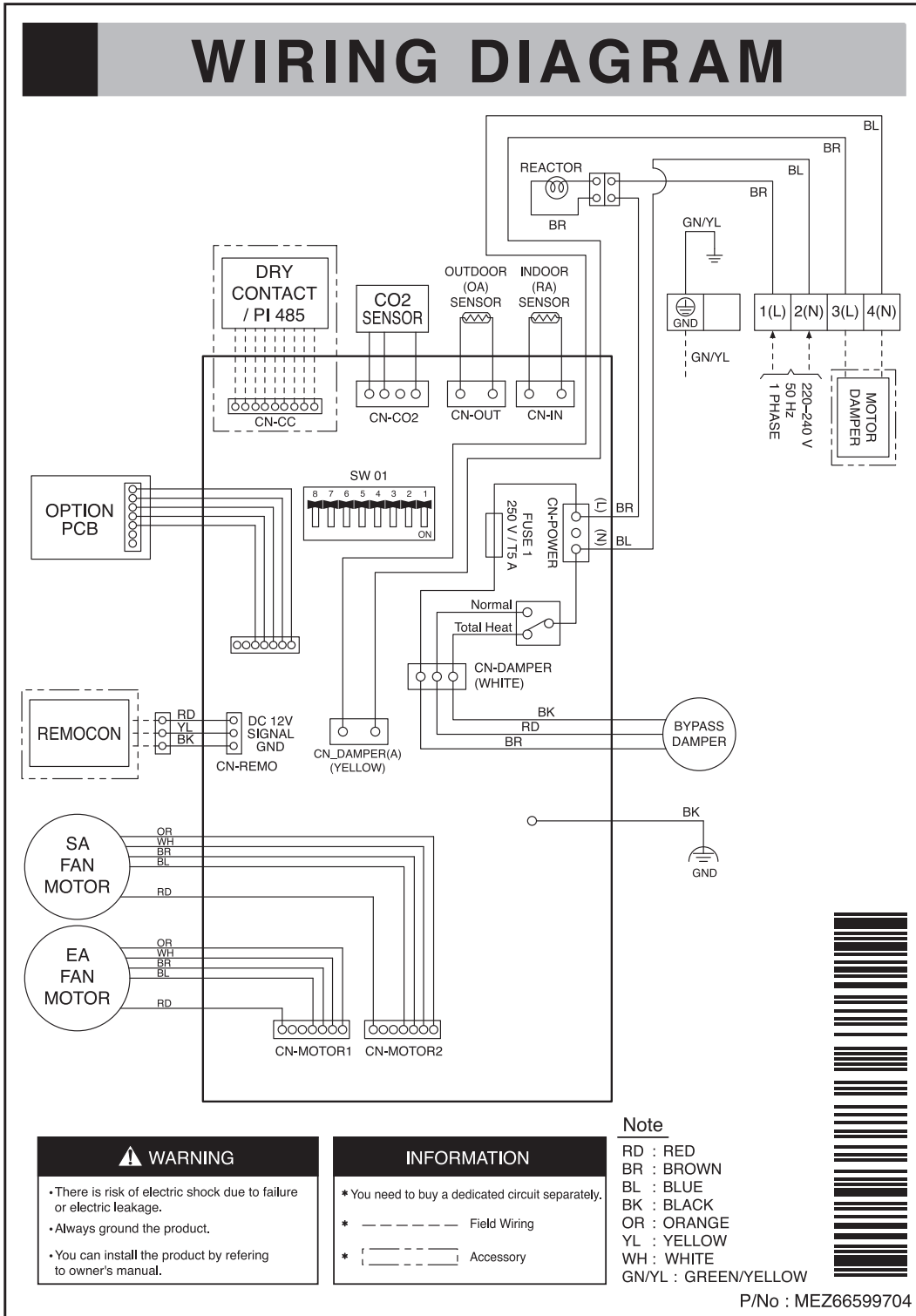

5. Wiring diagrams

LZ-H080GBA5 / LZ-H100GBA5

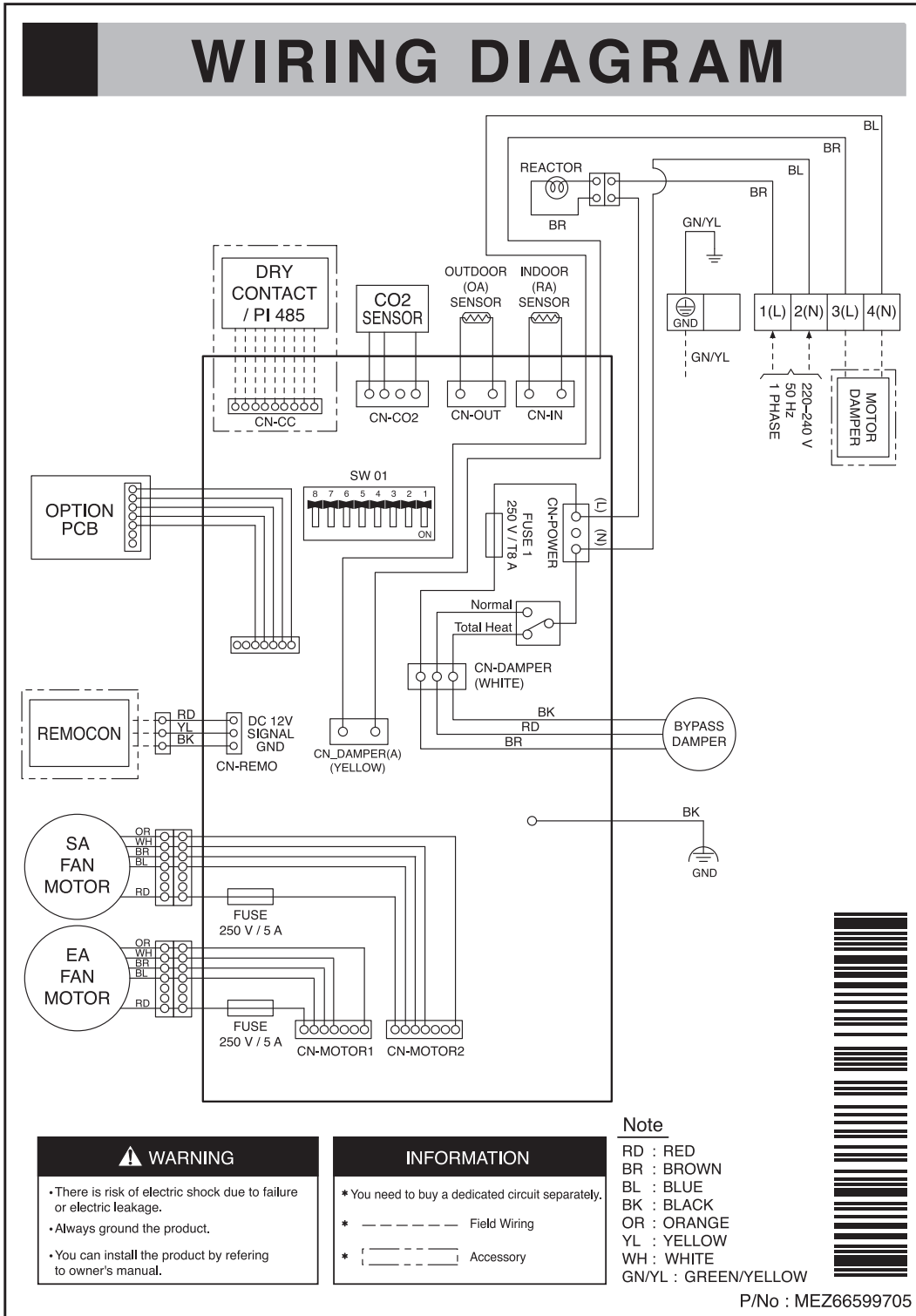

5. Wiring diagrams

LZ-H150GBA5 / LZ-H200GBA5

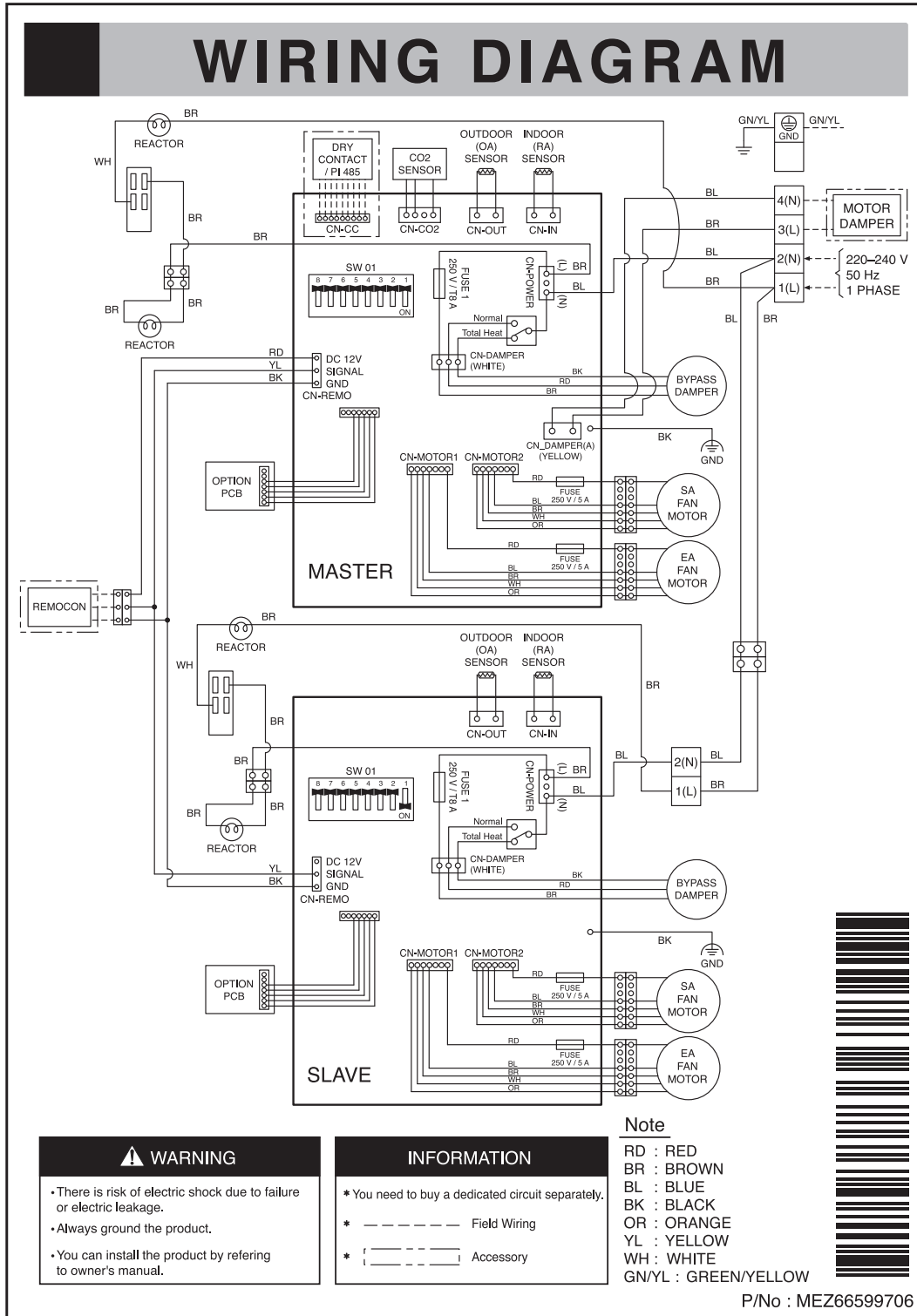

6. Characteristic Curve

6.1 LZ-H025GBA4

◆ Ventilation

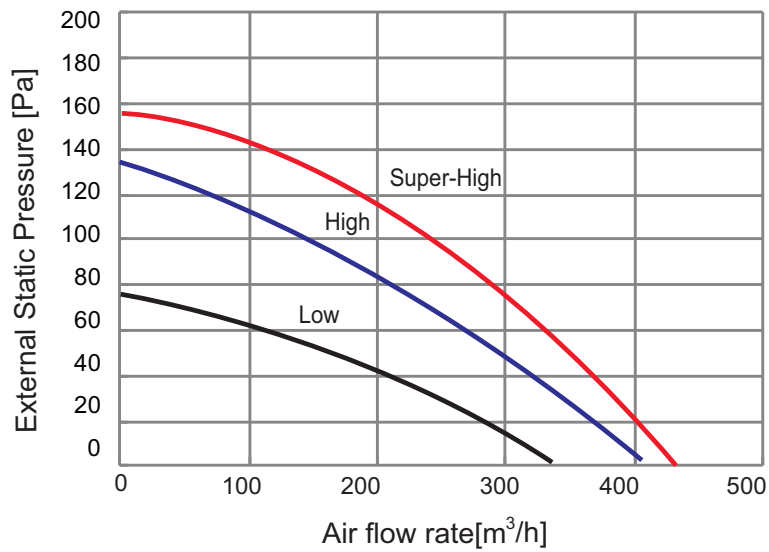

◆ Efficiency

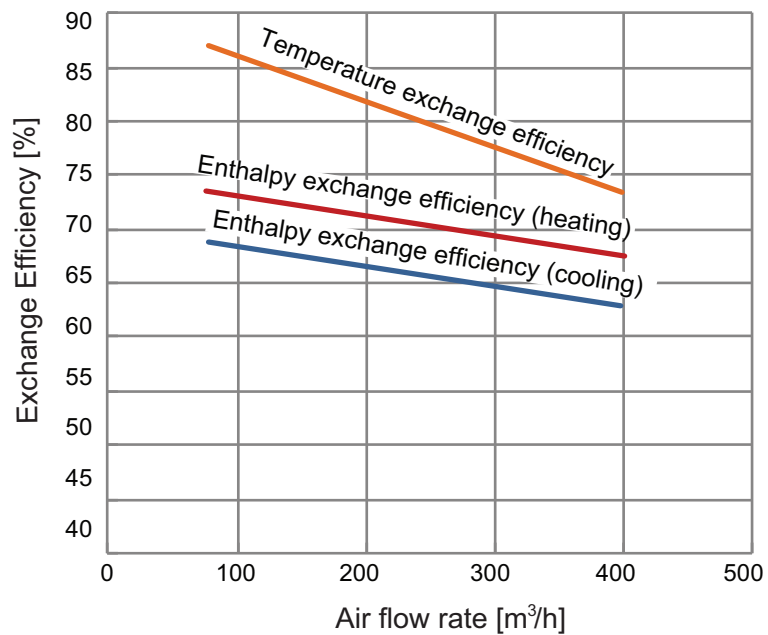

6. Characteristic Curve

Unit : mm

6.2 LZ-H035GBA5

◆ Ventilation

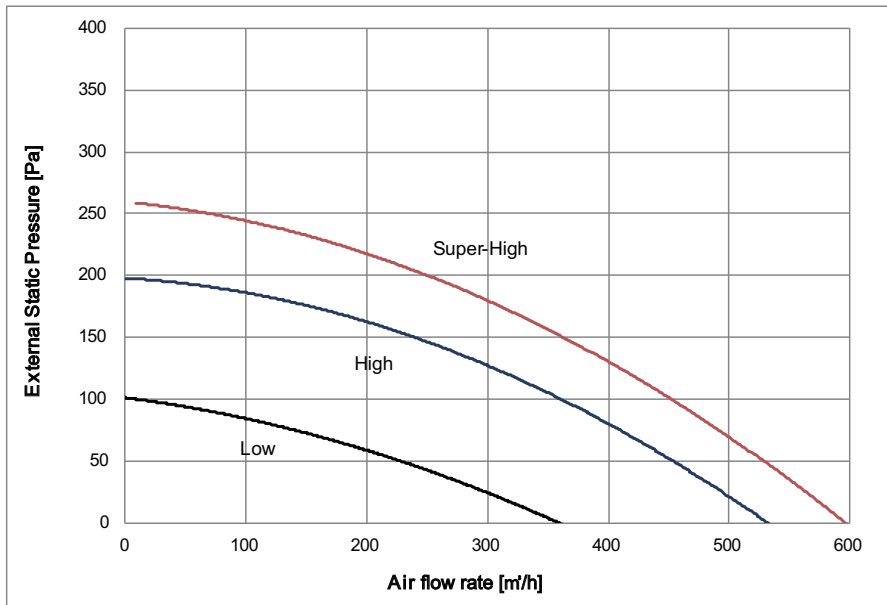

◆ Efficiency

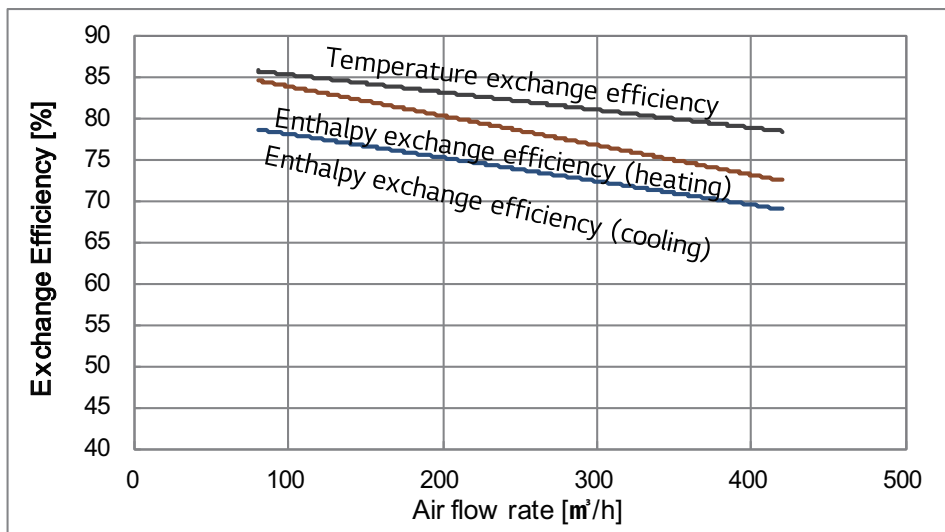

6. Characteristic Curve

6.3 LZ-H050GBA5

◆ Ventilation

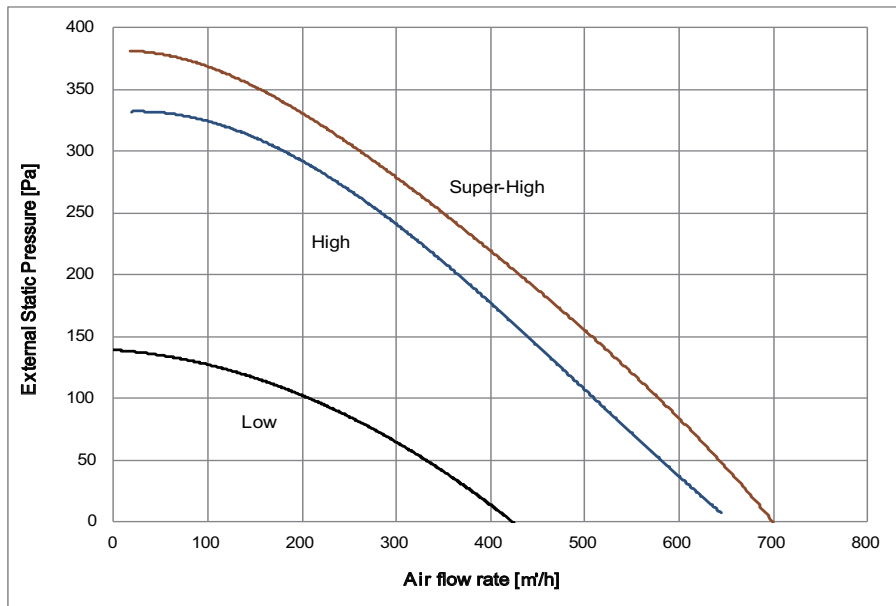

◆ Efficiency

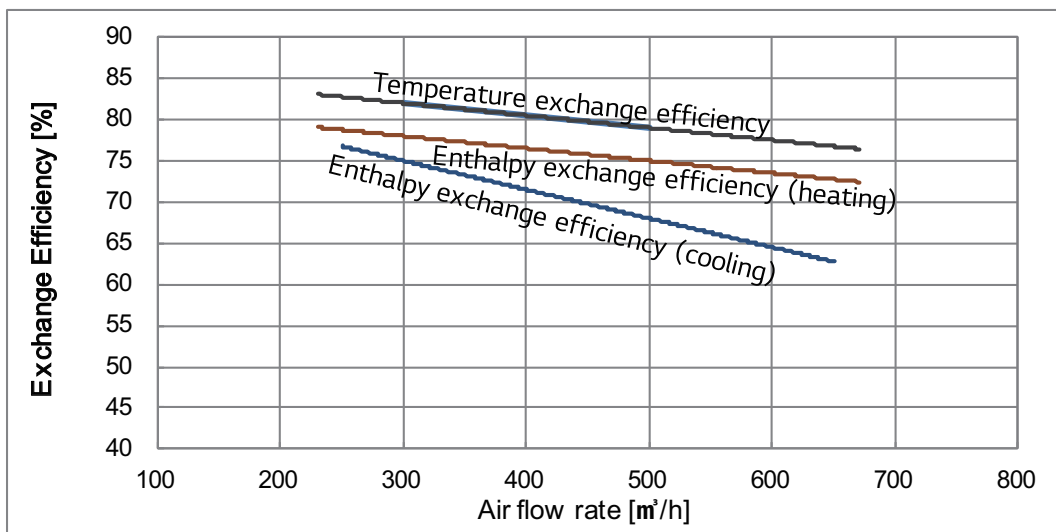

6. Characteristic Curve

6.4 LZ-H080GBA5

◆ Ventilation

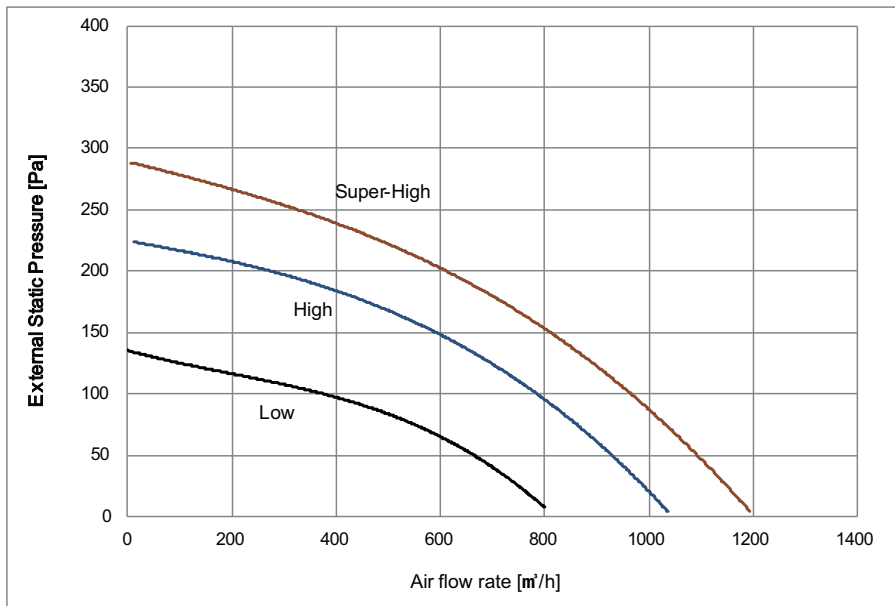

◆ Efficiency

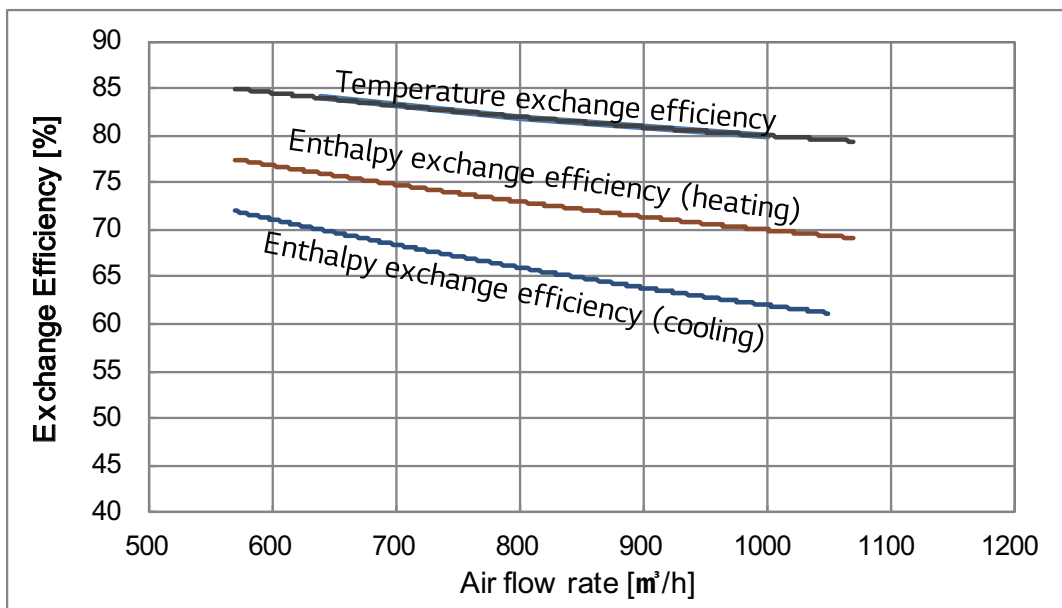

6. Characteristic Curve

6.5 LZ-H100GBA5

◆ Ventilation

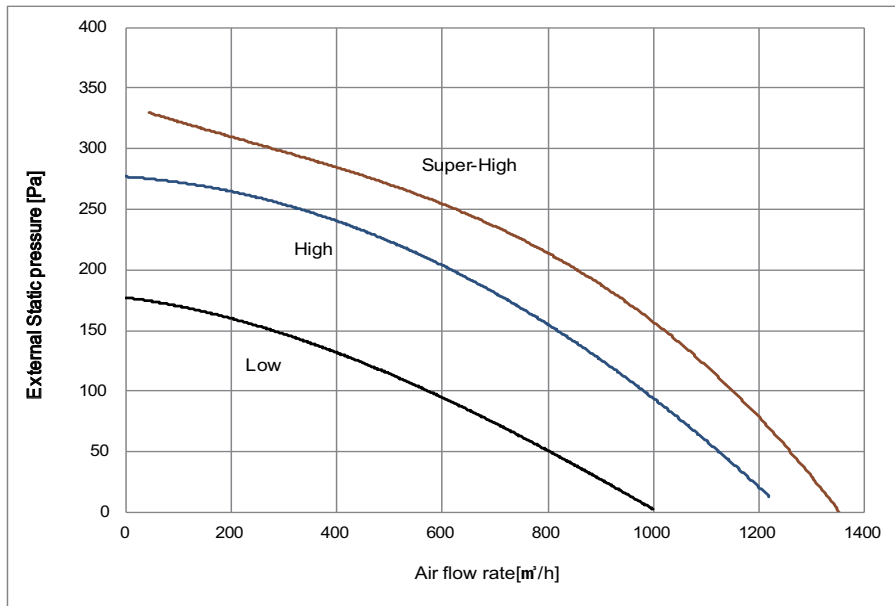

◆ Efficiency

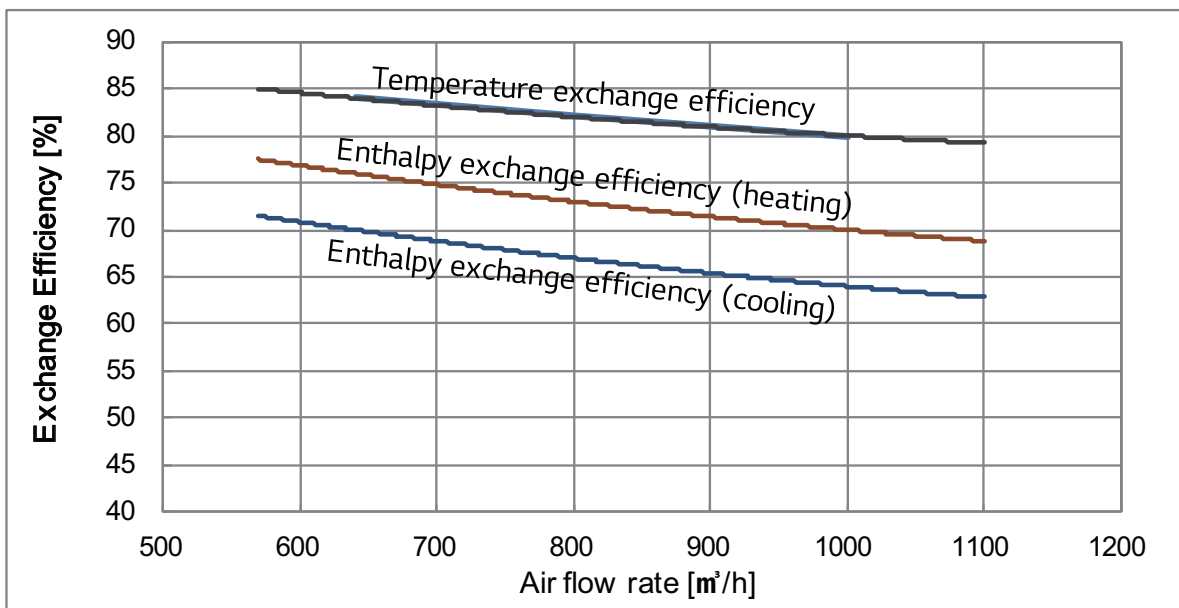

6. Characteristic Curve

6.6 LZ-H150GBA5

◆ Ventilation

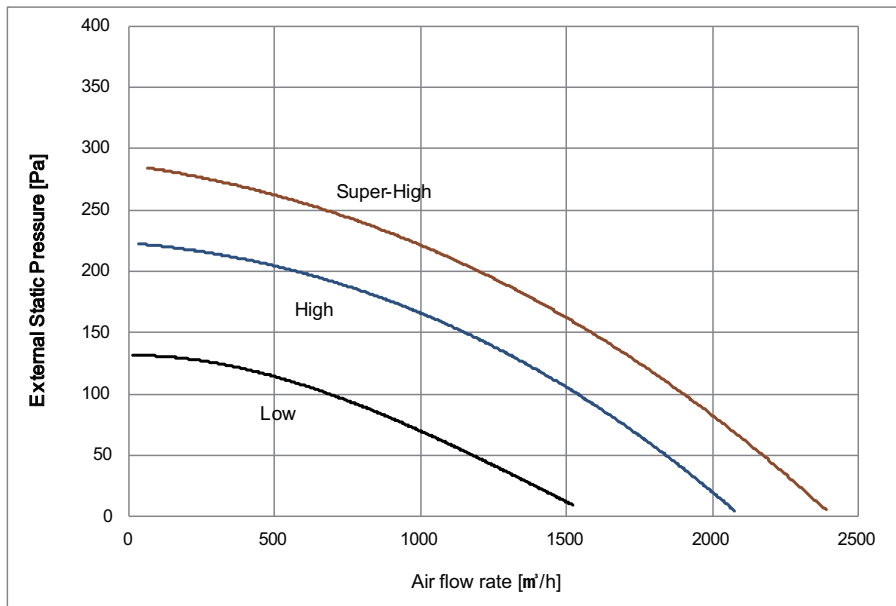

◆ Efficiency

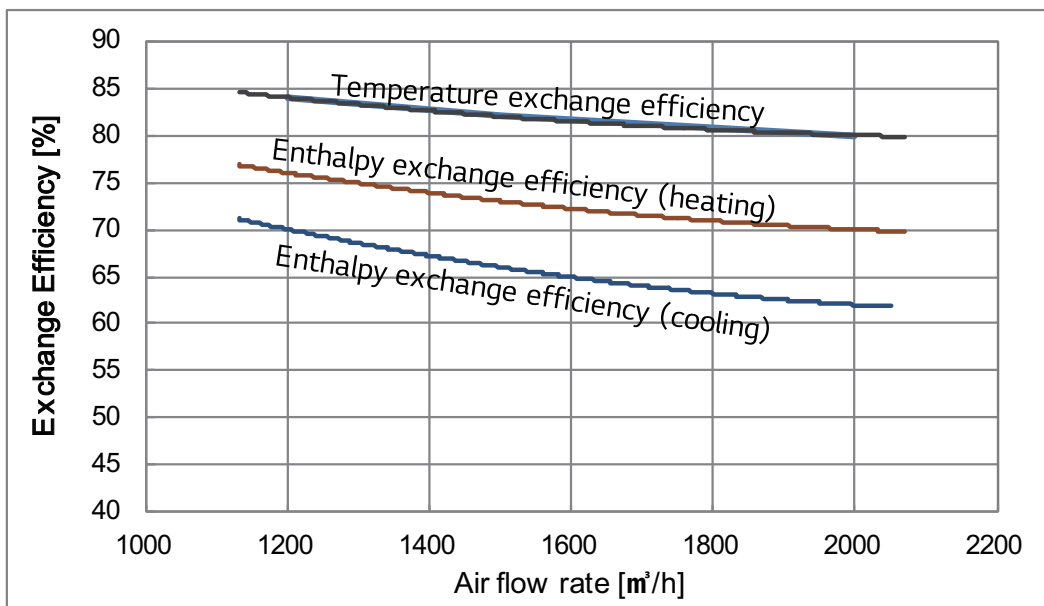

6. Characteristic Curve

6.7 LZ-H200GBA5

◆ Ventilation

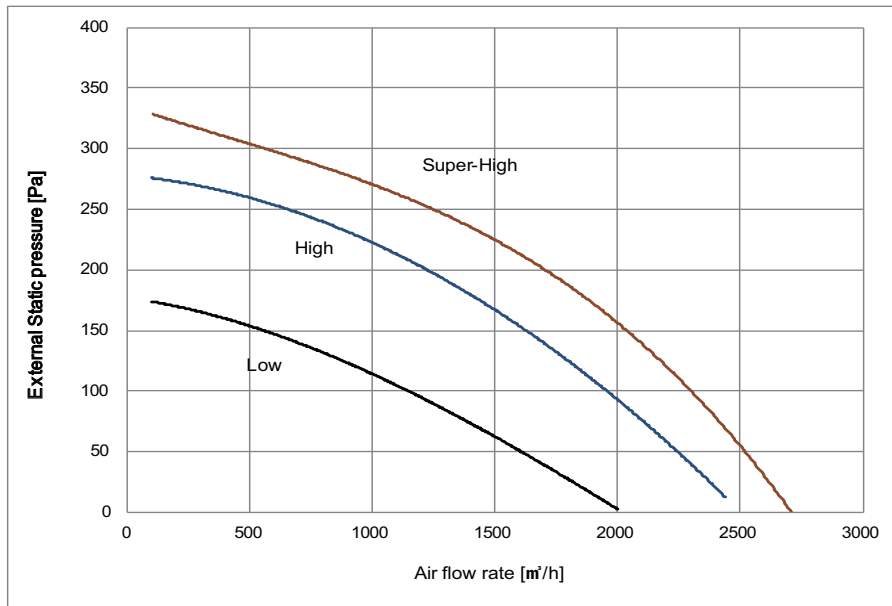

◆ Efficiency

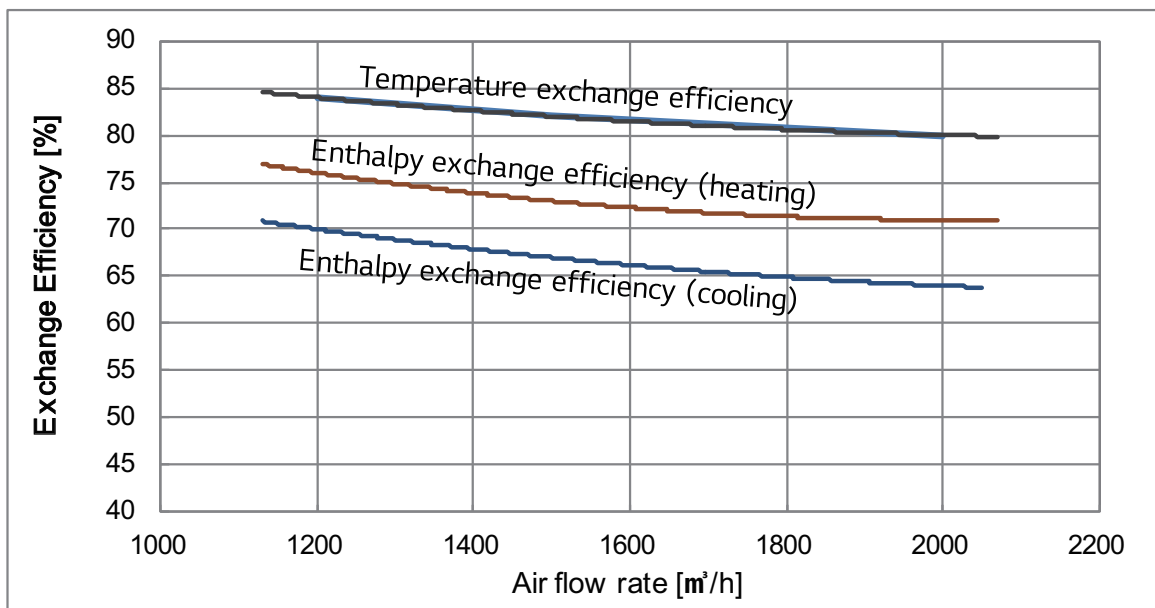

7. External Static Pressure Setting

7.1 Installer Setting – E.S.P(PREMTB100)

This is the function that decides the strength of the wind for each wind level and because this function is to make the installation easier.

⚠ CAUTION

- If ESP is incorrectly set, the air conditioner may malfunction.
- It must be set by the installation specialist with the installation license, and if it is installed or changed without installation license, all problems caused will be the responsibility of the installer, and may void the LG warranty.

■ Step 1. Installer setting entry

- In the menu screen, press [**<**, **>** (left/right)] button to select the setting category, and press [**^** (up)] button for 3 seconds to enter the password input screen for the installer setting.
- Input the password and press [**OK**] button to move to the installer setting list.

◆ Installer setting password

Main screen → menu → setting → service → RMC version information → SW Version

Example) SW version : 1.00.1 a
 In the above case, the password is 1001

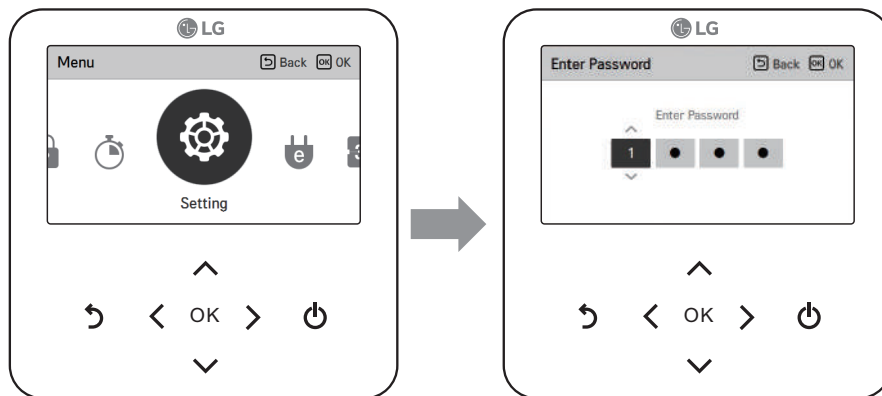

7. External Static Pressure Setting

Unit : mm

■ Step 2. Supply / Exhaust ESP setting

1. Select the wind strength with inputting [^, v (up/down)] button. (Low, High, Power)
2. Move the setting items with inputting [<, >(left/right)] button.
3. Select the RPM value of wind strength with inputting [^, v (up/down)] button. (0~255)
4. Complete the RPM setting with inputting [OK] button. (Send RPM setting data of indoor unit)

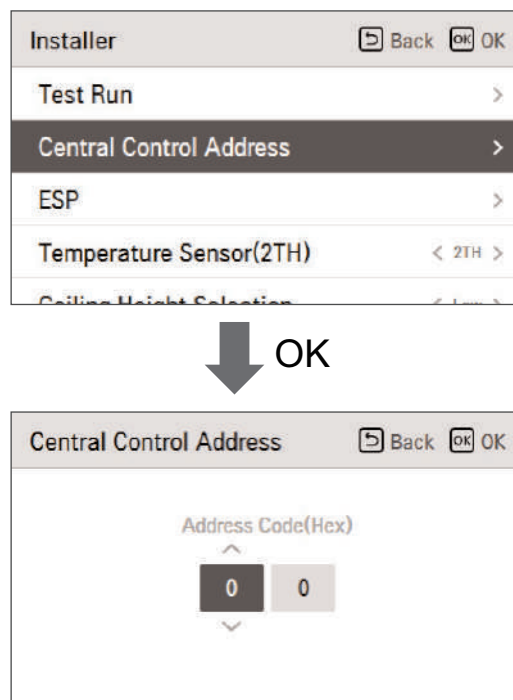

Note

- When setting ESP value on the product without very weak wind or power wind function, it may not work.
- For ventilation products, separate ESP values are used for the supply and exhaust fans.
- Be especially careful not to switch ESP values corresponding to each fan speed.
- The ESP values that can be set may be different for each product and capacity.









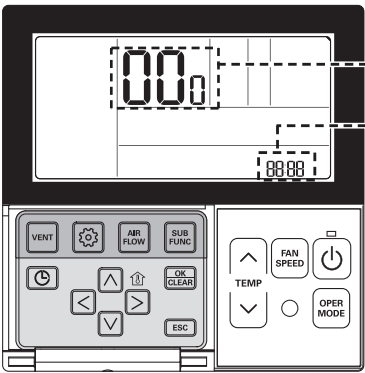



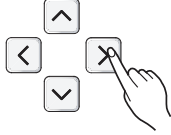

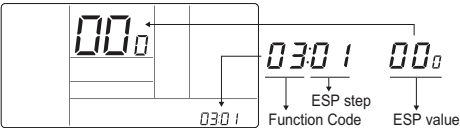
7. External Static Pressure Setting

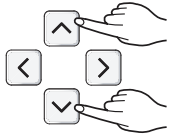
7.2 Installer Setting - E.S.P. (PREMTB001 / PREMTBB01)

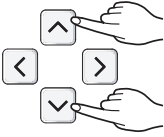
This is the function that decides the strength of the wind for each wind level and because this function is to make the installation easier.

- If you set ESP incorrectly, the air conditioner may malfunction.
- This setting must be carried out by a certificated-technician.



<p>1 If pressing  button long for 3 seconds, it enters into remote controller setter setup mode. - If pressing once shortly, it enters into user setup mode. Please press more than 3 seconds for sure.</p> 	<p>4 Move to ESP value setting by pressing  button. (It is 000 when delivering from the warehouse.)</p>  <p>0301 000</p>
<p>2 If entering into ESP setup mode by using  button, it indicates as the picture below.</p> <p>* Function code 03 : Supply fan 04 : Exhaust fan</p> 	<p>5 Press   button to setup ESP value. (It is possible to setup ESP value from 1 to 255, and 1 is the smallest and 255 is the biggest.)</p> 
<p>3 Select ESP fan step by pressing   button. (01: low, 02: high, 03: super-high)</p>  <p>0301</p>	<p>6 Select ESP fan step again by using   button and setup ESP value, as No. 4 and 5, that corresponds each wind flow</p> <p>7 Press  button to save.</p> 
<p>8 Press  button to exit. * After setup, it automatically gets out of setup mode if there is no button input for 25 seconds. * When exiting without pressing set button, the manipulated value is not reflected.</p>	

- When setting ESP value on the product without very weak wind or power wind function, it may not work.
- Please be careful not to change the ESP value for each fan step.
- It does not work to setup ESP value for very low/power step for some products.
- ESP value is available for specific range belongs to the product.

7. External Static Pressure Setting

■ RPM Table

◆ LZ-H025GBA4

Setting Value	External Static Pressure Pa (in.wg)				
	0 (0.0)	30 (0.1)	50 (0.2)	100 (0.4)	150 (0.6)
	Air Flow Rate [CMH]				
75	261	177	132	18	-
91	353	300	228	18	-
107	425	374	335	250	30

◆ LZ-H035GBA5

Setting Value	External Static Pressure Pa (in.wg)				
	0 (0.0)	30 (0.1)	50 (0.2)	100 (0.4)	150 (0.6)
	Air Flow Rate [CMH]				
75	261	177	132	-	-
91	353	290	240	10	-
107	445	390	350	220	-
125	533	491	455	350	240

◆ LZ-H050GBA5

Setting Value	External Static Pressure Pa (in.wg)							
	0 (0.0)	30 (0.1)	50 (0.2)	100 (0.4)	150 (0.6)	200 (0.8)	250 (1.0)	300 (1.2)
	Air Flow Rate [CMH]							
75	261	177	132	18	-	-	-	-
91	353	300	228	18	-	-	-	-
107	445	390	350	220	-	-	-	-
125	533	491	455	350	240	-	-	-
138	603	550	532	430	348	283	58	-
153	644	600	570	500	430	360	260	160

◆ LZ-H080GBA5

Setting Value	External Static Pressure Pa (in.wg)					
	0 (0.0)	30 (0.1)	50 (0.2)	100 (0.4)	150 (0.6)	200 (0.8)
	Air Flow Rate [CMH]					
65	586	420	285	17	-	-
82	775	686	609	349	17	-
93	926	831	780	600	280	-
105	1,037	979	939	800	600	270

◆ LZ-H100GBA5

Setting Value	External Static Pressure Pa (in.wg)						
	0 (0.0)	30 (0.1)	50 (0.2)	100 (0.4)	150 (0.6)	200 (0.8)	250 (1.0)
	Air Flow Rate [CMH]						
65	586	420	285	17	-	-	-
82	775	686	609	349	17	-	-
93	926	831	780	600	280	-	-
105	1,037	979	939	800	600	270	-
116	1,172	1,127	1,087	1,000	800	570	255

7. External Static Pressure Setting

◆ LZ-H150GBA5 / LZ-H200GBA5

Setting Value	External Static Pressure Pa (in.wg)							
	0 (0.0)	30 (0.1)	50 (0.2)	100 (0.4)	150 (0.6)	200 (0.8)	250 (1.0)	300 (1.2)
	Air Flow Rate [CMH]							
65	1,172	840	570	34	-	-	-	-
82	1,550	1,372	1,218	698	34	-	-	-
93	1,852	1,662	1,506	1,120	560	220	-	-
105	2,074	1,958	1,878	1,556	1,144	600	40	-
116	2,344	2,254	2,174	1,900	1,576	1,216	510	180
127	2,670	2,564	2,496	2,210	1,944	1,664	1,172	560
133	2,776	2,686	2,598	2,338	2,064	1,766	1,430	600
138	2,882	2,784	2,726	2,574	2,410	1,972	1,766	1,396

8. Electrical Characteristics

Units					Power Supply	IFM		PI	
Model	Type	Hz	Volts	Voltage Range	MCA	kW	FLA	Cooling	Heating
LZ-H035GBA5	ZD	50	220-240	Max. : 264 Min. : 198	1.10	0.25	0.97	150	40
LZ-H050GBA5	ZD				1.10	0.25	0.97	247	40
LZ-H080GBA5	ZE2				2.61	0.39	2.30	328	40
LZ-H100GBA5	ZE2				2.61	0.39	2.30	463	70
LZ-H150GBA5	ZF2				5.23	0.78	4.60	660	70
LZ-H200GBA5	ZF2				5.23	0.78	4.60	926	40

Symbols

MCA : Minimum Circuit Amperes (A)

kW : Fan Motor Rated Output (kW)

FLA : Full Load Amperes (A)

IFM : Indoor Fan Motor

PI : Maximum Power Input (W)

Note

- Voltage range
Units are suitable for use on electrical systems where voltage supplied to unit terminals is not below or above the listed range limits.
- Maximum allowable voltage unbalance between phases is 2%.
- MFA/MCA
 $MFA = 1.25 \times FLA$, $MCA = MFA / 1.1$
(If MFA is smaller than minimum standard value, Use minimum standard value in region for selecting circuit breaker.)
- Select wire size based on the MCA
- Instead of fuse, use Circuit Breaker.

9. Sound levels

9.1 Sound pressure level

Overall

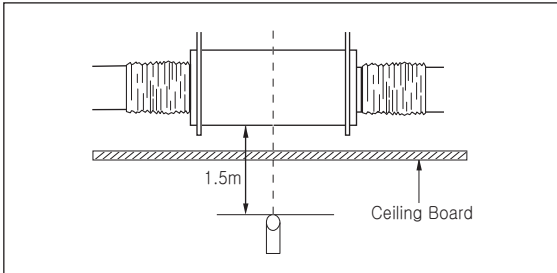

Note

1. Sound measured at some distance away from the center of the unit.
2. Data is valid at free field condition.
3. Reference acoustic pressure $0\text{dB} = 20\mu\text{Pa}$.
4. Data is valid at nominal operation condition.
Refer to the Model Specifications for nominal conditions (Power source and Ambient temperature, etc)
5. Sound levels can be increased in accordance with installation and operating conditions. (Static pressure mode, used air guide, Room target temperature setting, etc)
6. Sound level will vary depending on a range of factors such as the construction (acoustic absorption coefficient) of particular room in which the equipment is installed.
7. Sound pressure level is measured on the rated condition in the anechoic rooms by ISO 3745 standard.
Therefore, these values can be increased owing to ambient conditions during operation.

Model	Sound Pressure Level [dB(A)]		
	SH	H	L
LZ-H025GBA4	29	28	24
LZ-H035GBA5	35	32	26
LZ-H050GBA5	37	36	28
LZ-H080GBA5	40	36	32
LZ-H100GBA5	40	37	33
LZ-H150GBA5	43	39	35
LZ-H200GBA5	43	40	36

9. Sound levels

LZ-H025GBA4

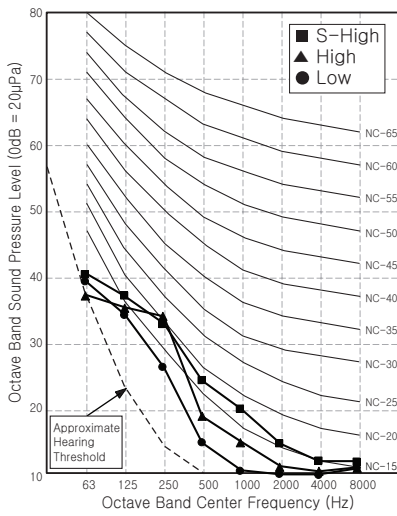

LZ-H035GBA5

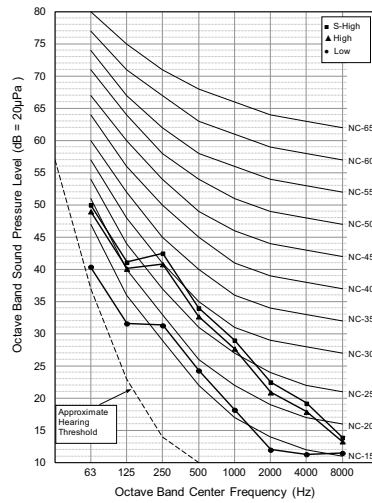

LZ-H050GBA5

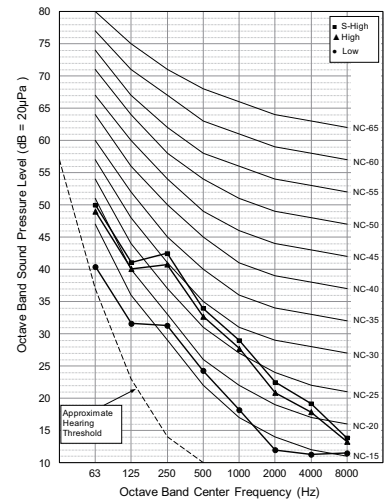

LZ-H080GBA5

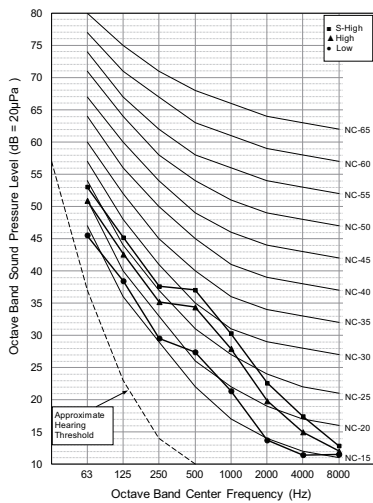

LZ-H100GBA5

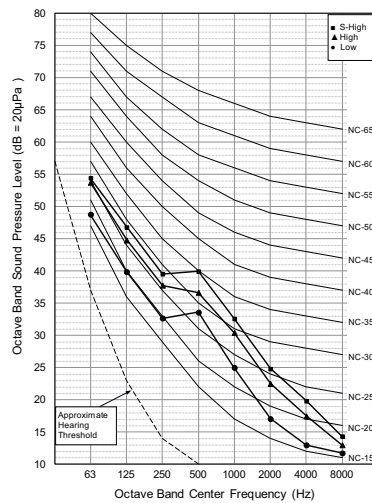

LZ-H150GBA5

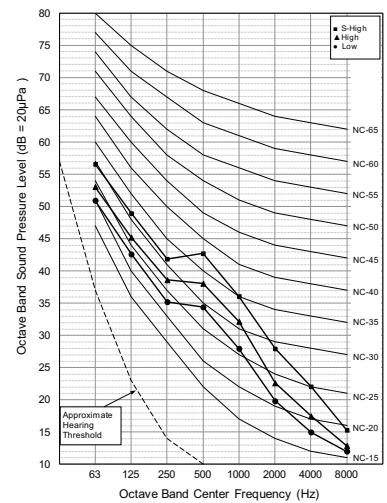

LZ-H200GBA5

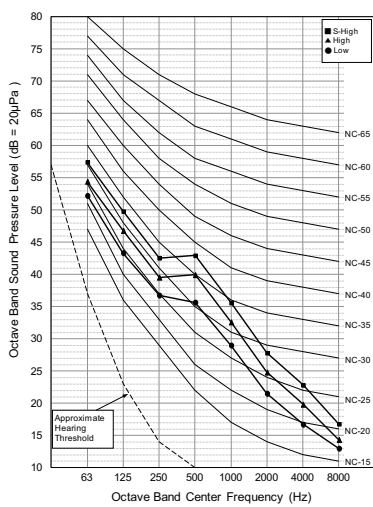

9. Sound levels

9.2 Sound power level

Note

1. Data is valid at diffuse field condition.
2. Data is valid at nominal operation condition.
Refer to the Model Specifications for nominal conditions(Power source and Ambient temperature, etc)
3. Sound level can be increased in static pressure mode or used air guide.
4. Sound level will vary depending on a range of factors such as the construction (acoustic absorption coefficient).
5. Reference acoustic intensity 0dB = $10E-6\mu W/m^2$
6. Sound power level is measured on the rated condition in the reverberation rooms by ISO 3741 standard.
Therefore, these values can be increased owing to ambient conditions during operation.

Model	Sound power level [dB(A)]		
	SH	H	L
LZ-H025GBA4	50	-	-
LZ-H035GBA5	53	50	42
LZ-H050GBA5	57	56	46
LZ-H080GBA5	56	53	47
LZ-H100GBA5	59	56	52
LZ-H150GBA5	59	56	50
LZ-H200GBA5	62	59	55

9. Sound levels

LZ-H025GBA4

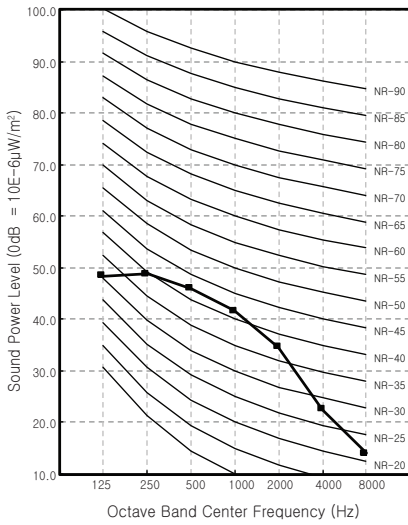

LZ-H035GBA5

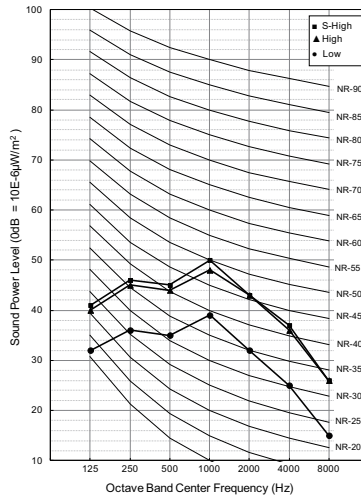

LZ-H050GBA5

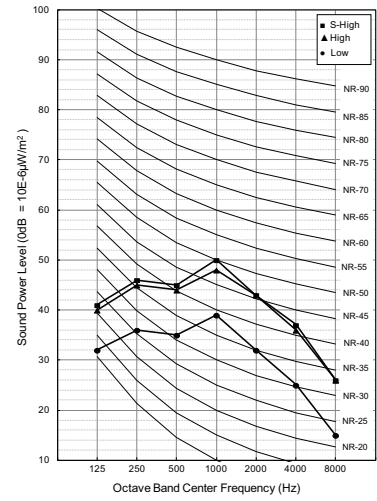

LZ-H080GBA5

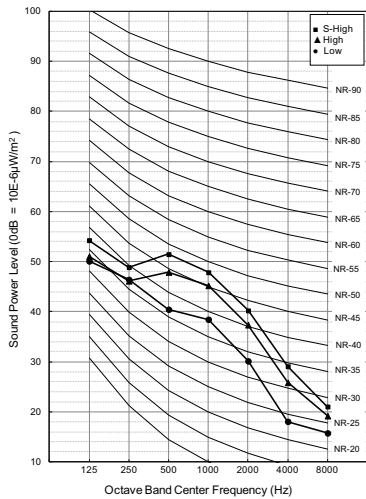

LZ-H100GBA5

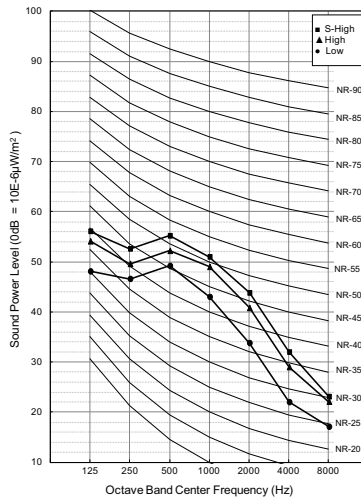

LZ-H150GBA5

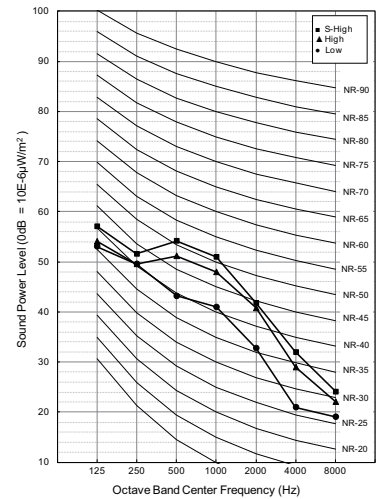

LZ-H200GBA5

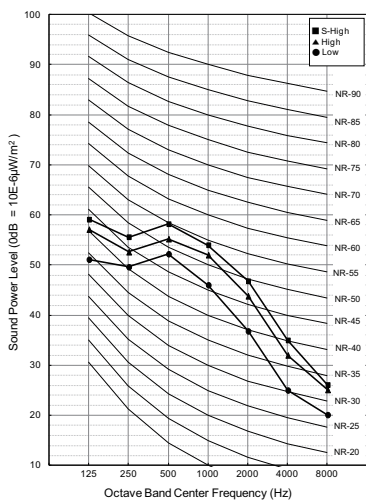

10. Installation

10.1 Typical Installation Map

■ LZ-H025GBA4 / LZ-H035GBA5 / LZ-050GBA5

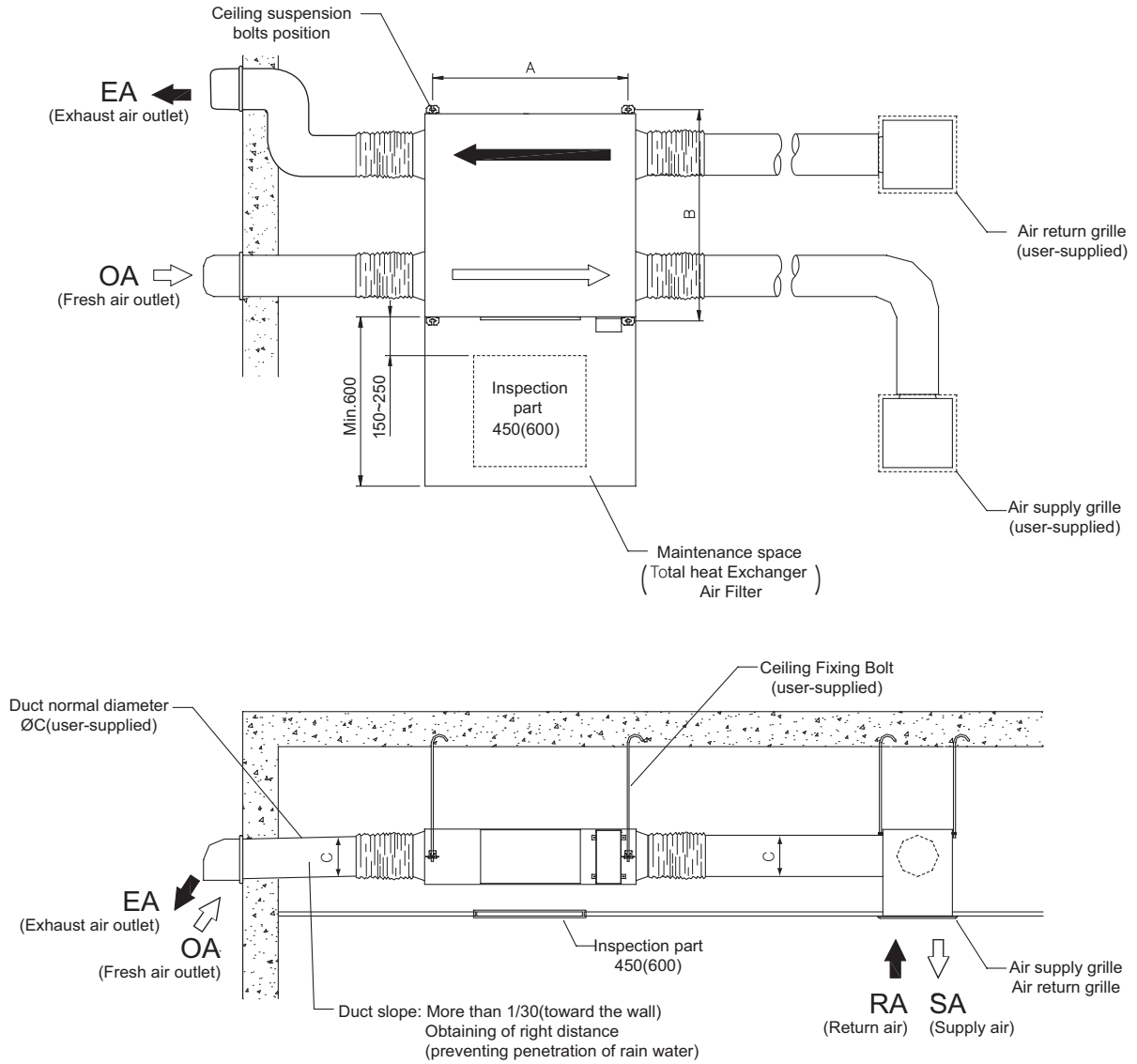

[Unit : mm]

Mode	A	B	C
LZ-H025GBA4 LZ-H035GBA5 LZ-H050GBA5	939	1,025	200

10. Installation

LZ-H080GBA5 / LZ-H100GBA5

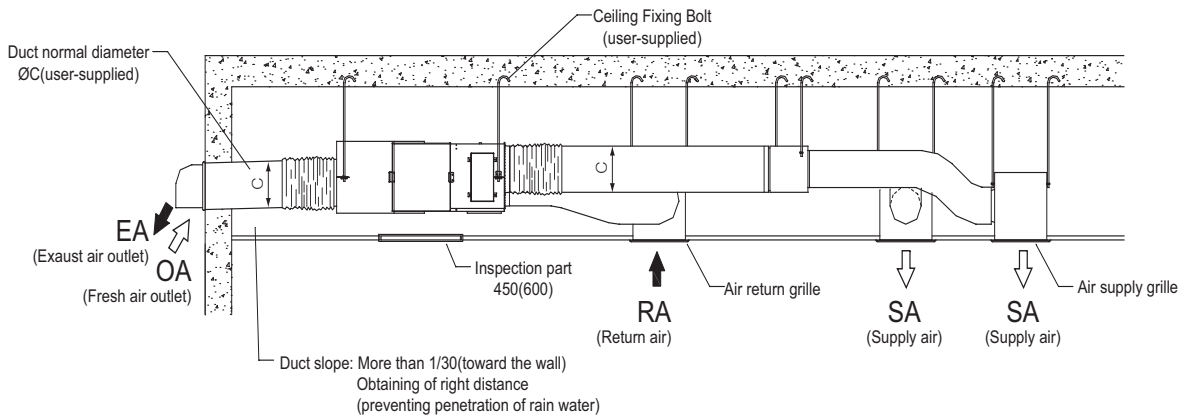
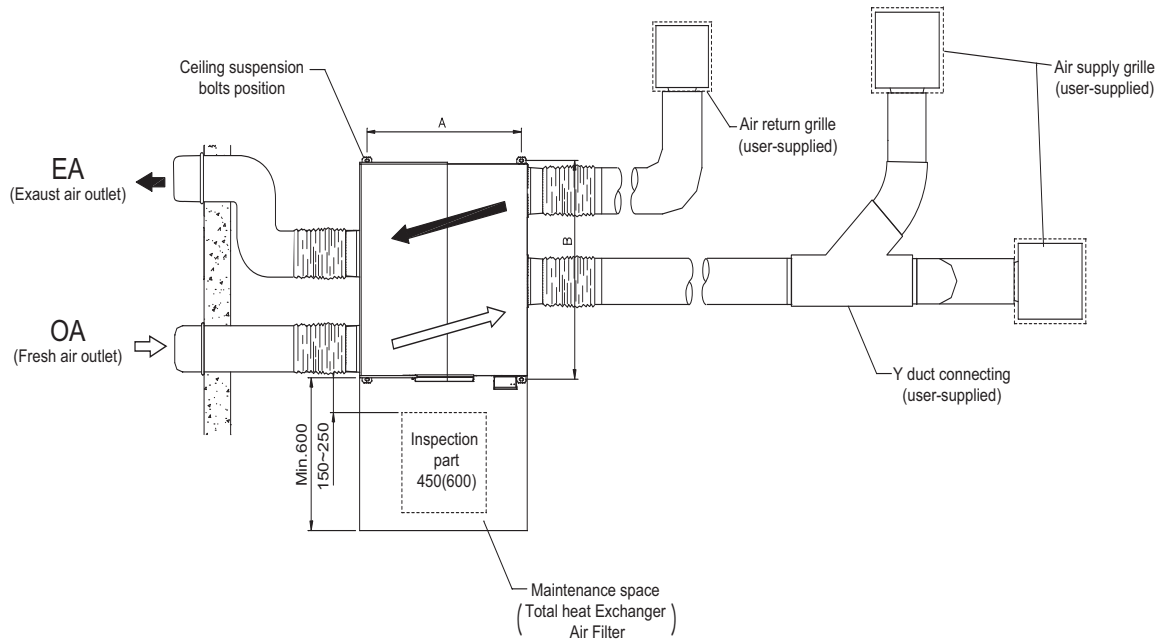

[Unit : mm]

Mode	A	B	C
LZ-H080GBA5	1,026	1,263	250
LZ-H100GBA5			

10. Installation

LZ-H150GBA5 / LZ-H200GBA5

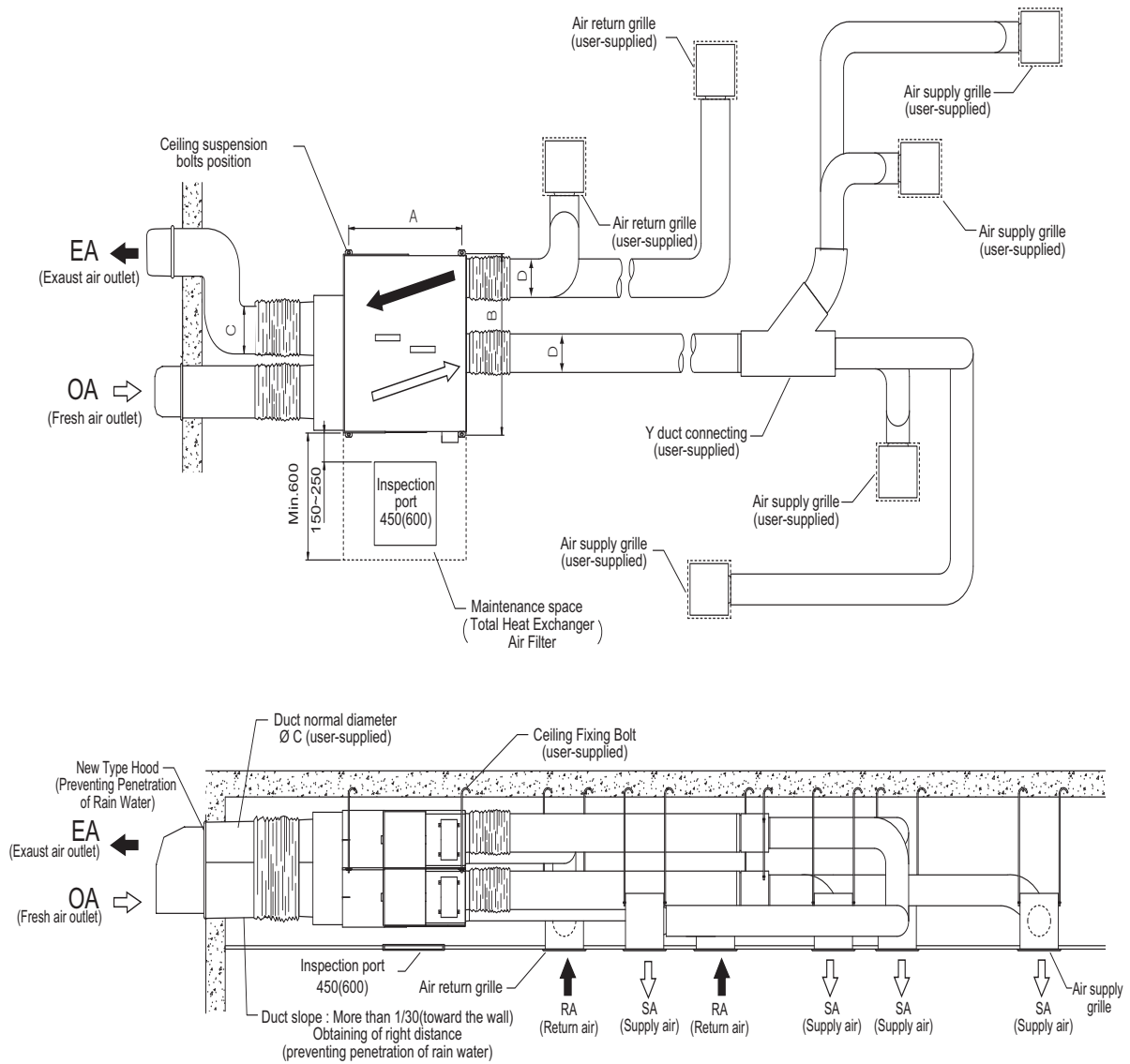

[Unit : mm]

Mode	A	B	C	D
LZ-H150GBA5	1,026	1,263	350	250
LZ-H200GBA5				

10. Installation

10.2 Installation

■ Installation of Main Body

Assembly of washer, Nut

Tighten the commercial washer nut (more than 21mm for the outside diameter of M10, to the commercial ceiling fixing bolt (M10) as shown in the figure.

- For the ceiling fixing bolt, perform work less than 50mm under the ceiling fixing bracket.

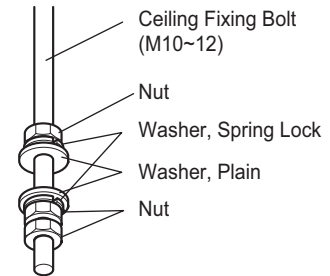

■ Connection of Duct

1. After securely connect the duct with the duct connection flange, wrap it with a commercial aluminium tape so that air cannot be leaked.
2. Adjust the duct from the ceiling so that no force is applied to the main body of the ventilation system.
3. Always use two ducts at the outdoor with the heat insulating material for prevention of dewing.

⚠ CAUTION

- Check that there are no foreign materials (paper, vinyl, etc) or cutoff powders in the duct before connecting the duct.
- Take care so that shock may not be applied to the damper plate within the main body when performing the duct connection work.
- It is recommended to perform adiabatic treatment even to the duct pipe at the indoor side where ambient temperature is expected when the main body of the ventilation system for cooling in summer.
- Take care so that work may not be performed as in the below figure. Otherwise, it may cause reduction of air volume or abnormal noise.

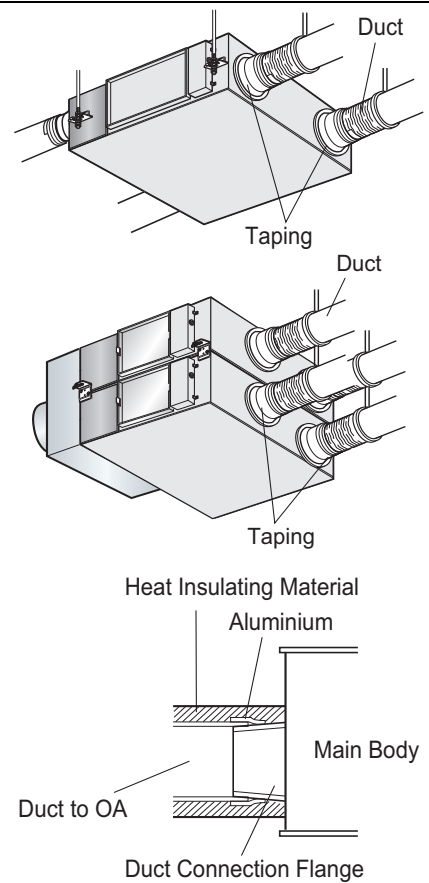
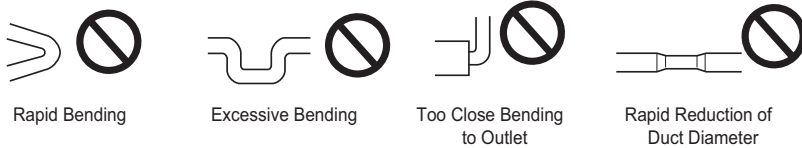

10. Installation

10.3 Wiring Connection

Method to Connect Power Cord

1. Release two screw and then open the cover of the control box.

- With reference to the above wiring diagram, accurately connect the main power cords into the terminal block.

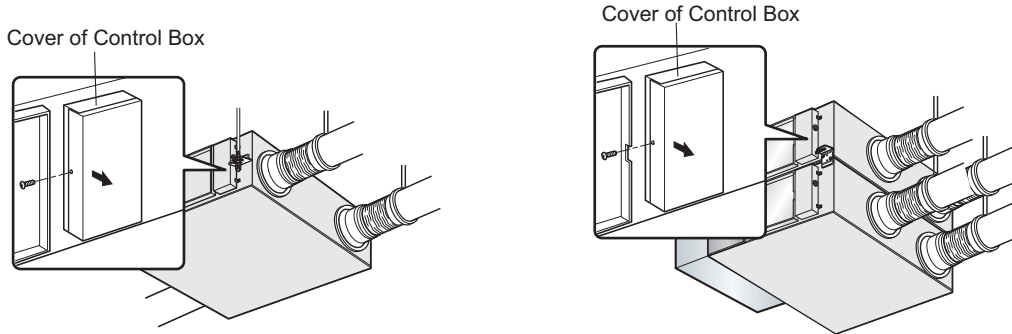

2. After inserting the power cord into the bushing, fully insert it into the terminal block for connection.

- Fix the power cords with the clamp.
- Make sure that the power cords may not be removed by pulling them.

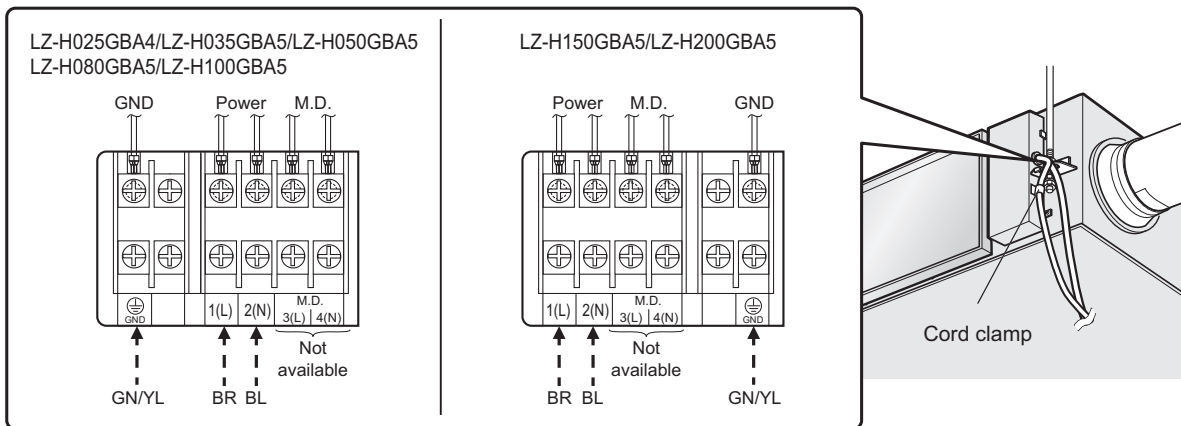

CAUTION

The power cord connected to the unit should be selected according to the following specifications.

WARNING

Indoor unit ground wires are required for preventing electrical shock accident during current leakage, Communication disorder by noise effect and motor current leakage (without connection to pipe).

10. Installation

10.4 M.D(Motorized damper) installation criteria

◆ Based on the M.D(Motorized Damper) installation

- Installed at the entrance of the outdoor duct(OA & EA) ventilation device.

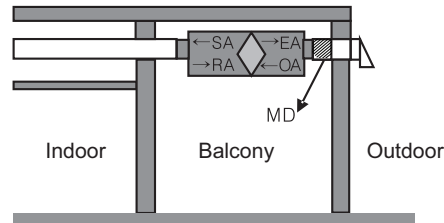

◆ Outdoor temperature Conditions for normal product operation : -10 °C ~ 40 °C

- If the temperature is outside the operating range of the product, there is a risk of condensation occurring inside the ventilation device.
- Do not install it in a humid place such as a bathroom.
- Install MD(Motorized Damper) to prevent external air inflow.
- Do not operate the ventilation system during rain or strong winds as water may flow into the indoors.

11. LCD Wired Remote Control

11.1 Operating Instruction (Accessory) - PREMTB100

◆ LG RS3 Standard Wired Remote Controller

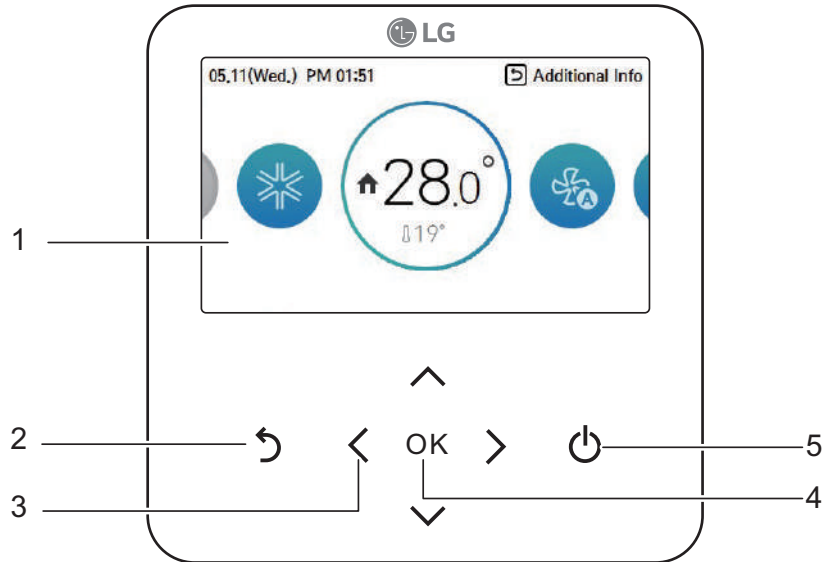

Functions (Button Descriptions)		
No.	Name	Functions
1	Operation display window	Operation and Settings status display
2	Back button	When you move to the previous stage from the menu's setting stage
3	Up/down/left/right button	When you change the menu's setting value
4	OK button	When you save the menu's setting value
5	On/Off button	When you turn ON/OFF the air conditioner

11. LCD Wired Remote Control

[Unit : mm]

11.1.1 Ventilation operating scene and ventilation operating method

This unit's remote controller can be installed with two types; Single Operation & Interlinked Operation

1. Single Operation

- It controls using the wired remote controller at a place where ventilation unit is connected only.

2. Interlinked Operation

- It controls using the wired remote controller at a place where the air conditioner indoor unit and the ventilation product are connected and installed at the same time.
- When the power is applied, the remote controller recognizes the product and operates normally.

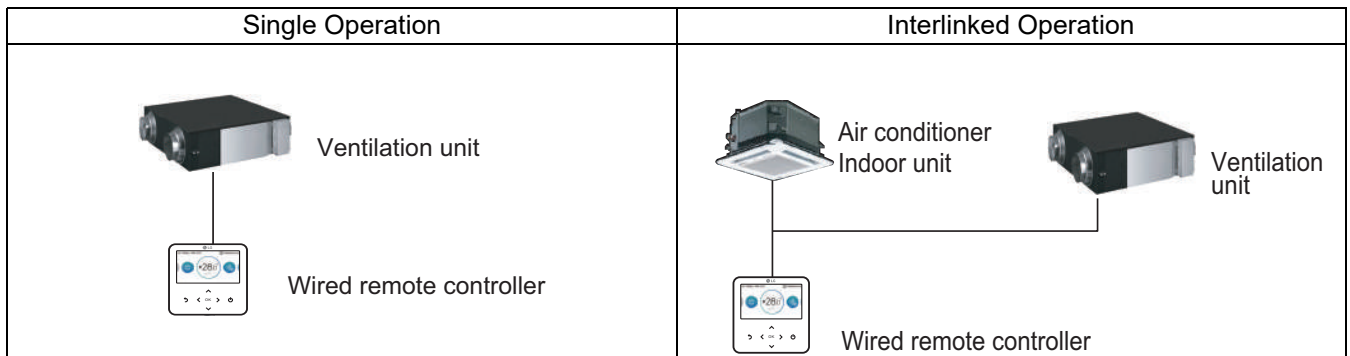

* The wiring method is the same as the air conditioner user manual.
 (Refer to the remote controller manualgroup control page contents)

11. LCD Wired Remote Control

11.1.2 Operation Control

■ On / Off

Single Operation

Air conditioner and ventilator will be turned on or off.

- Press On/Off button on the remote controller. It displays as the below figure.



< Air conditioner main screen >

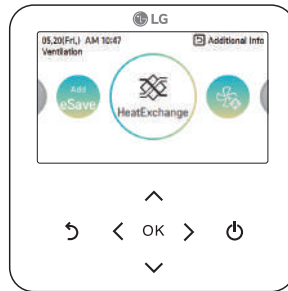

<General Ventilation main screen >



<Dx Ventilation main screen >

Interlinked Operation

It can only be used when the air conditioner is interlinked with ventilation product.

- Press (On/Off) button on the remote controller.
 - When you control the air conditioner and the ventilation product with one remote controller, the screen is displayed as in the below figure.
 - You can set the air conditioner by pressing [<(left)] button and pressing [OK] button to move to the air conditioner screen.
 - You can set the ventilation by pressing [>(right)] button and pressing [OK] button to move to the ventilation screen.

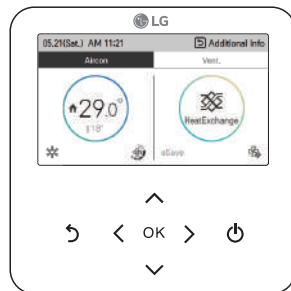

<Air conditioner mode >



<Ventilation mode >

* Ventilation product means general ventilation product and direct expansion ventilation product.

11. LCD Wired Remote Control

■ Operation

- In the main screen, press [**<** , **>**(left/right)] button to select the operation mode category, and press [**^** , **v**(up/down)] but-ton to set the operation mode.

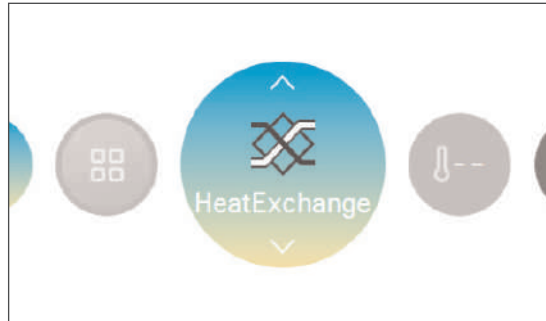

◆ Ventilation operation mode (general / direct expansion ventilation product)

Mode	Description
Auto	It automatically operates in the optimum ventilation mode by measuring the indoor/outdoor air temperature of the ventilation system.
Heat Exchange	It is the mode of ventilation with both supply/discharge through the heat exchanger.It is adequate to use in summer/winter where the indoor/outdoor temperature difference is big.
Bypass	It is the ventilation where the exhausted air is ventilated without going through the exchanger.It is adequate to use in spring/fall or when the indoor contamination is severe.

◆ Air conditioner operation mode (direct expansion ventilation product)

Mode	Description
Cool	It cools down the room to desired temperature.
Heat	It provides warm wind to the room.
Auto	It automatically provides the appropriate fan speed based on the temperature of the room.
Stop	It stops the product's air conditioner operation.

Note

- Some products may not support some operation modes.
- The air conditioner operation mode is composed separately from the ventilation operation mode.

11. LCD Wired Remote Control

■ Fan Speed Control

- In the main screen, press [$<$, $>$ (left/right)] button to select the fan speed category, and press [\wedge , \vee (up/down)] button to set the fan speed.
- It circulates in the order of 'low \leftrightarrow high \leftrightarrow power \leftrightarrow auto'.



* The auto Fan can be used only when the air contamination (CO2) sensor is installed.

■ Returning to the screen

- In the main screen, after moving to the category by pressing [$<$, $>$ (left/right)] button, if there is no remote controller operation, after 10 seconds, it returns to the main screen basic position. (basic position: indoor temperature display part)
- In the screens except the main screen, if there is no remote controller operation for 1 minute, it moves to the mainscreen.

11. LCD Wired Remote Control

11.1.3 Additional Function

■ Fast / Energy saving ventilation mode

It is a function to operate ventilation function more efficiently through the ventilation additional functions, fast / energy saving settings.

- In the main screen, press [**<** , **>**(left/right)] button to select the additional operation category, and press [**^** , **v** (up/down)] button to set the additional operation.

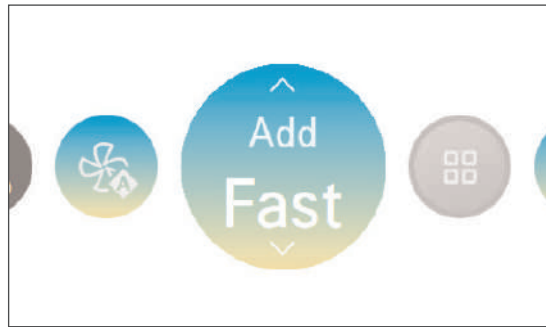

Additional Operation	Description
Fast	It ventilates in short period of time. It is the function to operate the ventilation function more efficiently through the express setting which is an additional operation of the ventilation product.
Energy saving	It performs the energy saving function while ventilating efficiently.

Note

- The general ventilation and the direct expansion ventilation's additional operation are the same.
- The ventilation product's additional functions (air cleaning / heater / humidification / fan auto) setting methods are the same as the air conditioner.

11. LCD Wired Remote Control

■ Humidification operating mode

It is the function to activate the humidifier installed in the product when the indoor air is dry.

Additional function setting list

- In the menu screen, press [**<**, **>**(left/right)] button to select the additional function category, and press [**OK**] button to move to the additional function setting list screen.
- In the additional function setting list screen, if you press [**^**, **v** (left/right)] button, you can turn on/off the corresponding additional function.

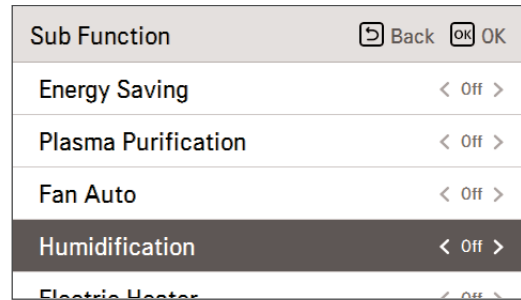
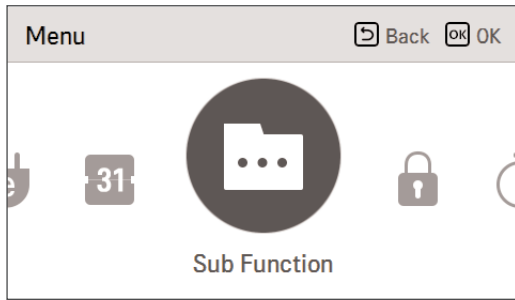

Additional function screen

- In the main screen, press [**Back**] button to move to the monitoring/additional function screen, and press [**<**, **>**(left/right)] button to move to the additional function screen.
- In the additional function screen, select the additional function category to set, and if you press [**OK**] button, you can turn on/off the corresponding function.

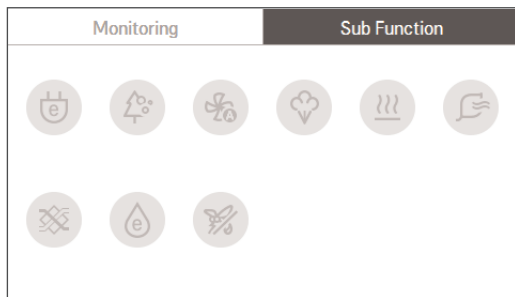

Note

- Humidification function might not be operated at the partial product.
- When you choose heating operating mode, humidity mode is automatically selected.

11. LCD Wired Remote Control

■ Temperature setting / Room Temperature check

You can easily control to the desired temperature and check the current indoor temperature.

- In the main screen, press [$<$, $>$ (left/right)] button to select the desired temperature category, and press [\wedge , \vee (up/down)] button to set the desired temperature.
- In the cooling, heating, and AI/auto mode, the desired temperature control is possible.

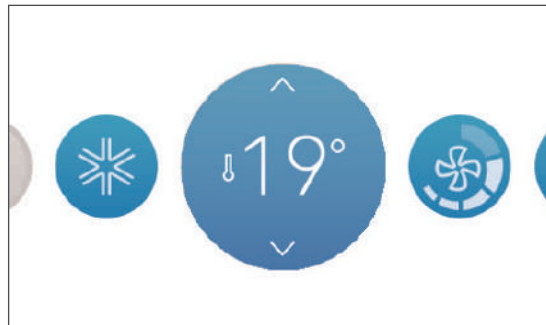

Mode	Description
Cool	If the desired temperature is higher than the indoor temperature, the cooling is not performed. Set the desired temperature lower than the indoor temperature. You can select in the range of 18°C ~ 30°C (16°C ~ 30°C).
Heat	If the desired temperature is lower than the indoor temperature, the heating is not performed. Set the desired temperature higher than the indoor temperature. You can select in the range of 16°C ~ 30°C.
AI / Auto	For cooling/heating product, you can select in the range of 18°C ~ 30°C. For cooling exclusive product, you can select Hot, A little hot, Adequate, A little Cold, and Cold.

Note

- 5°C is proper for the difference between room and outside temperature.
- Ventilation unit can't make room temperature reach to the set temperature because the air is supplied from outdoor.
- General ventilation in single operation cannot control room temperature. If this is needed, do not install the ventilation unit alone, but rather install another indoor unit.

11. LCD Wired Remote Control

11.1.4 Locking Setting

It is the function to lock the button operation of the remote controller so that children or other persons cannot use it without permission.

It is the function to limit the desired temperature range that can be set in the wired remote controller.

- In the menu screen, press [\leftarrow , \rightarrow (left/right)] button to select “lock setting” category, and press [OK] button to move to the lock setting list screen.
- In the lock setting list, if you press [\wedge , \vee (up/down)] button, you can turn on/off the corresponding lock function.

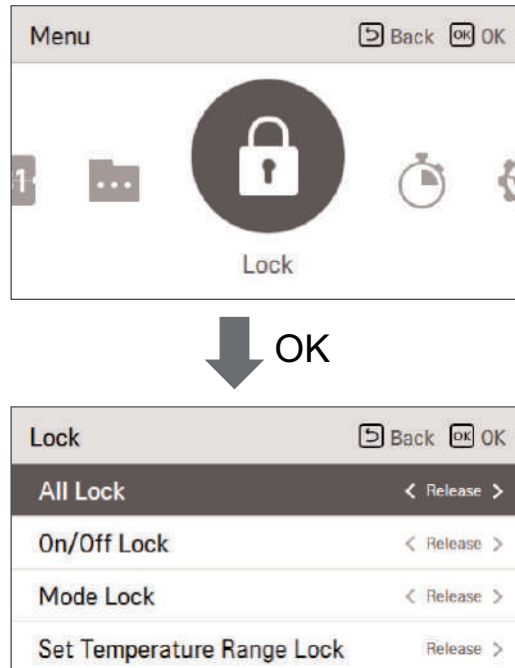

Lock	Description
All lock	It locks all button operation of the remote controller.
On/ Off lock	It locks the On/Off button operation of the remote controller.
Mode lock	It locks the operation mode button operation of the remote controller.
Temperature range lock	It is the function that can limit the range of the desired temperature that can be set in the wired remote controller. It works as soon as you press the [\wedge , \vee (up/down)] Lower limit: 16°C~30°C Upper limit: 18°C~30°C

Note

- In the central controller, when the central control temperature range lock is set, the wired remote controller’s temperature lock setting is cleared.
- The temperature change by external equipment is reflected regardless of the remote controller temperature range lock.

11. LCD Wired Remote Control

11.1.5 Timer Setting

■ Timer entrance and setting method

- In the menu screen, press [**<**, **>**(left/right)] button to select the timer category, and press [OK] button to move to the timer setting list screen.
- In the timer setting list screen, press [**^**, **v** (up/down)] button to select the timer to set, and press [OK] button to move to the detail screen.
- After setting the value, when you press [OK] button, the timer is activated.
- After setting the value, if you press [Back] button, the changed value will not be reflected.

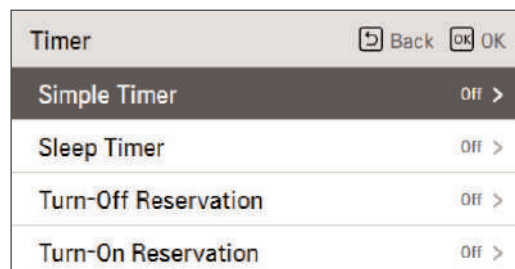
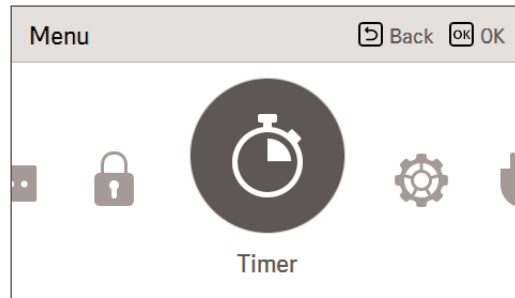

11. LCD Wired Remote Control

Simple Timer

You can easily set the timer in the range of 1~7 hours in the units of 1 hour.

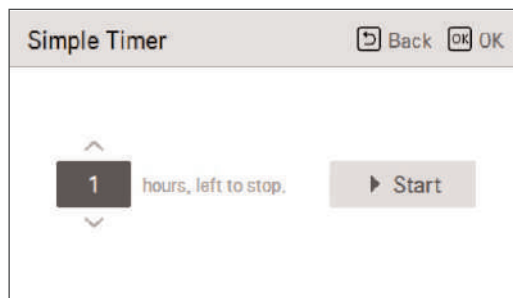
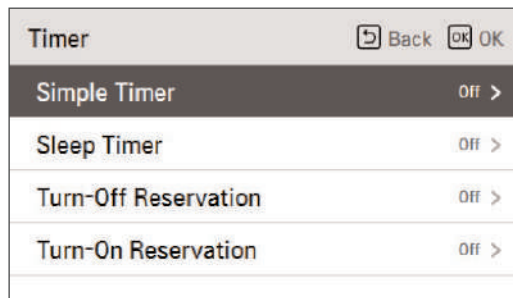

Note

- If the product operation is On, the easy timer turns off the operation after the corresponding time.
- If the product operation is Off, the easy timer turns on the operation after the corresponding time.
- If the easy timer operation is turned On/Off before the timer operation, the set timer will be cleared.

11. LCD Wired Remote Control

■ Sleep Timer

Sleep timer is the function to operate the air conditioner in sleep mode before going to sleep for certain hours and stop the operation.

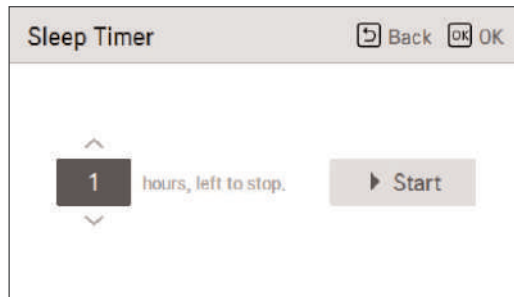
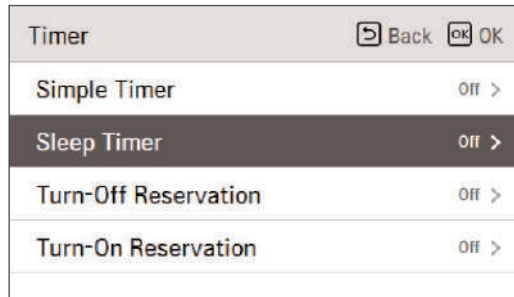

Note

- You can set the sleep timer while the product is in operation.
- If the sleep timer operation is turned On before the timer operation, the set timer will be cleared.

11. LCD Wired Remote Control

■ Turn Off Reservation

The product is automatically turned Off at the set timer time.

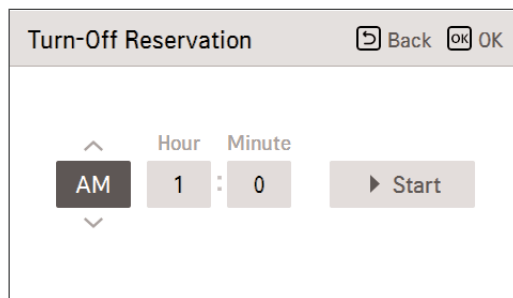
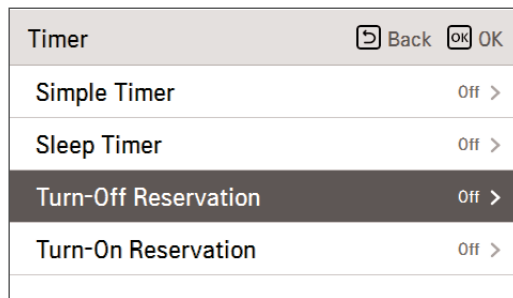

Note

- Even if the Turn-off Reservation operation is turned On/Off after the setting and before the timer operation, the set timer is not cleared.

11. LCD Wired Remote Control

■ Turn On Reservation

The product is automatically turned On at the set timer time.

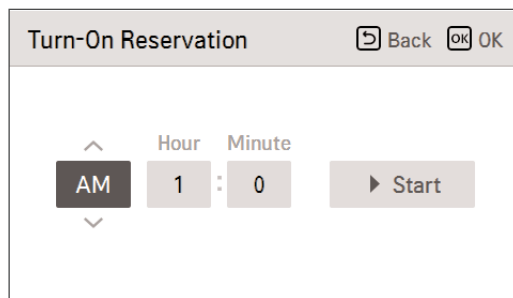
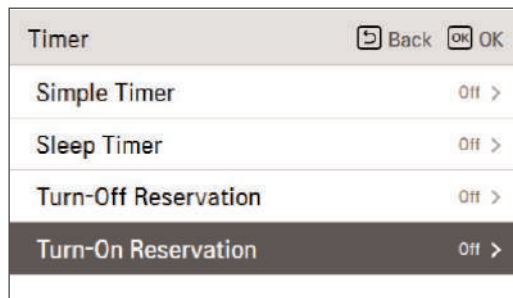

Note

- Even if the Turn-on Reservation operation is turned On/Off after the setting and before the timer operation, the set timer is not cleared.

11. LCD Wired Remote Control

11.1.6 Schedule Setting

■ How to enter schedule

- In the menu screen, press [**<**, **>**(left/right)] button so select the schedule category, and press [**OK**] button to move to the schedule setting list screen.
- In the schedule setting list screen, press [**^**, **v** (up/down)] button to select the menu to set, and press [**OK**] button to move to the detail screen.

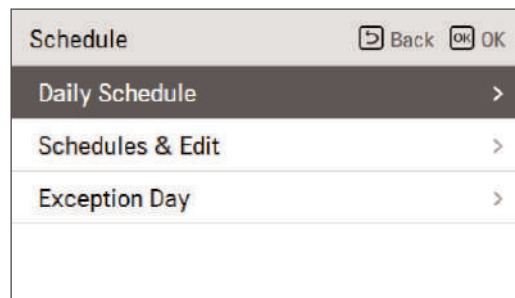
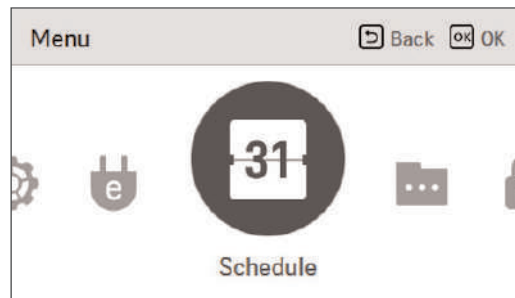

11. LCD Wired Remote Control

■ Daily schedule

It is the function that can check the status of the timer (schedule) saved in the remote controller.

- In the schedule list, select the daily schedule status category, and press [OK] button to move to the detail daily schedule status screen.
- You can use the remote controller's [\leftarrow , \rightarrow (left/right)] button to check the timer information of other dates.

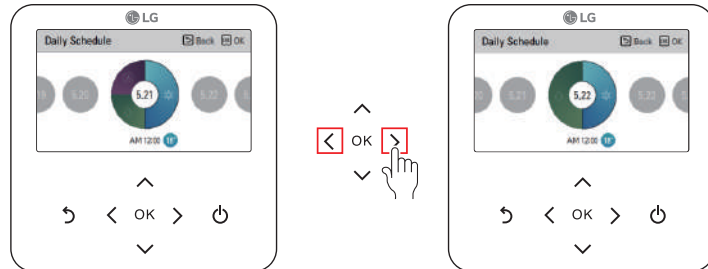

- You can use the remote controller's [\wedge , \vee (up/down)] button to check the corresponding date's other timer information.

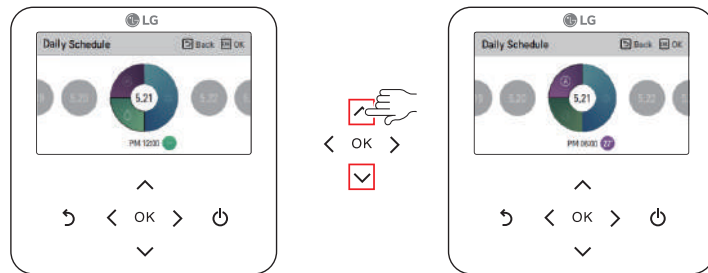

- Select the timer information, and press [OK] button to move to the corresponding timer's edit screen.

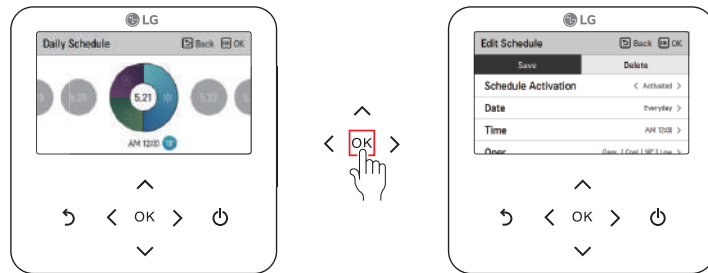

11. LCD Wired Remote Control

Schedule & Edit

It is the function that can check the status of the timer (schedule) saved in the remote controller.

- In the schedule list, select the daily schedule status category, and press [OK] button to move to the daily schedule status detail screen.
- You can use the remote controller's [, >(left/right)] button to check other date's timer information.

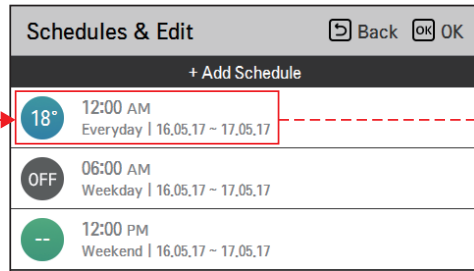

You can check the settimer's operation information(operation On/Off, operation mode, desired temperature), timer time, period, and day of week.

- You can edit the saved schedule's timer information.
 - Select the schedule to edit using [^, v (up/down)] button, and press [OK] button to move to the edit screen.

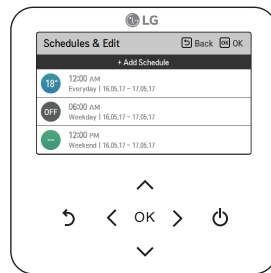

- Select the timer information, and press [OK] button to move to the corresponding timer's edit screen.

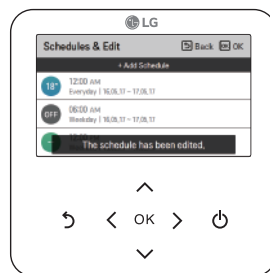

< If schedule is changed >



< If schedule is deleted >

11. LCD Wired Remote Control

■ Schedule & Edit - Add Schedule

- Description of each stage in Add schedule



Stage 1. Period setting

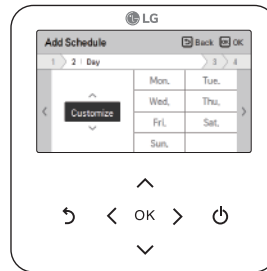

Stage 2. Day of week setting



Stage 3. Time setting

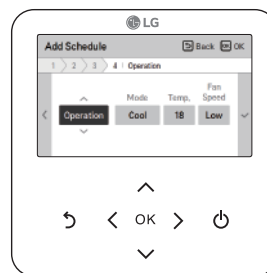

Stage 4. Operation setting



Add schedule is completed

Category	Description
Stage 1	It sets the period to perform the timer.
Stage 2	It sets the day of week to perform the timer. - You can select 'Everyday / Weekend / Weekdays / Individual selection'.
Stage 3	It sets the start time for the timer.
Stage 4	It sets the timer operation information. - If 'Stop' is selected, you cannot set the mode / temperature / fan speed.

* When stages 1~4 are completed, along with the message of 'schedule is added', it moves to View and edit schedule screen.

11. LCD Wired Remote Control

■ Exception day

It is the function to automatically stop the operation on the set timer day.

- In the schedule list, select the exception day category, and press [OK] button to move to the Exception day designation detail screen.
- In the exception day, you can check, and add/change/delete the exception day information saved in the remote controller.
 - To add an exception day, in the Exception day registration detail screen, designate year/month/day, and press [OK] button to save the Exception day.
 - Select the Exception day to edit using [^, v (up/down)] button, and press [OK] button to move to the edit screen.

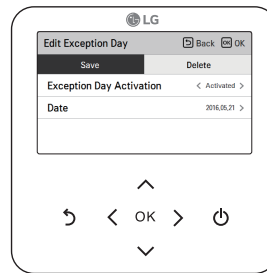
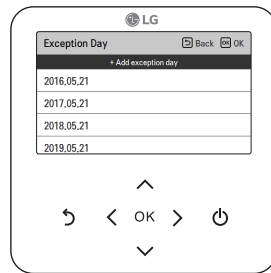

- In the exception day edit screen, you can check, delete/change the corresponding exception day's setting contents.
- When you change the exception day information, you need to save it after the change.

11. LCD Wired Remote Control

11.2 Operating Instruction (Accessory) - PREMTB001 / PREMTBB01

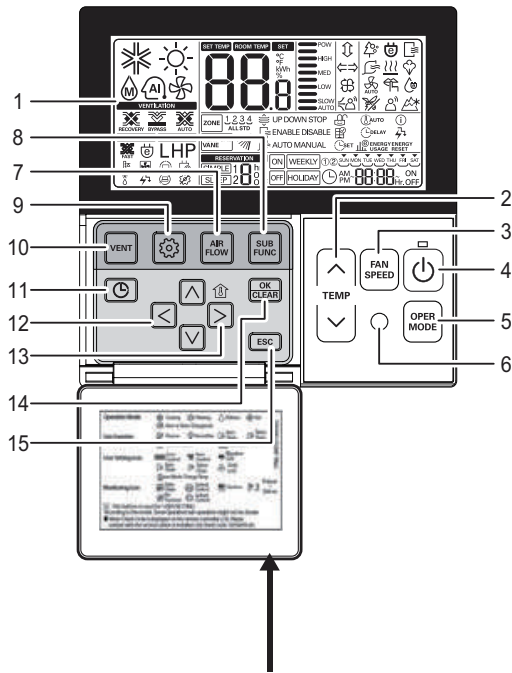

Please attach the inform label inside of the door.
Please choose proper language depend on your country.

1. OPERATION INDICATION SCREEN
2. SET TEMPERATURE BUTTON
3. FAN SPEED BUTTON
4. ON/OFF BUTTON
5. OPERATION MODE SELECTION BUTTON
6. WIRELESS REMOTE CONTROLLER RECEIVER
 - Some products don't receive the wireless signals.
7. AIR FLOW BUTTON
8. SUBFUNCTION BUTTON
9. FUNCTION SETTING BUTTON
10. VENTILATION BUTTON
11. RESERVATION
12. UP, DOWN, LEFT, RIGHT BUTTON
 - To check the indoor temperature, press  button.
13. ROOM TEMPERATURE BUTTON
14. SETTING/CANCEL BUTTON
15. EXIT BUTTON

* Some functions may not be operated and displayed depending on the product type.

* Some functions may not be operated and displayed depending on the product type.

11. LCD Wired Remote Control

11.2.1 Ventilation operating scene and ventilation operation method

1. Control using remote controller where air conditioner indoor unit and the ventilation product is installed at the same time.

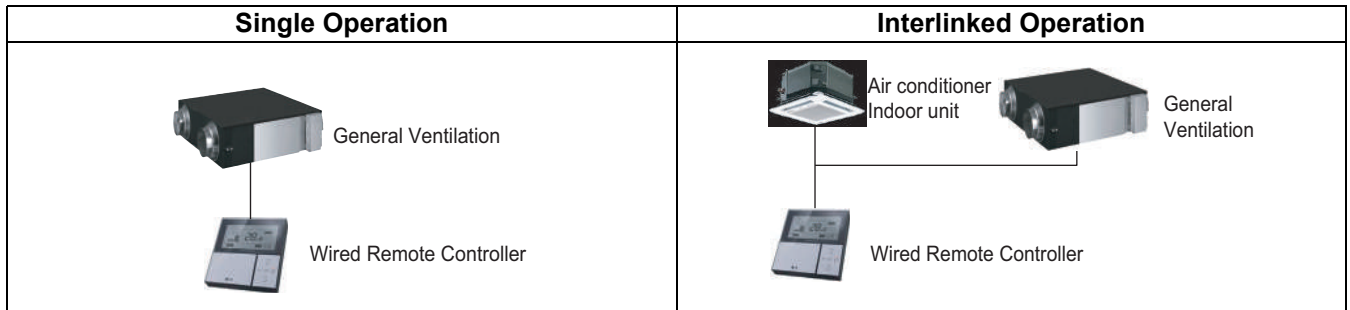

2. Press 'Ventilation' button on the wired remote controller and enter Ventilation control mode to check the operation of ventilation product.

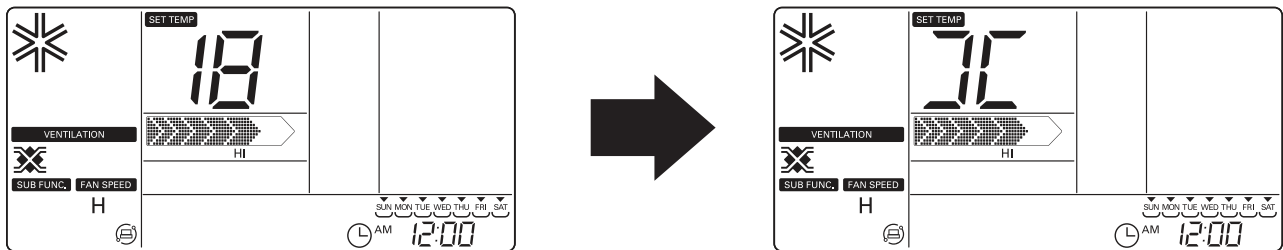

3. To convert back to air conditioner mode, press 'Ventilation' button at the ventilation mode.

- If no button pressed for 15 seconds or more at ventilation mode, it automatically converts back to air conditioner mode.
- Ventilation product represent general ventilation product and direct expansion ventilation product.



11. LCD Wired Remote Control

11.2.2 Interlinked operation with general ventilation

It is used when air conditioner is interlinked with ventilation product.

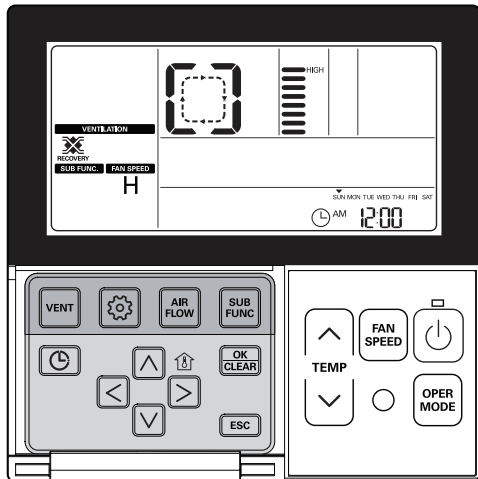
It is a function that cools and refreshes indoor air using the ventilation product at the same time operating the air conditioning function.



Ventilation interlinked operation	
<p>1 Press VENT button on the remote controller control panel. - It is only used when air conditioner and general ventilation is interlinked.</p>	
<p>2 Pressing 'Start/Stop' button at ventilation mode will start ventilation.</p>	
<p>3 Pressing OPER MODE button will change the ventilation operation mode. Pressing operation selection button will change the mode in the order of 'heat exchange → normal → automatic' <input checked="" type="checkbox"/> It only displays on the remote controller display when it is in ventilation mode, and it displays the desired temperature when it returns to air condition mode.</p>	
<p>4 Pressing FAN SPEED button in general ventilation mode will change airflow speed. Pressing airflow speed button will change the mode in the order of 'low → high → power'. If CO₂ sensor is installed, it can select from 'low → high → power → auto'.</p>	
<p>5 Changing back to air conditioner mode 1) Automatic conversion : when no button is pressed for 15 seconds or longer, it automatically converts back to air conditioner mode. 2) Manual conversion : pressing VENT button in ventilation mode will manually convert.</p>	





11. LCD Wired Remote Control

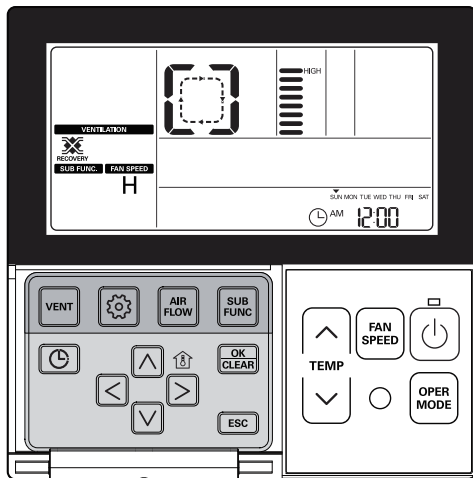

11.2.3 Ventilation mode manually convert method

It is a function to cool and refresh the indoor air using general ventilation product.





Ventilation single operation

- Press  button on the remote controller. 
- Pressing  button will change the ventilation mode. 

Ventilation mode	Remote controller display	Contents
Heat exchange		Circulate indoor air without loss of heat
Normal		Directly circulate indoor air without going through heat exchanger
Automatic	AU	Circulate indoor air with automatically comparing indoor and outdoor air

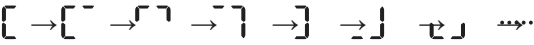
In the case of heat exchange mode, the display is shown as below.



- Pressing  button will change the strength of the wind
 - Pressing the button can select from 'low → high → power'.
 - If CO₂ sensor is installed, it can select from 'low → high → power → auto'.



11. LCD Wired Remote Control

11.2.4 Fast / Energy saving ventilation mode

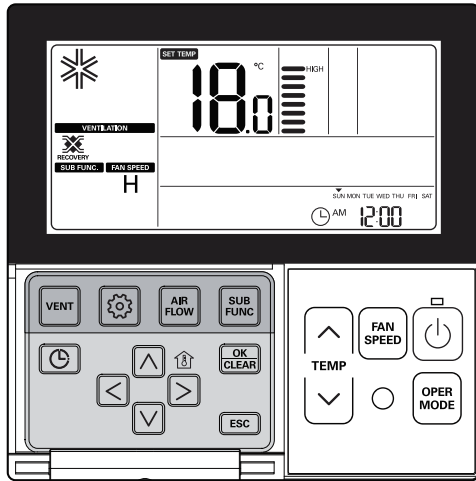

It is a function to operate ventilation function more efficiently through the ventilation additional functions, fast /power saving settings.

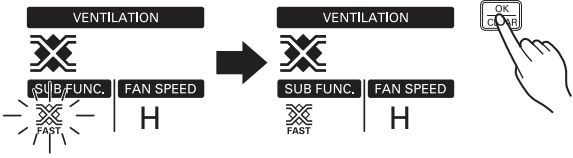

Fast : ventilates fast

- Press **SUB FUNC.** button in ventilation mode. - It converts in the order of 'fast → power saving' in ventilation mode. 
- 'Fast' is blinking on the display, and pressing **OK CLEAR** button will stabilize 'fast' icon, and the function is set. 
- Pressing **ESC** button will exit the settings. 

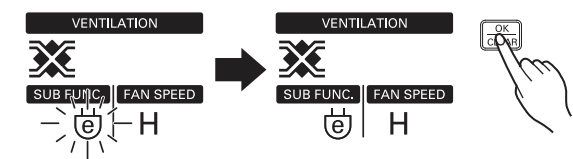
Power saving : efficiently ventilates and performs power savings.

- Press **SUB FUNC.** button in ventilation mode. - It converts in the order of 'fast → power saving' in ventilation mode. 
- 'Power saving' is blinking on the display, and pressing **OK CLEAR** button will stabilize 'power saving' icon, and the function is set. 
- Pressing **ESC** button will exit the settings. 
 - General ventilation and direct expansion ventilation have the same additional functions.
 - Ventilation/heater/humidifier additional function settings are the same as air conditioner.

11. LCD Wired Remote Control

11.2.5 Ventilation Product Function Setting

■ Delay Time Setting

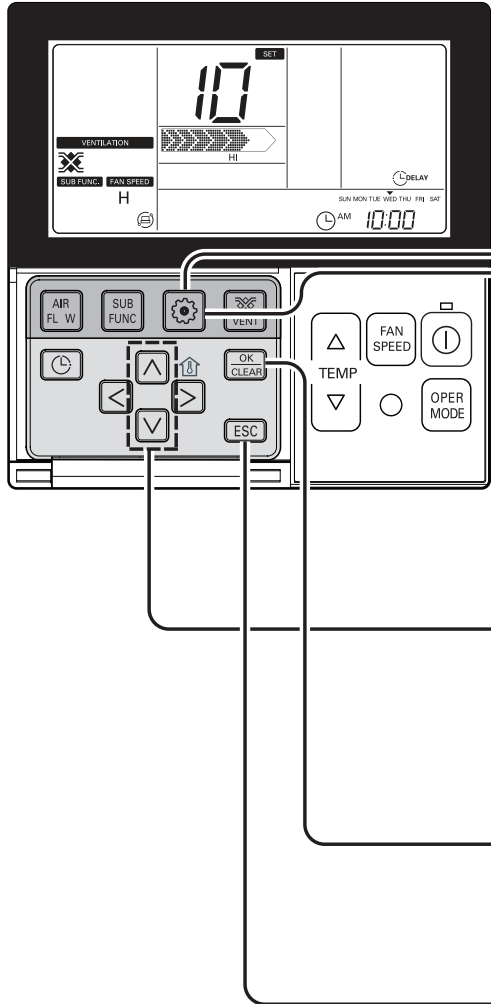



Delay Time : It operates after delay time in ventilation operation.

1 Press  Settings button.

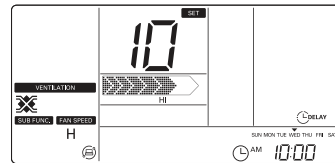

2 Pressing  button repeatedly will move to the delay time menu. Then delay time icon is displayed, and the delay time blinks at the temperature display area.



3 Pressing   button will change the delay time settings.
 * Boundary of delay time settings : 00 ~ 60 minutes (in the units of 1 minutes)

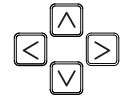

4 When the desired delay time is displayed, press  button to finish the settings.



5 Pressing  button when the setting is finished.









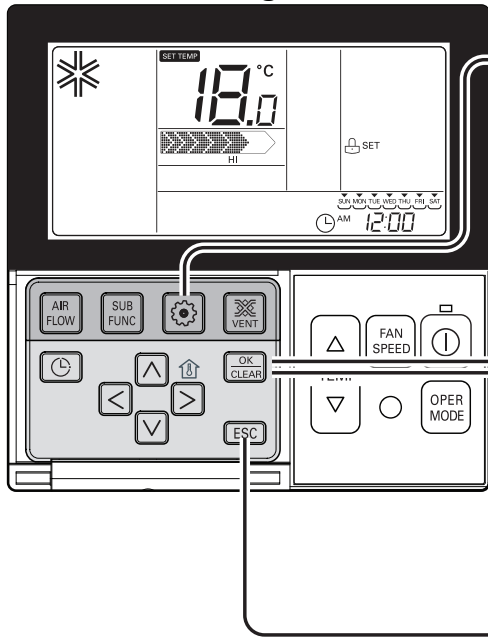

* If no button input for 1 minute after the setting, it exists the settings mode automatically. When exiting without pressing set button, the manipulated value is not reflected.



11. LCD Wired Remote Control







Child Lock Setting

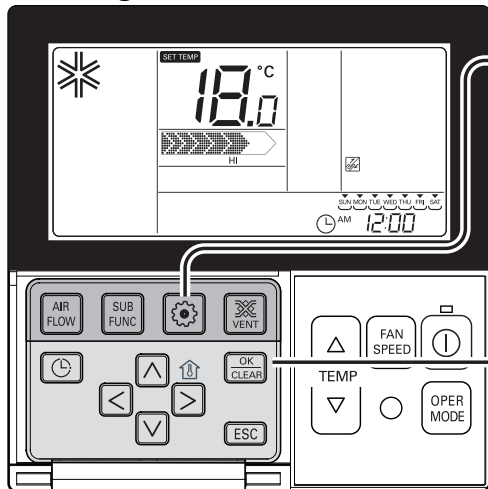

- 1 Press  button repeatedly until the  is flashing. 
- 2 If moving to 'setup' icon area by using   button, 'setup' icon blinks, and child lock function is setup if pressing  button at that time. 
- 3 When cancelling lock function, if moving to 'cancel' icon by pressing   button and then, pressing  button, child lock function is cancelled.
- 4 Press  button to exit.
 - * After setup, it automatically gets out of setup mode if there is no button input for 25 seconds.
 - * When exiting without pressing set button, the manipulated value is not reflected.

Filter Sign Clear



- 1 Press  button repeatedly until the  is flashing. 
- 2 When the  is flashing, press the  to clear this display 

- When filter is covered by dust, it will reduce cooling/heating efficiency and accumulate more electric power. Therefore, do clean the filter whenever cleaning time is expired.
- Filter cleaning indication is automatically cancelled without the separate cancellation after certain period of time.

11. LCD Wired Remote Control

[Unit : mm]

11.2.6 Changing Current Time

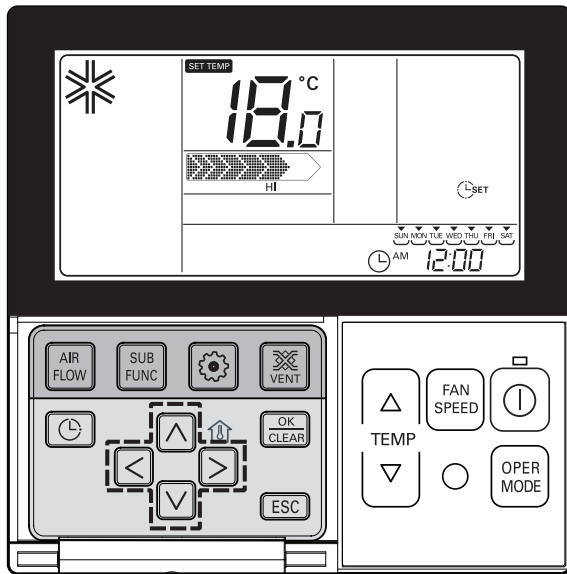

1 Please press function setup button. If pressing function setup button repeatedly, it moves to time setup menu. 'Time setup' icon is indicated at that time and date blinks at current time indication area.
Ex) Changing Current Time as 'Monday / AM 10:20'.

2 Press key to adjust the current day.
SUN MON TUE WED THU FRI SAT

3 Press key to move to AM/ PM setting mode (the 'AM/ PM segment will flash').
AM 12:00

4 Setting AM/ PM value by pressing button.

5 Press button to move to 'Hour' setting mode. (the 'Hour' segment will flash)



6 Setting Hour value by pressing button.



7 Press button to move to 'Minute' setting mode. (the 'Minute' segment will flash)



8 Setting Minute value by pressing button.



9 Press button to finish.



10 In the process, press button to release and exit from from setting mode.

(In case of exit with incomplete information, it will return to the precious setting)

* When exiting without pressing set button, the manipulated value is not reflected.

11. LCD Wired Remote Control

11.2.7 Ventilation Product Reservation Setting



■ Simple Reservation

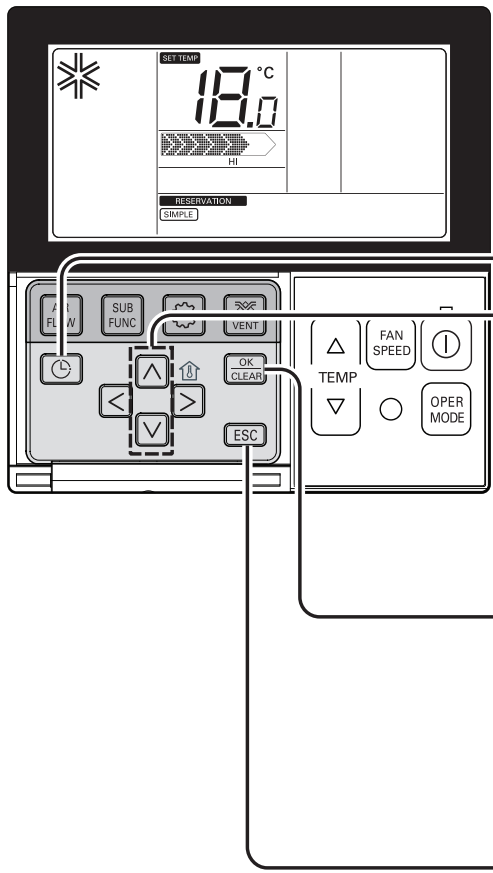

You can set the reservation conveniently in the units of 1 hour from 1 hour to 7 hours.



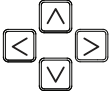

The diagram shows the control panel of the ERV. The LCD screen displays '18.0 °C' and 'RESERVATION SIMPLE'. The control panel has buttons for 'A FL W', 'SUB FUNC', 'VENT', 'TEMP', 'FAN SPEED', 'OPER MODE', 'OK CLEAR', 'ESC', and directional arrows. Callouts from the text box point to the 'RESERVATION SIMPLE' segment on the screen, the 'TEMP' buttons, the 'OK CLEAR' button, and the 'ESC' button.

- 1** Press  button to enter the Programming mode.
(the **SIMPLE** segment flashing)

Ex) Setting Simple Reservation time as '3'.
- 2** Press   button to adjust reservation time.

 
- 3** Press  button to finish setting.

- 4** Press  button to exit.

 - * After setup, it automatically gets out of setup mode if there is no button input for 25 seconds.
 - * When exiting without pressing set button, the manipulated value is not reflected.

11. LCD Wired Remote Control

■ Sleep Timer

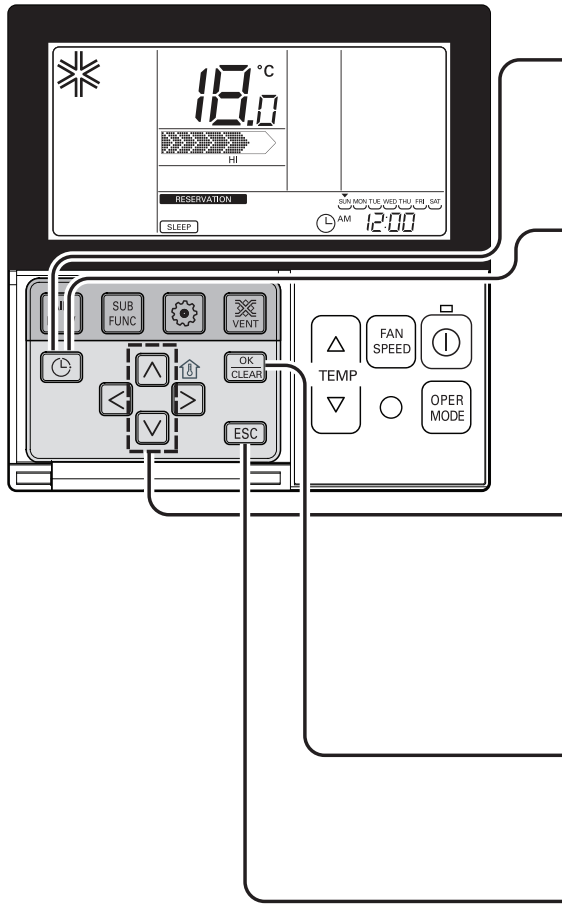

Sleep Reservations : Sets to operate ventilation lightly during the sleep.

1 Press button to enter the reservation settings mode.

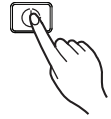

2 Press button again to move to Sleep. 'Sleep' icon blinks and the reservation time is displayed.



3 Use button to set the reservation time. Reservation time can be set between 1 ~ 12 hours.

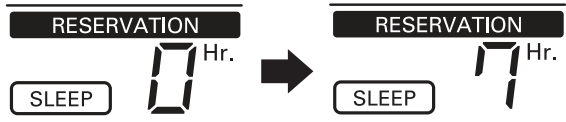
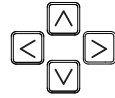

4 When Sleep reservation setting is finished, press button.



5 Pressing button will exit the settings mode.



- * If no button input for 60 seconds after the setting, it exits the settings mode automatically.
- * When exiting without pressing set button, the manipulated value is not reflected.
- When the reservation is set, 'Sleep' is displayed at the bottom of LCD screen.



- When the reservation is cancelled, 'Sleep' mark disappears.

6 When the sleep reservation setting is finished, it operates lightly for the set time.

11. LCD Wired Remote Control

Turn On Reservation

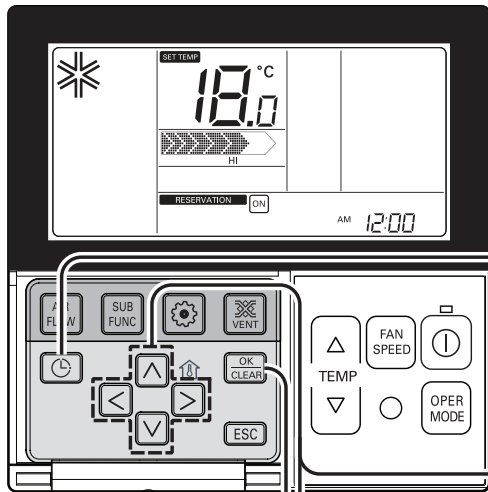

1 Press button.
Ex) Setting ON Reservation Time as 'AM 10:20'.

2 Repeat pressing button to enter the ON reservation setting mode.
(segment flashing)

3 Press button to adjust AM/ PM setting.
 AM 12:00

4 Press button to Hour setting mode. When the Hour icon flash, please setting time.
The setting range is within 1~12.
 AM 12:00
 AM 10:00

5 Press button to shift to Minute setting mode. When the Minute icon flash, please setting minute the setting range is within 00~59.
 AM 10:00
 AM 10:20

6 Press button to finish setting.
 AM 10:20

11. LCD Wired Remote Control

[Unit : mm]

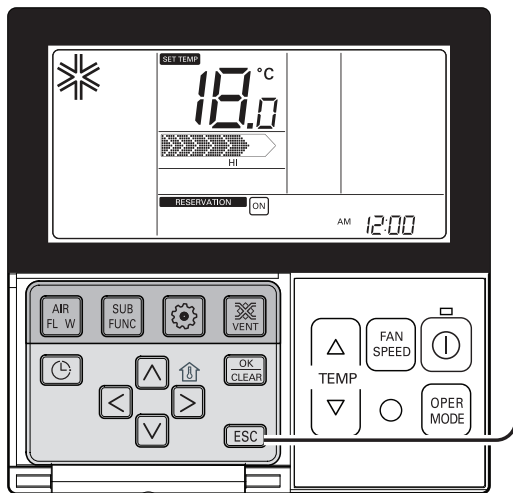

- 7** Press **ESC** button to exit.
- * After setup, it automatically gets out of setup mode if there is no button input for 25 seconds.
 - * When exiting without pressing set button, the manipulated value is not reflected.
 - If reservation is set, 'turned on' indication shows up at the lower part of LCD screen, and air-conditioner product runs at the time that is set.
 - If reservation is cancelled, 'turned on' indication disappears.

11. LCD Wired Remote Control

Turn Off Reservation

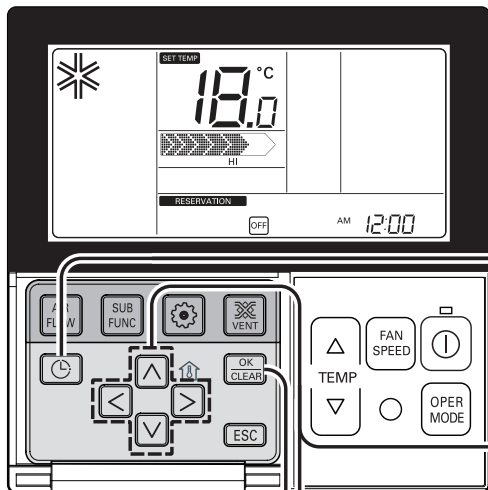

1 Press button.
Ex) Setting OFF Reservation Time as 'AM 10:20'.



2 Repeatedly pressing button to enter the OFF reservation setting mode.
(segment flashing)



3 Press button to adjust AM/ PM setting.

AM 12:00

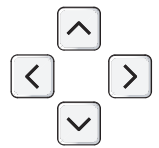

4 Press button to shift to Hour setting mode. When the Hour icon flash, please setting time.
The setting range is within 1~12.

AM 12:00

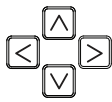

AM 10:00

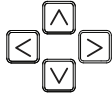

5 Press button to shift to Minute setting mode. When the Minute icon flash, please setting minute the setting range is within 00~59.

AM 10:00

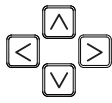

6 Press button to finish setting.

AM 10:20



11. LCD Wired Remote Control

[Unit : mm]

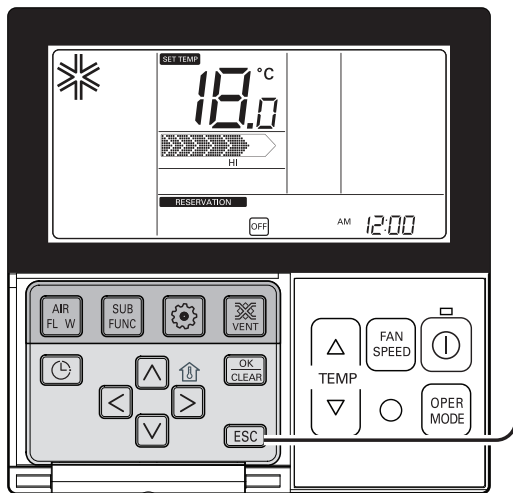











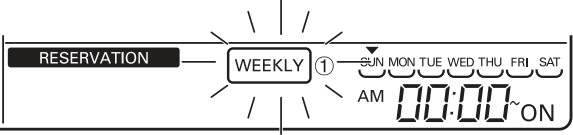

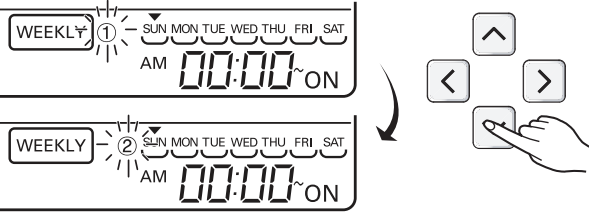

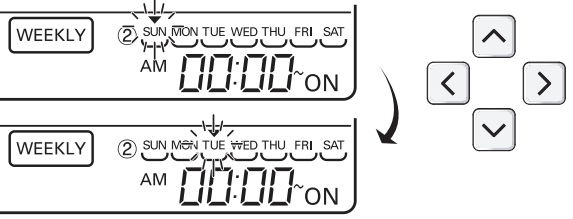
- 7** Press **ESC** button to exit.
- * After setup, it automatically gets out of setup mode if there is no button input for 25 seconds.
 - * When exiting without pressing set button, the manipulated value is not reflected.
 - If reservation is set, 'turned off' indication shows up at the lower part of LCD screen, and air-conditioner product runs at the time that is set.
 - If reservation is cancelled, 'turned off' indication disappears.

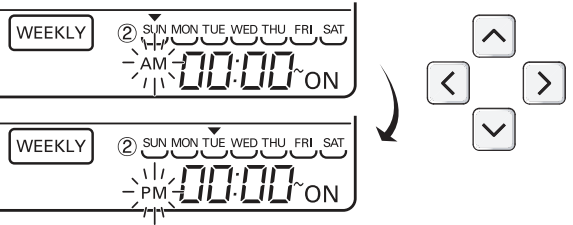
11. LCD Wired Remote Control

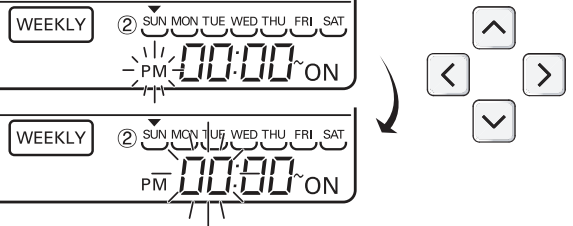
Weekly Reservation

You can set the daily reservation in weekly unit.

Weekly reservation keeps operating until before you cancel it once you setup

<p>1 Please move to reservation setup mode by pressing reservation button. * You can setup two weekly reservations for one day, and up to fourteen reservations for a week. For example, to setup (Tuesday morning 11:30 turned on ~ afternoon 12:30 turned off), you setup in order below.</p>	
<p>2 Please move to 'weekly' by repeatedly pressing reservation button. 'Weekly' blinks at this time.</p>	
<p>3 Please select weekly reservation ① or weekly reservation ② by using   button. * You can setup two reservations, weekly reservation 1 and weekly reservation 2, for a day.</p>	
<p>4 Please move to 'date' setup part by using   button. If 'date' indication blinks, please setup date. You can setup date from Monday to Sunday.</p>	
<p>5 Please move to 'AM/PM' setup part of turning on by using   button.</p>	
<p>6 Please move to 'hour' setup part of turning on by using   button. - It is the part to setup the time at which air-conditioner is turned on.</p>	
<p>7 Please change time by using   button. - You can setup hour 0~12.</p>	
<p>8 Please move to 'minute' setup part of turning on by using  button.</p>	
<p>9 If 'minute' indication blinks, please setup 'minute' by using   button</p>	

11. LCD Wired Remote Control

[Unit : mm]

10 Please move to 'AM/PM' setup part of turning off by using button.
 - AM/PM setup is identical with turning on time setup.

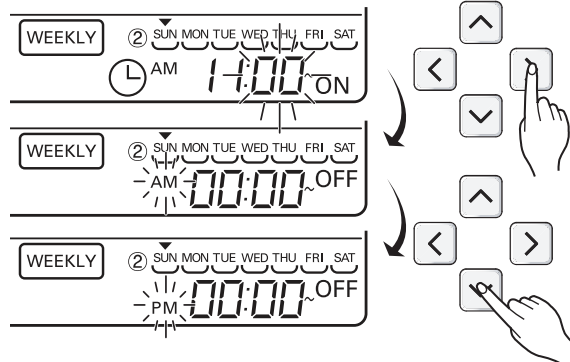

11 Please move to 'hour' setup part of turning off by using Right button.
 - It is the part to reserve the time at which air-conditioner is turned off.
 - If 'hour' indication blinks, please setup 'hour'.

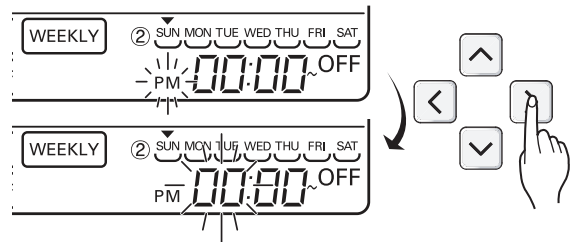

* Please setup 'hour' and 'minute' identically with the method to setup turning on time.

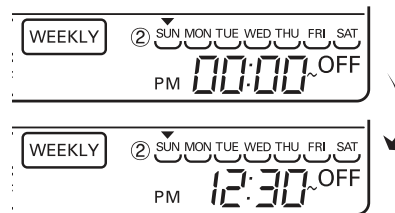

12 If finishing weekly reservation setup, please press setup/cancellation button. Weekly reservation setup for the day that you set is finished.

13 If you setup with the method identical with above by selecting the day that you'd like to setup, it operates weekly reservation.
 If you setup both turning on reservation time and turning off reservation time identically, it doesn't operate reservation drive.

Weekly reservation explanation

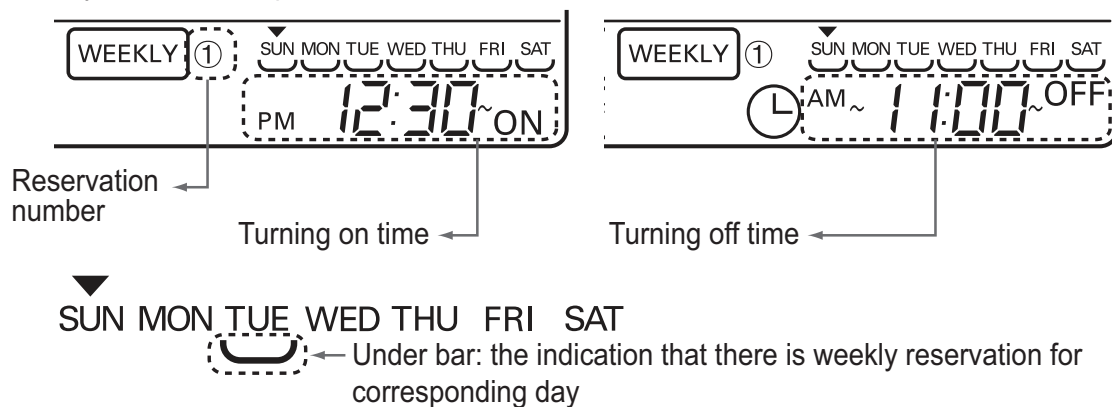

11. LCD Wired Remote Control

■ Holiday Reservation

It automatically stops at reserved day that you set.

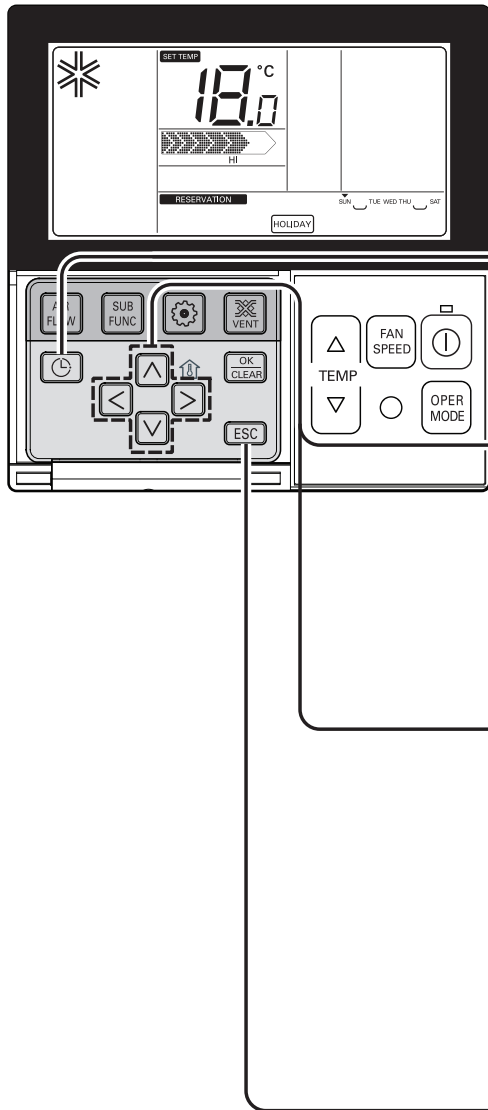

- 1** Please press button. It enters into reservation setup mode.

- 2** Please move to 'holiday' by repeatedly pressing button.

- 3** Please move to 'date' that you want to setup holiday by using button.

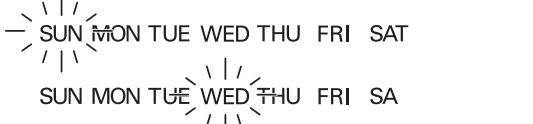
- 4** Please appoint or cancel holiday by using or button.
For example, when you setup Monday/Friday to holiday - 'Monday', 'Friday' letter disappears.

- 5** Please press button if finishing holiday setup.

 - * If it comes to appointed holiday, air-conditioner automatically stops. Once you setup holiday appointment, until before you cancel holiday setup, air-conditioner automatically stops within one hour even though you run air-conditioner.



Air Solution

LG Electronics Inc, 128, Yeoui-daero,
Yeongdeungpo-gu, Seoul, Korea
(07336)
<http://partner.lge.com>

Copyright © 2018-2024 LG Electronics Inc.
All Rights Reserved.
Printed in Korea January / 2024

The air conditioners manufactured by LG have received ISO9001 certificate for quality assurance and ISO14001 certificate for environmental management system.
The specifications, designs, and information in this brochure are subject to change without notice.