

LG

FCU

Fan Coil Unit

50/60Hz

5CFIW_02B(Replaces 5CFIW_02A)

TOTAL HVAC

SOLUTION

PROVIDER

ENGINEERING PRODUCT DATA BOOK

FCU

General Information

Product Data

Ceiling Mounted Cassette (4-Way)

Ceiling Mounted Cassette (Dual Vane 4-Way)

Ceiling Concealed Duct (Middle Static)

Ceiling Concealed Duct (Low Static)

Installation

FCU

General Information

- 1. Model Lineup**
- 2. Nomenclature**
- 3. Indoor Unit Capacity Index**

1. Model line up

■ Ceiling Mounted Cassette

◆ 4 Way (WF4A***CG0A)

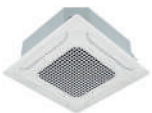
Chassis		Capacity [kW] (***)								
		1.8 (018)	2.7 (027)	3.2 (032)	4.1 (041)	6.0 (060)	7.2 (072)	9.0 (090)	10.5 (105)	13.0 (130)
	TR	○	○	○						
	TQ				○					

◆ Dual Vane 4 Way (WF4A***CG0B)

Chassis		Capacity [kW] (***)								
		1.8 (018)	2.7 (027)	3.2 (032)	4.1 (041)	6.0 (060)	7.2 (072)	9.0 (090)	10.5 (105)	13.0 (130)
	TP-B					○	○			
	TM-A							○	○	○

Note

- Indoor Units bigger than 7.2kW can not be combined Hybrid unit system.

■ Ceiling Concealed Duct

◆ Middle static (WFCB***RG0A / WFCB***LG0A)

Chassis		Capacity [kW] (***)						
		5.6 (056)	6.6 (066)	9.0 (090)	10.0 (100)	10.9 (109)	12.7 (127)	14.0 (140)
	M1	○	○					
	M2			○	○	○		
	M3						○	○

◆ Low static (WFCA***RG0A)

Chassis		Capacity [kW] (***)						
		1.2 (012)	1.8 (018)	2.5 (025)	3.2 (032)	3.9 (039)	5.5 (055)	6.6 (066)
	L1	○	○					
	L2			○	○			
	L3					○	○	○

Note

- Indoor Units bigger than 7.2kW can not be combined Hybrid unit system.

2. Nomenclature

Model Name	WF	4	A	018	C	G	0	A
No.	1	2	3	4	5	6	7	8

No.	Signification
1	Type of air conditioner WF : Fan Coil Unit
2	Model Type 4 : 4 Way Cassette C : Ceiling Concealed Duct
3	Coil A : 2 pipe / 2 column B : 2 pipe / 3 column
4	Total Cooling Capacity in kW EX) 1.8 kW Class → '018' 13 kW Class → '130'
5	Piping Direction C : Common R : Right L : Left
6	Electrical Ratings G : 1Ø, 220-240V, 50/60Hz
7	Function 0 : Basic
8	Serial Number

3. Indoor Unit Capacity Index

■ Indoor unit capacity index

Unit Capacity (kW)	1.2	1.8	2.5	2.7	3.2	3.9	4.1	5.5	5.6	6.0	6.6	7.2	9.0	10.0	10.5	10.6	12.7	13.0	14.0
Capacity Index	1.2	1.8	2.5	2.7	3.2	3.9	4.1	5.5	5.6	6.0	6.6	7.2	9.0	10.0	10.5	10.6	12.7	13.0	14.0

- Capacity Index is same as the capacity with 'kW' unit.
- In matters of combination with Hybrid unit system, refer the PDB of that Hybrid unit system.
- Indoor Units bigger than 7.2kW can not be combined Hybrid unit system.

FCU

Product Data

Ceiling Mounted Cassette(4-Way)

Ceiling Mounted Cassette(Dual Vane 4-Way)

Ceiling Concealed Duct(Middle Static)

Ceiling Concealed Duct(Low Static)

FCU

Ceiling Mounted Cassette (4-Way)

- 1. List of functions**
- 2. Specifications**
- 3. Dimensions**
- 4. Piping Diagrams**
- 5. Wiring Diagrams**
- 6. Capacity Tables**
- 7. Air Velocity and Temperature Distribution**
- 8. Electric Characteristics**
- 9. Sound Levels**

1. List of Functions

■ List of Function

Category	Function	WF4A018CG0A, WF4A027CG0A, WF4A032CG0A , WF4A041CG0A
Air flow	Air supply outlet	4
	Airflow direction control(left & right)	-
	Airflow direction control(up & down)	Auto
	Auto swing(left & right)	-
	Auto swing(up & down)	O
	Airflow steps(fan/cool/heat)	4 / 4 / 4
	Chaos swing	X
	Chaos wind(auto wind)	O
	Jet cool(Power wind)	O
Swirl wind*	O	
Air purifying	Deodorizing filter	X
	Plasma air purifier	X
	Prefilter(washable / anti-fungus)	O
Installation	Drain pump	O
	E.S.P. control*	X
	Electric heater(operation)	X
	High ceiling operation*	O
Reliability	Hot start	O
	Self diagnosis	O
	Soft dry operation	X
Convenience	Auto changeover	X
	Auto cleaning	X
	Auto operation(artificial intelligence)	X
	Auto restart operation	O
	Child lock*	O
	Forced operation	O
	Group control*	O
	Sleep mode	O
	Timer(on/off)	O
	Timer(weekly)*	O
	Two thermistor control*	O
	External On/Off	O
Advanced Fan Speed Auto	O	
Others	Cold And Hot Water Valve Control (ON/OFF, AC 220 V)	O
	Cold And Hot Water Valve Control (Proportional Control, DC 0~10 V)	X
	Freeze Protection Control	O

Note

- O : Applied, X : Not applied
Accessory : Ordered and purchased separately the accessory package referring to the model name provided and install at field.
Accessory line-ups varies by region, so check your local catalogue or local sales material.
- Some functions can be limited by remote controller.
- In case of ducted type indoor units using the wireless remote controller, it needs to connect to the wired remote controller for received the signal of that.
- * : These functions need to connect the wired remote controller.

1. List of Functions

◆ Accessory Compatibility List

Category		Product	Remark	Compatibility
				WF4A---CG0A
Wireless Remote Controller		PQWRH(C)Q0FDB	-	O
Wired Remote Controller	Simple	PQRCVCL0Q(W)	Simple	O
		PQRCHCA0Q(W)	for Hotel	O
	Standard	PREMTB001	Standard (White)	O
		PREMTBB01	Standard (Black)	O
		PREMTB100*	New Standard (White)	O
		PREMTBB10*	New Standard (Black)	O
Premium	PREMTA000(A/B)	Premium	O	
Dry contact	Simple Contact	PDRYCB000	Simple Dry Contact	O
	Communication type	PDRYCB400	Points Dry Contact (For Setback)	O
		PDRYCB300	Dry Contact For 3rd Party Thermostat	O
		PDRYCB500	Dry Contact For Modbus	O
Gateway	IDU PI485	PHNFP14A0	Connected with the Indoor Units	-
		PSNFP14A0	Connected with the Indoor Units	-
ETC	Remote temperature sensor	PQRSTA0	-	O
	CO2 Sensor	PES-C0RV0	-	-
	Group control wire	PZCWRCG3	0.25m	O
	2-Remo Control Wire	PZCWRC2	0.25m	O
	Extension Wire	PZCWRC1	10m	O
	Wi-Fi Controller*	PWFMD200	-	O
	Independent Power Module	PRIP0	-	X
	Human Detecting Controller	PHD-TM0	-	O (TP,TN,TM only)

Note

1. O: Possible, X: Impossible, - : Not applicable, Embedded : Included with product.
2. * : Some advanced functions controlled by individual controller cannot be operated.
3. ** : It could not be operated some functions.
4. If you need more detail, please refer to the **BECON** PDB or the manual of product. (<http://partner.lge.com> > Select Your Region : Home> Doc.Library> Product > Control(BECON))

1. List of Functions

■ Panel(Accessory)

Model Name			PT-QCHW0	PT-QAGW0
Description		-	Standard Panel	Standard Panel
Panel Exterior	Color	-	Morning Fog	White
	RAL (Classic)	-	RAL 9001	RAL 9003
	Type		Grille	Grid
Dual Vane		-	X	X
Dimensions	Net (W x H x D)	mm	620 × 34 × 620	620 × 35 × 620
	Shipping (W x H x D)	mm	688 × 127 × 670	688 × 127 × 673
Weight	Net	kg	3.00	2.85
	Shipping	kg	4.00	3.90
Function	PM1.0 Sensor	-	X	X
Accessory	Air Purification Kit	-	X	X
	Floor Detection Sensor*	-	X	X
	Human Detection Sensor*	-	X	X

Note

1. Accessory : Ordered and purchased separately the accessory package referring to the model name provided and install at field.
2. * : This functions need to connect to the RS3 wired remote controller(Standard III).

Model Name			PT-MCHW0
Description		-	Standard Panel
Panel Exterior	Color	-	Morning Fog
	RAL (Classic)	-	RAL 9001
	Type		Grille
Dual Vane		-	X
Dimensions	Net (W x H x D)	mm	950 x 35 x 950
	Shipping (W x H x D)	mm	1,004 × 110 × 1,019
Weight	Net	kg	6.30
	Shipping	kg	8.50
Function	PM1.0 Sensor	-	X
Accessory	Air Purification Kit	-	X
	Floor Detection Sensor*	-	X
	Human Detection Sensor*	-	X

Note

1. Accessory : Ordered and purchased separately the accessory package referring to the model name provided and install at field.
2. * : This functions need to connect to the RS3 wired remote controller(Standard III).

2. Specifications

Type		4 Way Ceiling Mounted Cassette		
		Model	Unit	WF4A018CG0A
Power Supply	Rated Power Supply	V, Φ, Hz	220-230-240, 1, 50	220-230-240, 1, 50
	Limit Range of Voltage	V	198 ~ 264	198 ~ 264
Running Current by Voltage		A	0.39 - 0.37 - 0.35	0.40 - 0.38 - 0.36
Capacity	Cooling	Condition A	1.8(1,548)	2.7(2,322)
		Condition B	1.2(1,032)	1.8(1,548)
		Condition C	1.5(1,290)	2.3(1,978)
		Condition D	0.7(602)	1.2(1,032)
	Heating	Condition A	2.2(1,892)	3.1(2,666)
		Condition B	1.9(1,634)	2.7(2,322)
Water Flow Rate	Cooling	Condition A	5.7	8.2
		Condition B	4.6	6.6
		Condition C	5.7	8.2
		Condition D	3.4	4.9
	Heating	Condition A	6.1	8.6
		Condition B	5.7	8.2
Head Loss	Cooling	Condition A	21.5	32.0
		Condition B	13.7	20.3
		Condition C	21.5	32.0
		Condition D	8.1	12.0
	Heating	Condition A	30.3	40.7
		Condition B	26.2	36.5
Power Input	H/M/L	W	12 / - / -	15 / - / -
Running Current	H/M/L	A	0.37 / - / -	0.38 / - / -
Fan	Type	-	Turbo Fan	Turbo Fan
	Air Flow Rate(H/M/L)	m ³ /min	6.5 / 5.5 / 5.0	7.0 / 6.5 / 6.0
Fan Motor	Type	-	BLDC	BLDC
	Drive	-	Direct	Direct
	Output	W × No.	30 × 1	30 × 1
Dimensions	Net (W × H × D)	mm	570 × 214 × 570	570 × 214 × 570
	Shipping (W × H × D)	mm	652 × 270 × 636	652 × 270 × 636
Weight	Net	kg	12.9	12.9
	Shipping	kg	15.7	15.7
Exterior	Color	-	-	-
	RAL (Classic)	-	-	-
Air Filter	Type	-	Long life	Long life
Temperature Control	-	-	Microprocessor, Thermostat for cooling and heating	
Sound Absorbing / Thermal Insulation Material	-	-	Foamed polystyrene	Foamed polystyrene
Protection Device	-	-	Fuse	Fuse
Water Connecting Pipes	Inlet	-	BSPF G 3/4"(male)	BSPF G 3/4"(male)
	Outlet	-	BSPF G 3/4"(male)	BSPF G 3/4"(male)
Drain Pipe (Natural Drainage)	O.D / I.D	mm	-	-
Drain Pipe (using Drain Pump)	O.D / I.D	mm	Ø 32.0 / 25.0	Ø 32.0 / 25.0
Sound Pressure Level	H/M/L	dB(A)	35.0 / 34.0 / 33.0	38.0 / 37.0 / 35.0
Sound Power Level	H/M/L	dB(A)	40.0 / 39.0 / 38.0	44.0 / 42.0 / 40.0
Connecting Cable	Communication Cable (VCTF-SB)	mm ² ×cores	1.0 ~ 1.5 × 2C	1.0 ~ 1.5 × 2C

Note

- Due to our policy of innovation some specifications may be changed without notification.
- Wiring cable size must comply with the applicable local and national codes. And "Electric characteristics" chapter should be considered for electrical work and design. Especially the power cable and circuit breaker should be selected in accordance with that.
- Sound Level Values are measured at Noise Measuring chamber accordance with standard. Therefore, these values depend on the ambient conditions and values are normally higher in actual operation.
- Performances are based on the following conditions :
 - Cooling
 - Condition A : Inlet/Outlet Water Temp. 7°C / 12°C, Indoor Air Temp. 27°CDB / 19°CWB
 - Condition B : Inlet/Outlet Water Temp. 10°C / 15°C, Indoor Air Temp. 27°CDB / 19°CWB
 - Condition C : Inlet/Outlet Water Temp. 7°C / 12°C, Indoor Air Temp. 25°CDB / 17.9°CWB
 - Condition D : Inlet/Outlet Water Temp. 14°C / 18°C, Indoor Air Temp. 26°CDB / 18°CWB
 - Heating
 - Condition A : Inlet/Outlet Water Temp. 45°C / 40°C, Indoor Air Temp. 20°CDB / 15°CWB
 - Condition B : Inlet Water Temp. 50°C, Indoor Air Temp. 20°CDB / 15°CWB
- Capacity, power consumption, etc. may vary depending on the product installation conditions (temperature, conditions of use).
- Main power line should be shorter than 50m. When installing a power line longer than 50m, contact LG Electronics.

2. Specifications

Type		4 Way Ceiling Mounted Cassette		
Model		Unit	WF4A032CG0A	WF4A041CG0A
Power Supply	Rated Power Supply	V, Φ, Hz	220-230-240, 1, 50	220-230-240, 1, 50
	Limit Range of Voltage	V	198 ~ 264	198 ~ 264
Running Current by Voltage		A	0.42 - 0.40 - 0.38	0.44 - 0.42 - 0.40
Capacity	Cooling	Condition A	3.2(2,752)	4.1(3,525)
		Condition B	2.2(1,892)	2.8(2,408)
		Condition C	2.8(2,408)	3.6(3,095)
		Condition D	1.4(1,204)	1.8(1,548)
	Heating	Condition A	3.3(2,837)	4.5(3,869)
		Condition B	3.9(3,353)	5.4(4,643)
Water Flow Rate	Cooling	Condition A	10.0	13.5
		Condition B	8.0	10.8
		Condition C	10.0	13.5
		Condition D	6.0	8.1
	Heating	Condition A	10.0	13.5
		Condition B	10.0	13.5
Head Loss	Cooling	Condition A	47.7	43.7
		Condition B	30.3	27.8
		Condition C	47.7	43.7
		Condition D	17.9	16.4
	Heating	Condition A	53.8	56.5
		Condition B	53.8	56.5
Power Input	H/M/L	W	20 / - / -	43 / - / -
Running Current	H/M/L	A	0.40 / - / -	0.42 / - / -
Fan	Type	-	Turbo Fan	Turbo Fan
	Air Flow Rate(H/M/L)	m ³ /min	8.5 / 8.0 / 7.0	12.0 / 10.0 / 8.0
Fan Motor	Type	-	BLDC	BLDC
	Drive	-	Direct	Direct
	Output	W x No.	30 x 1	43 x 1
Dimensions	Net (W x H x D)	mm	570 x 214 x 570	570 x 256 x 570
	Shipping (W x H x D)	mm	652 x 270 x 636	667 x 327 x 646
Weight	Net	kg	12.9	14.0
	Shipping	kg	15.7	16.3
Exterior	Color	-	-	-
	RAL (Classic)	-	-	-
Air Filter	Type	-	Long life	Long life
Temperature Control		-	Microprocessor, Thermostat for cooling and heating	
Sound Absorbing / Thermal Insulation Material		-	Foamed polystyrene	Foamed polystyrene
Protection Device		-	Fuse	Fuse
Water Connecting Pipes	Inlet	-	BSPF G 3/4"(male)	BSPF G 3/4"(male)
	Outlet	-	BSPF G 3/4"(male)	BSPF G 3/4"(male)
Drain Pipe (Natural Drainage)	O.D / I.D	mm	-	-
Drain Pipe (using Drain Pump)	O.D / I.D	mm	Ø 32.0 / 25.0	Ø 32.0 / 25.0
Sound Pressure Level	H/M/L	dB(A)	43.0 / 40.0 / 38.0	48.0 / 43.0 / 38.0
Sound Power Level	H/M/L	dB(A)	50.0 / 46.0 / 44.0	56.0 / 50.0 / 45.0
Connecting Cable	Communication Cable (VCTF-SB)	mm ² ×cores	1.0 ~ 1.5 × 2C	1.0 ~ 1.5 × 2C

Note

- Due to our policy of innovation some specifications may be changed without notification.
- Wiring cable size must comply with the applicable local and national codes. And "Electric characteristics" chapter should be considered for electrical work and design. Especially the power cable and circuit breaker should be selected in accordance with that.
- Sound Level Values are measured at Noise Measuring chamber accordance with standard. Therefore, these values depend on the ambient conditions and values are normally higher in actual operation.
- Performances are based on the following conditions :
 - Cooling
 - Condition A : Inlet/Outlet Water Temp. 7°C / 12°C, Indoor Air Temp. 27°CDB / 19°CWB
 - Condition B : Inlet/Outlet Water Temp. 10°C / 15°C, Indoor Air Temp. 27°CDB / 19°CWB
 - Condition C : Inlet/Outlet Water Temp. 7°C / 12°C, Indoor Air Temp. 25°CDB / 17.9°CWB
 - Condition D : Inlet/Outlet Water Temp. 14°C / 18°C, Indoor Air Temp. 26°CDB / 18°CWB
 - Heating
 - Condition A : Inlet/Outlet Water Temp. 45°C / 40°C, Indoor Air Temp. 20°CDB / 15°CWB
 - Condition B : Inlet Water Temp. 50°C, Indoor Air Temp. 20°CDB / 15°CWB
- Capacity, power consumption, etc. may vary depending on the product installation conditions (temperature, conditions of use).
- Main power line should be shorter than 50m. When installing a power line longer than 50m, contact LG Electronics.

3. Dimensions

3.1 Dimensional Drawings

■ WF4A018CG0A, WF4A027CG0A, WF4A032CG0A

◆ TR Chassis (PT-QAGW0)

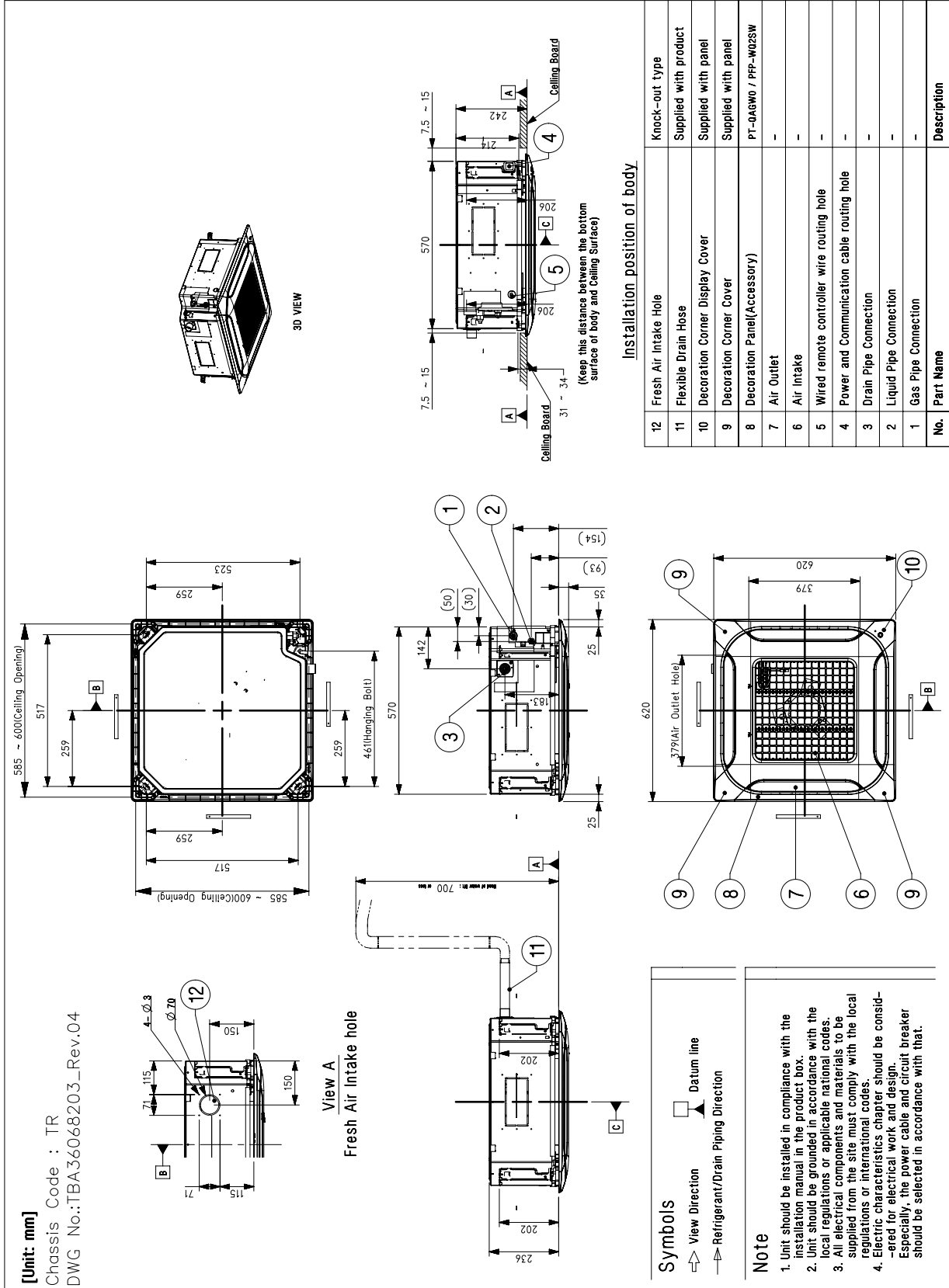

3. Dimensions

◆ TR Chassis (PT-QCHW0)

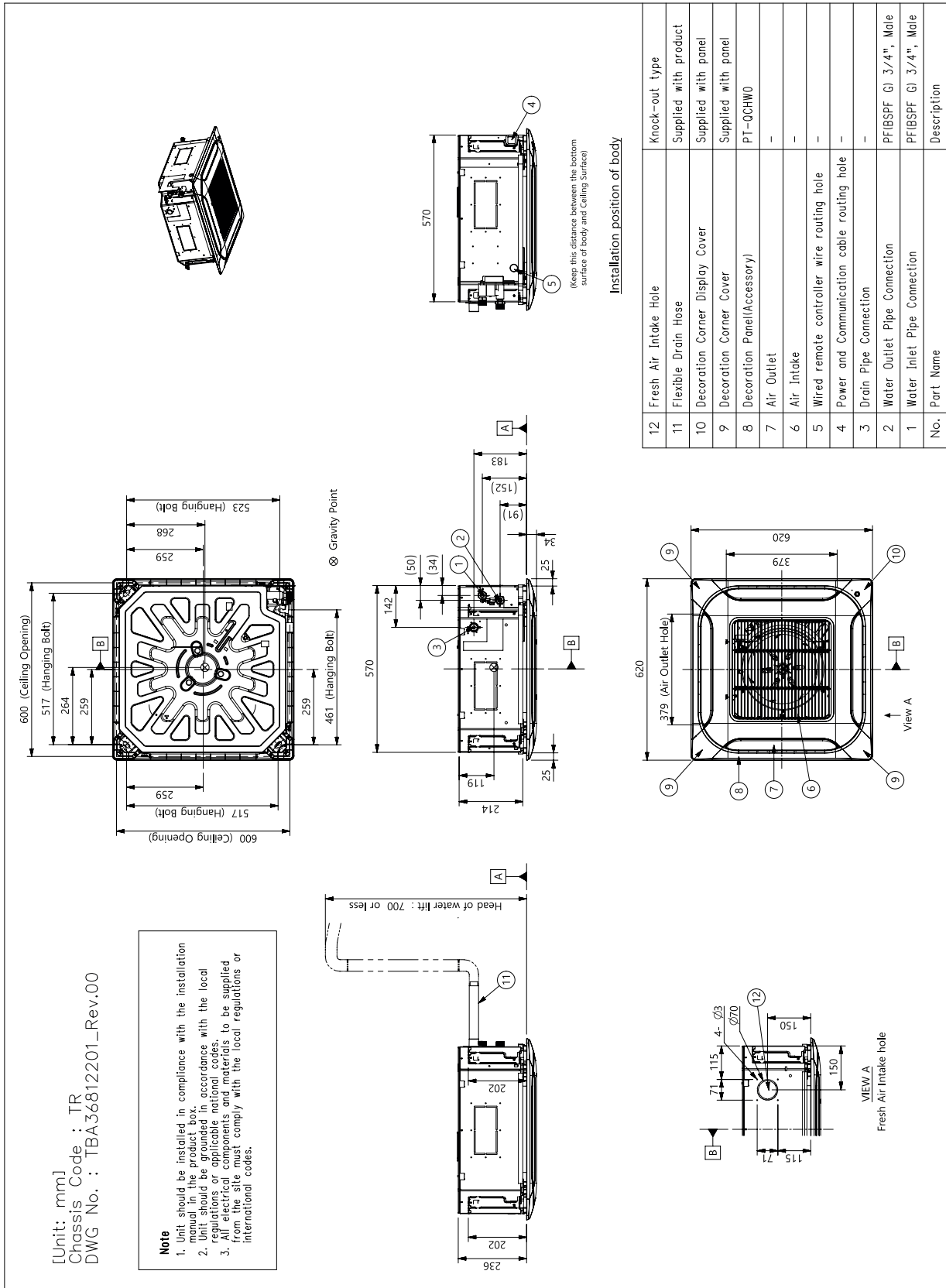

3. Dimensions

■ WF4A041CG0A

◆ TQ Chassis (PT-QAGW0)

[Unit: mm]
Chassis Code : TQ
DWG No. : TBA36812901_Rev.01

3D VIEW

Gravity Point

View A
Fresh Air Intake hole

(Keep this distance between the bottom surface of body and Ceiling Surface)

Installation position of body

No.	Part Name	Description
11	Fresh Air Intake Hole	Knock-out type
10	Fixble Drain Hose	-
9	Decoration Corner Cover	Supplied with panel
8	Decoration Panel(Accessory)	PT-QAGW0, PFP-WQ2SW
7	Air Outlet	-
6	Air Inlet	-
5	Wired remote controller wire routing hole	-
4	Power and communication cable routing hole	-
3	Drain Pipe Connection	-
2	Water Outlet Pipe Connection	PF(BSPF G) 3/4", Male
1	Water Inlet Pipe Connection	PF(BSPF G) 3/4", Male
	No.	Part Name
		Description

Note

- Unit should be installed in compliance with the installation instructions in the product box.
- Installation should be in accordance with the local regulations or applicable national codes.
- All electrical components and materials to be supplied from the site must comply with the local regulations or international codes.

3. Dimensions

◆ TQ Chassis (PT-QCHW0)

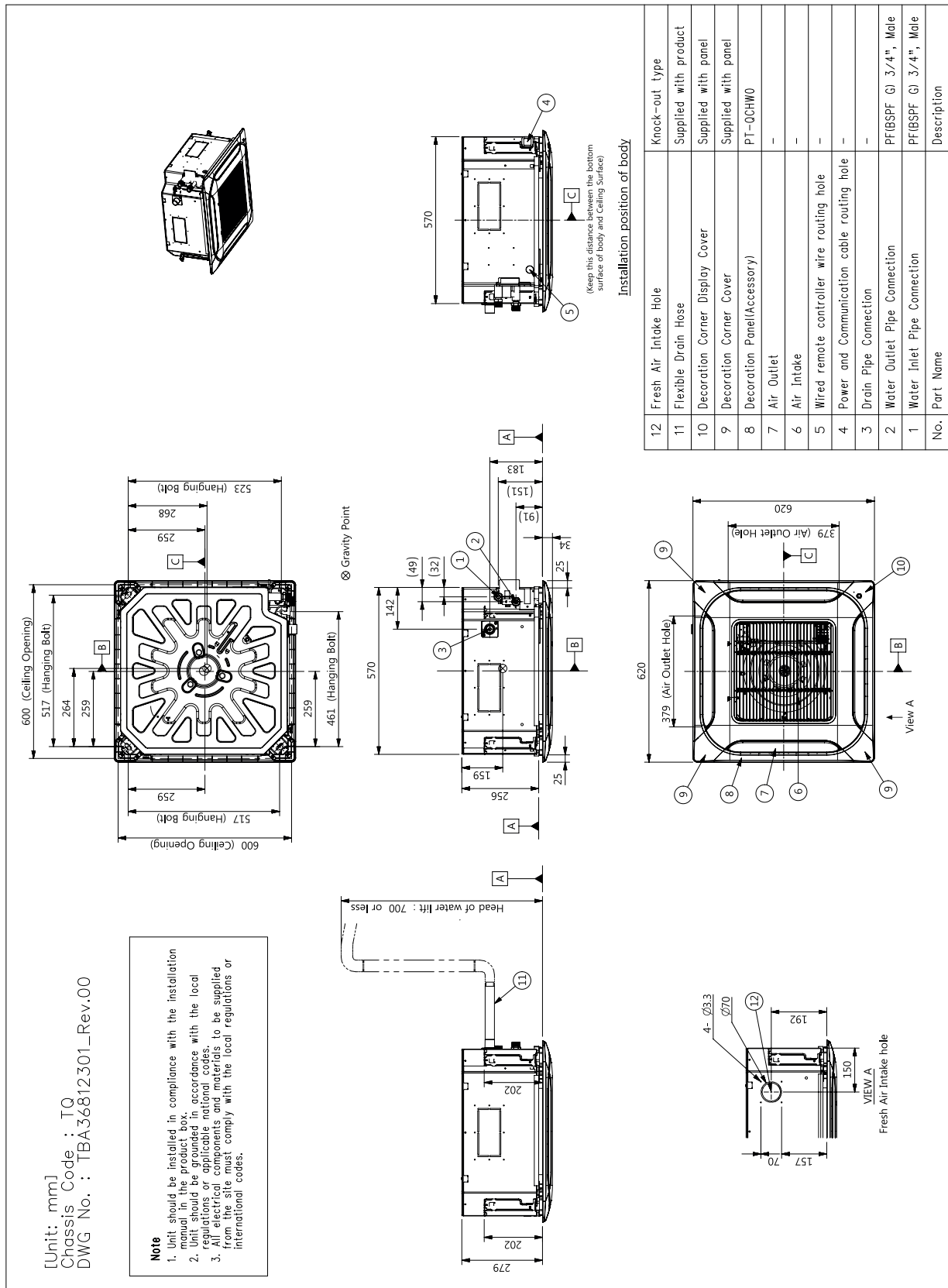

3. Dimensions

3.2 Installation Space

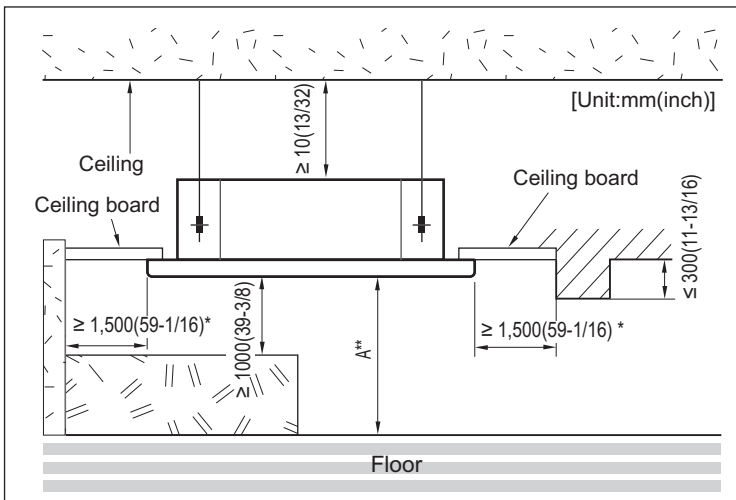

Notes

1. *: Minimum Installation Space to Air flow direction
A separation distance of at least 1,500 mm is required throughout the airflow direction.

2. **: A, Installation Height from the floor

Capacity Class	Installation Height (A)		
	Min.	Standard ***	Max.
< 10 kW	2.0 m (6.56 ft)	2.7 m (8.86 ft)	3.6 m (11.81 ft)
≥ 10 kW	2.5 m (8.20 ft)	3.2 m (10.50 ft)	4.2 m (13.78 ft)

*** : Standard Height (Recommended)

If it exceeds the standard height, set the 'High Ceiling Mode'.
For details about function setting, refer to the installation manual.

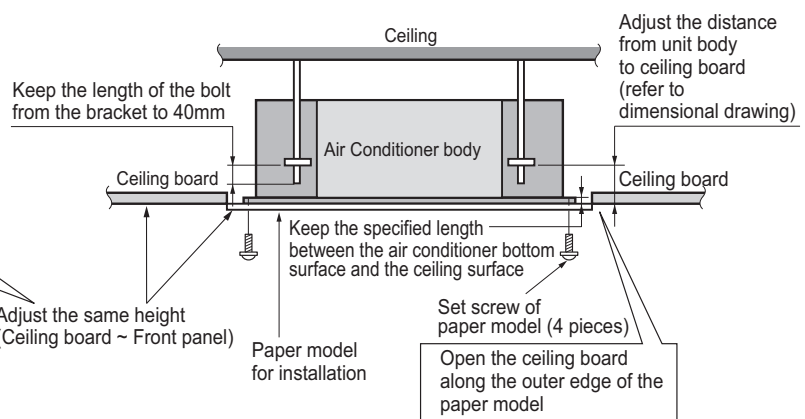
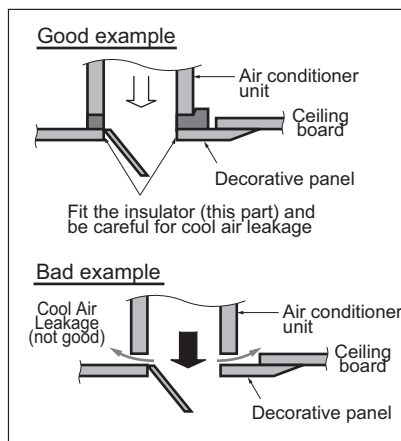

Note

- Places where products are installed should not be any obstacles to the air circulation or installation. Ensure the spaces from the wall, ceiling, or other obstacles.
- According to type of indoor unit, external appearance or installed structure could be different.
- According to product type, model line up, sales region..etc, applicability of each chassis could be different.
- Install certainly the decoration panel. Cool air leakage causes sweating or falling of water-drops.

4. Piping Diagrams

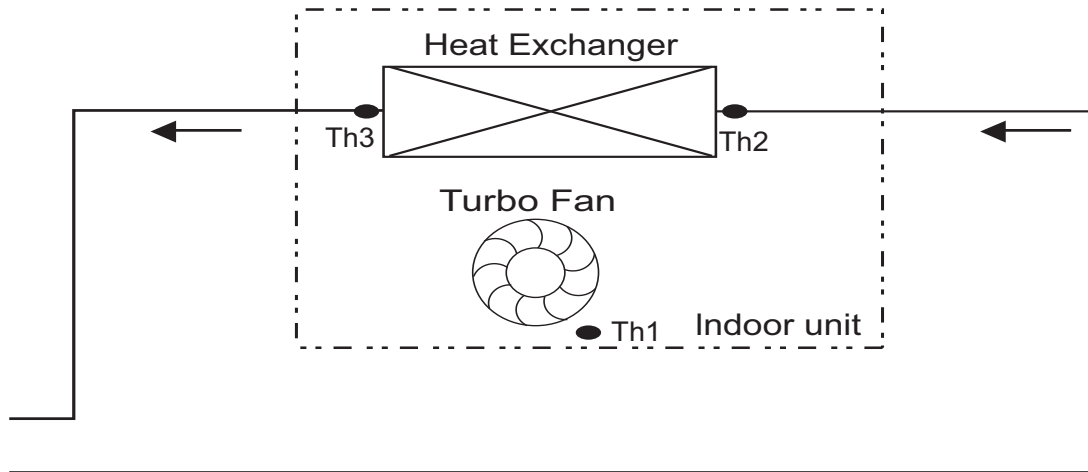

LOC.	Description
Th1	Room thermistor
Th2	Pipe in thermistor
Th3	Pipe out thermistor

5. Wiring diagrams

TR / TQ Chassis

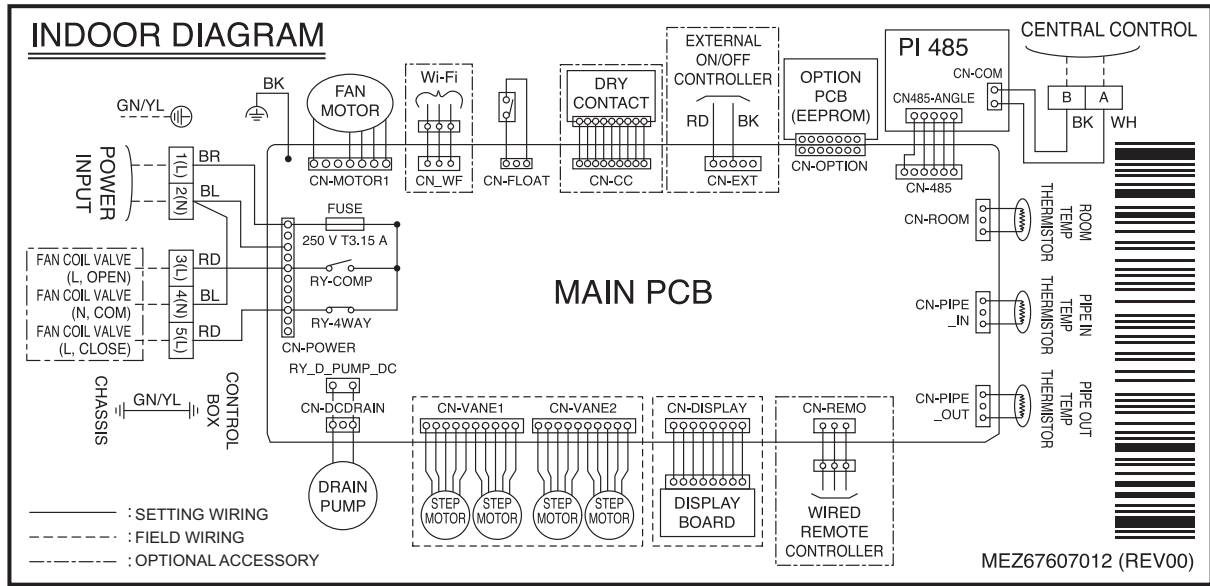

Dip SW Setting Table

No.	Function	Description	Setting		Default (At the time of factory ship-out)	FCU
			OFF	ON		
SW1	Communication mode	Communication / Non communication model selection	Communication	Non communication	ON	Use
SW2	Cooling / heating mode	Cooling / heating mode selection	Cooling/heating	Cooling exclusive	OFF	Use
SW3	Group control	Master / slave selection	Master	Slave	OFF	Use
SW4	Dry contact mode	- Variable : Manual or automatic selection of wired wireless remote control - Automatic	Variable	Automatic	OFF	Use
SW5	Fan continous operation	For Duct type	Fan continous operation removal	Fan continous operation	OFF	N/A
	EXTRA	Cassette type	-	-	OFF	
	Installation type	For Ceiling Suspended type	Ceiling	Floor	OFF	
SW6	Heater linkage	For Round Cassette	Exposed	Half Concealed	OFF	N/A
		-	-	-	OFF	
SW7	Ventilator linkage	Selection of Ventilator linkage	Linkage Removal	Working	OFF	N/A
	Vane selection (Console)	For Console type (Top/Bottom vane)	Top + Bottom Vane	Top Vane Only		
	Region selection	Selection tropical region	General model	Tropical model		
SW8	Communication method	LGAP/Modbus selection	Modbus	LGAP	OFF	Use

Note

- For product type, available Dip Switch No. could be different.
- Dip switch marked 'N/A' should be OFF. Those will be used for other product.

6. Capacity Tables

Inlet Water Temp. (°C)	Water Temp Difference (°C)	Air Temp (°C DB)	Air Temp(17°C WB)				Air Temp(19°C WB)				Air Temp(21°C WB)				Air Temp(23°C WB)			
			TC (kW)	SHC (kW)	Water Flow Rate (LPM)	Pressure Drop (kPa)	TC (kW)	SHC (kW)	Water Flow Rate (LPM)	Pressure Drop (kPa)	TC (kW)	SHC (kW)	Water Flow Rate (LPM)	Pressure Drop (kPa)	TC (kW)	SHC (kW)	Water Flow Rate (LPM)	Pressure Drop (kPa)
7	4	24	1.43	1.14	5.1	21.2	1.84	1.09	6.6	32.6	2.29	1.05	8.2	47.5	2.78	1.00	10.0	66.7
		25	1.43	1.22	5.1	21.1	1.83	1.18	6.6	32.5	2.28	1.13	8.2	47.4	2.78	1.08	10.0	66.6
		26	1.42	1.31	5.1	21.1	1.83	1.26	6.6	32.4	2.28	1.21	8.2	47.3	2.78	1.17	10.0	66.5
		27	1.42	1.39	5.1	21.0	1.83	1.34	6.6	32.3	2.28	1.30	8.2	47.2	2.77	1.25	10.0	66.3
		28	1.42	1.42	5.1	21.0	1.83	1.43	6.6	32.3	2.27	1.38	8.2	47.1	2.77	1.33	9.9	66.2
		29	1.42	1.42	5.1	20.9	1.82	1.51	6.5	32.2	2.27	1.46	8.2	47.0	2.77	1.42	9.9	66.1
	5	30	1.41	1.41	5.1	20.8	1.82	1.59	6.5	32.1	2.27	1.55	8.1	46.9	2.76	1.50	9.9	65.9
		24	1.40	1.13	4.0	14.0	1.81	1.08	5.2	21.7	2.26	1.03	6.5	31.7	2.75	0.99	7.9	44.6
		25	1.40	1.21	4.0	14.0	1.81	1.16	5.2	21.6	2.25	1.12	6.5	31.6	2.75	1.07	7.9	44.5
		26	1.40	1.29	4.0	14.0	1.80	1.25	5.2	21.6	2.25	1.20	6.5	31.5	2.75	1.16	7.9	44.4
		27	1.39	1.38	4.0	13.9	1.80	1.33	5.2	21.5	2.25	1.29	6.5	31.4	2.74	1.24	7.9	44.3
		28	1.39	1.39	4.0	13.9	1.80	1.42	5.2	21.4	2.25	1.37	6.4	31.4	2.74	1.32	7.9	44.2
	6	29	1.39	1.39	4.0	13.8	1.79	1.50	5.2	21.4	2.24	1.45	6.4	31.3	2.74	1.41	7.9	44.1
		30	1.39	1.39	4.0	13.8	1.79	1.58	5.1	21.3	2.24	1.54	6.4	31.2	2.73	1.49	7.9	44.0
		24	1.37	1.11	3.3	10.0	1.78	1.07	4.3	15.5	2.23	1.02	5.3	22.7	2.72	0.98	6.5	32.0
		25	1.37	1.20	3.3	9.9	1.78	1.15	4.3	15.4	2.23	1.11	5.3	22.6	2.72	1.06	6.5	31.9
		26	1.37	1.28	3.3	9.9	1.77	1.24	4.2	15.4	2.22	1.19	5.3	22.6	2.72	1.14	6.5	31.8
		27	1.37	1.37	3.3	9.9	1.77	1.32	4.2	15.3	2.22	1.27	5.3	22.5	2.71	1.23	6.5	31.8
	7	28	1.36	1.36	3.3	9.8	1.77	1.40	4.2	15.3	2.22	1.36	5.3	22.5	2.71	1.31	6.5	31.7
		29	1.36	1.36	3.3	9.8	1.77	1.49	4.2	15.3	2.21	1.44	5.3	22.4	2.71	1.39	6.5	31.6
		30	1.36	1.36	3.2	9.8	1.76	1.57	4.2	15.2	2.21	1.52	5.3	22.4	2.70	1.48	6.5	31.6
		24	1.34	1.10	2.8	7.3	1.75	1.06	3.6	11.6	2.20	1.01	4.5	17.1	2.69	0.96	5.5	24.1
		25	1.34	1.19	2.8	7.2	1.75	1.14	3.6	11.6	2.20	1.09	4.5	17.0	2.69	1.05	5.5	24.1
		26	1.34	1.27	2.7	7.2	1.75	1.22	3.6	11.5	2.19	1.18	4.5	17.0	2.69	1.13	5.5	24.0
	8	27	1.34	1.34	2.7	7.2	1.74	1.31	3.6	11.5	2.19	1.26	4.5	16.9	2.68	1.22	5.5	24.0
		28	1.34	1.34	2.7	7.2	1.74	1.39	3.6	11.5	2.19	1.35	4.5	16.9	2.68	1.30	5.5	23.9
		29	1.33	1.33	2.7	7.1	1.74	1.48	3.6	11.4	2.18	1.43	4.5	16.9	2.68	1.38	5.5	23.9
		30	1.33	1.33	2.7	7.1	1.73	1.56	3.6	11.4	2.18	1.51	4.5	16.8	2.67	1.47	5.5	23.8
		24	1.32	1.09	2.4	4.7	1.72	1.04	3.1	9.0	2.17	1.00	3.9	13.3	2.66	0.95	4.8	18.8
		25	1.31	1.17	2.4	4.7	1.72	1.13	3.1	9.0	2.17	1.08	3.9	13.3	2.66	1.04	4.8	18.8
9	26	1.31	1.26	2.4	4.7	1.72	1.21	3.1	8.9	2.16	1.17	3.9	13.2	2.66	1.12	4.8	18.8	
	27	1.31	1.31	2.3	4.6	1.71	1.30	3.1	8.9	2.16	1.25	3.9	13.2	2.65	1.20	4.8	18.7	
	28	1.31	1.31	2.3	4.6	1.71	1.38	3.1	8.9	2.16	1.33	3.9	13.2	2.65	1.29	4.8	18.7	
	29	1.30	1.30	2.3	4.6	1.71	1.46	3.1	8.9	2.15	1.42	3.9	13.1	2.65	1.37	4.8	18.6	
	30	1.30	1.30	2.3	4.5	1.71	1.55	3.1	8.8	2.15	1.50	3.9	13.1	2.64	1.45	4.7	18.6	

Note

- 1. TC : Total capacity, SHC : Sensible Heat Capacity
- 2. Performances are based on the following conditions :
 - 1) Cooling
 - Condition A : Inlet/Outlet Water Temp. 7°C / 12°C, Indoor Air Temp. 27°CDB / 19°CWB
 - Condition B : Inlet/Outlet Water Temp. 10°C / 15°C, Indoor Air Temp. 27°CDB / 19°CWB
 - Condition C : Inlet/Outlet Water Temp. 7°C / 12°C, Indoor Air Temp. 25°CDB / 17.9°CWB
 - Condition D : Inlet/Outlet Water Temp. 14°C / 18°C, Indoor Air Temp. 26°CDB / 18°CWB
- 3. Above capacity tables shows representative values according to the change in temperature or water flow rate, etc., it may vary depending on the installation conditions and the surrounding environment.

6. Capacity Tables

Inlet Water Temp. (°C)	Water Temp Difference (°C)	Air Temp (°C DB)	Air Temp(17°C WB)				Air Temp(19°C WB)				Air Temp(21°C WB)				Air Temp(23°C WB)			
			TC (kW)	SHC (kW)	Water Flow Rate (LPM)	Pressure Drop (kPa)	TC (kW)	SHC (kW)	Water Flow Rate (LPM)	Pressure Drop (kPa)	TC (kW)	SHC (kW)	Water Flow Rate (LPM)	Pressure Drop (kPa)	TC (kW)	SHC (kW)	Water Flow Rate (LPM)	Pressure Drop (kPa)
9	4	24	1.14	1.02	4.1	14.5	1.55	0.97	5.5	24.3	1.99	0.93	7.1	37.4	2.48	0.88	8.9	54.7
		25	1.14	1.10	4.1	14.5	1.54	1.06	5.5	24.2	1.99	1.01	7.1	37.3	2.48	0.96	8.9	54.6
		26	1.14	1.14	4.1	14.4	1.54	1.14	5.5	24.1	1.98	1.09	7.1	37.2	2.47	1.05	8.9	54.4
		27	1.14	1.14	4.1	14.4	1.54	1.22	5.5	24.0	1.98	1.18	7.1	37.1	2.47	1.13	8.9	54.3
		28	1.13	1.13	4.1	14.3	1.54	1.31	5.5	24.0	1.98	1.26	7.1	37.0	2.47	1.22	8.9	54.2
		29	1.13	1.13	4.1	14.3	1.53	1.39	5.5	23.9	1.97	1.35	7.1	36.9	2.46	1.30	8.8	54.1
	30	1.13	1.13	4.1	14.2	1.53	1.48	5.5	23.8	1.97	1.43	7.1	36.8	2.46	1.38	8.8	53.9	
	5	24	1.11	1.01	3.2	9.5	1.52	0.96	4.4	16.1	1.96	0.92	5.6	24.9	2.45	0.87	7.0	36.4
		25	1.11	1.09	3.2	9.5	1.51	1.05	4.3	16.0	1.96	1.00	5.6	24.8	2.45	0.95	7.0	36.3
		26	1.11	1.11	3.2	9.5	1.51	1.13	4.3	16.0	1.95	1.08	5.6	24.7	2.44	1.04	7.0	36.3
		27	1.11	1.11	3.2	9.4	1.51	1.21	4.3	15.9	1.95	1.17	5.6	24.7	2.44	1.12	7.0	36.2
		28	1.10	1.10	3.2	9.4	1.51	1.30	4.3	15.9	1.95	1.25	5.6	24.6	2.44	1.20	7.0	36.1
		29	1.10	1.10	3.2	9.4	1.50	1.38	4.3	15.8	1.94	1.33	5.6	24.5	2.43	1.29	7.0	36.0
	30	1.10	1.10	3.2	9.3	1.50	1.46	4.3	15.8	1.94	1.42	5.6	24.5	2.43	1.37	7.0	35.9	
	6	24	1.08	1.00	2.6	6.3	1.49	0.95	3.6	11.4	1.93	0.90	4.6	17.7	2.42	0.86	5.8	26.1
		25	1.08	1.08	2.6	6.3	1.48	1.03	3.5	11.4	1.93	0.99	4.6	17.7	2.41	0.94	5.8	26.0
		26	1.08	1.08	2.6	6.2	1.48	1.12	3.5	11.3	1.92	1.07	4.6	17.6	2.41	1.02	5.8	26.0
		27	1.08	1.08	2.6	6.2	1.48	1.20	3.5	11.3	1.92	1.15	4.6	17.6	2.41	1.11	5.8	25.9
		28	1.08	1.08	2.6	6.2	1.48	1.28	3.5	11.3	1.92	1.24	4.6	17.5	2.40	1.19	5.8	25.8
		29	1.07	1.07	2.6	6.1	1.47	1.37	3.5	11.2	1.91	1.32	4.6	17.5	2.40	1.28	5.8	25.8
	30	1.07	1.07	2.6	6.1	1.47	1.45	3.5	11.2	1.91	1.41	4.6	17.5	2.40	1.36	5.7	25.7	
	7	24	1.06	0.98	2.2	3.4	1.46	0.94	3.0	8.4	1.90	0.89	3.9	13.3	2.39	0.84	4.9	19.6
		25	1.05	1.05	2.2	3.4	1.45	1.02	3.0	8.4	1.89	0.98	3.9	13.3	2.38	0.93	4.9	19.6
		26	1.05	1.05	2.2	3.4	1.45	1.11	3.0	8.4	1.89	1.06	3.9	13.2	2.38	1.01	4.9	19.5
		27	1.05	1.05	2.1	3.3	1.45	1.19	3.0	8.4	1.89	1.14	3.9	13.2	2.38	1.10	4.9	19.5
		28	1.05	1.05	2.1	3.3	1.44	1.27	3.0	8.3	1.89	1.23	3.9	13.1	2.37	1.18	4.9	19.4
		29	1.04	1.04	2.1	3.3	1.44	1.36	3.0	8.3	1.88	1.31	3.9	13.1	2.37	1.26	4.9	19.4
	30	1.04	1.04	2.1	3.3	1.44	1.44	3.0	8.3	1.88	1.39	3.9	13.1	2.37	1.35	4.9	19.3	
	8	24	1.03	0.97	1.8	2.3	1.43	0.93	2.6	6.1	1.87	0.88	3.3	10.3	2.36	0.83	4.2	15.3
		25	1.02	1.02	1.8	2.3	1.42	1.01	2.6	6.0	1.86	0.96	3.3	10.3	2.35	0.92	4.2	15.2
26		1.02	1.02	1.8	2.3	1.42	1.09	2.5	6.0	1.86	1.05	3.3	10.3	2.35	1.00	4.2	15.2	
27		1.02	1.02	1.8	2.3	1.42	1.18	2.5	6.0	1.86	1.13	3.3	10.2	2.35	1.08	4.2	15.2	
28		1.02	1.02	1.8	2.3	1.41	1.26	2.5	5.9	1.85	1.21	3.3	10.2	2.34	1.17	4.2	15.1	
29		1.01	1.01	1.8	2.3	1.41	1.34	2.5	5.9	1.85	1.30	3.3	10.2	2.34	1.25	4.2	15.1	
30	1.01	1.01	1.8	2.3	1.41	1.41	2.5	5.9	1.85	1.38	3.3	10.1	2.34	1.34	4.2	15.1		

Note

1. TC : Total capacity, SHC : Sensible Heat Capacity
2. Performances are based on the following conditions :
 - 1) Cooling
 - Condition A : Inlet/Outlet Water Temp. 7°C / 12°C, Indoor Air Temp. 27°CDB / 19°CWB
 - Condition B : Inlet/Outlet Water Temp. 10°C / 15°C, Indoor Air Temp. 27°CDB / 19°CWB
 - Condition C : Inlet/Outlet Water Temp. 7°C / 12°C, Indoor Air Temp. 25°CDB / 17.9°CWB
 - Condition D : Inlet/Outlet Water Temp. 14°C / 18°C, Indoor Air Temp. 26°CDB / 18°CWB
3. Above capacity tables shows representative values according to the change in temperature or water flow rate, etc., it may vary depending on the installation conditions and the surrounding environment.

6. Capacity Tables

Inlet Water Temp. (°C)	Water Temp Difference (°C)	Air Temp (°C DB)	Air Temp(17°C WB)				Air Temp(19°C WB)				Air Temp(21°C WB)				Air Temp(23°C WB)			
			TC (kW)	SHC (kW)	Water Flow Rate (LPM)	Pressure Drop (kPa)	TC (kW)	SHC (kW)	Water Flow Rate (LPM)	Pressure Drop (kPa)	TC (kW)	SHC (kW)	Water Flow Rate (LPM)	Pressure Drop (kPa)	TC (kW)	SHC (kW)	Water Flow Rate (LPM)	Pressure Drop (kPa)
9	4	24	1.72	1.48	6.2	21.7	2.32	1.43	8.3	36.2	2.98	1.38	10.7	55.9	-	-	-	-
		25	1.72	1.60	6.2	21.6	2.32	1.55	8.3	36.1	2.98	1.50	10.7	55.7	-	-	-	-
		26	1.72	1.72	6.2	21.5	2.31	1.67	8.3	36.0	2.97	1.61	10.7	55.6	-	-	-	-
		27	1.71	1.71	6.1	21.5	2.31	1.78	8.3	35.9	2.97	1.73	10.7	55.5	-	-	-	-
		28	1.71	1.71	6.1	21.4	2.31	1.90	8.3	35.8	2.97	1.85	10.6	55.3	-	-	-	-
		29	1.70	1.70	6.1	21.3	2.30	2.02	8.3	35.7	2.96	1.97	10.6	55.2	-	-	-	-
	30	1.70	1.70	6.1	21.2	2.30	2.14	8.2	35.6	2.96	2.09	10.6	55.1	-	-	-	-	
	5	24	1.68	1.46	4.8	14.2	2.28	1.41	6.5	23.9	2.94	1.36	8.4	37.0	3.66	1.31	10.5	54.2
		25	1.67	1.58	4.8	14.1	2.27	1.53	6.5	23.8	2.93	1.48	8.4	36.9	3.66	1.42	10.5	54.1
		26	1.67	1.67	4.8	14.1	2.27	1.65	6.5	23.7	2.93	1.60	8.4	36.8	3.65	1.54	10.5	54.0
		27	1.67	1.67	4.8	14.0	2.27	1.77	6.5	23.7	2.92	1.71	8.4	36.7	3.65	1.66	10.5	53.9
		28	1.66	1.66	4.8	14.0	2.26	1.88	6.5	23.6	2.92	1.83	8.4	36.6	3.64	1.78	10.5	53.8
		29	1.66	1.66	4.8	13.9	2.26	2.00	6.5	23.5	2.92	1.95	8.4	36.5	3.64	1.90	10.5	53.6
	30	1.66	1.66	4.8	13.9	2.25	2.12	6.5	23.5	2.91	2.07	8.4	36.4	3.64	2.02	10.4	53.5	
	6	24	1.63	1.45	3.9	9.9	2.23	1.39	5.3	16.9	2.89	1.34	6.9	26.3	3.62	1.29	8.7	38.7
		25	1.63	1.56	3.9	9.9	2.23	1.51	5.3	16.9	2.89	1.46	6.9	26.2	3.61	1.41	8.6	38.6
		26	1.63	1.63	3.9	9.9	2.22	1.63	5.3	16.8	2.88	1.58	6.9	26.2	3.61	1.52	8.6	38.5
		27	1.62	1.62	3.9	9.8	2.22	1.75	5.3	16.8	2.88	1.70	6.9	26.1	3.60	1.64	8.6	38.4
		28	1.62	1.62	3.9	9.8	2.22	1.87	5.3	16.7	2.87	1.81	6.9	26.0	3.60	1.76	8.6	38.4
		29	1.62	1.62	3.9	9.8	2.21	1.98	5.3	16.7	2.87	1.93	6.9	26.0	3.59	1.88	8.6	38.3
	30	1.61	1.61	3.9	9.7	2.21	2.10	5.3	16.6	2.87	2.05	6.9	25.9	3.59	2.00	8.6	38.2	
	7	24	1.59	1.43	3.3	7.3	2.19	1.38	4.5	12.6	2.85	1.32	5.8	19.7	3.57	1.27	7.3	29.0
		25	1.59	1.55	3.3	7.3	2.18	1.49	4.5	12.5	2.84	1.44	5.8	19.6	3.57	1.39	7.3	29.0
		26	1.58	1.58	3.2	7.3	2.18	1.61	4.5	12.5	2.84	1.56	5.8	19.6	3.56	1.51	7.3	28.9
		27	1.58	1.58	3.2	7.2	2.18	1.73	4.5	12.4	2.83	1.68	5.8	19.5	3.56	1.62	7.3	28.8
		28	1.58	1.58	3.2	7.2	2.17	1.85	4.5	12.4	2.83	1.80	5.8	19.5	3.55	1.74	7.3	28.8
		29	1.57	1.57	3.2	7.2	2.17	1.97	4.4	12.4	2.82	1.91	5.8	19.4	3.55	1.86	7.3	28.7
	30	1.57	1.57	3.2	7.2	2.16	2.08	4.4	12.3	2.82	2.03	5.8	19.4	3.54	1.98	7.3	28.6	
	8	24	1.55	1.41	2.8	5.5	2.14	1.36	3.8	9.7	2.80	1.30	5.0	15.2	3.52	1.25	6.3	22.6
		25	1.54	1.53	2.8	5.4	2.14	1.48	3.8	9.6	2.80	1.42	5.0	15.2	3.52	1.37	6.3	22.5
26		1.54	1.54	2.8	5.4	2.13	1.59	3.8	9.6	2.79	1.54	5.0	15.1	3.51	1.49	6.3	22.5	
27		1.54	1.54	2.8	5.4	2.13	1.71	3.8	9.6	2.79	1.66	5.0	15.1	3.51	1.61	6.3	22.4	
28		1.53	1.53	2.7	5.4	2.13	1.83	3.8	9.6	2.78	1.78	5.0	15.1	3.51	1.72	6.3	22.4	
29		1.53	1.53	2.7	5.3	2.12	1.95	3.8	9.5	2.78	1.90	5.0	15.0	3.50	1.84	6.3	22.3	
30	1.52	1.52	2.7	5.3	2.12	2.07	3.8	9.5	2.77	2.01	5.0	15.0	3.50	1.96	6.3	22.3		

Note

- TC : Total capacity, SHC : Sensible Heat Capacity
- Performances are based on the following conditions :
 - Cooling
 - Condition A : Inlet/Outlet Water Temp. 7°C / 12°C, Indoor Air Temp. 27°CDB / 19°CWB
 - Condition B : Inlet/Outlet Water Temp. 10°C / 15°C, Indoor Air Temp. 27°CDB / 19°CWB
 - Condition C : Inlet/Outlet Water Temp. 7°C / 12°C, Indoor Air Temp. 25°CDB / 17.9°CWB
 - Condition D : Inlet/Outlet Water Temp. 14°C / 18°C, Indoor Air Temp. 26°CDB / 18°CWB
- Above capacity tables shows representative values according to the change in temperature or water flow rate, etc., it may vary depending on the installation conditions and the surrounding environment.

6. Capacity Tables

◆ WF4A032CG0A

Inlet Water Temp. (°C)	Water Temp Difference (°C)	Air Temp (°C DB)	Air Temp(17°C WB)				Air Temp(19°C WB)				Air Temp(21°C WB)				Air Temp(23°C WB)				
			TC (kW)	SHC (kW)	Water Flow Rate (LPM)	Pressure Drop (kPa)	TC (kW)	SHC (kW)	Water Flow Rate (LPM)	Pressure Drop (kPa)	TC (kW)	SHC (kW)	Water Flow Rate (LPM)	Pressure Drop (kPa)	TC (kW)	SHC (kW)	Water Flow Rate (LPM)	Pressure Drop (kPa)	
5	4	24	3.02	2.21	10.8	63.6	-	-	-	-	-	-	-	-	-	-	-	-	
		25	3.02	2.35	10.8	63.4	-	-	-	-	-	-	-	-	-	-	-	-	
		26	3.01	2.50	10.8	63.3	-	-	-	-	-	-	-	-	-	-	-	-	
		27	3.01	2.64	10.8	63.1	-	-	-	-	-	-	-	-	-	-	-	-	
		28	3.00	2.79	10.8	63.0	-	-	-	-	-	-	-	-	-	-	-	-	
		29	3.00	2.93	10.8	62.8	-	-	-	-	-	-	-	-	-	-	-	-	
	30	3.00	3.00	10.8	62.7	-	-	-	-	-	-	-	-	-	-	-	-		
	5	5	24	2.97	2.19	8.5	42.0	3.70	2.12	10.6	61.5	-	-	-	-	-	-	-	-
			25	2.97	2.33	8.5	41.9	3.70	2.26	10.6	61.3	-	-	-	-	-	-	-	-
			26	2.97	2.48	8.5	41.8	3.70	2.40	10.6	61.2	-	-	-	-	-	-	-	-
			27	2.96	2.62	8.5	41.7	3.69	2.55	10.6	61.1	-	-	-	-	-	-	-	-
			28	2.96	2.77	8.5	41.6	3.69	2.69	10.6	60.9	-	-	-	-	-	-	-	-
			29	2.95	2.91	8.5	41.5	3.68	2.84	10.6	60.8	-	-	-	-	-	-	-	-
	30	2.95	2.95	8.5	41.4	3.68	2.98	10.6	60.7	-	-	-	-	-	-	-	-		
	6	6	24	2.93	2.17	7.0	29.9	3.66	2.10	8.7	43.8	4.46	2.02	10.7	61.8	-	-	-	-
			25	2.92	2.31	7.0	29.8	3.65	2.24	8.7	43.7	4.45	2.17	10.7	61.7	-	-	-	-
			26	2.92	2.46	7.0	29.7	3.65	2.38	8.7	43.6	4.45	2.31	10.6	61.6	-	-	-	-
			27	2.91	2.60	7.0	29.7	3.64	2.53	8.7	43.5	4.44	2.46	10.6	61.4	-	-	-	-
			28	2.91	2.74	7.0	29.6	3.64	2.67	8.7	43.4	4.44	2.60	10.6	61.3	-	-	-	-
			29	2.91	2.89	7.0	29.5	3.63	2.82	8.7	43.4	4.43	2.74	10.6	61.2	-	-	-	-
	30	2.90	2.90	6.9	29.4	3.63	2.96	8.7	43.3	4.43	2.89	10.6	61.1	-	-	-	-		
	7	7	24	2.88	2.15	5.9	22.3	3.61	2.07	7.4	32.8	4.41	2.00	9.0	46.4	5.29	1.93	10.9	63.7
			25	2.88	2.29	5.9	22.3	3.60	2.22	7.4	32.8	4.41	2.15	9.0	46.3	5.29	2.07	10.9	63.6
			26	2.87	2.44	5.9	22.2	3.60	2.36	7.4	32.7	4.40	2.29	9.0	46.2	5.28	2.22	10.8	63.5
			27	2.87	2.58	5.9	22.1	3.59	2.51	7.4	32.6	4.40	2.43	9.0	46.1	5.28	2.36	10.8	63.4
			28	2.86	2.72	5.9	22.1	3.59	2.65	7.4	32.6	4.39	2.58	9.0	46.1	5.27	2.51	10.8	63.2
			29	2.86	2.86	5.9	22.0	3.59	2.80	7.4	32.5	4.38	2.72	9.0	46.0	5.27	2.65	10.8	63.1
	30	2.86	2.86	5.9	22.0	3.58	2.94	7.3	32.4	4.38	2.87	9.0	45.9	5.26	2.79	10.8	63.0		
	8	8	24	2.83	2.13	5.1	17.3	3.56	2.05	6.4	25.5	4.36	1.98	7.8	36.2	5.24	1.91	9.4	49.7
			25	2.83	2.27	5.1	17.2	3.56	2.20	6.4	25.5	4.36	2.12	7.8	36.1	5.24	2.05	9.4	49.6
26			2.82	2.41	5.1	17.2	3.55	2.34	6.4	25.4	4.35	2.27	7.8	36.0	5.23	2.20	9.4	49.5	
27			2.82	2.56	5.1	17.1	3.55	2.49	6.4	25.3	4.35	2.41	7.8	35.9	5.23	2.34	9.4	49.4	
28			2.82	2.70	5.1	17.1	3.54	2.63	6.4	25.3	4.34	2.56	7.8	35.9	5.22	2.48	9.4	49.3	
29			2.81	2.81	5.0	17.0	3.54	2.77	6.3	25.2	4.34	2.70	7.8	35.8	5.22	2.63	9.4	49.3	
30	2.81	2.81	5.0	17.0	3.53	2.92	6.3	25.2	4.33	2.85	7.8	35.7	5.21	2.77	9.4	49.2			
6	4	24	2.78	2.10	10.0	55.2	-	-	-	-	-	-	-	-	-	-	-	-	
		25	2.78	2.25	10.0	55.0	-	-	-	-	-	-	-	-	-	-	-	-	
		26	2.78	2.39	10.0	54.9	-	-	-	-	-	-	-	-	-	-	-	-	
		27	2.77	2.54	9.9	54.7	-	-	-	-	-	-	-	-	-	-	-	-	
		28	2.77	2.68	9.9	54.6	-	-	-	-	-	-	-	-	-	-	-	-	
		29	2.76	2.76	9.9	54.5	-	-	-	-	-	-	-	-	-	-	-	-	
	30	2.76	2.76	9.9	54.3	-	-	-	-	-	-	-	-	-	-	-	-		
	5	5	24	2.74	2.08	7.9	36.4	3.46	2.01	9.9	54.7	4.26	1.94	12.2	78.4	-	-	-	-
			25	2.73	2.23	7.8	36.3	3.46	2.15	9.9	54.5	4.26	2.08	12.2	78.3	-	-	-	-
			26	2.73	2.37	7.8	36.2	3.45	2.30	9.9	54.4	4.25	2.23	12.2	78.1	-	-	-	-
			27	2.72	2.52	7.8	36.1	3.45	2.44	9.9	54.3	4.25	2.37	12.2	77.9	-	-	-	-
			28	2.72	2.66	7.8	36.0	3.44	2.59	9.9	54.2	4.24	2.52	12.2	77.8	-	-	-	-
			29	2.72	2.72	7.8	35.9	3.44	2.73	9.9	54.0	4.24	2.66	12.2	77.6	-	-	-	-
	30	2.71	2.71	7.8	35.8	3.43	2.88	9.9	53.9	4.23	2.80	12.1	77.4	-	-	-	-		
	6	6	24	2.69	2.06	6.4	25.8	3.41	1.99	8.2	38.9	4.21	1.92	10.1	56.0	5.09	1.84	12.2	77.8
			25	2.68	2.21	6.4	25.7	3.41	2.13	8.2	38.8	4.21	2.06	10.1	55.9	5.09	1.99	12.2	77.7
			26	2.68	2.35	6.4	25.7	3.40	2.28	8.1	38.7	4.20	2.21	10.1	55.7	5.08	2.13	12.2	77.5
			27	2.68	2.50	6.4	25.6	3.40	2.42	8.1	38.6	4.20	2.35	10.0	55.6	5.08	2.28	12.1	77.4
			28	2.67	2.64	6.4	25.5	3.39	2.57	8.1	38.6	4.19	2.49	10.0	55.5	5.07	2.42	12.1	77.2
			29	2.67	2.67	6.4	25.5	3.39	2.71	8.1	38.5	4.19	2.64	10.0	55.4	5.06	2.57	12.1	77.1
	30	2.66	2.66	6.4	25.4	3.39	2.86	8.1	38.4	4.18	2.78	10.0	55.3	5.06	2.71	12.1	76.9		
	7	7	24	2.64	2.04	5.4	19.2	3.36	1.97	6.9	29.1	4.16	1.90	8.5	42.0	5.04	1.82	10.3	58.5
			25	2.64	2.19	5.4	19.2	3.36	2.11	6.9	29.0	4.16	2.04	8.5	41.9	5.04	1.97	10.3	58.4
			26	2.63	2.33	5.4	19.1	3.35	2.26	6.9	29.0	4.15	2.18	8.5	41.8	5.03	2.11	10.3	58.3
			27	2.63	2.47	5.4	19.1	3.35	2.40	6.9	28.9	4.15	2.33	8.5	41.7	5.02	2.26	10.3	58.2
			28	2.62	2.62	5.4	19.0	3.35	2.55	6.9	28.8	4.14	2.47	8.5	41.6	5.02	2.40	10.3	58.1
			29	2.62	2.62	5.4	19.0	3.34	2.69	6.9	28.8	4.14	2.62	8.5	41.5	5.01	2.54	10.3	57.9
	30	2.61	2.61	5.4	18.9	3.34	2.83	6.8	28.7	4.13	2.76	8.5	41.5	5.01	2.69	10.3	57.8		
	8	8	24	2.59	2.02	4.6	14.8	3.31	1.95	5.9	22.6	4.11	1.87	7.4	32.7	4.99	1.80	9.0	45.6
			25	2.59	2.16	4.6	14.8	3.31	2.09	5.9	22.5	4.11	2.02	7.4	32.6	4.98	1.95	8.9	45.5
26			2.58	2.31	4.6	14.8	3.30	2.24	5.9	22.5	4.10	2.16	7.4	32.5	4.98	2.09	8.9	45.4	
27			2.58	2.45	4.6	14.7	3.30	2.38	5.9	22.4	4.10	2.31	7.3	32.5	4.97	2.23	8.9	45.3	
28			2.57	2.57	4.6	14.7	3.30	2.52	5.9	22.4	4.09	2.45	7.3	32.4	4.97	2.38	8.9	45.3	
29			2.57	2.57	4.6	14.6	3.29	2.67	5.9	22.3	4.09	2.60	7.3	32.3	4.96	2.52	8.9	45.2	
30	2.57	2.57	4.6	14.6	3.29	2.81	5.9	22.2	4.08	2.74	7.3	32.2	4.96	2.67	8.9	45.1			

Note

- TC : Total capacity, SHC : Sensible Heat Capacity
- Performances are based on the following conditions :
 - Cooling
 - Condition A : Inlet/Outlet Water Temp. 7°C / 12°C, Indoor Air Temp. 27°CDB / 19°CWB
 - Condition B : Inlet/Outlet Water Temp. 10°C / 15°C, Indoor Air Temp. 27°CDB / 19°CWB
 - Condition C : Inlet/Outlet Water Temp. 7°C / 12°C, Indoor Air Temp. 25°CDB / 17.9°CWB
 - Condition D : Inlet/Outlet Water Temp. 14°C / 18°C, Indoor Air Temp. 26°CDB / 18°CWB
- Above capacity tables shows representative values according to the change in temperature or water flow rate, etc., it may vary depending on the installation conditions and the surrounding environment.

6. Capacity Tables

Inlet Water Temp. (°C)	Water Temp Difference (°C)	Air Temp (°C DB)	Air Temp(17°C WB)				Air Temp(19°C WB)				Air Temp(21°C WB)				Air Temp(23°C WB)			
			TC (kW)	SHC (kW)	Water Flow Rate (LPM)	Pressure Drop (kPa)	TC (kW)	SHC (kW)	Water Flow Rate (LPM)	Pressure Drop (kPa)	TC (kW)	SHC (kW)	Water Flow Rate (LPM)	Pressure Drop (kPa)	TC (kW)	SHC (kW)	Water Flow Rate (LPM)	Pressure Drop (kPa)
7	4	24	2.54	2.00	9.1	47.1	3.26	1.93	11.7	72.7	-	-	-	-	-	-	-	-
		25	2.54	2.14	9.1	47.0	3.26	2.07	11.7	72.5	-	-	-	-	-	-	-	-
		26	2.53	2.29	9.1	46.8	3.25	2.21	11.7	72.3	-	-	-	-	-	-	-	-
		27	2.53	2.43	9.1	46.7	3.25	2.36	11.7	72.2	-	-	-	-	-	-	-	-
		28	2.53	2.53	9.1	46.6	3.25	2.50	11.6	72.0	-	-	-	-	-	-	-	-
		29	2.52	2.52	9.0	46.5	3.24	2.65	11.6	71.8	-	-	-	-	-	-	-	-
	30	2.52	2.52	9.0	46.3	3.24	2.79	11.6	71.6	-	-	-	-	-	-	-	-	
	5	24	2.49	1.98	7.2	31.0	3.21	1.90	9.2	48.1	4.01	1.83	11.5	70.5	-	-	-	-
		25	2.49	2.12	7.1	30.9	3.21	2.05	9.2	47.9	4.00	1.98	11.5	70.3	-	-	-	-
		26	2.48	2.27	7.1	30.8	3.20	2.19	9.2	47.8	4.00	2.12	11.5	70.2	-	-	-	-
		27	2.48	2.41	7.1	30.7	3.20	2.34	9.2	47.7	3.99	2.27	11.5	70.0	-	-	-	-
		28	2.48	2.48	7.1	30.7	3.20	2.48	9.2	47.6	3.99	2.41	11.4	69.9	-	-	-	-
		29	2.47	2.47	7.1	30.6	3.19	2.63	9.2	47.5	3.98	2.55	11.4	69.7	-	-	-	-
	30	2.47	2.47	7.1	30.5	3.19	2.77	9.1	47.3	3.98	2.70	11.4	69.6	-	-	-	-	
	6	24	2.44	1.96	5.8	21.9	3.16	1.88	7.6	34.1	3.96	1.81	9.5	50.3	4.83	1.74	11.6	71.1
		25	2.44	2.10	5.8	21.9	3.16	2.03	7.6	34.1	3.95	1.95	9.5	50.1	4.83	1.88	11.6	70.9
		26	2.43	2.24	5.8	21.8	3.15	2.17	7.5	34.0	3.95	2.10	9.4	50.0	4.82	2.03	11.5	70.8
		27	2.43	2.39	5.8	21.7	3.15	2.32	7.5	33.9	3.94	2.24	9.4	49.9	4.82	2.17	11.5	70.6
		28	2.43	2.43	5.8	21.7	3.14	2.46	7.5	33.8	3.94	2.39	9.4	49.8	4.81	2.32	11.5	70.5
		29	2.42	2.42	5.8	21.6	3.14	2.61	7.5	33.7	3.93	2.53	9.4	49.7	4.80	2.46	11.5	70.3
	30	2.42	2.42	5.8	21.5	3.14	2.75	7.5	33.6	3.93	2.68	9.4	49.6	4.80	2.60	11.5	70.2	
	7	24	2.39	1.94	4.9	16.3	3.11	1.86	6.4	25.5	3.91	1.79	8.0	37.6	4.78	1.72	9.8	53.4
		25	2.39	2.08	4.9	16.2	3.11	2.01	6.4	25.4	3.90	1.93	8.0	37.6	4.77	1.86	9.8	53.3
		26	2.38	2.22	4.9	16.2	3.10	2.15	6.4	25.4	3.90	2.08	8.0	37.5	4.77	2.01	9.8	53.2
		27	2.38	2.37	4.9	16.1	3.10	2.30	6.4	25.3	3.89	2.22	8.0	37.4	4.76	2.15	9.8	53.0
		28	2.38	2.38	4.9	16.1	3.09	2.44	6.3	25.2	3.89	2.37	8.0	37.3	4.76	2.29	9.8	52.9
		29	2.37	2.37	4.9	16.0	3.09	2.58	6.3	25.2	3.88	2.51	8.0	37.2	4.75	2.44	9.7	52.8
	30	2.37	2.37	4.9	16.0	3.08	2.73	6.3	25.1	3.87	2.66	7.9	37.1	4.75	2.58	9.7	52.7	
	8	24	2.34	1.91	4.2	12.5	3.06	1.84	5.5	19.7	3.85	1.77	6.9	29.2	4.73	1.69	8.5	41.6
		25	2.34	2.06	4.2	12.5	3.06	1.99	5.5	19.7	3.85	1.91	6.9	29.2	4.72	1.84	8.5	41.5
26		2.33	2.20	4.2	12.4	3.05	2.13	5.5	19.6	3.84	2.06	6.9	29.1	4.72	1.98	8.5	41.4	
27		2.33	2.33	4.2	12.4	3.05	2.27	5.5	19.6	3.84	2.20	6.9	29.0	4.71	2.13	8.5	41.3	
28		2.33	2.33	4.2	12.4	3.04	2.42	5.5	19.5	3.83	2.35	6.9	29.0	4.70	2.27	8.4	41.2	
29		2.32	2.32	4.2	12.3	3.04	2.56	5.5	19.5	3.83	2.49	6.9	28.9	4.70	2.42	8.4	41.1	
30	2.32	2.32	4.2	12.3	3.03	2.71	5.4	19.4	3.82	2.64	6.9	28.8	4.69	2.56	8.4	41.0		
8	4	24	2.29	1.89	8.2	39.4	3.01	1.82	10.8	63.2	-	-	-	-	-	-	-	
		25	2.29	2.04	8.2	39.3	3.01	1.96	10.8	63.0	-	-	-	-	-	-	-	
		26	2.28	2.18	8.2	39.2	3.00	2.11	10.8	62.8	-	-	-	-	-	-	-	
		27	2.28	2.28	8.2	39.1	3.00	2.25	10.8	62.7	-	-	-	-	-	-	-	
		28	2.28	2.28	8.2	38.9	2.99	2.40	10.7	62.5	-	-	-	-	-	-	-	
		29	2.27	2.27	8.2	38.8	2.99	2.54	10.7	62.3	-	-	-	-	-	-	-	
	30	2.27	2.27	8.1	38.7	2.98	2.69	10.7	62.1	-	-	-	-	-	-	-		
	5	24	2.24	1.87	6.4	25.8	2.96	1.80	8.5	41.7	3.75	1.73	10.8	62.8	-	-	-	-
		25	2.24	2.02	6.4	25.8	2.95	1.94	8.5	41.5	3.74	1.87	10.7	62.6	-	-	-	-
		26	2.23	2.16	6.4	25.7	2.95	2.09	8.5	41.4	3.74	2.01	10.7	62.5	-	-	-	-
		27	2.23	2.23	6.4	25.6	2.94	2.23	8.5	41.3	3.73	2.16	10.7	62.3	-	-	-	-
		28	2.23	2.23	6.4	25.5	2.94	2.38	8.4	41.2	3.73	2.30	10.7	62.2	-	-	-	-
		29	2.22	2.22	6.4	25.4	2.94	2.52	8.4	41.1	3.72	2.45	10.7	62.0	-	-	-	-
	30	2.22	2.22	6.4	25.4	2.93	2.67	8.4	41.0	3.72	2.59	10.7	61.9	-	-	-	-	
	6	24	2.19	1.85	5.2	18.2	2.91	1.78	7.0	29.5	3.70	1.70	8.8	44.7	4.57	1.63	10.9	64.4
		25	2.19	1.99	5.2	18.1	2.90	1.92	6.9	29.4	3.69	1.85	8.8	44.5	4.56	1.78	10.9	64.3
		26	2.18	2.14	5.2	18.1	2.90	2.07	6.9	29.4	3.69	1.99	8.8	44.4	4.56	1.92	10.9	64.1
		27	2.18	2.18	5.2	18.0	2.89	2.21	6.9	29.3	3.68	2.14	8.8	44.3	4.55	2.07	10.9	64.0
		28	2.17	2.17	5.2	18.0	2.89	2.36	6.9	29.2	3.68	2.28	8.8	44.2	4.54	2.21	10.9	63.9
		29	2.17	2.17	5.2	17.9	2.88	2.50	6.9	29.1	3.67	2.43	8.8	44.1	4.54	2.35	10.9	63.7
	30	2.17	2.17	5.2	17.8	2.88	2.64	6.9	29.0	3.67	2.57	8.8	44.0	4.53	2.50	10.8	63.6	
	7	24	2.14	1.83	4.4	13.4	2.85	1.76	5.9	22.0	3.64	1.68	7.5	33.4	4.51	1.61	9.3	48.3
		25	2.14	1.97	4.4	13.4	2.85	1.90	5.8	21.9	3.64	1.83	7.5	33.3	4.51	1.75	9.2	48.2
		26	2.13	2.12	4.4	13.4	2.85	2.05	5.8	21.9	3.63	1.97	7.4	33.2	4.50	1.90	9.2	48.1
		27	2.13	2.13	4.4	13.3	2.84	2.19	5.8	21.8	3.63	2.12	7.4	33.1	4.50	2.04	9.2	48.0
		28	2.12	2.12	4.4	13.3	2.84	2.33	5.8	21.7	3.62	2.26	7.4	33.1	4.49	2.19	9.2	47.9
		29	2.12	2.12	4.3	13.2	2.83	2.48	5.8	21.7	3.62	2.41	7.4	33.0	4.48	2.33	9.2	47.8
	30	2.11	2.11	4.3	13.2	2.83	2.62	5.8	21.6	3.61	2.55	7.4	32.9	4.48	2.48	9.2	47.7	
	8	24	2.09	1.81	3.7	10.3	2.80	1.73	5.0	17.0	3.59	1.66	6.4	25.9	4.46	1.59	8.0	37.6
		25	2.08	1.95	3.7	10.3	2.80	1.88	5.0	16.9	3.58	1.81	6.4	25.8	4.45	1.73	8.0	37.5
26		2.08	2.08	3.7	10.2	2.79	2.02	5.0	16.9	3.58	1.95	6.4	25.8	4.45	1.88	8.0	37.4	
27		2.08	2.08	3.7	10.2	2.79	2.17	5.0	16.8	3.57	2.10	6.4	25.7	4.44	2.02	8.0	37.3	
28		2.07	2.07	3.7	10.2	2.78	2.31	5.0	16.8	3.57	2.24	6.4	25.6	4.44	2.17	8.0	37.2	
29		2.07	2.07	3.7	10.1	2.78	2.46	5.0	16.7	3.56	2.39	6.4	25.6	4.43	2.31	8.0	37.2	
30	2.06	2.06	3.7	10.1	2.77	2.60	5.0	16.7	3.56	2.53	6.4	25.5	4.42	2.46	7.9	37.1		

Note

- TC : Total capacity, SHC : Sensible Heat Capacity
- Performances are based on the following conditions :
 - Cooling
 - Condition A : Inlet/Outlet Water Temp. 7°C / 12°C, Indoor Air Temp. 27°CDB / 19°CWB
 - Condition B : Inlet/Outlet Water Temp. 10°C / 15°C, Indoor Air Temp. 27°CDB / 19°CWB
 - Condition C : Inlet/Outlet Water Temp. 7°C / 12°C, Indoor Air Temp. 25°CDB / 17.9°CWB
 - Condition D : Inlet/Outlet Water Temp. 14°C / 18°C, Indoor Air Temp. 26°CDB / 18°CWB
- Above capacity tables shows representative values according to the change in temperature or water flow rate, etc., it may vary depending on the installation conditions and the surrounding environment.

6. Capacity Tables

Inlet Water Temp. (°C)	Water Temp Difference (°C)	Air Temp (°C DB)	Air Temp(17°C WB)				Air Temp(19°C WB)				Air Temp(21°C WB)				Air Temp(23°C WB)			
			TC (kW)	SHC (kW)	Water Flow Rate (LPM)	Pressure Drop (kPa)	TC (kW)	SHC (kW)	Water Flow Rate (LPM)	Pressure Drop (kPa)	TC (kW)	SHC (kW)	Water Flow Rate (LPM)	Pressure Drop (kPa)	TC (kW)	SHC (kW)	Water Flow Rate (LPM)	Pressure Drop (kPa)
9	4	24	2.04	1.79	7.3	32.2	2.75	1.71	9.9	54.0	-	-	-	-	-	-	-	-
		25	2.03	1.93	7.3	32.0	2.75	1.86	9.9	53.8	-	-	-	-	-	-	-	-
		26	2.03	2.03	7.3	31.9	2.74	2.00	9.8	53.7	-	-	-	-	-	-	-	-
		27	2.02	2.02	7.3	31.8	2.74	2.15	9.8	53.5	-	-	-	-	-	-	-	-
		28	2.02	2.02	7.2	31.7	2.73	2.29	9.8	53.4	-	-	-	-	-	-	-	-
		29	2.02	2.02	7.2	31.6	2.73	2.44	9.8	53.2	-	-	-	-	-	-	-	-
	30	2.01	2.01	7.2	31.5	2.72	2.58	9.8	53.0	-	-	-	-	-	-	-	-	
	5	24	1.98	1.77	5.7	21.0	2.70	1.69	7.7	35.5	3.48	1.62	10.0	55.2	-	-	-	-
		25	1.98	1.91	5.7	20.9	2.69	1.84	7.7	35.4	3.48	1.76	10.0	55.1	-	-	-	-
		26	1.98	1.98	5.7	20.8	2.69	1.98	7.7	35.3	3.47	1.91	10.0	54.9	-	-	-	-
		27	1.97	1.97	5.7	20.8	2.68	2.13	7.7	35.2	3.47	2.05	10.0	54.8	-	-	-	-
		28	1.97	1.97	5.7	20.7	2.68	2.27	7.7	35.1	3.46	2.20	9.9	54.6	-	-	-	-
		29	1.96	1.96	5.6	20.6	2.67	2.42	7.7	35.0	3.46	2.34	9.9	54.5	-	-	-	-
	30	1.96	1.96	5.6	20.5	2.67	2.56	7.7	34.9	3.45	2.49	9.9	54.4	-	-	-	-	
	6	24	1.93	1.74	4.6	14.7	2.64	1.67	6.3	25.1	3.43	1.60	8.2	39.2	4.29	1.52	10.3	57.9
		25	1.93	1.89	4.6	14.6	2.64	1.82	6.3	25.0	3.42	1.74	8.2	39.1	4.29	1.67	10.3	57.7
		26	1.92	1.92	4.6	14.6	2.63	1.96	6.3	24.9	3.42	1.89	8.2	39.0	4.28	1.81	10.2	57.6
		27	1.92	1.92	4.6	14.5	2.63	2.10	6.3	24.9	3.41	2.03	8.2	38.9	4.28	1.96	10.2	57.5
		28	1.92	1.92	4.6	14.5	2.62	2.25	6.3	24.8	3.41	2.18	8.2	38.8	4.27	2.10	10.2	57.3
		29	1.91	1.91	4.6	14.4	2.62	2.39	6.3	24.7	3.40	2.32	8.1	38.7	4.26	2.25	10.2	57.2
	30	1.91	1.91	4.6	14.4	2.62	2.54	6.3	24.6	3.40	2.47	8.1	38.6	4.26	2.39	10.2	57.1	
	7	24	1.88	1.72	3.9	10.8	2.59	1.65	5.3	18.6	3.37	1.58	6.9	29.3	4.24	1.50	8.7	43.3
		25	1.88	1.88	3.8	10.8	2.59	1.79	5.3	18.6	3.37	1.72	6.9	29.2	4.23	1.65	8.7	43.2
		26	1.87	1.87	3.8	10.7	2.58	1.94	5.3	18.5	3.36	1.87	6.9	29.1	4.23	1.79	8.7	43.1
		27	1.87	1.87	3.8	10.7	2.58	2.08	5.3	18.4	3.36	2.01	6.9	29.0	4.22	1.94	8.7	43.0
		28	1.86	1.86	3.8	10.6	2.57	2.23	5.3	18.4	3.35	2.16	6.9	28.9	4.22	2.08	8.6	42.9
		29	1.86	1.86	3.8	10.6	2.57	2.37	5.3	18.3	3.35	2.30	6.9	28.9	4.21	2.23	8.6	42.8
	30	1.85	1.85	3.8	10.6	2.56	2.52	5.3	18.3	3.34	2.45	6.9	28.8	4.20	2.37	8.6	42.7	
	8	24	1.83	1.70	3.3	8.2	2.54	1.63	4.6	14.3	3.32	1.56	6.0	22.6	4.18	1.48	7.5	33.6
		25	1.82	1.82	3.3	8.2	2.53	1.77	4.5	14.3	3.31	1.70	5.9	22.6	4.18	1.63	7.5	33.6
26		1.82	1.82	3.3	8.1	2.53	1.92	4.5	14.2	3.31	1.84	5.9	22.5	4.17	1.77	7.5	33.5	
27		1.81	1.81	3.3	8.1	2.52	2.06	4.5	14.2	3.30	1.99	5.9	22.4	4.16	1.92	7.5	33.4	
28		1.81	1.81	3.2	8.1	2.52	2.21	4.5	14.1	3.30	2.13	5.9	22.4	4.16	2.06	7.5	33.3	
29		1.81	1.81	3.2	8.1	2.51	2.35	4.5	14.1	3.29	2.28	5.9	22.3	4.15	2.21	7.5	33.3	
30	1.80	1.80	3.2	8.0	2.51	2.51	4.5	14.0	3.29	2.42	5.9	22.3	4.15	2.35	7.4	33.2		

Note

- TC : Total capacity, SHC : Sensible Heat Capacity
- Performances are based on the following conditions :
 - Cooling
 - Condition A : Inlet/Outlet Water Temp. 7°C / 12°C, Indoor Air Temp. 27°CDB / 19°CWB
 - Condition B : Inlet/Outlet Water Temp. 10°C / 15°C, Indoor Air Temp. 27°CDB / 19°CWB
 - Condition C : Inlet/Outlet Water Temp. 7°C / 12°C, Indoor Air Temp. 25°CDB / 17.9°CWB
 - Condition D : Inlet/Outlet Water Temp. 14°C / 18°C, Indoor Air Temp. 26°CDB / 18°CWB
- Above capacity tables shows representative values according to the change in temperature or water flow rate, etc., it may vary depending on the installation conditions and the surrounding environment.

6. Capacity Tables

Inlet Water Temp. (°C)	Water Temp Difference (°C)	Air Temp (°C DB)	Air Temp(17°C WB)				Air Temp(19°C WB)				Air Temp(21°C WB)				Air Temp(23°C WB)			
			TC (kW)	SHC (kW)	Water Flow Rate (LPM)	Pressure Drop (kPa)	TC (kW)	SHC (kW)	Water Flow Rate (LPM)	Pressure Drop (kPa)	TC (kW)	SHC (kW)	Water Flow Rate (LPM)	Pressure Drop (kPa)	TC (kW)	SHC (kW)	Water Flow Rate (LPM)	Pressure Drop (kPa)
7	4	24	3.23	2.92	11.6	42.7	4.19	2.70	15.0	67.0	-	-	-	-	-	-	-	-
		25	3.23	3.16	11.6	42.5	4.18	2.95	15.0	66.8	-	-	-	-	-	-	-	-
		26	3.22	3.22	11.6	42.3	4.17	3.19	15.0	66.6	-	-	-	-	-	-	-	-
		27	3.21	3.21	11.5	42.2	4.17	3.43	15.0	66.3	-	-	-	-	-	-	-	-
		28	3.21	3.21	11.5	42.0	4.16	3.67	14.9	66.1	-	-	-	-	-	-	-	-
		29	3.20	3.20	11.5	41.9	4.15	3.91	14.9	65.9	-	-	-	-	-	-	-	-
	30	3.19	3.19	11.5	41.7	4.14	4.14	14.9	65.7	-	-	-	-	-	-	-	-	
	5	24	3.17	2.89	9.1	28.0	4.12	2.68	11.8	44.1	5.19	2.46	14.9	65.8	-	-	-	-
		25	3.16	3.13	9.1	27.9	4.12	2.92	11.8	44.0	5.18	2.70	14.9	65.7	-	-	-	-
		26	3.16	3.16	9.1	27.8	4.11	3.16	11.8	43.8	5.17	2.95	14.8	65.5	-	-	-	-
		27	3.15	3.15	9.0	27.7	4.10	3.40	11.8	43.7	5.16	3.19	14.8	65.3	-	-	-	-
		28	3.14	3.14	9.0	27.6	4.09	3.65	11.7	43.6	5.15	3.43	14.8	65.1	-	-	-	-
		29	3.14	3.14	9.0	27.4	4.08	3.89	11.7	43.4	5.14	3.67	14.8	64.9	-	-	-	-
	30	3.13	3.13	9.0	27.3	4.08	4.08	11.7	43.3	5.13	3.92	14.7	64.7	-	-	-	-	
	6	24	3.10	2.87	7.4	19.7	4.06	2.65	9.7	31.3	5.12	2.44	12.2	46.8	6.30	2.22	15.1	67.3
		25	3.10	3.10	7.4	19.6	4.05	2.89	9.7	31.2	5.11	2.68	12.2	46.7	6.29	2.46	15.1	67.1
		26	3.09	3.09	7.4	19.6	4.04	3.14	9.7	31.1	5.10	2.92	12.2	46.5	6.28	2.71	15.0	66.9
		27	3.08	3.08	7.4	19.5	4.03	3.38	9.6	30.9	5.09	3.16	12.2	46.4	6.27	2.95	15.0	66.7
		28	3.08	3.08	7.4	19.4	4.02	3.62	9.6	30.8	5.08	3.41	12.2	46.2	6.26	3.19	15.0	66.6
		29	3.07	3.07	7.3	19.3	4.02	3.86	9.6	30.7	5.07	3.65	12.1	46.1	6.25	3.43	15.0	66.4
	30	3.06	3.06	7.3	19.3	4.01	4.01	9.6	30.6	5.06	3.89	12.1	46.0	6.24	3.68	14.9	66.2	
	7	24	3.04	2.84	6.2	14.6	3.99	2.62	8.2	23.3	5.05	2.41	10.3	35.0	6.23	2.19	12.8	50.4
		25	3.03	3.03	6.2	14.5	3.98	2.87	8.2	23.2	5.04	2.65	10.3	34.8	6.22	2.44	12.8	50.2
		26	3.03	3.03	6.2	14.5	3.97	3.11	8.1	23.1	5.03	2.89	10.3	34.7	6.21	2.68	12.7	50.1
		27	3.02	3.02	6.2	14.4	3.96	3.35	8.1	23.0	5.02	3.14	10.3	34.6	6.20	2.92	12.7	50.0
		28	3.01	3.01	6.2	14.4	3.96	3.59	8.1	22.9	5.01	3.38	10.3	34.5	6.19	3.17	12.7	49.8
		29	3.00	3.00	6.2	14.3	3.95	3.84	8.1	22.9	5.00	3.62	10.3	34.4	6.18	3.41	12.7	49.7
	30	3.00	3.00	6.1	14.2	3.94	3.94	8.1	22.8	4.99	3.86	10.2	34.3	6.17	3.65	12.7	49.6	
	8	24	2.97	2.81	5.3	11.2	3.92	2.60	7.0	17.9	4.98	2.38	8.9	27.1	6.16	2.17	11.1	39.1
		25	2.97	2.97	5.3	11.1	3.91	2.84	7.0	17.9	4.97	2.63	8.9	27.0	6.15	2.41	11.0	39.0
26		2.96	2.96	5.3	11.1	3.90	3.08	7.0	17.8	4.96	2.87	8.9	26.9	6.14	2.65	11.0	38.9	
27		2.95	2.95	5.3	11.0	3.90	3.33	7.0	17.8	4.95	3.11	8.9	26.8	6.13	2.90	11.0	38.8	
28		2.95	2.95	5.3	11.0	3.89	3.57	7.0	17.7	4.94	3.35	8.9	26.7	6.12	3.14	11.0	38.7	
29		2.94	2.94	5.3	11.0	3.88	3.81	7.0	17.6	4.93	3.60	8.9	26.7	6.11	3.38	11.0	38.6	
30	2.93	2.93	5.3	10.9	3.87	3.87	7.0	17.6	4.92	3.84	8.8	26.6	6.10	3.62	10.9	38.5		
8	4	24	2.91	2.79	10.4	35.4	3.85	2.57	13.8	57.8	-	-	-	-	-	-	-	
		25	2.90	2.90	10.4	35.3	3.84	2.81	13.8	57.6	-	-	-	-	-	-	-	
		26	2.89	2.89	10.4	35.1	3.84	3.06	13.8	57.4	-	-	-	-	-	-	-	
		27	2.89	2.89	10.4	35.0	3.83	3.30	13.7	57.2	-	-	-	-	-	-	-	
		28	2.88	2.88	10.3	34.9	3.82	3.54	13.7	57.0	-	-	-	-	-	-	-	
		29	2.87	2.87	10.3	34.7	3.81	3.78	13.7	56.8	-	-	-	-	-	-	-	
	30	2.87	2.87	10.3	34.6	3.81	3.81	13.7	56.6	-	-	-	-	-	-	-		
	5	24	2.84	2.76	8.2	23.2	3.78	2.55	10.9	38.0	4.84	2.33	13.9	58.2	-	-	-	-
		25	2.83	2.83	8.1	23.1	3.78	2.79	10.8	37.9	4.83	2.57	13.9	58.1	6.00	2.36	17.2	85.0
		26	2.83	2.83	8.1	23.0	3.77	3.03	10.8	37.7	4.82	2.82	13.8	57.9	5.99	2.60	17.2	84.7
		27	2.82	2.82	8.1	22.9	3.76	3.27	10.8	37.6	4.81	3.06	13.8	57.7	5.98	2.84	17.2	84.5
		28	2.81	2.81	8.1	22.8	3.75	3.52	10.8	37.5	4.80	3.30	13.8	57.5	5.97	3.09	17.1	84.2
		29	2.81	2.81	8.1	22.7	3.74	3.74	10.7	37.3	4.79	3.54	13.8	57.3	5.96	3.33	17.1	84.0
	30	2.80	2.80	8.0	22.6	3.74	3.74	10.7	37.2	4.78	3.79	13.7	57.2	5.95	3.57	17.1	83.8	
	6	24	2.77	2.73	6.6	16.2	3.71	2.52	8.9	26.9	4.76	2.30	11.4	41.3	5.94	2.09	14.2	60.6
		25	2.77	2.77	6.6	16.2	3.71	2.76	8.9	26.8	4.76	2.55	11.4	41.2	5.93	2.33	14.2	60.4
		26	2.76	2.76	6.6	16.1	3.70	3.00	8.8	26.7	4.75	2.79	11.4	41.1	5.92	2.57	14.2	60.3
		27	2.75	2.75	6.6	16.0	3.69	3.25	8.8	26.6	4.74	3.03	11.3	40.9	5.91	2.82	14.1	60.1
		28	2.75	2.75	6.6	16.0	3.68	3.49	8.8	26.5	4.73	3.27	11.3	40.8	5.90	3.06	14.1	59.9
		29	2.74	2.74	6.6	15.9	3.68	3.68	8.8	26.4	4.72	3.52	11.3	40.7	5.89	3.30	14.1	59.8
	30	2.73	2.73	6.5	15.8	3.67	3.67	8.8	26.3	4.71	3.76	11.3	40.5	5.88	3.55	14.1	59.6	
	7	24	2.71	2.71	5.6	12.0	3.65	2.49	7.5	19.9	4.69	2.28	9.6	30.8	5.86	2.06	12.0	45.3
		25	2.70	2.70	5.5	11.9	3.64	2.74	7.5	19.9	4.68	2.52	9.6	30.7	5.85	2.30	12.0	45.2
		26	2.69	2.69	5.5	11.9	3.63	2.98	7.4	19.8	4.68	2.76	9.6	30.6	5.84	2.55	12.0	45.1
		27	2.69	2.69	5.5	11.8	3.62	3.22	7.4	19.7	4.67	3.01	9.6	30.5	5.83	2.79	12.0	44.9
		28	2.68	2.68	5.5	11.8	3.61	3.46	7.4	19.6	4.66	3.25	9.6	30.4	5.82	3.03	11.9	44.8
		29	2.67	2.67	5.5	11.7	3.61	3.61	7.4	19.6	4.65	3.49	9.5	30.3	5.81	3.28	11.9	44.7
	30	2.67	2.67	5.5	11.7	3.60	3.60	7.4	19.5	4.64	3.73	9.5	30.2	5.80	3.52	11.9	44.6	
	8	24	2.64	2.64	4.7	9.1	3.58	2.47	6.4	15.3	4.62	2.25	8.3	23.8	5.79	2.04	10.4	35.2
		25	2.63	2.63	4.7	9.1	3.57	2.71	6.4	15.3	4.61	2.49	8.3	23.7	5.78	2.28	10.4	35.1
26		2.63	2.63	4.7	9.1	3.56	2.95	6.4	15.2	4.60	2.74	8.3	23.7	5.77	2.52	10.4	35.0	
27		2.62	2.62	4.7	9.0	3.55	3.19	6.4	15.2	4.59	2.98	8.2	23.6	5.76	2.76	10.3	34.9	
28		2.61	2.61	4.7	9.0	3.54	3.44	6.4	15.1	4.59	3.22	8.2	23.5	5.75	3.01	10.3	34.8	
29		2.61	2.61	4.7	8.9	3.54	3.54	6.3	15.0	4.58	3.46	8.2	23.4	5.74	3.25	10.3	34.7	
30	2.60	2.60	4.7	8.9	3.53	3.53	6.3	15.0	4.57	3.71	8.2	23.4	5.73	3.49	10.3	34.6		

Note

- TC : Total capacity, SHC : Sensible Heat Capacity
- Performances are based on the following conditions :
 - Cooling
 - Condition A : Inlet/Outlet Water Temp. 7°C / 12°C, Indoor Air Temp. 27°CDB / 19°CWB
 - Condition B : Inlet/Outlet Water Temp. 10°C / 15°C, Indoor Air Temp. 27°CDB / 19°CWB
 - Condition C : Inlet/Outlet Water Temp. 7°C / 12°C, Indoor Air Temp. 25°CDB / 17.9°CWB
 - Condition D : Inlet/Outlet Water Temp. 14°C / 18°C, Indoor Air Temp. 26°CDB / 18°CWB
- Above capacity tables shows representative values according to the change in temperature or water flow rate, etc., it may vary depending on the installation conditions and the surrounding environment.

6. Capacity Tables

Inlet Water Temp. (°C)	Water Temp Difference (°C)	Air Temp (°C DB)	Air Temp(17°C WB)				Air Temp(19°C WB)				Air Temp(21°C WB)				Air Temp(23°C WB)			
			TC (kW)	SHC (kW)	Water Flow Rate (LPM)	Pressure Drop (kPa)	TC (kW)	SHC (kW)	Water Flow Rate (LPM)	Pressure Drop (kPa)	TC (kW)	SHC (kW)	Water Flow Rate (LPM)	Pressure Drop (kPa)	TC (kW)	SHC (kW)	Water Flow Rate (LPM)	Pressure Drop (kPa)
9	4	24	2.57	2.57	9.2	28.7	3.51	2.44	12.6	49.1	4.55	2.22	16.3	77.3	-	-	-	-
		25	2.57	2.57	9.2	28.6	3.50	2.68	12.6	48.9	4.54	2.47	16.3	77.1	-	-	-	-
		26	2.56	2.56	9.2	28.4	3.49	2.93	12.5	48.7	4.53	2.71	16.3	76.8	-	-	-	-
		27	2.55	2.55	9.2	28.3	3.48	3.17	12.5	48.5	4.52	2.95	16.2	76.5	-	-	-	-
		28	2.55	2.55	9.1	28.2	3.48	3.41	12.5	48.3	4.51	3.20	16.2	76.3	-	-	-	-
		29	2.54	2.54	9.1	28.0	3.47	3.47	12.4	48.1	4.51	3.44	16.2	76.0	-	-	-	-
	30	2.53	2.53	9.1	27.9	3.46	3.46	12.4	47.9	4.50	3.68	16.1	75.8	-	-	-	-	
	5	24	2.51	2.51	7.2	18.6	3.44	2.41	9.9	32.2	4.48	2.20	12.9	50.9	5.64	1.98	16.2	76.2
		25	2.50	2.50	7.2	18.6	3.43	2.66	9.8	32.0	4.47	2.44	12.8	50.7	5.63	2.23	16.2	76.0
		26	2.49	2.49	7.2	18.5	3.42	2.90	9.8	31.9	4.46	2.68	12.8	50.6	5.62	2.47	16.1	75.7
		27	2.48	2.48	7.1	18.4	3.41	3.14	9.8	31.8	4.45	2.93	12.8	50.4	5.61	2.71	16.1	75.5
		28	2.48	2.48	7.1	18.3	3.41	3.41	9.8	31.7	4.44	3.17	12.8	50.2	5.60	2.95	16.1	75.3
		29	2.47	2.47	7.1	18.2	3.40	3.40	9.8	31.5	4.43	3.41	12.7	50.1	5.59	3.20	16.1	75.1
	30	2.46	2.46	7.1	18.1	3.39	3.39	9.7	31.4	4.42	3.66	12.7	49.9	5.58	3.44	16.0	74.8	
	6	24	2.44	2.44	5.8	13.0	3.37	2.39	8.1	22.7	4.40	2.17	10.5	36.0	5.56	1.96	13.3	54.1
		25	2.43	2.43	5.8	13.0	3.36	2.63	8.0	22.6	4.40	2.41	10.5	35.9	5.55	2.20	13.3	54.0
		26	2.42	2.42	5.8	12.9	3.35	2.87	8.0	22.5	4.39	2.66	10.5	35.8	5.54	2.44	13.3	53.8
		27	2.42	2.42	5.8	12.8	3.34	3.12	8.0	22.4	4.38	2.90	10.5	35.7	5.53	2.69	13.2	53.6
		28	2.41	2.41	5.8	12.8	3.33	3.33	8.0	22.3	4.37	3.14	10.5	35.6	5.52	2.93	13.2	53.5
		29	2.40	2.40	5.7	12.7	3.33	3.33	8.0	22.2	4.36	3.39	10.4	35.4	5.51	3.17	13.2	53.3
	30	2.40	2.40	5.7	12.6	3.32	3.32	7.9	22.1	4.35	3.63	10.4	35.3	5.51	3.41	13.2	53.1	
	7	24	2.37	2.37	4.9	9.5	3.30	2.36	6.8	16.8	4.33	2.15	8.9	26.8	5.49	1.93	11.3	40.4
		25	2.36	2.36	4.8	9.5	3.29	2.60	6.7	16.7	4.32	2.39	8.9	26.7	5.48	2.17	11.2	40.3
		26	2.36	2.36	4.8	9.4	3.28	2.85	6.7	16.6	4.31	2.63	8.8	26.6	5.47	2.42	11.2	40.2
		27	2.35	2.35	4.8	9.4	3.27	3.09	6.7	16.6	4.30	2.87	8.8	26.5	5.46	2.66	11.2	40.0
		28	2.34	2.34	4.8	9.3	3.26	3.26	6.7	16.5	4.30	3.12	8.8	26.4	5.45	2.90	11.2	39.9
		29	2.33	2.33	4.8	9.3	3.26	3.26	6.7	16.4	4.29	3.36	8.8	26.4	5.44	3.15	11.2	39.8
	30	2.33	2.33	4.8	9.2	3.25	3.25	6.7	16.3	4.28	3.60	8.8	26.3	5.43	3.39	11.1	39.7	
	8	24	2.30	2.30	4.1	7.2	3.22	2.33	5.8	12.8	4.26	2.12	7.6	20.7	5.41	1.90	9.7	31.3
		25	2.29	2.29	4.1	7.2	3.22	2.58	5.8	12.8	4.25	2.36	7.6	20.6	5.40	2.15	9.7	31.2
26		2.29	2.29	4.1	7.2	3.21	2.82	5.8	12.7	4.24	2.60	7.6	20.5	5.39	2.39	9.7	31.1	
27		2.28	2.28	4.1	7.1	3.20	3.06	5.7	12.7	4.23	2.85	7.6	20.5	5.38	2.63	9.7	31.0	
28		2.27	2.27	4.1	7.1	3.19	3.19	5.7	12.6	4.22	3.09	7.6	20.4	5.37	2.88	9.6	30.9	
29		2.27	2.27	4.1	7.0	3.19	3.19	5.7	12.6	4.21	3.33	7.6	20.3	5.36	3.12	9.6	30.8	
30	2.26	2.26	4.1	7.0	3.18	3.18	5.7	12.5	4.21	3.58	7.5	20.2	5.35	3.36	9.6	30.7		

Note

- TC : Total capacity, SHC : Sensible Heat Capacity
- Performances are based on the following conditions :
 - Cooling
 - Condition A : Inlet/Outlet Water Temp. 7°C / 12°C, Indoor Air Temp. 27°CDB / 19°CWB
 - Condition B : Inlet/Outlet Water Temp. 10°C / 15°C, Indoor Air Temp. 27°CDB / 19°CWB
 - Condition C : Inlet/Outlet Water Temp. 7°C / 12°C, Indoor Air Temp. 25°CDB / 17.9°CWB
 - Condition D : Inlet/Outlet Water Temp. 14°C / 18°C, Indoor Air Temp. 26°CDB / 18°CWB
- Above capacity tables shows representative values according to the change in temperature or water flow rate, etc., it may vary depending on the installation conditions and the surrounding environment.

6. Capacity Tables

6.2 Heating Capacity

◆ WF4A018CG0A

Water Temp Difference (°C)	Air Temp (°C DB)	Inlet Water Temp.(°C)														
		40			45			50			55			60		
		TC (kW)	Water Flow Rate (LPM)	Pressure Drop (kPa)	TC (kW)	Water Flow Rate (LPM)	Pressure Drop (kPa)	TC (kW)	Water Flow Rate (LPM)	Pressure Drop (kPa)	TC (kW)	Water Flow Rate (LPM)	Pressure Drop (kPa)	TC (kW)	Water Flow Rate (LPM)	Pressure Drop (kPa)
4	16	2.13	7.6	41.9	2.59	9.3	58.7	3.04	10.9	77.9	-	-	-	-	-	-
	18	1.94	7.0	35.9	2.40	8.6	51.7	2.86	10.3	70.0	-	-	-	-	-	-
	20	1.76	6.3	30.3	2.22	8.0	45.1	2.68	9.6	62.4	-	-	-	-	-	-
	22	1.58	5.7	25.1	2.04	7.3	38.9	2.49	8.9	55.2	2.95	10.6	73.9	-	-	-
5	24	1.39	5.0	20.3	1.85	6.6	33.1	2.31	8.3	48.4	2.77	9.9	66.1	-	-	-
	16	2.11	6.1	28.2	2.57	7.4	39.5	3.03	8.7	52.4	3.48	10.0	66.9	-	-	-
	18	1.93	5.5	24.1	2.38	6.8	34.8	2.84	8.2	47.0	3.30	9.5	60.9	3.76	10.8	76.3
	20	1.74	5.0	20.3	2.20	6.3	30.3	2.66	7.6	41.9	3.12	8.9	55.2	3.58	10.3	70.0
6	22	1.56	4.5	16.8	2.02	5.8	26.1	2.48	7.1	37.1	2.93	8.4	49.7	3.39	9.7	63.9
	24	1.38	3.9	13.6	1.83	5.3	22.2	2.29	6.6	32.5	2.75	7.9	44.5	3.21	9.2	58.0
	16	2.09	5.0	20.3	2.55	6.1	28.5	3.01	7.2	37.9	3.47	8.3	48.4	3.92	9.4	59.9
	18	1.91	4.6	17.4	2.37	5.7	25.1	2.82	6.8	34.0	3.28	7.9	44.0	3.74	8.9	55.2
7	20	1.72	4.1	14.7	2.18	5.2	21.9	2.64	6.3	30.3	3.10	7.4	39.9	3.56	8.5	50.6
	22	1.54	3.7	12.1	2.00	4.8	18.8	2.46	5.9	26.8	2.92	7.0	35.9	3.37	8.1	46.2
	24	1.36	3.2	9.8	1.82	4.3	16.0	2.27	5.4	23.5	2.73	6.5	32.1	3.19	7.6	41.9
	16	2.07	4.2	15.4	2.53	5.2	21.6	2.99	6.1	28.8	3.45	7.1	36.7	3.91	8.0	45.6
8	18	1.89	3.9	13.2	2.35	4.8	19.0	2.81	5.8	25.8	3.26	6.7	33.5	3.72	7.6	41.9
	20	1.71	3.5	11.1	2.16	4.4	16.6	2.62	5.4	23.0	3.08	6.3	30.3	3.54	7.3	38.4
	22	1.52	3.1	9.1	1.98	4.1	14.3	2.44	5.0	20.3	2.90	5.9	27.3	3.36	6.9	35.1
	24	1.34	2.7	7.2	1.80	3.7	12.1	2.26	4.6	17.8	2.71	5.6	24.4	3.17	6.5	31.9
9	16	2.05	3.7	12.1	2.51	4.5	17.0	2.97	5.3	22.7	3.43	6.2	29.0	3.89	7.0	35.9
	18	1.87	3.4	10.3	2.33	4.2	15.0	2.79	5.0	20.3	3.25	5.8	26.4	3.70	6.6	33.1
	20	1.69	3.0	8.7	2.15	3.8	13.0	2.60	4.7	18.1	3.06	5.5	23.9	3.52	6.3	30.3
	22	1.50	2.7	6.9	1.96	3.5	11.2	2.42	4.3	16.0	2.88	5.2	21.5	3.34	6.0	27.6
24	1.32	2.4	4.8	1.78	3.2	9.5	2.24	4.0	14.0	2.70	4.8	19.2	3.15	5.7	25.1	

Note

- TC : Total capacity
- Performances are based on the following conditions :
 - Heating
 - Condition A : Inlet/Outlet Water Temp. 45°C / 40°C, Indoor Air Temp. 20°CDB / 15°CWB
 - Condition B : Inlet Water Temp. 50°C, Indoor Air Temp. 20°CDB / 15°CWB
- Above capacity tables shows representative values according to the change in temperature or water flow rate, etc., it may vary depending on the installation conditions and the surrounding environment.

◆ WF4A027CG0A

Water Temp Difference (°C)	Air Temp (°C DB)	Inlet Water Temp.(°C)														
		40			45			50			55			60		
		TC (kW)	Water Flow Rate (LPM)	Pressure Drop (kPa)	TC (kW)	Water Flow Rate (LPM)	Pressure Drop (kPa)	TC (kW)	Water Flow Rate (LPM)	Pressure Drop (kPa)	TC (kW)	Water Flow Rate (LPM)	Pressure Drop (kPa)	TC (kW)	Water Flow Rate (LPM)	Pressure Drop (kPa)
4	16	3.00	10.8	56.5	3.64	13.1	79.3	-	-	-	-	-	-	-	-	-
	18	2.74	9.8	48.3	3.38	12.1	69.8	-	-	-	-	-	-	-	-	-
	20	2.48	8.9	40.7	3.13	11.2	60.8	-	-	-	-	-	-	-	-	-
	22	2.22	8.0	33.7	2.87	10.3	52.3	3.51	12.6	74.5	-	-	-	-	-	-
5	24	1.96	7.0	27.2	2.61	9.4	44.4	3.26	11.7	65.2	-	-	-	-	-	-
	16	2.97	8.5	37.8	3.62	10.4	53.1	4.26	12.2	70.7	-	-	-	-	-	-
	18	2.71	7.8	32.3	3.36	9.6	46.7	4.00	11.5	63.4	-	-	-	-	-	-
	20	2.45	7.0	27.2	3.10	8.9	40.7	3.75	10.8	56.5	4.39	12.6	74.5	-	-	-
6	22	2.20	6.3	22.5	2.84	8.2	35.0	3.49	10.0	49.9	4.13	11.9	67.0	-	-	-
	24	1.94	5.6	18.2	2.58	7.4	29.7	3.23	9.3	43.7	3.88	11.1	59.9	4.52	13.0	78.3
	16	2.95	7.0	27.2	3.59	8.6	38.3	4.24	10.1	51.0	4.88	11.7	65.2	-	-	-
	18	2.69	6.4	23.2	3.33	8.0	33.7	3.98	9.5	45.7	4.62	11.1	59.3	5.27	12.6	74.5
7	20	2.43	5.8	19.6	3.07	7.4	29.3	3.72	8.9	40.7	4.37	10.4	53.7	5.01	12.0	68.2
	22	2.17	5.2	16.1	2.82	6.7	25.2	3.46	8.3	35.9	4.11	9.8	48.3	4.75	11.4	62.2
	24	1.91	4.6	13.0	2.56	6.1	21.4	3.20	7.7	31.4	3.85	9.2	43.2	4.50	10.8	56.5
	16	2.92	6.0	20.6	3.57	7.3	29.0	4.21	8.6	38.6	4.86	10.0	49.4	5.50	11.3	61.4
8	18	2.66	5.5	17.6	3.31	6.8	25.5	3.95	8.1	34.6	4.60	9.4	45.0	5.24	10.8	56.5
	20	2.40	4.9	14.8	3.05	6.3	22.2	3.69	7.6	30.8	4.34	8.9	40.7	4.99	10.2	51.7
	22	2.14	4.4	12.2	2.79	5.7	19.0	3.44	7.0	27.2	4.08	8.4	36.6	4.73	9.7	47.2
	24	1.89	3.9	9.8	2.53	5.2	16.1	3.18	6.5	23.8	3.82	7.8	32.7	4.47	9.2	42.8
9	16	2.89	5.2	16.1	3.54	6.4	22.8	4.19	7.5	30.4	4.83	8.7	38.9	5.48	9.8	48.3
	18	2.64	4.7	13.8	3.28	5.9	20.0	3.93	7.0	27.2	4.57	8.2	35.4	5.22	9.4	44.4
	20	2.38	4.3	11.6	3.02	5.4	17.4	3.67	6.6	24.2	4.31	7.7	32.0	4.96	8.9	40.7
	22	2.12	3.8	9.5	2.76	5.0	14.9	3.41	6.1	21.4	4.06	7.3	28.8	4.70	8.4	37.1
24	1.86	3.3	7.6	2.51	4.5	12.6	3.15	5.7	18.7	3.80	6.8	25.7	4.44	8.0	33.7	

Note

- TC : Total capacity
- Performances are based on the following conditions :
 - Heating
 - Condition A : Inlet/Outlet Water Temp. 45°C / 40°C, Indoor Air Temp. 20°CDB / 15°CWB
 - Condition B : Inlet Water Temp. 50°C, Indoor Air Temp. 20°CDB / 15°CWB
- Above capacity tables shows representative values according to the change in temperature or water flow rate, etc., it may vary depending on the installation conditions and the surrounding environment.

6. Capacity Tables

◆ WF4A031CG0A

Water Temp Difference (°C)	Air Temp (°C DB)	Inlet Water Temp.(°C)														
		40			45			50			55			60		
		TC (kW)	Water Flow Rate (LPM)	Pressure Drop (kPa)	TC (kW)	Water Flow Rate (LPM)	Pressure Drop (kPa)	TC (kW)	Water Flow Rate (LPM)	Pressure Drop (kPa)	TC (kW)	Water Flow Rate (LPM)	Pressure Drop (kPa)	TC (kW)	Water Flow Rate (LPM)	Pressure Drop (kPa)
4	16	3.19	11.4	74.7	-	-	-	-	-	-	-	-	-	-	-	-
	18	2.92	10.5	63.9	-	-	-	-	-	-	-	-	-	-	-	-
	20	2.64	9.5	53.8	-	-	-	-	-	-	-	-	-	-	-	-
	22	2.37	8.5	44.5	3.05	11.0	69.2	-	-	-	-	-	-	-	-	-
	24	2.09	7.5	36.0	2.78	10.0	58.7	-	-	-	-	-	-	-	-	-
5	16	3.16	9.1	50.0	3.85	11.1	70.3	-	-	-	-	-	-	-	-	-
	18	2.89	8.3	42.7	3.58	10.3	61.8	-	-	-	-	-	-	-	-	-
	20	2.61	7.5	36.0	3.30	9.5	53.8	3.99	11.4	74.7	-	-	-	-	-	-
	22	2.34	6.7	29.7	3.03	8.7	46.3	3.71	10.7	66.0	-	-	-	-	-	-
	24	2.06	5.9	24.0	2.75	7.9	39.3	3.44	9.9	57.7	4.13	11.8	79.2	-	-	-
6	16	3.14	7.5	36.0	3.82	9.1	50.6	4.51	10.8	67.4	-	-	-	-	-	-
	18	2.86	6.8	30.7	3.55	8.5	44.5	4.24	10.1	60.4	4.92	11.8	78.5	-	-	-
	20	2.59	6.2	25.8	3.27	7.8	38.7	3.96	9.5	53.8	4.65	11.1	71.0	-	-	-
	22	2.31	5.5	21.3	3.00	7.2	33.3	3.69	8.8	47.5	4.37	10.5	63.9	-	-	-
	24	2.04	4.9	17.2	2.72	6.5	28.2	3.41	8.2	41.6	4.10	9.8	57.1	4.79	11.4	74.7
7	16	3.11	6.4	27.2	3.80	7.8	38.3	4.48	9.2	51.1	5.17	10.6	65.4	-	-	-
	18	2.83	5.8	23.2	3.52	7.2	33.7	4.21	8.6	45.8	4.90	10.0	59.5	5.58	11.4	74.7
	20	2.56	5.2	19.5	3.25	6.7	29.3	3.93	8.1	40.7	4.62	9.5	53.8	5.31	10.9	68.4
	22	2.28	4.7	16.1	2.97	6.1	25.1	3.66	7.5	36.0	4.35	8.9	48.4	5.03	10.3	62.4
	24	2.01	4.1	12.9	2.70	5.5	21.3	3.38	6.9	31.4	4.07	8.3	43.2	4.76	9.8	56.6
8	16	3.08	5.5	21.3	3.77	6.8	30.1	4.46	8.0	40.1	5.14	9.2	51.4	5.83	10.5	63.9
	18	2.81	5.0	18.2	3.49	6.3	26.4	4.18	7.5	36.0	4.87	8.7	46.7	5.56	10.0	58.7
	20	2.53	4.5	15.2	3.22	5.8	23.0	3.91	7.0	32.0	4.59	8.2	42.3	5.28	9.5	53.8
	22	2.26	4.0	12.5	2.94	5.3	19.7	3.63	6.5	28.2	4.32	7.7	38.0	5.01	9.0	49.0
	24	1.98	3.6	10.1	2.67	4.8	16.7	3.36	6.0	24.7	4.04	7.3	33.9	4.73	8.5	44.5

Note

- TC : Total capacity
- Performances are based on the following conditions :
 - Heating
 - Condition A : Inlet/Outlet Water Temp. 45°C / 40°C, Indoor Air Temp. 20°CDB / 15°CWB
 - Condition B : Inlet Water Temp. 50°C, Indoor Air Temp. 20°CDB / 15°CWB
- Above capacity tables shows representative values according to the change in temperature or water flow rate, etc., it may vary depending on the installation conditions and the surrounding environment.

◆ WF4A041CG0A

Water Temp Difference (°C)	Air Temp (°C DB)	Inlet Water Temp.(°C)														
		40			45			50			55			60		
		TC (kW)	Water Flow Rate (LPM)	Pressure Drop (kPa)	TC (kW)	Water Flow Rate (LPM)	Pressure Drop (kPa)	TC (kW)	Water Flow Rate (LPM)	Pressure Drop (kPa)	TC (kW)	Water Flow Rate (LPM)	Pressure Drop (kPa)	TC (kW)	Water Flow Rate (LPM)	Pressure Drop (kPa)
4	16	4.35	15.6	78.6	-	-	-	-	-	-	-	-	-	-	-	-
	18	3.98	14.3	67.2	-	-	-	-	-	-	-	-	-	-	-	-
	20	3.60	12.9	56.5	4.54	16.3	84.6	-	-	-	-	-	-	-	-	-
	22	3.23	11.6	46.7	4.16	14.9	72.8	-	-	-	-	-	-	-	-	-
	24	2.85	10.2	37.6	3.79	13.6	61.7	-	-	-	-	-	-	-	-	-
5	16	4.31	12.4	52.5	5.25	15.1	73.9	-	-	-	-	-	-	-	-	-
	18	3.94	11.3	44.8	4.88	14.0	65.0	-	-	-	-	-	-	-	-	-
	20	3.56	10.2	37.6	4.50	12.9	56.5	5.44	15.6	78.6	-	-	-	-	-	-
	22	3.19	9.2	31.1	4.13	11.8	48.6	5.06	14.5	69.4	-	-	-	-	-	-
	24	2.81	8.1	25.0	3.75	10.8	41.1	4.69	13.5	60.7	5.63	16.1	83.4	-	-	-
6	16	4.28	10.2	37.6	5.21	12.5	53.1	6.15	14.7	70.9	-	-	-	-	-	-
	18	3.90	9.3	32.1	4.84	11.6	46.7	5.78	13.8	63.5	6.71	16.1	82.6	-	-	-
	20	3.53	8.4	27.0	4.46	10.7	40.6	5.40	12.9	56.5	6.34	15.2	74.7	-	-	-
	22	3.15	7.5	22.2	4.09	9.8	34.8	5.03	12.0	49.8	5.96	14.3	67.2	-	-	-
	24	2.78	6.6	17.9	3.71	8.9	29.5	4.65	11.1	43.6	5.59	13.4	60.0	6.53	15.6	78.6
7	16	4.24	8.7	28.4	5.18	10.6	40.1	6.11	12.5	53.6	7.05	14.5	68.7	-	-	-
	18	3.86	7.9	24.2	4.80	9.8	35.2	5.74	11.8	48.0	6.68	13.7	62.5	7.61	15.6	78.6
	20	3.49	7.2	20.3	4.43	9.1	30.6	5.36	11.0	42.7	6.30	12.9	56.5	7.24	14.8	72.0
	22	3.11	6.4	16.7	4.05	8.3	26.3	4.99	10.2	37.6	5.93	12.1	50.8	6.86	14.1	65.6
	24	2.74	5.6	13.4	3.68	7.5	22.2	4.61	9.5	32.9	5.55	11.4	45.3	6.49	13.3	59.5
8	16	4.20	7.5	22.2	5.14	9.2	31.4	6.08	10.9	42.0	7.01	12.6	54.0	7.95	14.3	67.2
	18	3.83	6.9	18.9	4.76	8.5	27.6	5.70	10.2	37.6	6.64	11.9	49.0	7.58	13.6	61.7
	20	3.45	6.2	15.8	4.39	7.9	24.0	5.33	9.6	33.5	6.26	11.2	44.3	7.20	12.9	56.5
	22	3.08	5.5	13.0	4.01	7.2	20.5	4.95	8.9	29.5	5.89	10.6	39.8	6.83	12.2	51.5
	24	2.70	4.8	10.4	3.64	6.5	17.4	4.58	8.2	25.7	5.51	9.9	35.5	6.45	11.6	46.7

Note

- TC : Total capacity
- Performances are based on the following conditions :
 - Heating
 - Condition A : Inlet/Outlet Water Temp. 45°C / 40°C, Indoor Air Temp. 20°CDB / 15°CWB
 - Condition B : Inlet Water Temp. 50°C, Indoor Air Temp. 20°CDB / 15°CWB
- Above capacity tables shows representative values according to the change in temperature or water flow rate, etc., it may vary depending on the installation conditions and the surrounding environment.

7. Air Velocity and Temperature Distribution(Reference Data)

◆ WF4A018CG0A

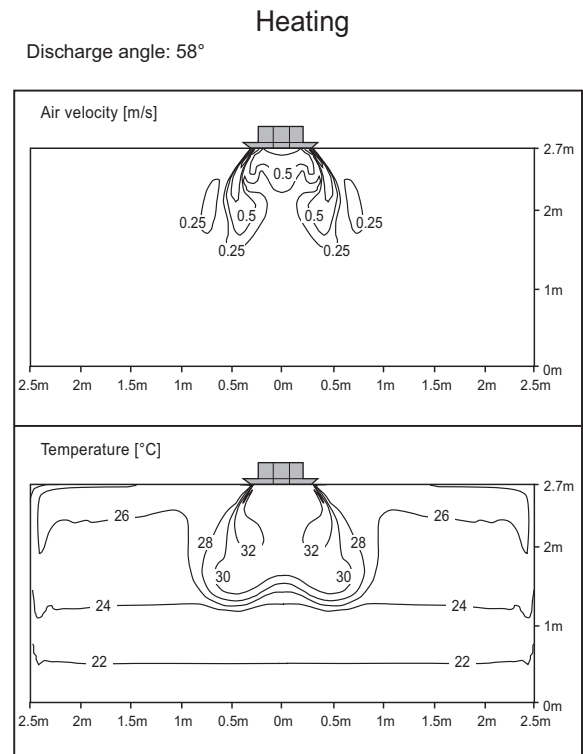
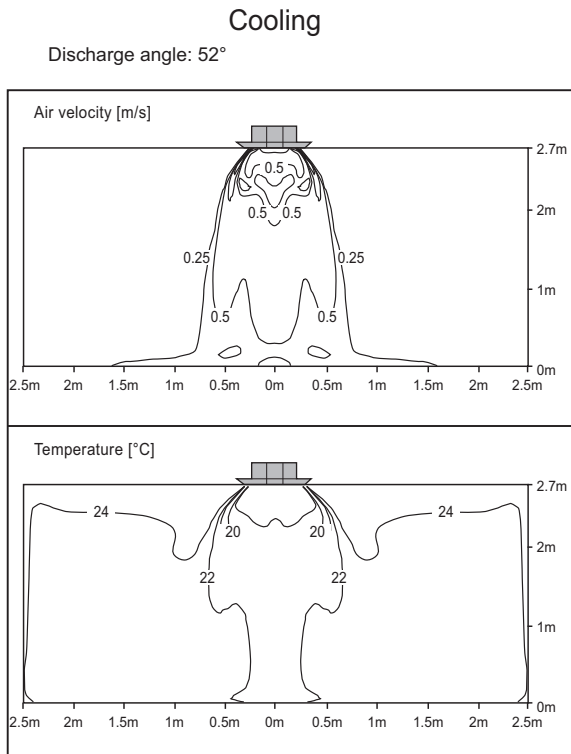

◆ WF4A027CG0A

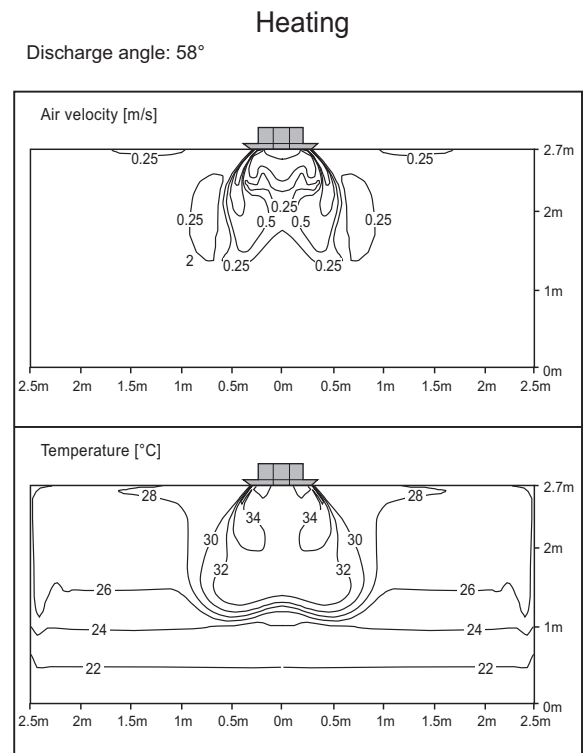
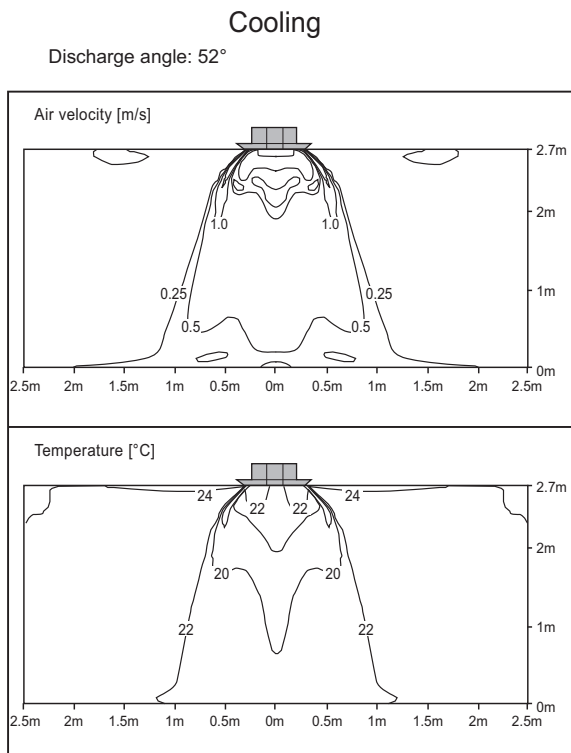

Note

- These figures are accordance with normal certain condition and environment. (Airflow step is 'High', Air discharge angle is fixed as indicated angle.)
- Indoor airflow distribution under actual installation or operating conditions depends on ambient temperature, ceiling height, product installation direction / location, indoor / Heating load, and other obstacles, etc.

7. Air Velocity and Temperature Distribution(Reference Data)

◆ WF4A032CG0A

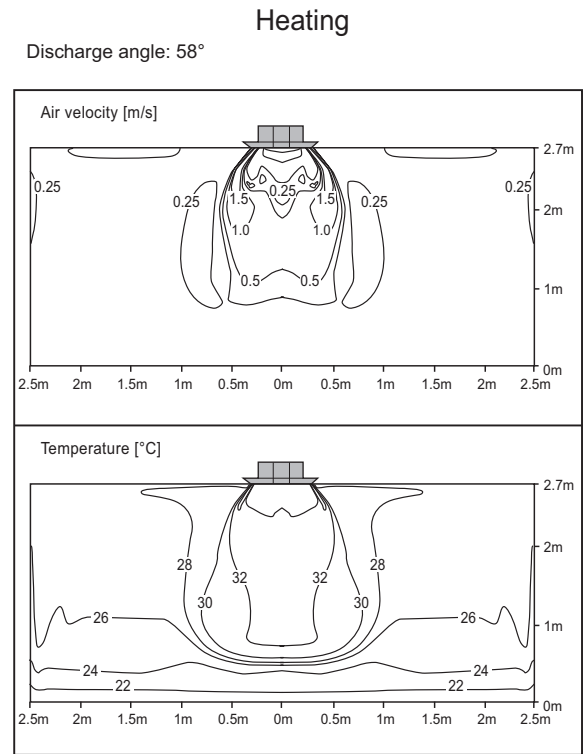
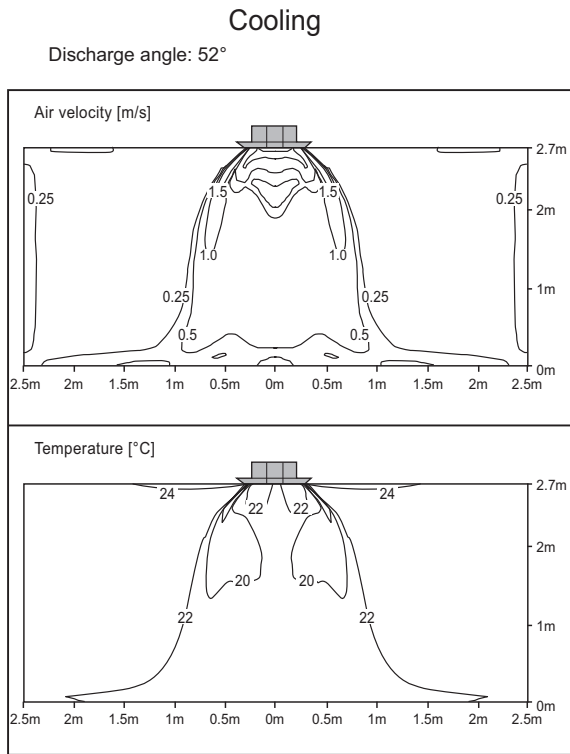

◆ WF4A041CG0A

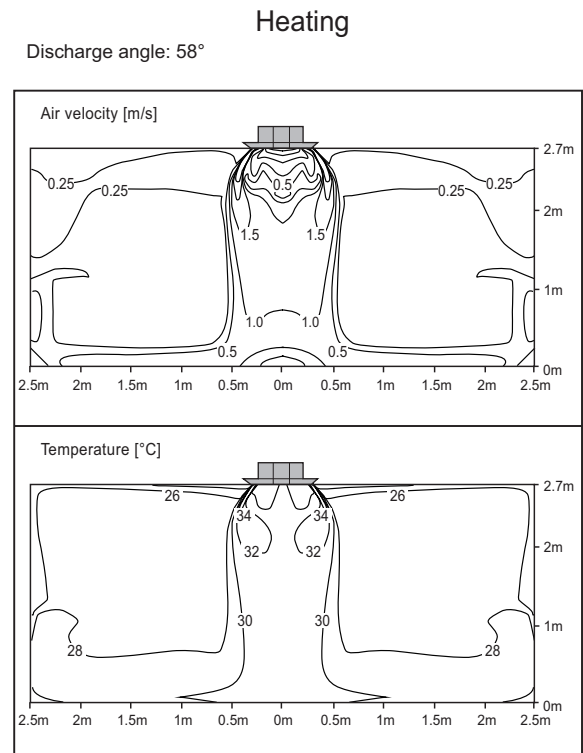
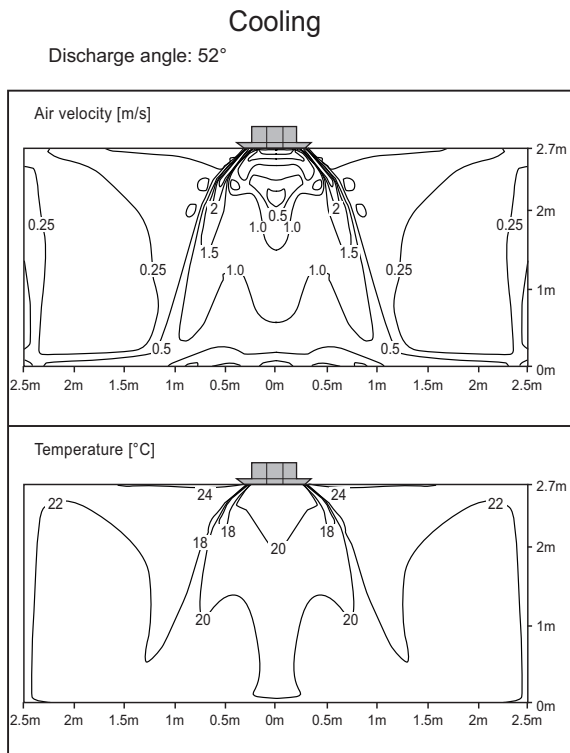

Note

- These figures are accordance with normal certain condition and environment. (Airflow step is 'High', Air discharge angle is fixed as indicated angle.)
- Indoor airflow distribution under actual installation or operating conditions depends on ambient temperature, ceiling height, product installation direction / location, indoor / Heating load, and other obstacles, etc.

8. Electric Characteristics

Unit					Power Supply	IFM		PI	
Model	Type	Hz	Volts	Voltage Range	MCA	kW	FLA	cooling	Heating
WF4A018CG0A	TR	50	220-240	Max. : 264 Min. : 198	0.46	0.030	0.37	12	12
WF4A027CG0A	TR				0.48	0.030	0.38	15	15
WF4A032CG0A	TR				0.50	0.030	0.40	20	20
WF4A041CG0A	TQ				0.53	0.043	0.42	43	43
WF4A018CG0A	TR	60	220	Max. : 242 Min. : 198	0.46	0.030	0.37	12	12
WF4A027CG0A	TR				0.48	0.030	0.38	15	15
WF4A032CG0A	TR				0.50	0.030	0.40	20	20
WF4A041CG0A	TQ				0.53	0.043	0.42	43	43
Symbols MCA : Minimum Circuit Amperes (A) kW : Fan Motor Rated Output (kW) FLA : Full Load Amperes (A) IFM : Indoor Fan Motor PI : Maximum Power Input (W)					Note 1. Voltage range Units are suitable for use on electrical systems where voltage supplied to unit terminals is not below or above the listed range limits. 2. Maximum allowable voltage unbalance between phases is 2%. 3. MCA/MFA $MCA = 1.25 \times FLA$ $MFA = 1.1 \times MCA, MFA \leq 4 \times FLA$ (If MFA is smaller than minimum standard value, Use minimum standard value in region for selecting circuit breaker.) 4. Select wire size based on the MCA 5. Instead of fuse, use Circuit Breaker.				

9. Sound Levels

9.1 Sound Pressure Levels

Overall

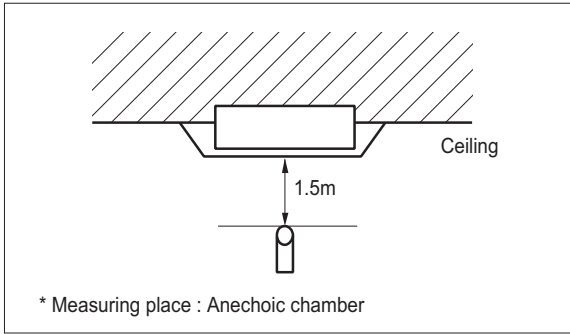

Note

1. Sound measured at some distance away from the center of the unit.
2. Data is valid at free field condition.
3. Reference acoustic pressure 0dB = 20μPa.
4. Data is valid at nominal operation condition.
Refer to the Model Specifications for nominal conditions(Power source and Ambient temperature, etc)
5. Sound levels can be increased in accordance with installation and operating conditions. (Static pressure mode, used air guide, Room target temperature setting, etc)
6. Sound level will vary depending on a range of factors such as the construction(acoustic absorption coefficient) of particular room in which the equipment is installed.
7. Sound pressure level is measured on the rated condition in the anechoic rooms by ISO 3745 standard.
Therefore, these values can be increased owing to ambient conditions during operation.

Model	Sound Pressure Levels [dB(A)]		
	H	M	L
WF4A018CG0A	35	34	33
WF4A027CG0A	38	37	35
WF4A032CG0A	43	40	38
WF4A041CG0A	48	43	38

WF4A018CG0A

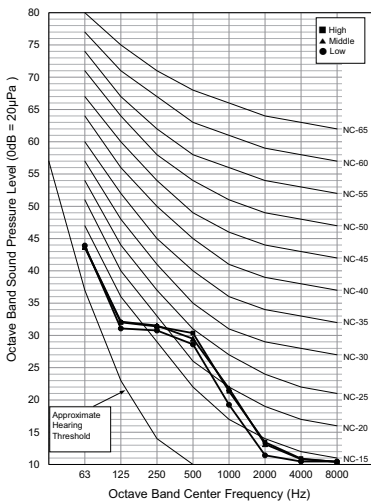

WF4A027CG0A

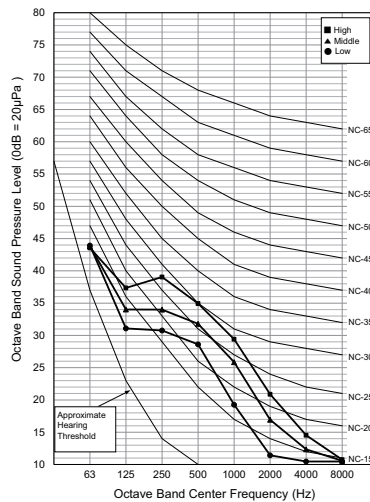

WF4A032CG0A

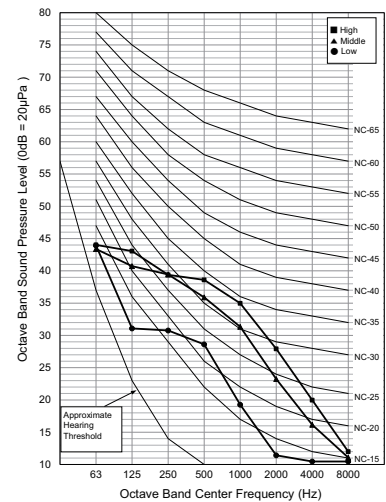

9. Sound Levels

WF4A041CG0A

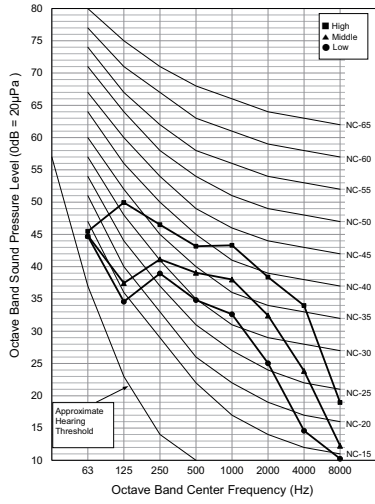

9. Sound Levels

9.2 Sound Power Levels

Note

- Data is valid at diffuse field condition
- Data is valid at nominal operating condition
- Sound level can be increased in static pressure mode or used air guide.
- Sound level will vary depending on a range of factors such as the construction (acoustic absorption coefficient) of particular room in which the equipment is installed.
- Reference acoustic intensity 0dB = $10E-6\mu W/m^2$
- Sound power level is measured on the rated condition in the semi-anechoic rooms by ISO 9614 standard. Therefore, these values can be increased owing to ambient conditions during operation.

Model	Sound Power Levels [dB(A)]		
	H	M	L
WF4A018CG0A	40	39	38
WF4A027CG0A	44	42	40
WF4A032CG0A	50	46	44
WF4A041CG0A	56	50	45

WF4A018CG0A

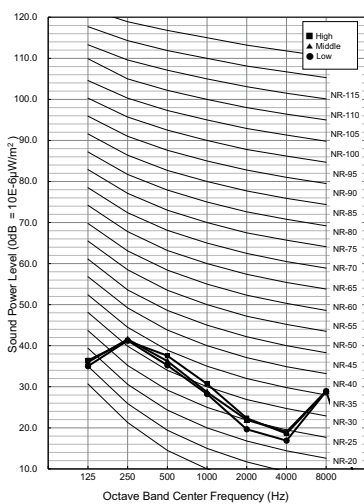

WF4A027CG0A

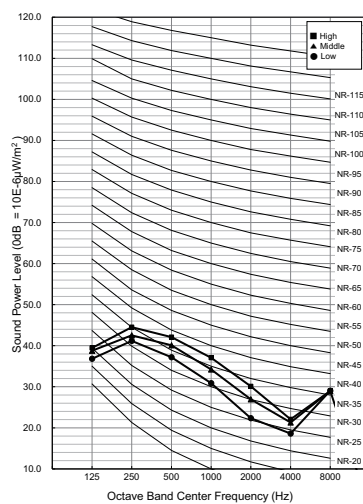

WF4A032CG0A

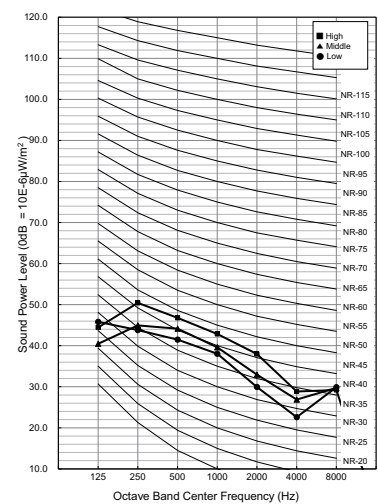

9. Sound Levels

WF4A041CG0A

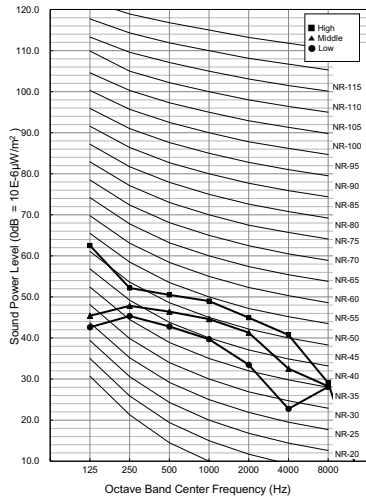

FCU

Ceiling Mounted Cassette (Dual Vane 4-Way)

- 1.List of Functions**
- 2.Specifications**
- 3.Dimensions**
- 4.Piping Diagrams**
- 5.Wiring Diagrams**
- 6.Capacity Tables**
- 7.Air Velocity and Temperature Distribution**
- 8.Electric Characteristics**
- 9.Sound Levels**

1. List of Functions

List of Functions

Category	Function	WF4A060CG0B, WF4A072CG0B, WF4A090CG0B WF4A105CG0B, WF4A130CG0B
Air Flow	Air Supply Outlet	4
	Airflow Direction Control (left & right)	X
	Airflow Direction Control (up & down)	Auto
	Auto Swing (left & right)	X
	Auto Swing (up & down)	O
	Airflow Steps (fan/cool/heat)	4 / 5 / 5
	Fan Speed Auto*	Advanced
	Power Cool/Heat	O / O
	Swirl Wind*	O
	Refresh Mode**	O
	Smart Mode**	O
	Indirect Wind*	O
	Direct Wind*	O
	Dry Operation	O
Air Purification	Pre-Filter	O
	Air Purify	Accessory
	Ionizer	Accessory
	UVnano	X
Reliability	Hot Start	X
	Self Diagnosis	O
Convenience	Filter Check Alarm	O
	Filter Auto Check	X
	Auto Mode	X
	Auto Dry Operation	X
	Auto Restart	O
	Child Lock*	O
	Forced Operation	X
	Group Control*	O
	Sleep Timer**	O
	Turn On/Off Reservation**	O
	Schedule*	O
	Two Thermistor Control*	O
	Time Limit Control (Energy saving)***	O
	Temperature Setback Timer (Energy saving)***	O
External On/Off	O	
Installation	Drain Pump	O
	E.S.P. Setting*	X
	Auto E.S.P. Setting*	X
	High Ceiling Operation*	O
	Duty Rotation / Back up Operation***	X
Water Product functions	Cold And Hot Water Valve Control (ON/OFF, AC 220 V)	O
	Cold And Hot Water Valve Control (Proportional Control, DC 0~10 V)	O
	Freeze Protection Control	O

Note

- O : Applied, X : Not Applied, - : Unconfirmed or irrelevant
Embedded : A kit is provided by default for using this function when the product is manufactured.
Accessory : Ordered and purchased separately the accessory package referring to the model name provided and install at field. Accessory line-ups varies by region, so check your local catalogue or local sales material.
- Some functions can be limited by remote controller.
- In case of cassette type indoor units, Air Purification Kit and Auto Elevation Grille functions are not applicable at the same time.
- 'Auto Mode' varies depending on the outdoor unit type.
- Auto Change Over(Heat Recovery Outdoor Unit)
- Auto Mode Select(Heat Pump Outdoor Unit)
- Auto Intensity Control(Cooling Only Outdoor Unit)
- * : These functions need to connect the wired remote controller.
- ** : These functions need to connect to the Standard II / III wired remote controller.
- *** : These functions need to connect to the Standard III wired remote controller.

1. List of Functions

Category	Function	WF4A060CG0B, WF4A072CG0B, WF4A090CG0B WF4A105CG0B, WF4A130CG0B
Special Functions	Wi-Fi Control	Accessory
	Comfort Cooling (Humidity Control)	X
	Auto Elevation Grille	X
	Human Detection Function***	Accessory
	Floor Detection Function***	Accessory

Note

1. O : Applied, X : Not Applied, - : Unconfirmed or irrelevant
 Embedded : A kit is provided by default for using this function when the product is manufactured.
 Accessory : Ordered and purchased separately the accessory package referring to the model name provided and install at field. Accessory line-ups varies by region, so check your local catalogue or local sales material.
2. Some functions can be limited by remote controller.
3. In case of cassette type indoor units, Air Purification Kit and Auto Elevation Grille functions are not applicable at the same time.
4. 'Auto Mode' varies depending on the outdoor unit type.
 - Auto Change Over(Heat Recovery Outdoor Unit)
 - Auto Mode Select(Heat Pump Outdoor Unit)
 - Auto Intensity Control(Cooling Only Outdoor Unit)
5. * : These functions need to connect the wired remote controller.
6. ** : These functions need to connect to the Standard II / III wired remote controller.
7. *** : These functions need to connect to the Standard III wired remote controller.

1. List of Functions

■ Accessory Compatibility List

Category	Accessory Name	Model Name	Description	WF4A060CG0B WF4A072CG0B WF4A090CG0B WF4A105CG0B WF4A130CG0B
Remote Controller	Wired - Premium	PREMTA000	-	O
		PREMTA000A	-	O
		PREMTA000B	-	O
	Wired - RS3 (Standard III)	PREMTB100	White	O
		PREMTBB10	Black	O
	Wired - RS2 (Standard II)	PREMTB001	White	X
		PREMTBB01	Black	X
	Wired - Simple	PQRCVCL0QW	White	X
		PQRCVCL0Q	Black	X
	Wired - Simple for Hotel	PQRCHCA0QW	White	X
		PQRCHCA0Q	Black	X
	Wireless	PQWRCQ0FDB	For Cooling only	O
PQWRHQ0FDB		For Heat pump	O	
PWLSSB21C		For Cooling only	O	
PWLSSB21H		For Heat pump	O	
Dry Contact	Simple	PDRYCB000	1 input port, AC 220 - 240V	O
		PDRYCB100	1 input port, AC 24V	O
	Communication	PDRYCB400	2 input port	O
		PDRYCB300	8 input port, For 3rd party Thermostat	O
		PDRYCB320	8 input port, For 3rd Party Thermostat (Analog Input)	O
	PDRYCB500	For 3rd Party Controller (Modbus RTU)	O	
Integration Device	Remote Temperature sensor	PQRSTA0	-	O
	Group Control wire	PZCWRCG3	Cable Assembly for group control (Y-type cable : 0.25m, cable : 9.6m)	O
ETC	Extension wire	PZCWRC1	Extension wire for IDU-wired remote controller (9.6m)	O
	2-Remo Control Wire	PZCWRC2	-	O
	Wi-Fi Modem	PWFMDD200	-	O
	Wi-Fi Extension cable	PWYREW000	USB Extension cable : 10 m	O
	Independent Power Module	PRIP0	-	X
	Multi-tenant Power Module	PINPMB001	-	X
	Refrigerant Leakage Detector	PRLDNVS0	For R410A only	X
	Human Detection Sensor	PTVSMA0	For Cassette 4-way	X
		PTVSAA0	For Cassette Dual Vane 4-way	O
	Floor Detection Sensor	PTFSMA0	-	O
	Auto Elevation Grille	PTEGM0	For TP/TN/TM	X
	Air Purification Kit	PTAHTP0	For Cassette 1-way	X
		PTAHMP0	For Cassette 4-way	O
		PTAHYP0	For Cassette Round	X
	EEV Kit	PRGK024A0	For Multi V Indoor Unit	X
	Auxiliary Heater Relay Kit	PRARS1	For Wall Mounted and Art Cool Indoor Units	X
		PRARH1	For Cassette and Duct Indoor Units	X
	Ventilation Kit	PTVK430	For TR/TQ/TP/TN/TM	X
		PTVK410 + PTVK420	For TP/TN/TM	X
	Cassette Cover	PTDCQ	For TR/TQ	X
PTDCM		For TP/TN/TM	X	
PTDCA		For TM-A/TP-B	O	

Note

1. O: Possible, X: Impossible, - : Not applicable, Embedded : Included with product.
2. If there is a difference in development time between the product and the remote controller, some functions cannot be operated.
3. If using Wi-Fi controller, Some advanced functions controlled by remote controller cannot be operated.
4. If you need more detail, please refer to the **BECON** PDB or the manual of product. (<http://partner.lge.com>> Select Your Region : Home> Doc.Library> Product > Control(BECON))

1. List of Functions

■ Panel(Accessory)

Model Name			PT-AAGW0	PT-AFGW0
Description	-		Standard Panel	Premium Panel
Exterior Color	-		White	White
RAL Code	-		RAL 9003	RAL 9003
Dual Vane	-		O	O
Dimensions (W x H x D)	Net	mm	950 x 35 x 950	950 x 35 x 950
	Shipping	mm	1,006 x 102 x 1,006	1,006 x 117 x 1,006
Weight	Net	kg	7.1	7.5
	Shipping	kg	9.3	9.4
Function	PM1.0 Sensor	-	X	O
Accessory	Air Purification Kit	-	X	PTAHMP0
	Floor Detection Sensor*	-	PTFSMA0	PTFSMA0
	Human Detection Sensor*	-	PTVSAA0	PTVSAA0

Note

1. Accessory : Ordered and purchased separately the accessory package referring to the model name provided and install at field.
2. * : This functions need to connect to the RS3 wired remote controller(Standard III).

Model Name			PT-AEGW0
Description	-		Air Purifying & Elevation Panel
Exterior Color	-		White
RAL Code	-		RAL 9003
Dual Vane	-		O
Dimensions (W x H x D)	Net	mm	950 x 35 x 950
	Shipping	mm	1,006 x 117 x 1,006
Weight	Net	kg	10.5
	Shipping	kg	12.4
Function	PM1.0 Sensor	-	O
Accessory	Air Purification Kit	-	O
	Elevation Grille Kit	-	PTVK440
	Floor Detection Sensor*	-	O
	Human Detection Sensor*	-	PTVSAA0

Note

1. Accessory : Ordered and purchased separately the accessory package referring to the model name provided and install at field.
2. * : This functions need to connect to the RS3 wired remote controller(Standard III).

2. Specifications

Type		4 Way Ceiling Mounted Cassette		
Model		Unit	WF4A060CG0B	WF4A072CG0B
Power Supply	Rated Power Supply	V, Φ, Hz	220-230-240, 1, 50	220-230-240, 1, 50
	Limit Range of Voltage	V	198 ~ 264	198 ~ 264
Running Current by Voltage		A	0.31 - 0.30 - 0.29	0.55 - 0.53 - 0.51
Capacity	Cooling	Condition A	6.0 (5,159)	7.2 (6,191)
		Condition B	5.6 (4,815)	6.8 (5,847)
		Condition C	5.8 (4,987)	7.1 (6,105)
		Condition D	3.1 (2,666)	3.8 (3,267)
	Heating	Condition A	6.8 (5,847)	8.1 (6,965)
		Condition B	8.2 (7,051)	10.4 (8,942)
Water Flow Rate	Cooling	Condition A	18.0	21.5
		Condition B	16.5	20.0
		Condition C	17.0	21.0
		Condition D	11.5	14.5
	Heating	Condition A	20.0	24.0
		Condition B	18.0	21.5
Head Loss	Cooling	Condition A	41.1	57.0
		Condition B	37.0	52.4
		Condition C	39.1	57.3
		Condition D	19.7	29.4
	Heating	Condition A	54.2	73.6
		Condition B	41.1	57.0
Power Input	H/M/L	W	31 / 26 / 21	61 / 50 / 42
Running Current	H/M/L	A	0.30 / 0.29 / 0.24	0.53 / 0.50 / 0.42
Fan	Type	-	3D Turbo Fan	3D Turbo Fan
	Air Flow Rate(H/M/L)	m ³ /min	17.0 / 15.0 / 13.0	22.0 / 20.0 / 18.0
Fan Motor	Type	-	BLDC	BLDC
	Drive	-	Direct	Direct
	Output	W × No.	50.25 × 1	50.25 × 1
Dimensions	Net (W x H x D)	mm	840 × 204 × 840	840 × 204 × 840
	Shipping (W x H x D)	mm	922 × 276 × 917	922 × 276 × 917
Weight	Net	kg	20.5	20.5
	Shipping	kg	25.0	25.0
Exterior	Color	-	-	-
	RAL (Classic)	-	-	-
Air Filter	Type	-	Long life	Long life
Temperature Control		-	Microprocessor, Thermostat for cooling and heating	
Sound Absorbing / Thermal Insulation Material		-	Foamed polystyrene	Foamed polystyrene
Protection Device		-	Fuse	Fuse
Water Connecting Pipes	Inlet	-	BSPF G 3/4"(male)	BSPF G 3/4"(male)
	Outlet	-	BSPF G 3/4"(male)	BSPF G 3/4"(male)
Drain Pipe (Natural Drainage)	O.D / I.D	mm	-	-
Drain Pipe (using Drain Pump)	O.D / I.D	mm	Ø 32.0 / 25.0	Ø 32.0 / 25.0
Sound Pressure Level	H/M/L	dB(A)	38.0 / 36.0 / 33.0	45.0 / 43.0 / 41.0
Sound Power Level	H/M/L	dB(A)	46.0 / 44.0 / 42.0	53.0 / 50.0 / 45.0
Connecting Cable	Communication Cable (VCTF-SB)	mm ² ×cores	1.0~1.5 × 2C	1.0~1.5 × 2C

Note

- Due to our policy of innovation some specifications may be changed without notification.
- Wiring cable size must comply with the applicable local and national codes. And "Electric characteristics" chapter should be considered for electrical work and design. Especially the power cable and circuit breaker should be selected in accordance with that.
- Sound Level Values are measured at Noise Measuring chamber accordance with standard. Therefore, these values depend on the ambient conditions and values are normally higher in actual operation.
- Performances are based on the following conditions :
 - Cooling
 - Condition A : Inlet/Outlet Water Temp. 7°C / 12°C, Indoor Air Temp. 27°CDB / 19°CWB
 - Condition B : Inlet/Outlet Water Temp. 10°C / 15°C, Indoor Air Temp. 27°CDB / 19°CWB
 - Condition C : Inlet/Outlet Water Temp. 7°C / 12°C, Indoor Air Temp. 25°CDB / 17.9°CWB
 - Condition D : Inlet/Outlet Water Temp. 14°C / 18°C, Indoor Air Temp. 26°CDB / 18°CWB
 - Heating
 - Condition A : Inlet/Outlet Water Temp. 45°C / 40°C, Indoor Air Temp. 20°CDB / 15°CWB
 - Condition B : Inlet Water Temp. 50°C, Indoor Air Temp. 20°CDB / 15°CWB
- Capacity, power consumption, etc. may vary depending on the product installation conditions (temperature, conditions of use).
- Main power line should be shorter than 50m. When installing a power line longer than 50m, contact LG Electronics.

2. Specifications

Type		4 Way Ceiling Mounted Cassette		
Model		Unit	WF4A090CG0B	WF4A105CG0B
Power Supply	Rated Power Supply	V, Φ, Hz	220-230-240, 1, 50	220-230-240, 1, 50
	Limit Range of Voltage	V	198 ~ 264	198 ~ 264
Running Current by Voltage		A	0.38 - 0.36 - 0.35	0.55 - 0.53 - 0.51
Capacity	Cooling	Condition A	9.0 (7,739)	10.5 (9,028)
		Condition B	6.8 (5,847)	8.0 (6,879)
		Condition C	8.1 (6,965)	9.5 (8,169)
		Condition D	4.6 (3,955)	5.3 (4,557)
	Heating	Condition A	8.5 (7,309)	9.2 (7,911)
		Condition B	11.9 (10,232)	13.7 (11,780)
Water Flow Rate	Cooling	Condition A	27.0	30.5
		Condition B	20.0	23.5
		Condition C	24.0	28.0
		Condition D	17.0	19.5
	Heating	Condition A	25.0	27.0
		Condition B	27.0	30.5
Head Loss	Cooling	Condition A	40.7	52.0
		Condition B	22.7	31.0
		Condition C	32.4	44.3
		Condition D	16.6	21.2
	Heating	Condition A	35.0	41.3
		Condition B	40.7	52.0
Power Input	H/M/L	W	39 / 33 / 26	60 / 50 / 40
Running Current	H/M/L	A	0.36 / 0.35 / 0.29	0.53 / 0.50 / 0.41
Fan	Type	-	3D Turbo Fan	3D Turbo Fan
	Air Flow Rate(H/M/L)	m ³ /min	21.0 / 19.0 / 16.0	25.0 / 23.0 / 21.0
Fan Motor	Type	-	BLDC	BLDC
	Drive	-	Direct	Direct
	Output	W x No.	145.68 × 1	145.68 × 1
Dimensions	Net (W x H x D)	mm	840 × 288 × 840	840 × 288 × 840
	Shipping (W x H x D)	mm	922 × 360 × 917	922 × 360 × 917
Weight	Net	kg	25.0	25.0
	Shipping	kg	30.0	30.0
Exterior	Color	-	-	-
	RAL (Classic)	-	-	-
Air Filter	Type	-	Long life	Long life
Temperature Control		-	Microprocessor, Thermostat for cooling and heating	
Sound Absorbing / Thermal Insulation Material		-	Foamed polystyrene	Foamed polystyrene
Protection Device		-	Fuse	Fuse
Water Connecting Pipes	Inlet	-	BSPF G 3/4"(male)	BSPF G 3/4"(male)
	Outlet	-	BSPF G 3/4"(male)	BSPF G 3/4"(male)
Drain Pipe (Natural Drainage)	O.D / I.D	mm	-	-
Drain Pipe (using Drain Pump)	O.D / I.D	mm	Ø 32.0 / 25.0	Ø 32.0 / 25.0
Sound Pressure Level	H/M/L	dB(A)	37.0 / 35.0 / 31.0	42.0 / 40.0 / 37.0
Sound Power Level	H/M/L	dB(A)	53.0 / 50.0 / 45.0	54.0 / 51.0 / 47.0
Connecting Cable	Communication Cable (VCTF-SB)	mm ² ×cores	1.0~1.5 × 2C	1.0~1.5 × 2C

Note

- Due to our policy of innovation some specifications may be changed without notification.
- Wiring cable size must comply with the applicable local and national codes. And "Electric characteristics" chapter should be considered for electrical work and design. Especially the power cable and circuit breaker should be selected in accordance with that.
- Sound Level Values are measured at Noise Measuring chamber accordance with standard. Therefore, these values depend on the ambient conditions and values are normally higher in actual operation.
- Performances are based on the following conditions :
 - Cooling
 - Condition A : Inlet/Outlet Water Temp. 7°C / 12°C, Indoor Air Temp. 27°CDB / 19°CWB
 - Condition B : Inlet/Outlet Water Temp. 10°C / 15°C, Indoor Air Temp. 27°CDB / 19°CWB
 - Condition C : Inlet/Outlet Water Temp. 7°C / 12°C, Indoor Air Temp. 25°CDB / 17.9°CWB
 - Condition D : Inlet/Outlet Water Temp. 14°C / 18°C, Indoor Air Temp. 26°CDB / 18°CWB
 - Heating
 - Condition A : Inlet/Outlet Water Temp. 45°C / 40°C, Indoor Air Temp. 20°CDB / 15°CWB
 - Condition B : Inlet Water Temp. 50°C, Indoor Air Temp. 20°CDB / 15°CWB
- Capacity, power consumption, etc. may vary depending on the product installation conditions (temperature, conditions of use).
- Main power line should be shorter than 50m. When installing a power line longer than 50m, contact LG Electronics.

2. Specifications

Type		4 Way Ceiling Mounted Cassette	
Model		kW	WF4A130CG0B
Power Supply	Rated Power Supply	V, Φ, Hz	220-230-240, 1, 50
	Limit Range of Voltage	V	198 ~ 264
Running Current by Voltage		A	0.96 - 0.92 - 0.88
Capacity	Cooling	Condition A	13.0 (11,178)
		Condition B	8.5 (7,309)
		Condition C	9.8 (8,426)
		Condition D	6.0 (5,159)
	Heating	Condition A	10.7 (9,200)
		Condition B	16.8 (14,445)
Water Flow Rate	Cooling	Condition A	37.0
		Condition B	25.0
		Condition C	29.0
		Condition D	22.0
	Heating	Condition A	31.5
		Condition B	37.0
Head Loss	Cooling	Condition A	77.8
		Condition B	35.3
		Condition C	47.6
		Condition D	27.1
	Heating	Condition A	56.6
		Condition B	77.8
Power Input	H/M/L	W	115 / 94 / 69
Running Current	H/M/L	A	0.92 / 0.87 / 0.66
Fan	Type	-	3D Turbo Fan
	Air Flow Rate(H/M/L)	m ³ /min	33.0 / 30.0 / 27.0
Fan Motor	Type	-	BLDC
	Drive	-	Direct
	Output	W x No.	145.68 × 1
Dimensions	Net (W x H x D)	mm	840 × 288 × 840
	Shipping (W x H x D)	mm	922 × 360 × 917
Weight	Net	kg	25.0
	Shipping	kg	30.0
Exterior	Color	-	-
	RAL (Classic)	-	-
Air Filter	Type	-	Long life
Temperature Control		-	Microprocessor, Thermostat for cooling and heating
Sound Absorbing / Thermal Insulation Material		-	Foamed polystyrene
Protection Divice		-	Fuse
Water Connecting Pipes	Inlet	-	BSPF G 3/4"(male)
	Outlet	-	BSPF G 3/4"(male)
Drain Pipe (Natural Drainage)	O.D / I.D	mm	-
Drain Pipe (using Drain Pump)	O.D / I.D	mm	Ø 32.0 / 25.0
Sound Pressure Level	H/M/L	dB(A)	48.0 / 47.0 / 43.0
Sound Power Level	H/M/L	dB(A)	56.0 / 53.0 / 49.0
Connecting Cable	Communication Cable (VCTF-SB)	mm ² ×cores	1.0~1.5 × 2C

Note

1. Due to our policy of innovation some specifications may be changed without notification.
2. Wiring cable size must comply with the applicable local and national codes. And "Electric characteristics" chapter should be considered for electrical work and design. Especially the power cable and circuit breaker should be selected in accordance with that.
3. Sound Level Values are measured at Noise Measuring chamber accordance with standard. Therefore, these values depend on the ambient conditions and values are normally higher in actual operation.
4. Performances are based on the following conditions :
 - 1) Cooling
 - Condition A : Inlet/Outlet Water Temp. 7°C / 12°C, Indoor Air Temp. 27°CDB / 19°CWB
 - Condition B : Inlet/Outlet Water Temp. 10°C / 15°C, Indoor Air Temp. 27°CDB / 19°CWB
 - Condition C : Inlet/Outlet Water Temp. 7°C / 12°C, Indoor Air Temp. 25°CDB / 17.9°CWB
 - Condition D : Inlet/Outlet Water Temp. 14°C / 18°C, Indoor Air Temp. 26°CDB / 18°CWB
 - 2) Heating
 - Condition A : Inlet/Outlet Water Temp. 45°C / 40°C, Indoor Air Temp. 20°CDB / 15°CWB
 - Condition B : Inlet Water Temp. 50°C, Indoor Air Temp. 20°CDB / 15°CWB
5. Capacity, power consumption, etc. may vary depending on the product installation conditions (temperature, conditions of use).
6. Main power line should be shorter than 50m. When installing a power line longer than 50m, contact LG Electronics.

3. Dimensions

3.1 Dimensional Drawings

■ TP-B Chassis : WF4A060CG0B, WF4A072CG0B

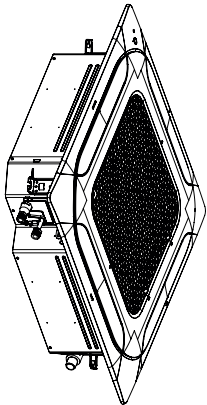

3D VIEW

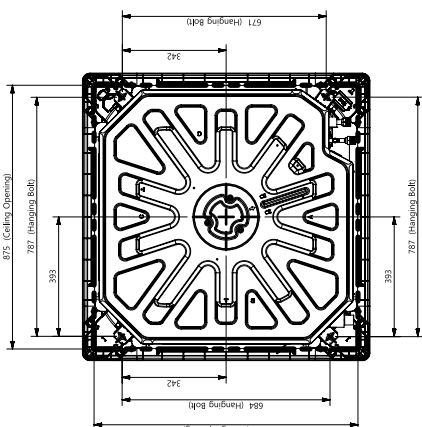

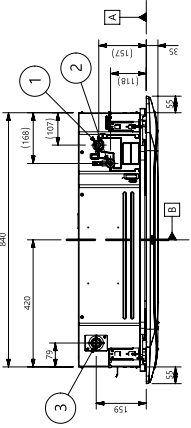

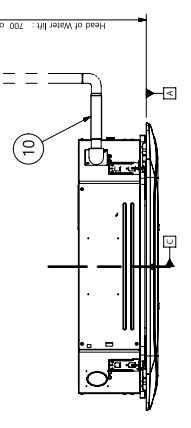

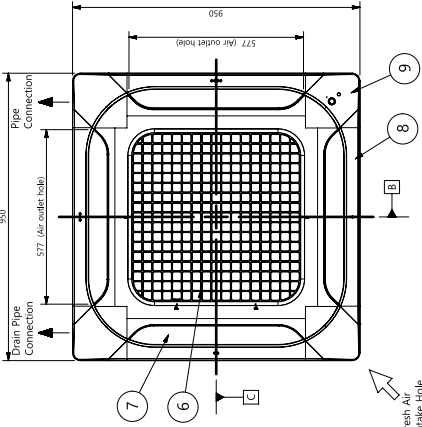

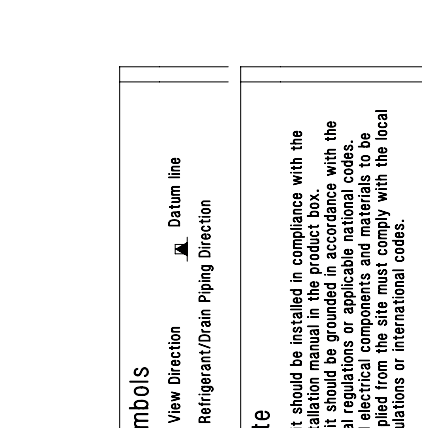

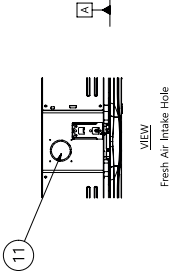

VIEW
Fresh Air Intake Hole

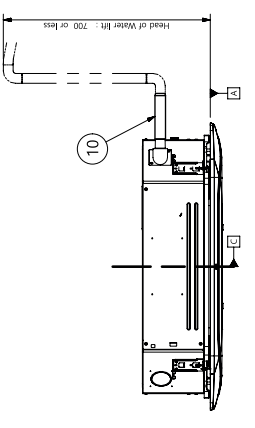

Head of Water lift : 700 or less

Installation position of body

(Keep This distance between the bottom surface of the body and Ceiling Surface)

Installation position of body

(Keep This distance between the bottom surface of the body and Ceiling Surface)

No.	Part Name	Description
11	Fresh Air Intake Hole	Knock-out type
10	Flexible Drain Hose	-
9	Decoration Corner Cover	Supplied with panel
8	Decoration Panel (Accessory)	PF*-WA**W / PT-A****
7	Air Outlet	-
6	Air Inlet	-
5	Wired remote controller wire routing hole	-
4	Power and communication cable routing hole	-
3	Drain Pipe Connection	-
2	Water Outlet Pipe Connection	PF(BSPF G) 3/4", Male
1	Water Inlet Pipe Connection	PF(BSPF G) 3/4", Male

Symbols

- ⇨ View Direction
- Datum line
- Refrigerant/Drain Piping Direction

Note

1. Unit should be installed in compliance with the installation manual in the product box.
2. Unit should be grounded in accordance with the local regulations or applicable national codes.
3. All electrical components and materials to be supplied from the site must comply with the local regulations or international codes.

3. Dimensions

■ **TM-A Chassis : WF4A090CG0B , WF4A105CG0B, WF4A130CG0B**

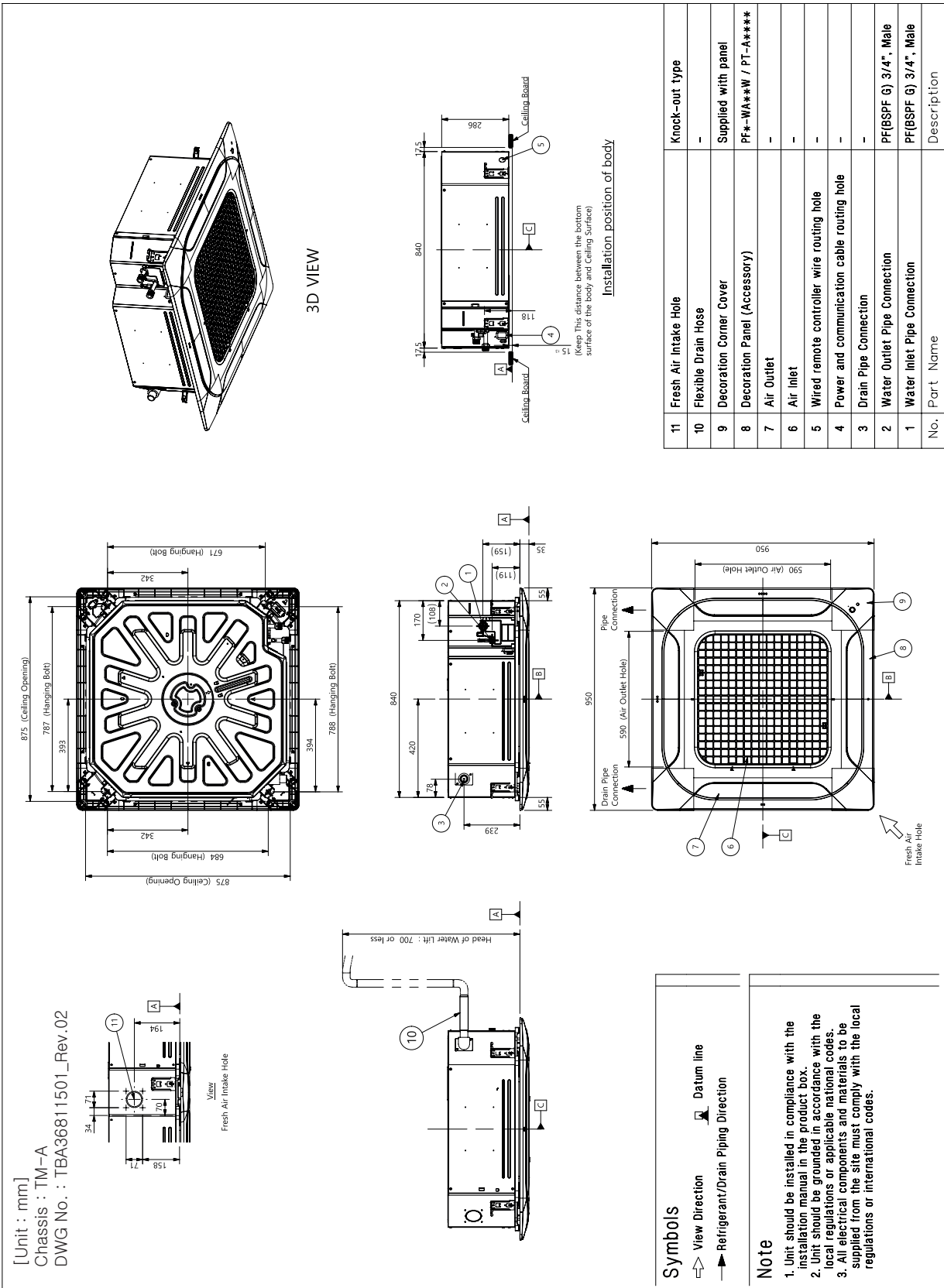

3. Dimensions

3.2 Installation Space

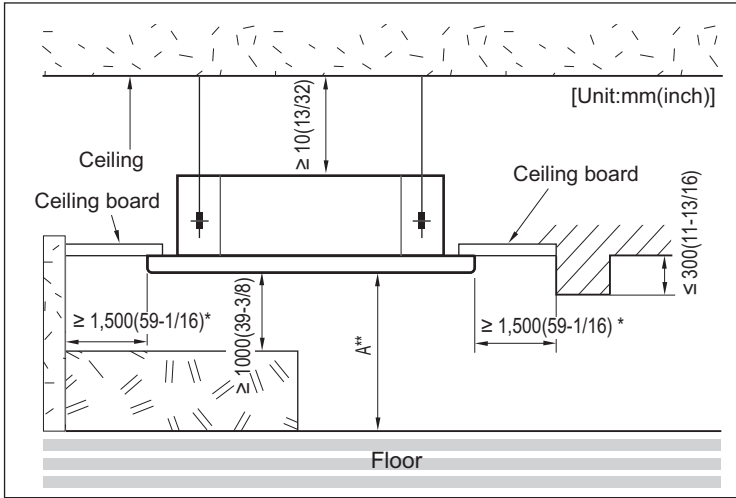

Notes

1. *: Minimum Installation Space to Air flow direction
A separation distance of at least 1,500 mm is required throughout the airflow direction.

2. **: A, Installation Height from the floor

Capacity Class	Installation Height (A)		
	Min.	Standard ***	Max.
< 10 kW	2.0 m (6.56 ft)	2.7 m (8.86 ft)	3.6 m (11.81 ft)
≥ 10 kW	2.5 m (8.20 ft)	3.2 m (10.50 ft)	4.2 m (13.78 ft)

*** : Standard Height (Recommended)

If it exceeds the standard height, set the 'High Ceiling Mode'.
For details about function setting, refer to the installation manual.

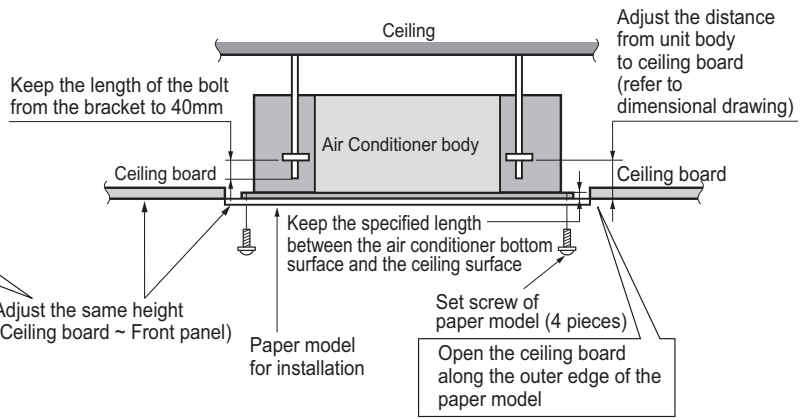
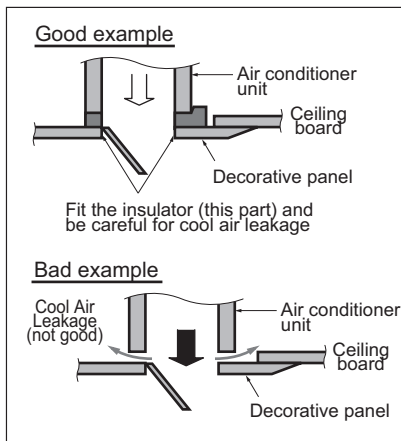

Note

- Places where products are installed should not be any obstacles to the air circulation or installation. Ensure the spaces from the wall, ceiling, or other obstacles.
- According to type of indoor unit, external appearance or installed structure could be different.
- According to product type, model line up, sales region..etc, applicability of each chassis could be different.
- Install certainly the decoration panel. Cool air leakage causes sweating or falling of water-drops.

4. Piping Diagrams

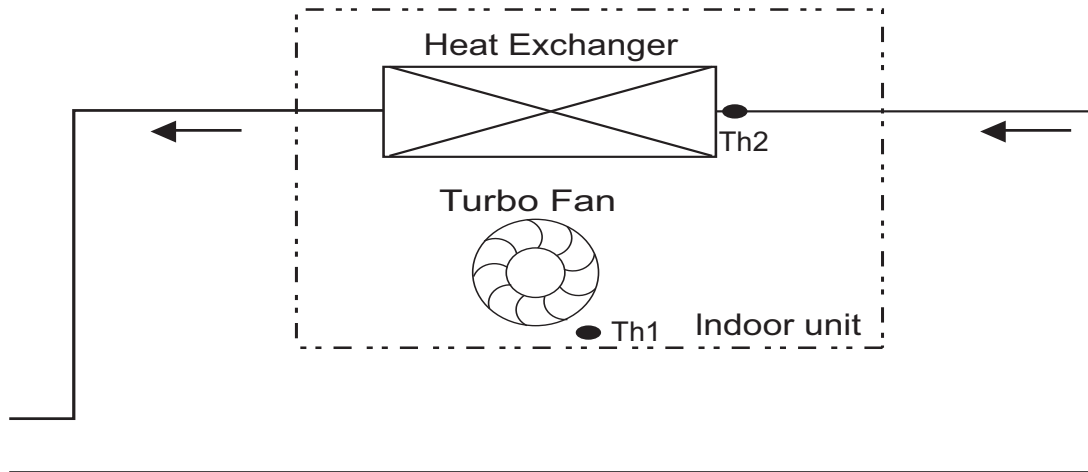

LOC.	Description
Th1	Room thermistor
Th2	Pipe in thermistor

5. Wiring Diagrams

TP-B / TM-A Chassis

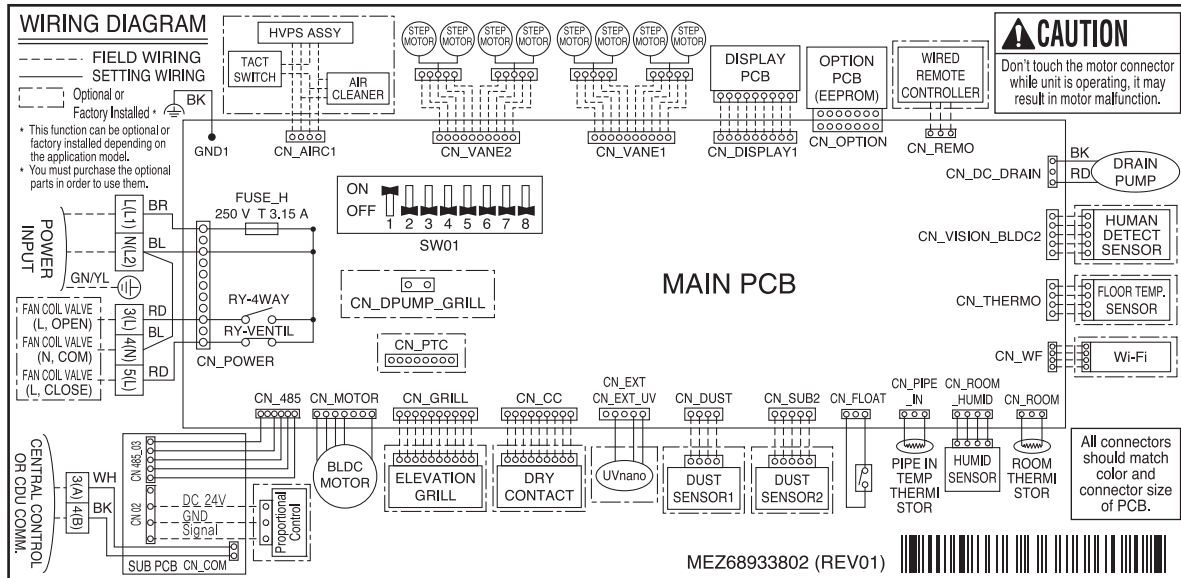

◆ Dip SW Setting Table

No.	Function	Description	Setting		Default (At the time of factory ship-out)	FCU
			OFF	ON		
SW1	Communication mode	Communication / Non communication model selection	Communication	Non communication	ON	Use
SW2	Cooling / heating mode	Cooling / heating mode selection	Cooling/heating	Cooling exclusive	OFF	Use
SW3	Group control	Master / slave selection	Master	Slave	OFF	Use
SW4	Dry contact mode	- Variable : Manual or automatic selection of wired wireless remote control - Automatic	Variable	Automatic	OFF	Use
SW5	Fan continuous operation	For Duct type	Fan continuous operation removal	Fan continuous operation	OFF	N/A
	EXTRA	Cassette type	-	-	OFF	
	Installation type	For Ceiling Suspended type For Round Cassette	Ceiling Exposed	Floor Half Concealed	OFF	
SW6	Heater linkage	-	-	-	OFF	N/A
SW7	Ventilator linkage	Selection of Ventilator linkage	Linkage Removal	Working	OFF	N/A
	Vane selection (Console)	For Console type (Top/Bottom vane)	Top + Bottom Vane	Top Vane Only		
SW8	Region selection	Selection tropical region	General model	Tropical model	OFF	Use
	Communication method	LGAP/Modbus selection	Modbus	LGAP		

Note

- For product type, available Dip Switch No. could be different.
- Dip switch marked 'N/A' should be OFF. Those will be used for other product.

6. Capacity Tables

Inlet Water Temp. (°C)	Water Temp Difference (°C)	Air Temp (°C DB)	Air Temp(17°C WB)				Air Temp(19°C WB)				Air Temp(21°C WB)				Air Temp(23°C WB)			
			TC (kW)	SHC (kW)	Water Flow Rate (LPM)	Pressure Drop (kPa)	TC (kW)	SHC (kW)	Water Flow Rate (LPM)	Pressure Drop (kPa)	TC (kW)	SHC (kW)	Water Flow Rate (LPM)	Pressure Drop (kPa)	TC (kW)	SHC (kW)	Water Flow Rate (LPM)	Pressure Drop (kPa)
9	4	24	3.77	3.77	13.5	26.9	5.13	3.53	18.4	46.2	6.65	3.24	23.9	73.0	8.35	2.94	30.0	109.1
		25	3.76	3.76	13.5	26.8	5.12	3.88	18.4	46.1	6.64	3.58	23.8	72.8	8.34	3.28	29.9	108.8
		26	3.75	3.75	13.5	26.7	5.11	4.23	18.3	45.9	6.63	3.93	23.8	72.5	8.32	3.63	29.9	108.5
		27	3.74	3.74	13.4	26.6	5.10	4.57	18.3	45.7	6.62	4.28	23.7	72.3	8.31	3.98	29.8	108.2
		28	3.73	3.73	13.4	26.4	5.09	4.92	18.3	45.5	6.60	4.62	23.7	72.0	8.30	4.33	29.8	107.9
		29	3.72	3.72	13.3	26.3	5.08	5.08	18.2	45.4	6.59	4.97	23.7	71.8	8.28	4.67	29.7	107.5
	30	3.71	3.71	13.3	26.2	5.07	5.07	18.2	45.2	6.58	5.32	23.6	71.6	8.27	5.02	29.7	107.2	
	5	24	3.67	3.67	10.5	17.4	5.03	3.50	14.4	30.2	6.55	3.20	18.8	47.9	8.24	2.90	23.7	71.9
		25	3.66	3.66	10.5	17.4	5.02	3.84	14.4	30.1	6.54	3.54	18.8	47.8	8.23	3.25	23.6	71.6
		26	3.65	3.65	10.5	17.3	5.01	4.19	14.4	30.0	6.52	3.89	18.7	47.6	8.22	3.59	23.6	71.4
		27	3.64	3.64	10.5	17.2	5.00	4.54	14.3	29.8	6.51	4.24	18.7	47.4	8.20	3.94	23.6	71.2
		28	3.63	3.63	10.4	17.1	4.99	4.88	14.3	29.7	6.50	4.59	18.7	47.3	8.19	4.29	23.5	71.0
		29	3.62	3.62	10.4	17.0	4.98	4.98	14.3	29.6	6.49	4.93	18.6	47.1	8.17	4.64	23.5	70.8
	30	3.61	3.61	10.4	17.0	4.96	4.96	14.3	29.5	6.47	5.28	18.6	47.0	8.16	4.98	23.4	70.6	
	6	24	3.57	3.57	8.5	12.1	4.93	3.46	11.8	21.2	6.44	3.16	15.4	33.8	8.13	2.86	19.5	50.9
		25	3.56	3.56	8.5	12.1	4.92	3.80	11.8	21.1	6.43	3.51	15.4	33.7	8.12	3.21	19.4	50.8
		26	3.55	3.55	8.5	12.0	4.91	4.15	11.7	21.0	6.42	3.85	15.4	33.6	8.11	3.55	19.4	50.6
		27	3.54	3.54	8.5	12.0	4.89	4.50	11.7	21.0	6.41	4.20	15.3	33.5	8.09	3.90	19.4	50.5
		28	3.53	3.53	8.4	11.9	4.88	4.84	11.7	20.9	6.39	4.55	15.3	33.4	8.08	4.25	19.3	50.3
		29	3.52	3.52	8.4	11.8	4.87	4.87	11.7	20.8	6.38	4.89	15.3	33.3	8.06	4.60	19.3	50.2
	30	3.51	3.51	8.4	11.8	4.86	4.86	11.6	20.7	6.37	5.24	15.2	33.2	8.05	4.94	19.3	50.0	
	7	24	3.47	3.47	7.1	8.9	4.83	3.42	9.9	15.6	6.34	3.12	13.0	25.1	8.02	2.82	16.5	37.9
		25	3.46	3.46	7.1	8.8	4.81	3.76	9.9	15.6	6.32	3.47	13.0	25.0	8.01	3.17	16.4	37.8
		26	3.45	3.45	7.1	8.8	4.80	4.11	9.8	15.5	6.31	3.81	12.9	24.9	8.00	3.52	16.4	37.7
		27	3.44	3.44	7.1	8.7	4.79	4.46	9.8	15.5	6.30	4.16	12.9	24.9	7.98	3.86	16.4	37.6
		28	3.43	3.43	7.0	8.7	4.78	4.78	9.8	15.4	6.29	4.51	12.9	24.8	7.97	4.21	16.3	37.5
		29	3.42	3.42	7.0	8.6	4.77	4.77	9.8	15.3	6.27	4.86	12.9	24.7	7.95	4.56	16.3	37.4
	30	3.41	3.41	7.0	8.6	4.76	4.76	9.8	15.3	6.26	5.20	12.8	24.6	7.94	4.91	16.3	37.2	
	8	24	3.37	3.37	6.0	6.7	4.72	3.38	8.5	12.0	6.23	3.08	11.2	19.3	7.91	2.78	14.2	29.3
		25	3.36	3.36	6.0	6.7	4.71	3.73	8.5	11.9	6.22	3.43	11.2	19.3	7.90	3.13	14.2	29.2
26		3.35	3.35	6.0	6.6	4.70	4.07	8.4	11.9	6.20	3.78	11.1	19.2	7.89	3.48	14.2	29.1	
27		3.34	3.34	6.0	6.6	4.69	4.42	8.4	11.8	6.19	4.12	11.1	19.1	7.87	3.82	14.1	29.0	
28		3.33	3.33	6.0	6.6	4.68	4.68	8.4	11.8	6.18	4.47	11.1	19.1	7.86	4.17	14.1	29.0	
29		3.32	3.32	6.0	6.5	4.67	4.67	8.4	11.7	6.17	4.82	11.1	19.0	7.84	4.52	14.1	28.9	
30	3.31	3.31	5.9	6.5	4.66	4.66	8.4	11.7	6.15	5.16	11.0	18.9	7.83	4.87	14.1	28.8		

Note

- TC : Total capacity, SHC : Sensible Heat Capacity
- Performances are based on the following conditions :
 - Cooling
 - Condition A : Inlet/Outlet Water Temp. 7°C / 12°C, Indoor Air Temp. 27°CDB / 19°CWB
 - Condition B : Inlet/Outlet Water Temp. 10°C / 15°C, Indoor Air Temp. 27°CDB / 19°CWB
 - Condition C : Inlet/Outlet Water Temp. 7°C / 12°C, Indoor Air Temp. 25°CDB / 17.9°CWB
 - Condition D : Inlet/Outlet Water Temp. 14°C / 18°C, Indoor Air Temp. 26°CDB / 18°CWB
- Above capacity tables shows representative values according to the change in temperature or water flow rate, etc., it may vary depending on the installation conditions and the surrounding environment.

6. Capacity Tables

Inlet Water Temp. (°C)	Water Temp Difference (°C)	Air Temp (°C DB)	Air Temp(17°C WB)				Air Temp(19°C WB)				Air Temp(21°C WB)				Air Temp(23°C WB)			
			TC (kW)	SHC (kW)	Water Flow Rate (LPM)	Pressure Drop (kPa)	TC (kW)	SHC (kW)	Water Flow Rate (LPM)	Pressure Drop (kPa)	TC (kW)	SHC (kW)	Water Flow Rate (LPM)	Pressure Drop (kPa)	TC (kW)	SHC (kW)	Water Flow Rate (LPM)	Pressure Drop (kPa)
9	4	24	4.51	4.51	16.2	37.2	6.16	4.32	22.1	64.1	7.99	3.93	28.7	101.6	10.04	3.53	36.0	152.4
		25	4.50	4.50	16.2	37.0	6.14	4.76	22.0	63.8	7.98	4.36	28.6	101.2	10.02	3.97	36.0	151.9
		26	4.49	4.49	16.1	36.8	6.13	5.19	22.0	63.6	7.96	4.80	28.6	100.9	10.01	4.40	35.9	151.5
		27	4.48	4.48	16.1	36.6	6.11	5.63	21.9	63.3	7.94	5.23	28.5	100.5	9.99	4.84	35.9	151.0
		28	4.46	4.46	16.0	36.4	6.10	6.10	21.9	63.1	7.93	5.67	28.5	100.2	9.97	5.27	35.8	150.5
		29	4.45	4.45	16.0	36.3	6.09	6.09	21.8	62.8	7.91	6.10	28.4	99.8	9.96	5.71	35.7	150.1
	30	4.44	4.44	15.9	36.1	6.07	6.07	21.8	62.5	7.90	6.54	28.3	99.5	9.94	6.14	35.7	149.6	
	5	24	4.40	4.40	12.6	24.0	6.03	4.28	17.3	41.8	7.86	3.88	22.6	66.6	9.91	3.48	28.5	100.2
		25	4.38	4.38	12.6	23.9	6.02	4.71	17.3	41.6	7.85	4.32	22.5	66.3	9.89	3.92	28.4	99.9
		26	4.37	4.37	12.5	23.8	6.00	5.15	17.2	41.4	7.83	4.75	22.5	66.1	9.87	4.36	28.4	99.6
		27	4.36	4.36	12.5	23.7	5.99	5.58	17.2	41.3	7.82	5.19	22.4	65.9	9.86	4.79	28.3	99.2
		28	4.35	4.35	12.5	23.6	5.98	5.98	17.2	41.1	7.80	5.62	22.4	65.6	9.84	5.23	28.3	98.9
		29	4.33	4.33	12.4	23.4	5.96	5.96	17.1	40.9	7.79	6.06	22.3	65.4	9.82	5.66	28.2	98.6
	30	4.32	4.32	12.4	23.3	5.95	5.95	17.1	40.8	7.77	6.49	22.3	65.2	9.81	6.10	28.2	98.3	
	6	24	4.28	4.28	10.2	16.7	5.91	4.23	14.1	29.3	7.74	3.84	18.5	46.9	9.78	3.44	23.4	70.9
		25	4.26	4.26	10.2	16.6	5.90	4.67	14.1	29.2	7.72	4.27	18.5	46.8	9.76	3.87	23.4	70.7
		26	4.25	4.25	10.2	16.5	5.88	5.10	14.1	29.0	7.70	4.71	18.4	46.6	9.74	4.31	23.3	70.4
		27	4.24	4.24	10.1	16.4	5.87	5.54	14.0	28.9	7.69	5.14	18.4	46.4	9.72	4.74	23.3	70.2
		28	4.23	4.23	10.1	16.3	5.85	5.85	14.0	28.8	7.67	5.58	18.4	46.3	9.71	5.18	23.2	70.0
		29	4.21	4.21	10.1	16.3	5.84	5.84	14.0	28.7	7.66	6.01	18.3	46.1	9.69	5.62	23.2	69.8
	30	4.20	4.20	10.1	16.2	5.83	5.83	13.9	28.6	7.64	6.45	18.3	45.9	9.67	6.05	23.1	69.6	
	7	24	4.16	4.16	8.5	12.2	5.79	4.19	11.9	21.6	7.61	3.79	15.6	34.8	9.64	3.39	19.8	52.7
		25	4.14	4.14	8.5	12.1	5.77	4.62	11.8	21.5	7.59	4.22	15.6	34.7	9.63	3.83	19.7	52.6
		26	4.13	4.13	8.5	12.0	5.76	5.06	11.8	21.4	7.58	4.66	15.5	34.5	9.61	4.26	19.7	52.4
		27	4.12	4.12	8.4	12.0	5.74	5.49	11.8	21.3	7.56	5.09	15.5	34.4	9.59	4.70	19.7	52.2
		28	4.11	4.11	8.4	11.9	5.73	5.73	11.7	21.2	7.54	5.53	15.5	34.3	9.57	5.13	19.6	52.1
		29	4.09	4.09	8.4	11.9	5.72	5.72	11.7	21.1	7.53	5.97	15.4	34.2	9.56	5.57	19.6	51.9
	30	4.08	4.08	8.4	11.8	5.70	5.70	11.7	21.0	7.51	6.40	15.4	34.0	9.54	6.01	19.6	51.7	
	8	24	4.04	4.04	7.2	9.2	5.66	4.14	10.2	16.5	7.48	3.74	13.4	26.7	9.51	3.34	17.1	40.7
		25	4.02	4.02	7.2	9.1	5.65	4.57	10.1	16.4	7.46	4.18	13.4	26.6	9.49	3.78	17.0	40.6
26		4.01	4.01	7.2	9.1	5.63	5.01	10.1	16.3	7.45	4.61	13.4	26.5	9.48	4.22	17.0	40.4	
27		4.00	4.00	7.2	9.0	5.62	5.44	10.1	16.3	7.43	5.05	13.3	26.4	9.46	4.65	17.0	40.3	
28		3.99	3.99	7.2	9.0	5.60	5.60	10.1	16.2	7.42	5.48	13.3	26.3	9.44	5.09	16.9	40.2	
29		3.97	3.97	7.1	8.9	5.59	5.59	10.0	16.1	7.40	5.92	13.3	26.3	9.42	5.52	16.9	40.1	
30	3.96	3.96	7.1	8.9	5.58	5.58	10.0	16.1	7.38	6.35	13.2	26.2	9.41	5.96	16.9	39.9		

Note

- TC : Total capacity, SHC : Sensible Heat Capacity
- Performances are based on the following conditions :
 - Cooling
 - Condition A : Inlet/Outlet Water Temp. 7°C / 12°C, Indoor Air Temp. 27°CDB / 19°CWB
 - Condition B : Inlet/Outlet Water Temp. 10°C / 15°C, Indoor Air Temp. 27°CDB / 19°CWB
 - Condition C : Inlet/Outlet Water Temp. 7°C / 12°C, Indoor Air Temp. 25°CDB / 17.9°CWB
 - Condition D : Inlet/Outlet Water Temp. 14°C / 18°C, Indoor Air Temp. 26°CDB / 18°CWB
- Above capacity tables shows representative values according to the change in temperature or water flow rate, etc., it may vary depending on the installation conditions and the surrounding environment.

6. Capacity Tables

Inlet Water Temp. (°C)	Water Temp Difference (°C)	Air Temp (°C DB)	Air Temp(17°C WB)				Air Temp(19°C WB)				Air Temp(21°C WB)				Air Temp(23°C WB)			
			TC (kW)	SHC (kW)	Water Flow Rate (LPM)	Pressure Drop (kPa)	TC (kW)	SHC (kW)	Water Flow Rate (LPM)	Pressure Drop (kPa)	TC (kW)	SHC (kW)	Water Flow Rate (LPM)	Pressure Drop (kPa)	TC (kW)	SHC (kW)	Water Flow Rate (LPM)	Pressure Drop (kPa)
9	4	24	5.71	5.18	20.5	27.0	7.72	4.92	27.7	46.1	9.95	4.66	35.7	72.3	12.42	4.40	44.6	107.3
		25	5.70	5.61	20.4	26.9	7.71	5.35	27.7	45.9	9.94	5.09	35.7	72.1	12.40	4.83	44.5	107.0
		26	5.68	5.68	20.4	26.8	7.70	5.78	27.6	45.8	9.92	5.52	35.6	71.9	12.39	5.27	44.5	106.7
		27	5.67	5.67	20.4	26.7	7.68	6.21	27.6	45.7	9.91	5.96	35.6	71.7	12.37	5.70	44.4	106.5
		28	5.66	5.66	20.3	26.6	7.67	6.65	27.5	45.5	9.89	6.39	35.5	71.5	12.35	6.13	44.3	106.2
		29	5.65	5.65	20.3	26.5	7.65	7.08	27.5	45.4	9.88	6.82	35.4	71.3	12.34	6.56	44.3	105.9
	30	5.63	5.63	20.2	26.4	7.64	7.51	27.4	45.2	9.86	7.25	35.4	71.1	12.32	6.99	44.2	105.7	
	5	24	5.56	5.12	16.0	17.5	7.57	4.86	21.7	30.0	9.80	4.60	28.1	47.3	12.27	4.34	35.2	70.5
		25	5.55	5.55	15.9	17.4	7.56	5.29	21.7	29.9	9.79	5.03	28.1	47.2	12.25	4.77	35.2	70.3
		26	5.54	5.54	15.9	17.3	7.55	5.72	21.7	29.8	9.77	5.46	28.0	47.1	12.23	5.21	35.1	70.1
		27	5.52	5.52	15.9	17.3	7.53	6.16	21.6	29.7	9.75	5.90	28.0	46.9	12.21	5.64	35.1	69.9
		28	5.51	5.51	15.8	17.2	7.52	6.59	21.6	29.6	9.74	6.33	28.0	46.8	12.20	6.07	35.0	69.8
		29	5.50	5.50	15.8	17.1	7.50	7.02	21.5	29.5	9.72	6.76	27.9	46.7	12.18	6.50	35.0	69.6
	30	5.49	5.49	15.8	17.1	7.49	7.45	21.5	29.4	9.71	7.19	27.9	46.5	12.16	6.93	34.9	69.4	
	6	24	5.41	5.06	13.0	12.1	7.42	4.80	17.8	21.0	9.65	4.54	23.1	33.3	12.11	4.28	29.0	49.8
		25	5.40	5.40	12.9	12.1	7.41	5.23	17.7	21.0	9.63	4.97	23.0	33.2	12.09	4.71	28.9	49.7
		26	5.39	5.39	12.9	12.0	7.40	5.66	17.7	20.9	9.62	5.41	23.0	33.2	12.07	5.15	28.9	49.6
		27	5.38	5.38	12.9	12.0	7.38	6.10	17.7	20.8	9.60	5.84	23.0	33.1	12.06	5.58	28.8	49.4
		28	5.36	5.36	12.8	11.9	7.37	6.53	17.6	20.8	9.58	6.27	22.9	33.0	12.04	6.01	28.8	49.3
		29	5.35	5.35	12.8	11.9	7.35	6.96	17.6	20.7	9.57	6.70	22.9	32.9	12.02	6.44	28.8	49.2
	30	5.34	5.34	12.8	11.8	7.34	7.34	17.6	20.6	9.55	7.13	22.9	32.8	12.00	6.88	28.7	49.1	
	7	24	5.27	5.00	10.8	8.8	7.27	4.74	14.9	15.5	9.49	4.48	19.5	24.7	11.95	4.22	24.5	37.1
		25	5.25	5.25	10.8	8.8	7.26	5.17	14.9	15.4	9.48	4.91	19.4	24.6	11.93	4.65	24.5	37.0
		26	5.24	5.24	10.7	8.8	7.24	5.61	14.9	15.4	9.46	5.35	19.4	24.6	11.91	5.09	24.4	36.9
		27	5.23	5.23	10.7	8.7	7.23	6.04	14.8	15.3	9.44	5.78	19.4	24.5	11.90	5.52	24.4	36.8
		28	5.22	5.22	10.7	8.7	7.22	6.47	14.8	15.3	9.43	6.21	19.3	24.4	11.88	5.95	24.4	36.7
		29	5.20	5.20	10.7	8.6	7.20	6.90	14.8	15.2	9.41	6.64	19.3	24.3	11.86	6.38	24.3	36.6
	30	5.19	5.19	10.6	8.6	7.19	7.19	14.7	15.2	9.40	7.07	19.3	24.3	11.85	6.82	24.3	36.5	
	8	24	5.12	4.94	9.2	6.7	7.12	4.68	12.8	11.8	9.34	4.42	16.8	19.0	11.79	4.16	21.2	28.6
		25	5.10	5.10	9.2	6.6	7.11	5.11	12.7	11.8	9.32	4.86	16.7	18.9	11.77	4.60	21.1	28.5
26		5.09	5.09	9.1	6.6	7.09	5.55	12.7	11.7	9.30	5.29	16.7	18.9	11.75	5.03	21.1	28.5	
27		5.08	5.08	9.1	6.6	7.08	5.98	12.7	11.7	9.29	5.72	16.7	18.8	11.74	5.46	21.1	28.4	
28		5.07	5.07	9.1	6.6	7.06	6.41	12.7	11.7	9.27	6.15	16.6	18.8	11.72	5.89	21.0	28.3	
29		5.06	5.06	9.1	6.5	7.05	6.84	12.6	11.6	9.26	6.58	16.6	18.7	11.70	6.33	21.0	28.2	
30	5.04	5.04	9.0	6.5	7.04	7.04	12.6	11.6	9.24	7.02	16.6	18.7	11.69	6.76	21.0	28.2		

Note

- TC : Total capacity, SHC : Sensible Heat Capacity
- Performances are based on the following conditions :
 - Cooling
 - Condition A : Inlet/Outlet Water Temp. 7°C / 12°C, Indoor Air Temp. 27°CDB / 19°CWB
 - Condition B : Inlet/Outlet Water Temp. 10°C / 15°C, Indoor Air Temp. 27°CDB / 19°CWB
 - Condition C : Inlet/Outlet Water Temp. 7°C / 12°C, Indoor Air Temp. 25°CDB / 17.9°CWB
 - Condition D : Inlet/Outlet Water Temp. 14°C / 18°C, Indoor Air Temp. 26°CDB / 18°CWB
- Above capacity tables shows representative values according to the change in temperature or water flow rate, etc., it may vary depending on the installation conditions and the surrounding environment.

6. Capacity Tables

Inlet Water Temp. (°C)	Water Temp Difference (°C)	Air Temp (°C DB)	Air Temp(17°C WB)				Air Temp(19°C WB)				Air Temp(21°C WB)				Air Temp(23°C WB)			
			TC (kW)	SHC (kW)	Water Flow Rate (LPM)	Pressure Drop (kPa)	TC (kW)	SHC (kW)	Water Flow Rate (LPM)	Pressure Drop (kPa)	TC (kW)	SHC (kW)	Water Flow Rate (LPM)	Pressure Drop (kPa)	TC (kW)	SHC (kW)	Water Flow Rate (LPM)	Pressure Drop (kPa)
9	4	24	6.65	6.14	23.9	34.4	9.01	5.81	32.3	58.8	11.62	5.47	41.7	92.6	14.51	5.13	52.1	137.8
		25	6.63	6.63	23.8	34.3	8.99	6.33	32.3	58.7	11.60	5.99	41.6	92.3	14.49	5.65	52.0	137.5
		26	6.62	6.62	23.8	34.1	8.97	6.85	32.2	58.5	11.58	6.51	41.6	92.1	14.47	6.17	51.9	137.1
		27	6.60	6.60	23.7	34.0	8.96	7.37	32.1	58.3	11.56	7.03	41.5	91.8	14.45	6.69	51.9	136.8
		28	6.59	6.59	23.6	33.8	8.94	7.88	32.1	58.1	11.54	7.55	41.4	91.5	14.43	7.21	51.8	136.4
		29	6.57	6.57	23.6	33.7	8.92	8.40	32.0	57.9	11.53	8.07	41.4	91.3	14.41	7.73	51.7	136.1
	30	6.56	6.56	23.5	33.6	8.91	8.91	32.0	57.7	11.51	8.59	41.3	91.0	14.39	8.25	51.6	135.7	
	5	24	6.48	6.07	18.6	22.2	8.83	5.74	25.4	38.3	11.44	5.40	32.8	60.5	14.33	5.06	41.1	90.4
		25	6.46	6.46	18.6	22.1	8.81	6.26	25.3	38.1	11.42	5.92	32.8	60.4	14.31	5.58	41.1	90.2
		26	6.45	6.45	18.5	22.0	8.80	6.78	25.3	38.0	11.40	6.44	32.7	60.2	14.29	6.10	41.0	89.9
		27	6.43	6.43	18.5	21.9	8.78	7.30	25.2	37.9	11.38	6.96	32.7	60.0	14.27	6.62	41.0	89.7
		28	6.42	6.42	18.4	21.8	8.76	7.82	25.2	37.8	11.36	7.48	32.6	59.8	14.25	7.14	40.9	89.5
		29	6.40	6.40	18.4	21.7	8.75	8.34	25.1	37.6	11.35	8.00	32.6	59.7	14.23	7.66	40.8	89.2
	30	6.39	6.39	18.3	21.6	8.73	8.73	25.1	37.5	11.33	8.52	32.5	59.5	14.21	8.18	40.8	89.0	
	6	24	6.30	6.01	15.1	15.4	8.65	5.67	20.7	26.8	11.26	5.33	26.9	42.6	14.14	4.99	33.8	63.8
		25	6.29	6.29	15.0	15.3	8.64	6.19	20.7	26.7	11.24	5.85	26.9	42.5	14.12	5.51	33.8	63.7
		26	6.27	6.27	15.0	15.2	8.62	6.71	20.6	26.6	11.22	6.37	26.8	42.3	14.10	6.03	33.7	63.5
		27	6.26	6.26	15.0	15.2	8.60	7.23	20.6	26.5	11.20	6.89	26.8	42.2	14.08	6.56	33.7	63.3
		28	6.24	6.24	14.9	15.1	8.59	7.75	20.5	26.4	11.18	7.41	26.8	42.1	14.06	7.08	33.6	63.2
		29	6.23	6.23	14.9	15.1	8.57	8.27	20.5	26.3	11.16	7.93	26.7	42.0	14.04	7.60	33.6	63.0
	30	6.22	6.22	14.9	15.0	8.55	8.55	20.5	26.2	11.15	8.45	26.7	41.8	14.02	8.12	33.5	62.9	
	7	24	6.13	5.94	12.6	11.2	8.48	5.60	17.4	19.7	11.08	5.26	22.7	31.5	13.96	4.92	28.6	47.4
		25	6.12	6.12	12.5	11.1	8.46	6.12	17.3	19.6	11.06	5.78	22.7	31.4	13.94	5.45	28.6	47.3
		26	6.10	6.10	12.5	11.1	8.44	6.64	17.3	19.6	11.04	6.30	22.6	31.3	13.92	5.97	28.5	47.2
		27	6.09	6.09	12.5	11.0	8.43	7.16	17.3	19.5	11.02	6.82	22.6	31.2	13.90	6.49	28.5	47.1
		28	6.07	6.07	12.5	11.0	8.41	7.68	17.2	19.4	11.00	7.34	22.6	31.2	13.87	7.01	28.5	46.9
		29	6.06	6.06	12.4	10.9	8.39	8.20	17.2	19.4	10.98	7.86	22.5	31.1	13.85	7.53	28.4	46.8
	30	6.04	6.04	12.4	10.9	8.38	8.38	17.2	19.3	10.96	8.38	22.5	31.0	13.83	8.05	28.4	46.7	
	8	24	5.96	5.87	10.7	8.4	8.30	5.53	14.9	15.0	10.89	5.19	19.5	24.2	13.77	4.86	24.7	36.6
		25	5.94	5.94	10.7	8.4	8.28	6.05	14.9	15.0	10.87	5.71	19.5	24.1	13.75	5.38	24.7	36.5
26		5.93	5.93	10.6	8.4	8.26	6.57	14.8	14.9	10.86	6.23	19.5	24.1	13.73	5.90	24.6	36.4	
27		5.91	5.91	10.6	8.3	8.25	7.09	14.8	14.9	10.84	6.75	19.4	24.0	13.71	6.42	24.6	36.3	
28		5.90	5.90	10.6	8.3	8.23	7.61	14.8	14.8	10.82	7.27	19.4	23.9	13.69	6.94	24.6	36.2	
29		5.88	5.88	10.6	8.3	8.21	8.13	14.7	14.8	10.80	7.79	19.4	23.8	13.67	7.46	24.5	36.1	
30	5.87	5.87	10.5	8.2	8.20	8.20	14.7	14.7	10.78	8.31	19.3	23.8	13.65	7.98	24.5	36.0		

Note

- TC : Total capacity, SHC : Sensible Heat Capacity
- Performances are based on the following conditions :
 - Cooling
 - Condition A : Inlet/Outlet Water Temp. 7°C / 12°C, Indoor Air Temp. 27°CDB / 19°CWB
 - Condition B : Inlet/Outlet Water Temp. 10°C / 15°C, Indoor Air Temp. 27°CDB / 19°CWB
 - Condition C : Inlet/Outlet Water Temp. 7°C / 12°C, Indoor Air Temp. 25°CDB / 17.9°CWB
 - Condition D : Inlet/Outlet Water Temp. 14°C / 18°C, Indoor Air Temp. 26°CDB / 18°CWB
- Above capacity tables shows representative values according to the change in temperature or water flow rate, etc., it may vary depending on the installation conditions and the surrounding environment.

6. Capacity Tables

Inlet Water Temp. (°C)	Water Temp Difference (°C)	Air Temp (°C DB)	Air Temp(17°C WB)				Air Temp(19°C WB)				Air Temp(21°C WB)				Air Temp(23°C WB)			
			TC (kW)	SHC (kW)	Water Flow Rate (LPM)	Pressure Drop (kPa)	TC (kW)	SHC (kW)	Water Flow Rate (LPM)	Pressure Drop (kPa)	TC (kW)	SHC (kW)	Water Flow Rate (LPM)	Pressure Drop (kPa)	TC (kW)	SHC (kW)	Water Flow Rate (LPM)	Pressure Drop (kPa)
9	4	24	8.23	7.61	29.5	51.4	11.15	7.19	40.0	88.1	14.39	6.77	51.6	138.8	17.97	6.35	64.5	207.0
		25	8.21	8.21	29.5	51.2	11.13	7.83	39.9	87.8	14.36	7.42	51.5	138.4	17.94	7.00	64.4	206.5
		26	8.19	8.19	29.4	51.0	11.11	8.48	39.9	87.5	14.34	8.06	51.5	138.0	17.92	7.64	64.3	206.0
		27	8.18	8.18	29.3	50.7	11.09	9.12	39.8	87.2	14.32	8.70	51.4	137.6	17.89	8.29	64.2	205.4
		28	8.16	8.16	29.3	50.5	11.07	9.76	39.7	86.9	14.29	9.35	51.3	137.3	17.87	8.93	64.1	204.9
		29	8.14	8.14	29.2	50.3	11.05	10.40	39.6	86.6	14.27	9.99	51.2	136.9	17.84	9.57	64.0	204.4
	30	8.12	8.12	29.1	50.1	11.03	11.03	39.6	86.3	14.25	10.63	51.1	136.5	17.82	10.22	63.9	203.9	
	5	24	8.02	7.52	23.0	33.1	10.93	7.10	31.4	57.2	14.16	6.69	40.7	90.6	17.74	6.27	50.9	135.5
		25	8.00	8.00	23.0	32.9	10.91	7.75	31.3	57.0	14.14	7.33	40.6	90.4	17.72	6.91	50.9	135.2
		26	7.98	7.98	22.9	32.8	10.89	8.39	31.3	56.8	14.12	7.97	40.5	90.1	17.69	7.56	50.8	134.8
		27	7.96	7.96	22.9	32.7	10.87	9.03	31.2	56.6	14.09	8.62	40.5	89.8	17.66	8.20	50.7	134.5
		28	7.95	7.95	22.8	32.5	10.85	9.68	31.1	56.4	14.07	9.26	40.4	89.6	17.64	8.85	50.6	134.2
		29	7.93	7.93	22.8	32.4	10.83	10.32	31.1	56.2	14.05	9.90	40.3	89.3	17.61	9.49	50.6	133.8
	30	7.91	7.91	22.7	32.3	10.81	10.81	31.0	56.0	14.02	10.55	40.3	89.0	17.59	10.13	50.5	133.5	
	6	24	7.81	7.44	18.7	22.9	10.71	7.02	25.6	40.0	13.94	6.60	33.3	63.7	17.51	6.18	41.9	95.6
		25	7.79	7.79	18.6	22.8	10.69	7.66	25.6	39.8	13.91	7.24	33.3	63.5	17.49	6.83	41.8	95.4
		26	7.77	7.77	18.6	22.7	10.67	8.31	25.5	39.7	13.89	7.89	33.2	63.3	17.46	7.47	41.8	95.1
		27	7.75	7.75	18.5	22.6	10.65	8.95	25.5	39.6	13.87	8.53	33.2	63.1	17.43	8.12	41.7	94.9
		28	7.73	7.73	18.5	22.5	10.63	9.59	25.4	39.4	13.85	9.18	33.1	62.9	17.41	8.76	41.7	94.6
		29	7.71	7.71	18.5	22.4	10.61	10.24	25.4	39.3	13.82	9.82	33.1	62.7	17.38	9.40	41.6	94.4
	30	7.70	7.70	18.4	22.3	10.59	10.59	25.3	39.1	13.80	10.46	33.0	62.6	17.36	10.05	41.5	94.1	
	7	24	7.59	7.35	15.6	16.6	10.50	6.93	21.5	29.4	13.71	6.52	28.1	47.1	17.28	6.10	35.4	71.0
		25	7.57	7.57	15.5	16.6	10.47	7.58	21.5	29.3	13.69	7.16	28.1	46.9	17.26	6.74	35.4	70.8
		26	7.55	7.55	15.5	16.5	10.45	8.22	21.4	29.1	13.67	7.80	28.0	46.8	17.23	7.39	35.3	70.6
		27	7.54	7.54	15.5	16.4	10.43	8.86	21.4	29.0	13.64	8.45	28.0	46.6	17.20	8.03	35.3	70.4
		28	7.52	7.52	15.4	16.3	10.41	9.51	21.4	28.9	13.62	9.09	27.9	46.5	17.18	8.68	35.2	70.2
		29	7.50	7.50	15.4	16.3	10.39	10.15	21.3	28.8	13.60	9.74	27.9	46.4	17.15	9.32	35.2	70.0
	30	7.48	7.48	15.3	16.2	10.37	10.37	21.3	28.7	13.57	10.38	27.8	46.2	17.13	9.96	35.1	69.8	
	8	24	7.38	7.27	13.2	12.5	10.27	6.85	18.4	22.4	13.49	6.43	24.2	36.1	17.05	6.01	30.6	54.6
		25	7.36	7.36	13.2	12.5	10.25	7.49	18.4	22.3	13.46	7.07	24.2	36.0	17.02	6.66	30.5	54.5
26		7.34	7.34	13.2	12.4	10.23	8.13	18.4	22.2	13.44	7.72	24.1	35.9	17.00	7.30	30.5	54.4	
27		7.32	7.32	13.1	12.4	10.21	8.78	18.3	22.1	13.42	8.36	24.1	35.8	16.97	7.95	30.5	54.2	
28		7.30	7.30	13.1	12.3	10.19	9.42	18.3	22.0	13.39	9.01	24.0	35.7	16.95	8.59	30.4	54.1	
29		7.28	7.28	13.1	12.2	10.17	10.07	18.2	22.0	13.37	9.65	24.0	35.5	16.92	9.23	30.4	53.9	
30	7.27	7.27	13.0	12.2	10.15	10.15	18.2	21.9	13.35	10.29	23.9	35.4	16.90	9.88	30.3	53.8		

Note

- TC : Total capacity, SHC : Sensible Heat Capacity
- Performances are based on the following conditions :
 - Cooling
 - Condition A : Inlet/Outlet Water Temp. 7°C / 12°C, Indoor Air Temp. 27°CDB / 19°CWB
 - Condition B : Inlet/Outlet Water Temp. 10°C / 15°C, Indoor Air Temp. 27°CDB / 19°CWB
 - Condition C : Inlet/Outlet Water Temp. 7°C / 12°C, Indoor Air Temp. 25°CDB / 17.9°CWB
 - Condition D : Inlet/Outlet Water Temp. 14°C / 18°C, Indoor Air Temp. 26°CDB / 18°CWB
- Above capacity tables shows representative values according to the change in temperature or water flow rate, etc., it may vary depending on the installation conditions and the surrounding environment.

6. Capacity Tables

6.2 Heating Capacity

◆ WF4A060CG0B

Water Temp Difference (°C)	Air Temp (°C DB)	Inlet Water Temp.(°C)														
		40			45			50			55			60		
		TC (kW)	Water Flow Rate (LPM)	Pressure Drop (kPa)	TC (kW)	Water Flow Rate (LPM)	Pressure Drop (kPa)	TC (kW)	Water Flow Rate (LPM)	Pressure Drop (kPa)	TC (kW)	Water Flow Rate (LPM)	Pressure Drop (kPa)	TC (kW)	Water Flow Rate (LPM)	Pressure Drop (kPa)
4	16	6.57	23.6	75.6	7.99	28.7	106.8	9.41	33.8	142.7	-	-	-	-	-	-
	18	6.01	21.6	64.5	7.42	26.6	93.8	8.84	31.7	127.8	10.26	36.8	166.4	-	-	-
	20	5.44	19.5	54.2	6.86	24.6	81.5	8.27	29.7	113.6	9.69	34.8	150.4	-	-	-
	22	4.87	17.5	44.7	6.29	22.6	70.0	7.71	27.7	100.2	9.12	32.7	135.1	-	-	-
5	24	4.31	15.5	36.0	5.72	20.5	59.3	7.14	25.6	87.5	8.56	30.7	120.6	9.97	35.8	158.3
	16	6.52	18.7	50.3	7.93	22.8	71.1	9.35	26.8	95.0	10.77	30.9	122.0	12.18	35.0	151.9
	18	5.95	17.1	42.9	7.37	21.1	62.4	8.78	25.2	85.1	10.20	29.3	110.9	11.62	33.3	139.6
	20	5.38	15.5	36.0	6.80	19.5	54.2	8.22	23.6	75.6	9.63	27.7	100.2	11.05	31.7	127.8
6	22	4.82	13.8	29.6	6.23	17.9	46.5	7.65	22.0	66.7	9.07	26.0	90.0	10.48	30.1	116.4
	24	4.25	12.2	23.8	5.67	16.3	39.4	7.08	20.3	58.2	8.50	24.4	80.3	9.92	28.5	105.5
	16	6.46	15.5	36.0	7.88	18.8	50.9	9.29	22.2	68.1	10.71	25.6	87.5	12.13	29.0	109.0
	18	5.89	14.1	30.7	7.31	17.5	44.7	8.73	20.9	61.0	10.14	24.3	79.5	11.56	27.7	100.2
7	20	5.33	12.7	25.7	6.74	16.1	38.8	8.16	19.5	54.2	9.58	22.9	71.8	10.99	26.3	91.7
	22	4.76	11.4	21.1	6.18	14.8	33.3	7.59	18.2	47.8	9.01	21.6	64.5	10.43	24.9	83.5
	24	4.19	10.0	17.0	5.61	13.4	28.1	7.03	16.8	41.7	8.44	20.2	57.6	9.86	23.6	75.6
	16	6.40	13.1	27.1	7.82	16.0	38.4	9.24	18.9	51.4	10.65	21.8	66.1	12.07	24.8	82.3
8	18	5.84	12.0	23.0	7.25	14.9	33.7	8.67	17.8	46.0	10.09	20.7	60.0	11.50	23.6	75.6
	20	5.27	10.8	19.3	6.69	13.7	29.2	8.10	16.6	40.9	9.52	19.5	54.2	10.94	22.4	69.2
	22	4.70	9.6	15.8	6.12	12.5	25.0	7.54	15.5	36.0	8.95	18.4	48.7	10.37	21.3	63.0
	24	4.14	8.5	12.7	5.55	11.4	21.1	6.97	14.3	31.4	8.39	17.2	43.4	9.80	20.1	57.1
9	16	6.35	11.4	21.1	7.76	13.9	30.0	9.18	16.5	40.2	10.60	19.0	51.7	12.01	21.6	64.5
	18	5.78	10.4	18.0	7.20	12.9	26.3	8.61	15.5	36.0	10.03	18.0	47.0	11.45	20.5	59.3
	20	5.21	9.4	15.0	6.63	11.9	22.8	8.05	14.4	31.9	9.46	17.0	42.4	10.88	19.5	54.2
	22	4.65	8.3	12.3	6.06	10.9	19.5	7.48	13.4	28.1	8.90	16.0	38.1	10.31	18.5	49.3
24	4.08	7.3	9.8	5.50	9.9	16.5	6.91	12.4	24.5	8.33	14.9	33.9	9.75	17.5	44.7	

Note

- TC : Total capacity
- Performances are based on the following conditions :
 - Heating
 - Condition A : Inlet/Outlet Water Temp. 45°C / 40°C, Indoor Air Temp. 20°CDB / 15°CWB
 - Condition B : Inlet Water Temp. 50°C, Indoor Air Temp. 20°CDB / 15°CWB
- Above capacity tables shows representative values according to the change in temperature or water flow rate, etc., it may vary depending on the installation conditions and the surrounding environment.

◆ WF4A072CG0B

Water Temp Difference (°C)	Air Temp (°C DB)	Inlet Water Temp.(°C)														
		40			45			50			55			60		
		TC (kW)	Water Flow Rate (LPM)	Pressure Drop (kPa)	TC (kW)	Water Flow Rate (LPM)	Pressure Drop (kPa)	TC (kW)	Water Flow Rate (LPM)	Pressure Drop (kPa)	TC (kW)	Water Flow Rate (LPM)	Pressure Drop (kPa)	TC (kW)	Water Flow Rate (LPM)	Pressure Drop (kPa)
4	16	7.83	28.1	102.8	9.52	34.2	145.4	-	-	-	-	-	-	-	-	-
	18	7.16	25.7	87.7	8.84	31.7	127.6	-	-	-	-	-	-	-	-	-
	20	6.48	23.3	73.6	8.17	29.3	110.8	9.86	35.4	154.6	-	-	-	-	-	-
	22	5.81	20.8	60.6	7.49	26.9	95.1	9.18	32.9	136.3	-	-	-	-	-	-
5	24	5.13	18.4	48.8	6.82	24.5	80.5	8.51	30.5	119.1	10.19	36.6	164.2	-	-	-
	16	7.76	22.3	68.3	9.45	27.1	96.6	11.14	32.0	129.3	12.83	36.8	166.1	-	-	-
	18	7.09	20.3	58.2	8.78	25.2	84.8	10.46	30.0	115.7	12.15	34.9	150.9	-	-	-
	20	6.41	18.4	48.8	8.10	23.3	73.6	9.79	28.1	102.8	11.48	32.9	136.3	-	-	-
6	22	5.74	16.5	40.1	7.43	21.3	63.1	9.11	26.2	90.6	10.80	31.0	122.4	12.49	35.8	158.4
	24	5.06	14.5	32.3	6.75	19.4	53.4	8.44	24.2	79.1	10.13	29.1	109.2	11.81	33.9	143.5
	16	7.70	18.4	48.8	9.38	22.4	69.2	11.07	26.5	92.6	12.76	30.5	119.1	14.45	34.6	148.4
	18	7.02	16.8	41.5	8.71	20.8	60.6	10.40	24.9	82.9	12.08	28.9	108.1	13.77	32.9	136.3
7	20	6.35	15.2	34.8	8.03	19.2	52.6	9.72	23.3	73.6	11.41	27.3	97.7	13.10	31.3	124.7
	22	5.67	13.6	28.6	7.36	17.6	45.1	9.05	21.6	64.8	10.73	25.7	87.7	12.42	29.7	113.5
	24	5.00	11.9	22.9	6.68	16.0	38.1	8.37	20.0	56.6	10.06	24.1	78.2	11.75	28.1	102.8
	16	7.63	15.6	36.7	9.32	19.1	52.1	11.00	22.6	69.8	12.69	26.0	89.8	14.38	29.5	112.0
8	18	6.95	14.3	31.2	8.64	17.7	45.6	10.33	21.2	62.4	12.02	24.6	81.5	13.70	28.1	102.8
	20	6.28	12.9	26.1	7.97	16.3	39.6	9.65	19.8	55.4	11.34	23.3	73.6	13.03	26.7	94.0
	22	5.60	11.5	21.4	7.29	14.9	33.9	8.98	18.4	48.8	10.67	21.9	66.1	12.35	25.3	85.6
	24	4.93	10.1	17.1	6.62	13.6	28.6	8.30	17.0	42.5	9.99	20.5	58.9	11.68	23.9	77.5
9	16	7.56	13.6	28.6	9.25	16.6	40.7	10.94	19.6	54.6	12.62	22.6	70.3	14.31	25.7	87.7
	18	6.89	12.4	24.3	8.57	15.4	35.6	10.26	18.4	48.8	11.95	21.4	63.8	13.64	24.5	80.5
	20	6.21	11.1	20.3	7.90	14.2	30.9	9.59	17.2	43.3	11.27	20.2	57.6	12.96	23.3	73.6
	22	5.54	9.9	16.6	7.22	13.0	26.4	8.91	16.0	38.1	10.60	19.0	51.6	12.29	22.0	67.0
24	4.86	8.7	13.3	6.55	11.7	22.3	8.24	14.8	33.2	9.92	17.8	46.0	11.61	20.8	60.6	

Note

- TC : Total capacity
- Performances are based on the following conditions :
 - Heating
 - Condition A : Inlet/Outlet Water Temp. 45°C / 40°C, Indoor Air Temp. 20°CDB / 15°CWB
 - Condition B : Inlet Water Temp. 50°C, Indoor Air Temp. 20°CDB / 15°CWB
- Above capacity tables shows representative values according to the change in temperature or water flow rate, etc., it may vary depending on the installation conditions and the surrounding environment.

6. Capacity Tables

◆ WF4A090CG0B

Water Temp Difference (°C)	Air Temp (°C DB)	Inlet Water Temp.(°C)														
		40			45			50			55			60		
		TC (kW)	Water Flow Rate (LPM)	Pressure Drop (kPa)	TC (kW)	Water Flow Rate (LPM)	Pressure Drop (kPa)	TC (kW)	Water Flow Rate (LPM)	Pressure Drop (kPa)	TC (kW)	Water Flow Rate (LPM)	Pressure Drop (kPa)	TC (kW)	Water Flow Rate (LPM)	Pressure Drop (kPa)
4	16	8.22	29.5	48.9	9.99	35.8	69.2	11.76	42.2	92.5	13.53	48.5	118.9	15.30	54.9	148.2
	18	7.51	26.9	41.7	9.28	33.3	60.7	11.05	39.7	82.8	12.82	46.0	108.0	14.59	52.4	136.1
	20	6.80	24.4	35.0	8.57	30.8	52.7	10.34	37.1	73.6	12.11	43.5	97.5	13.88	49.8	124.5
	22	6.09	21.9	28.8	7.86	28.2	45.2	9.63	34.6	64.9	11.40	40.9	87.6	13.18	47.3	113.4
	24	5.38	19.3	23.2	7.15	25.7	38.3	8.93	32.0	56.6	10.70	38.4	78.1	12.47	44.7	102.7
5	16	8.15	23.4	32.5	9.92	28.5	46.0	11.69	33.6	61.5	13.46	38.6	79.1	15.23	43.7	98.6
	18	7.44	21.4	27.7	9.21	26.4	40.3	10.98	31.5	55.1	12.75	36.6	71.8	14.52	41.7	90.5
	20	6.73	19.3	23.2	8.50	24.4	35.0	10.27	29.5	48.9	12.04	34.6	64.9	13.81	39.7	82.8
	22	6.02	17.3	19.1	7.79	22.4	30.0	9.56	27.5	43.1	11.33	32.5	58.2	13.10	37.6	75.4
	24	5.31	15.3	15.3	7.08	20.3	25.4	8.85	25.4	37.6	37.6	30.5	51.9	12.40	35.6	68.3
6	16	8.08	19.3	23.2	9.85	23.6	32.9	11.62	27.8	44.0	13.39	32.0	56.6	15.16	36.3	70.6
	18	7.37	17.6	19.7	9.14	21.9	28.8	10.91	26.1	39.4	12.68	30.3	51.4	14.45	34.6	64.9
	20	6.66	15.9	16.5	8.43	20.2	25.0	10.20	24.4	35.0	11.97	28.6	46.5	13.74	32.9	59.3
	22	5.95	14.2	13.6	7.72	18.5	21.4	9.49	22.7	30.8	11.26	26.9	41.7	13.03	31.2	54.0
	24	5.24	12.5	10.9	7.01	16.8	18.1	8.78	21.0	26.9	10.55	25.2	37.2	12.33	29.5	48.9
7	16	8.00	16.4	17.4	9.78	20.0	24.7	11.55	23.7	33.2	13.32	27.3	42.7	15.09	30.9	53.3
	18	7.30	15.0	14.8	9.07	18.6	21.7	10.84	22.2	29.7	12.61	25.9	38.8	14.38	29.5	48.9
	20	6.59	13.5	12.4	8.36	17.1	18.8	10.13	20.8	26.3	11.90	24.4	35.0	13.67	28.0	44.7
	22	5.88	12.1	10.2	7.65	15.7	16.1	9.42	19.3	23.2	11.19	22.9	31.4	12.96	26.6	40.7
	24	5.17	10.6	8.1	6.94	14.2	13.6	8.71	17.9	20.2	10.48	21.5	28.0	12.25	25.1	36.9
8	16	7.93	14.2	13.6	9.70	17.4	19.3	11.48	20.6	25.9	13.25	23.8	33.4	15.02	26.9	41.7
	18	7.23	13.0	11.5	9.00	16.1	16.9	10.77	19.3	23.2	12.54	22.5	30.3	14.31	25.7	38.3
	20	6.52	11.7	9.6	8.29	14.9	14.7	10.06	18.0	20.6	11.83	21.2	27.4	13.60	24.4	35.0
	22	5.81	10.4	7.9	7.58	13.6	12.5	9.35	16.8	18.1	11.12	20.0	24.6	12.89	23.1	31.8
	24	5.10	9.2	6.3	6.87	12.3	10.6	8.64	15.5	15.8	10.41	18.7	21.9	12.18	21.9	28.8

Note

- TC : Total capacity
- Performances are based on the following conditions :
 - Heating
 - Condition A : Inlet/Outlet Water Temp. 45°C / 40°C, Indoor Air Temp. 20°CDB / 15°CWB
 - Condition B : Inlet Water Temp. 50°C, Indoor Air Temp. 20°CDB / 15°CWB
- Above capacity tables shows representative values according to the change in temperature or water flow rate, etc., it may vary depending on the installation conditions and the surrounding environment.

◆ WF4A105CG0B

Water Temp Difference (°C)	Air Temp (°C DB)	Inlet Water Temp.(°C)														
		40			45			50			55			60		
		TC (kW)	Water Flow Rate (LPM)	Pressure Drop (kPa)	TC (kW)	Water Flow Rate (LPM)	Pressure Drop (kPa)	TC (kW)	Water Flow Rate (LPM)	Pressure Drop (kPa)	TC (kW)	Water Flow Rate (LPM)	Pressure Drop (kPa)	TC (kW)	Water Flow Rate (LPM)	Pressure Drop (kPa)
4	16	8.89	31.9	57.7	10.81	38.8	81.7	12.73	45.7	109.3	14.64	52.5	140.5	16.56	59.4	175.2
	18	8.13	29.2	49.2	10.04	36.0	71.7	11.96	42.9	97.8	13.88	49.8	127.6	15.79	56.7	160.9
	20	7.36	26.4	41.3	9.28	33.3	62.2	11.19	40.2	86.9	13.11	47.0	115.3	15.03	53.9	147.2
	22	6.59	23.7	34.0	8.51	30.5	53.4	10.43	37.4	76.6	12.34	44.3	103.5	14.26	51.2	134.0
	24	5.83	20.9	27.4	7.74	27.8	45.2	9.66	34.7	66.9	11.58	41.5	92.3	13.49	48.4	121.4
5	16	8.82	25.3	38.3	10.73	30.8	54.3	12.65	36.3	72.7	14.57	41.8	93.4	16.48	47.3	116.5
	18	8.05	23.1	32.6	9.97	28.6	47.6	11.88	34.1	65.0	13.80	39.6	84.8	15.72	45.1	107.0
	20	7.28	20.9	27.4	9.20	26.4	41.3	11.12	31.9	57.7	13.03	37.4	76.6	14.95	42.9	97.8
	22	6.52	18.7	22.5	8.43	24.2	35.4	10.35	29.7	50.9	12.27	35.2	68.8	14.18	40.7	89.1
	24	5.75	16.5	18.1	7.67	22.0	29.9	9.58	27.5	44.4	11.50	33.0	61.3	13.42	38.5	80.7
6	16	8.74	20.9	27.4	10.66	25.5	38.8	12.57	30.1	52.0	14.49	34.7	66.9	16.41	39.3	83.4
	18	7.97	19.1	23.3	9.89	23.7	34.0	11.81	28.2	46.5	13.72	32.8	60.7	15.64	37.4	76.6
	20	7.21	17.2	19.5	9.12	21.8	29.5	11.04	26.4	41.3	12.96	31.0	54.8	14.87	35.6	70.1
	22	6.44	15.4	16.0	8.36	20.0	25.3	10.27	24.6	36.4	12.19	29.2	49.2	14.11	33.7	63.8
	24	5.67	13.6	12.8	7.59	18.2	21.3	9.51	22.7	31.7	11.42	27.3	43.9	13.34	31.9	57.7
7	16	8.66	17.8	20.5	10.58	21.7	29.2	12.50	25.6	39.2	14.41	29.6	50.4	16.33	33.5	62.9
	18	7.90	16.2	17.5	9.81	20.1	25.6	11.73	24.1	35.0	13.65	28.0	45.7	15.56	31.9	57.7
	20	7.13	14.6	14.6	9.05	18.6	22.2	10.96	22.5	31.1	12.88	26.4	41.3	14.80	30.3	52.8
	22	6.36	13.0	12.0	8.28	17.0	19.0	10.20	20.9	27.4	12.11	24.8	37.1	14.03	28.8	48.0
	24	5.60	11.5	9.6	7.51	15.4	16.0	9.43	19.3	23.8	11.35	23.3	33.0	13.26	27.2	43.5
8	16	8.59	15.4	16.0	10.50	18.8	22.8	12.42	22.3	30.6	14.34	25.7	39.4	16.25	29.2	49.2
	18	7.82	14.0	13.6	9.74	17.5	19.9	11.65	20.9	27.4	13.57	24.3	35.8	15.49	27.8	45.2
	20	7.05	12.7	11.4	8.97	16.1	17.3	10.89	19.5	24.3	12.80	23.0	32.3	14.72	26.4	41.3
	22	6.29	11.3	9.3	8.20	14.7	14.8	10.12	18.2	21.3	12.04	21.6	29.0	13.95	25.0	37.6
	24	5.52	9.9	7.4	7.44	13.3	12.5	9.35	16.8	18.6	11.27	20.2	25.8	13.19	23.7	34.0

Note

- TC : Total capacity
- Performances are based on the following conditions :
 - Heating
 - Condition A : Inlet/Outlet Water Temp. 45°C / 40°C, Indoor Air Temp. 20°CDB / 15°CWB
 - Condition B : Inlet Water Temp. 50°C, Indoor Air Temp. 20°CDB / 15°CWB
- Above capacity tables shows representative values according to the change in temperature or water flow rate, etc., it may vary depending on the installation conditions and the surrounding environment.

6. Capacity Tables

◆ WF4A130CG0B

Water Temp Difference (°C)	Air Temp (°C DB)	Inlet Water Temp.(°C)														
		40			45			50			55			60		
		TC (kW)	Water Flow Rate (LPM)	Pressure Drop (kPa)	TC (kW)	Water Flow Rate (LPM)	Pressure Drop (kPa)	TC (kW)	Water Flow Rate (LPM)	Pressure Drop (kPa)	TC (kW)	Water Flow Rate (LPM)	Pressure Drop (kPa)	TC (kW)	Water Flow Rate (LPM)	Pressure Drop (kPa)
4	16	10.34	37.1	79.2	12.57	45.1	112.2	14.80	53.1	150.3	17.03	61.1	193.3	-	-	-
	18	9.45	33.9	67.5	11.68	41.9	98.4	13.91	49.9	134.4	16.14	57.9	175.5	-	-	-
	20	8.56	30.7	56.6	10.79	38.7	85.4	13.02	46.7	119.4	15.25	54.7	158.5	17.48	62.7	202.5
	22	7.67	27.5	46.6	9.90	35.5	73.2	12.13	43.5	105.2	14.36	51.5	142.2	16.59	59.5	184.3
	24	6.78	24.3	37.4	9.01	32.3	61.9	11.24	40.3	91.8	13.46	48.3	126.8	15.69	56.3	166.9
5	16	10.25	29.4	52.5	12.48	35.8	74.4	14.71	42.2	99.7	16.94	48.6	128.3	19.17	55.0	160.1
	18	9.36	26.9	44.7	11.59	33.3	65.2	13.82	39.7	89.2	16.05	46.1	116.5	18.28	52.5	147.0
	20	8.47	24.3	37.4	10.70	30.7	56.6	12.93	37.1	79.2	15.16	43.5	105.2	17.39	49.9	134.4
	22	7.58	21.8	30.8	9.81	28.2	48.5	12.04	34.6	69.8	14.27	41.0	94.4	16.50	47.4	122.3
	24	6.69	19.2	24.7	8.92	25.6	41.0	11.15	32.0	60.9	13.38	38.4	84.1	15.60	44.8	110.8
6	16	10.17	24.3	37.4	12.39	29.7	53.2	14.62	35.0	71.3	16.85	40.3	91.8	19.08	45.6	114.6
	18	9.27	22.2	31.8	11.50	27.5	46.6	13.73	32.9	63.8	15.96	38.2	83.3	18.19	43.5	105.2
	20	8.38	20.1	26.6	10.61	25.4	40.4	12.84	30.7	56.6	15.07	36.1	75.2	17.30	41.4	96.2
	22	7.49	17.9	21.9	9.72	23.3	34.6	11.95	28.6	49.8	14.18	33.9	67.5	16.41	39.3	87.5
	24	6.60	15.8	17.5	8.83	21.1	29.2	11.06	26.5	43.4	13.29	31.8	60.1	15.52	37.1	79.2
7	16	10.08	20.7	28.1	12.31	25.2	40.0	14.53	29.8	53.6	16.76	34.4	69.1	18.99	38.9	86.3
	18	9.18	18.8	23.9	11.41	23.4	35.0	13.64	28.0	48.0	15.87	32.5	62.7	18.10	37.1	79.2
	20	8.29	17.0	20.0	10.52	21.6	30.3	12.75	26.1	42.6	14.98	30.7	56.6	17.21	35.3	72.4
	22	7.40	15.2	16.4	9.63	19.7	25.9	11.86	24.3	37.4	14.09	28.9	50.8	16.32	33.5	65.9
	24	6.51	13.3	13.1	8.74	17.9	21.9	10.97	22.5	32.6	13.20	27.1	45.2	15.43	31.6	59.6
8	16	9.99	17.9	21.9	12.22	21.9	31.2	14.45	25.9	41.9	16.67	29.9	54.0	18.90	33.9	67.5
	18	9.10	16.3	18.6	11.32	20.3	27.3	13.55	24.3	37.4	15.78	28.3	49.0	18.01	32.3	61.9
	20	8.20	14.7	15.5	10.43	18.7	23.6	12.66	22.7	33.2	14.89	26.7	44.2	17.12	30.7	56.6
	22	7.31	13.1	12.7	9.54	17.1	20.2	11.77	21.1	29.2	14.00	25.1	39.6	16.23	29.1	51.5
	24	6.42	11.5	10.1	8.65	15.5	17.0	10.88	19.5	25.4	13.11	23.5	35.3	15.34	27.5	46.6

Note

1. TC : Total capacity
2. Performances are based on the following conditions :
 - 1) Heating
 - Condition A : Inlet/Outlet Water Temp. 45°C / 40°C, Indoor Air Temp. 20°CDB / 15°CWB
 - Condition B : Inlet Water Temp. 50°C, Indoor Air Temp. 20°CDB / 15°CWB
3. Above capacity tables shows representative values according to the change in temperature or water flow rate, etc., it may vary depending on the installation conditions and the surrounding environment.

7. Air Velocity and Temperature Distribution(Reference Data)

◆ WF4A060CG0B

Cooling

Discharge angle: Outer - 30°, Inner - 67°

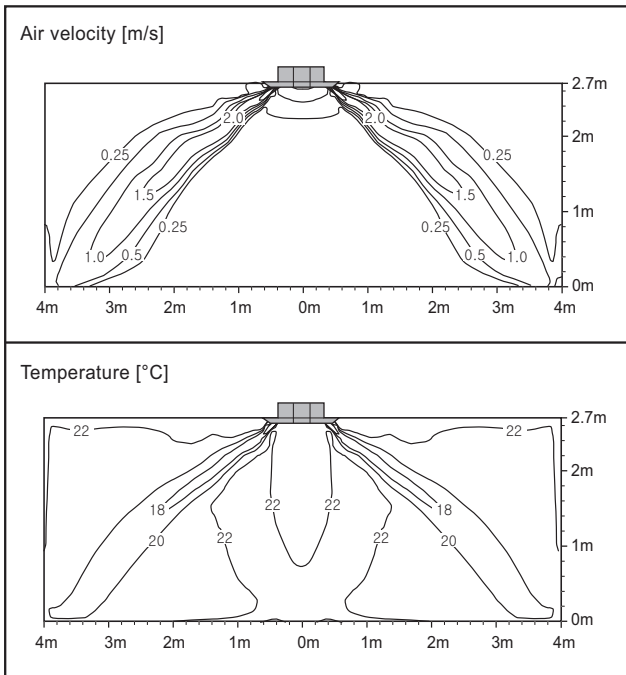

Heating

Discharge angle: Outer - 36°, Inner - 70°

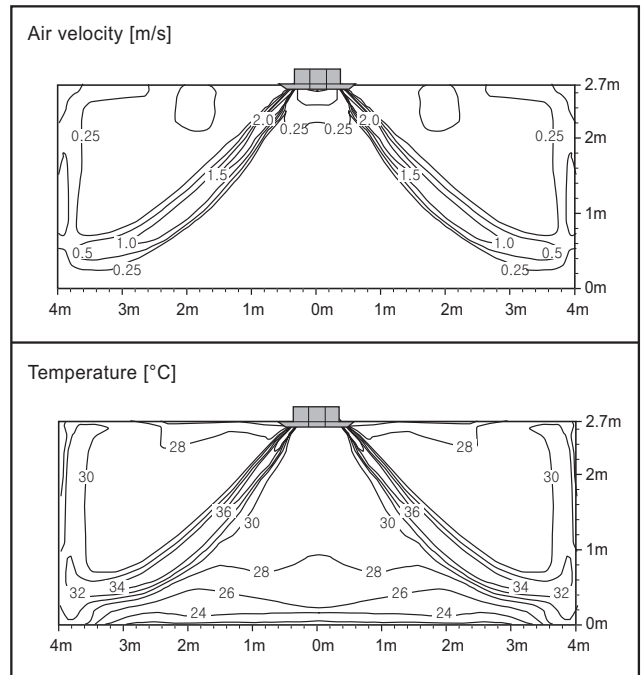

◆ WF4A072CG0B

Cooling

Discharge angle: Outer - 30°, Inner - 67°

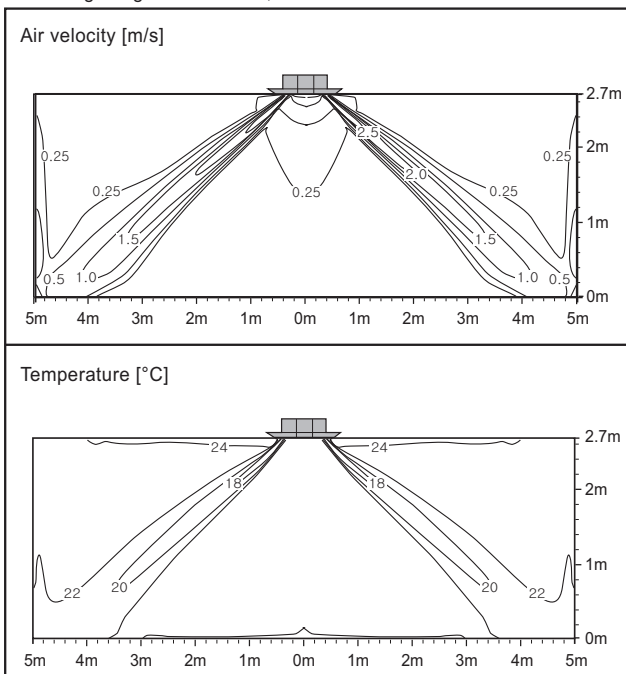

Heating

Discharge angle: Outer - 36°, Inner - 70°

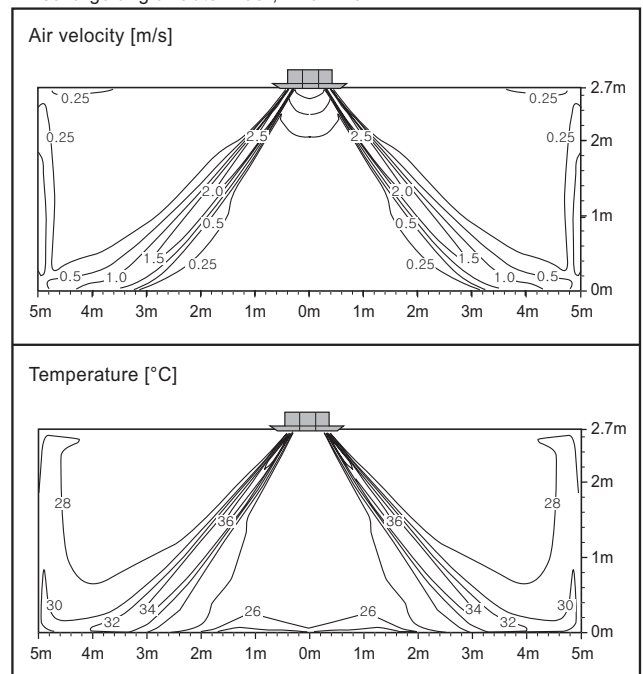

Note

- These figures are accordance with normal certain condition and environment. (Airflow step is 'High', Air discharge angle is fixed as indicated angle.)
- Indoor airflow distribution under actual installation or operating conditions depends on ambient temperature, ceiling height, product installation direction / location, indoor / Heating load, and other obstacles, etc.

7. Air Velocity and Temperature Distribution(Reference Data)

◆ WF4A090CG0B

Cooling

Discharge angle: Outer - 30°, Inner - 67°

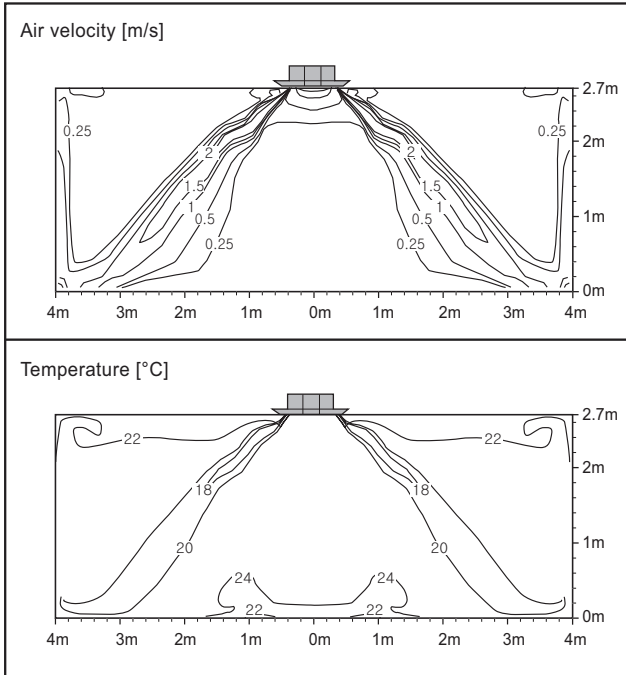

Heating

Discharge angle: Outer - 36°, Inner - 70°

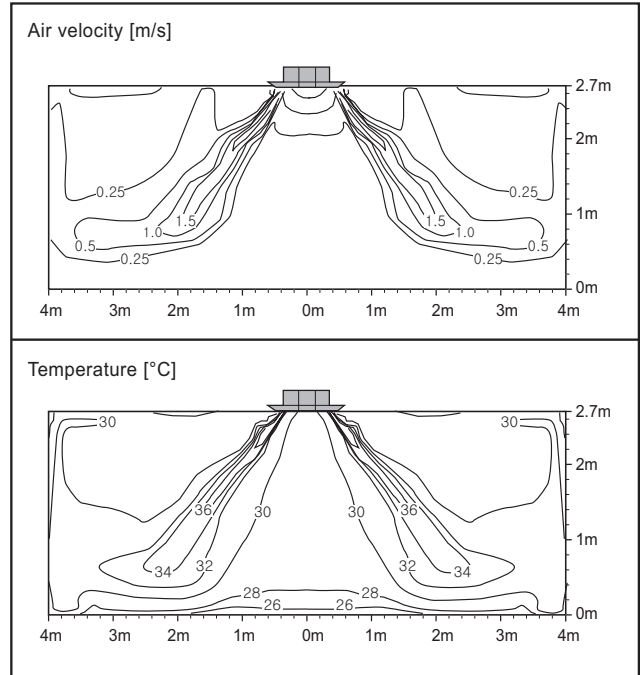

◆ WF4A105CG0B

Cooling

Discharge angle: Outer - 30°, Inner - 67°

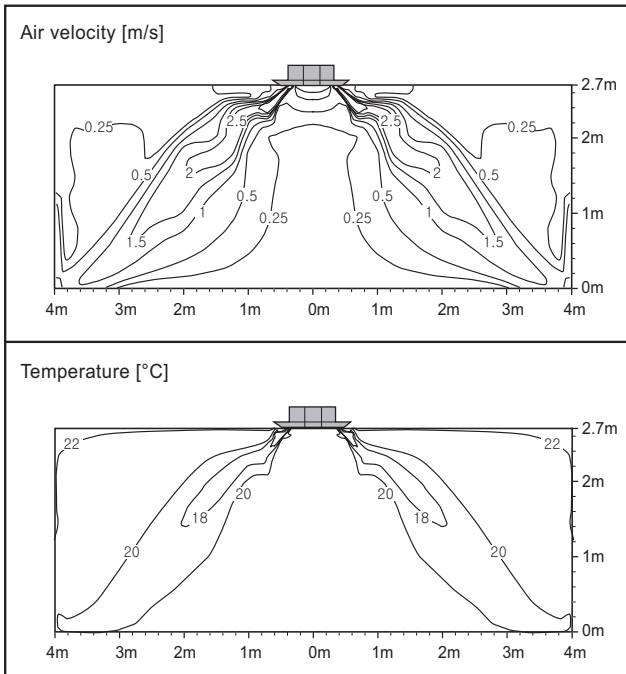

Heating

Discharge angle: Outer - 36°, Inner - 70°

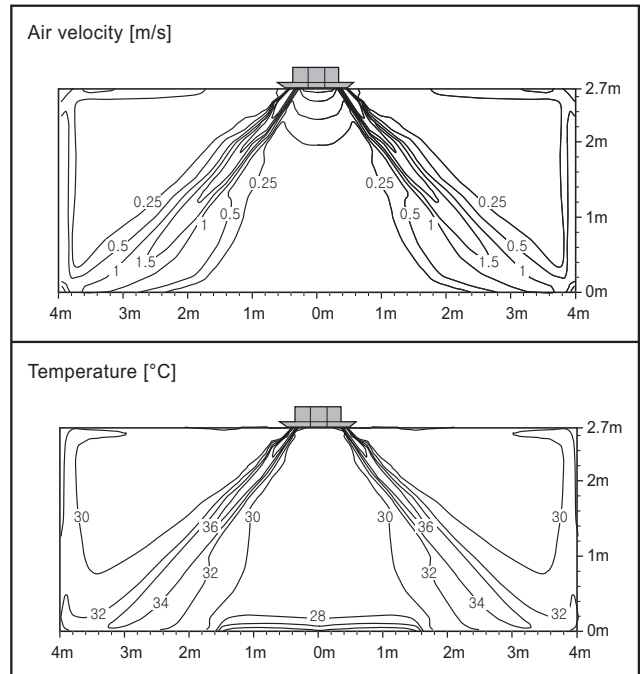

Note

- These figures are accordance with normal certain condition and environment. (Airflow step is 'High', Air discharge angle is fixed as indicated angle.)
- Indoor airflow distribution under actual installation or operating conditions depends on ambient temperature, ceiling height, product installation direction / location, indoor / Heating load, and other obstacles, etc.

7. Air Velocity and Temperature Distribution(Reference Data)

◆ WF4A130CG0B

Cooling

Discharge angle: Outer - 30°, Inner - 67°

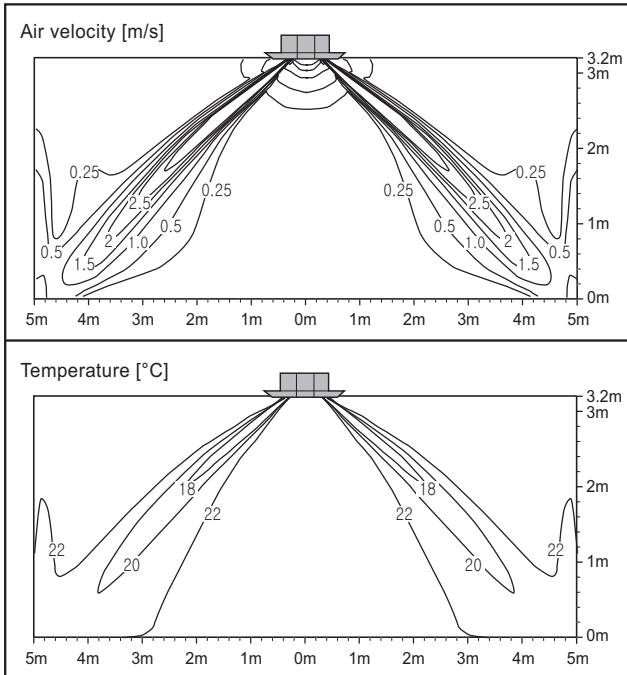

Heating

Discharge angle: Outer - 36°, Inner - 70°

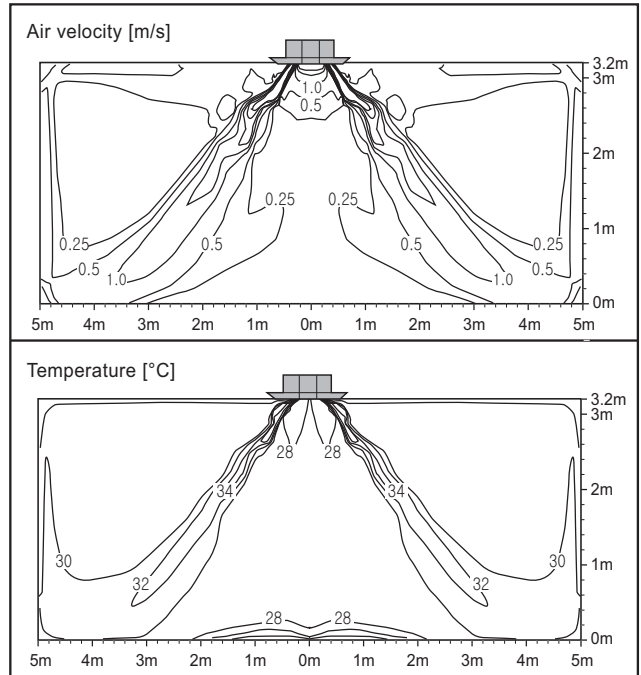

Note

- These figures are accordance with normal certain condition and environment. (Airflow step is 'High', Air discharge angle is fixed as indicated angle.)
- Indoor airflow distribution under actual installation or operating conditions depends on ambient temperature, ceiling height, product installation direction / location, indoor / Heating load, and other obstacles, etc.

8. Electric Characteristics

Unit					Power Supply	IFM		PI	
Model	Type	Hz	Volts	Voltage Range	MCA	kW	FLA	cooling	Heating
WF4A060CG0B	TP-B	60	220	Max. : 242 Min. : 198	0.38	0.050	0.30	31	31
WF4A072CG0B	TP-B				0.66	0.050	0.53	61	61
WF4A090CG0B	TM-A				0.45	0.146	0.36	39	39
WF4A105CG0B	TM-A				0.66	0.146	0.53	60	60
WF4A130CG0B	TM-A				1.15	0.146	0.92	115	115
WF4A060CG0B	TP-B	50	220-240	Max. : 264 Min. : 198	0.38	0.050	0.30	31	31
WF4A072CG0B	TP-B				0.66	0.050	0.53	61	61
WF4A090CG0B	TM-A				0.45	0.146	0.36	39	39
WF4A105CG0B	TM-A				0.66	0.146	0.53	60	60
WF4A130CG0B	TM-A				1.15	0.146	0.92	115	115
Symbols				Note					
<p>MCA : Minimum Circuit Amperes (A) kW : Fan Motor Rated Output (kW) FLA : Full Load Amperes (A) IFM : Indoor Fan Motor PI : Maximum Power Input (W)</p>				<p>1. Voltage range Units are suitable for use on electrical systems where voltage supplied to unit terminals is not below or above the listed range limits. 2. Maximum allowable voltage unbalance between phases is 2%. 3. MCA/MFA MCA=1.25 x FLA MFA = 1.1 x MCA, MFA ≤ 4 x FLA (If MFA is smaller than minimum standard value, Use minimum standard value in region for selecting circuit breaker.) 4. Select wire size based on the MCA 5. Instead of fuse, use Circuit Breaker.</p>					

9. Sound Levels

9.1 Sound Pressure Levels

Overall

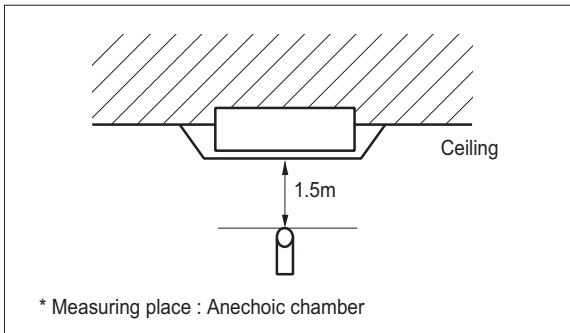

Note

1. Sound measured at some distance away from the center of the unit.
2. Data is valid at free field condition.
3. Reference acoustic pressure 0dB = 20μPa.
4. Data is valid at nominal operation condition.
Refer to the Model Specifications for nominal conditions(Power source and Ambient temperature, etc)
5. Sound levels can be increased in accordance with installation and operating conditions. (Static pressure mode, used air guide, Room target temperature setting, etc)
6. Sound level will vary depending on a range of factors such as the construction(acoustic absorption coefficient) of particular room in which the equipment is installed.
7. Sound pressure level is measured on the rated condition in the anechoic rooms by ISO 3745 standard.
Therefore, these values can be increased owing to ambient conditions during operation.

Model	Sound, Pressure, Levels, [dB(A)]		
	H	M	L
WF4A060CG0B	38	36	33
WF4A072CG0B	45	43	41
WF4A090CG0B	37	35	31
WF4A105CG0B	42	40	37
WF4A130CG0B	48	47	43

WF4A060CG0B

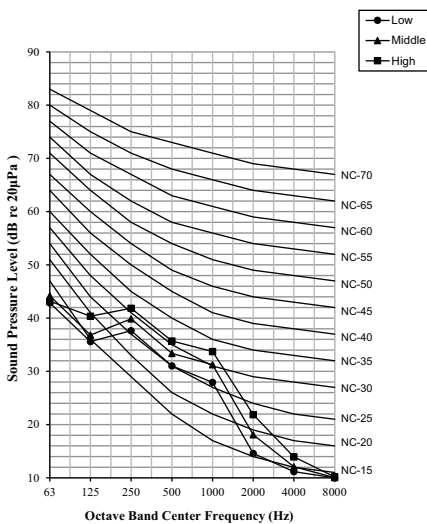

WF4A072CG0B

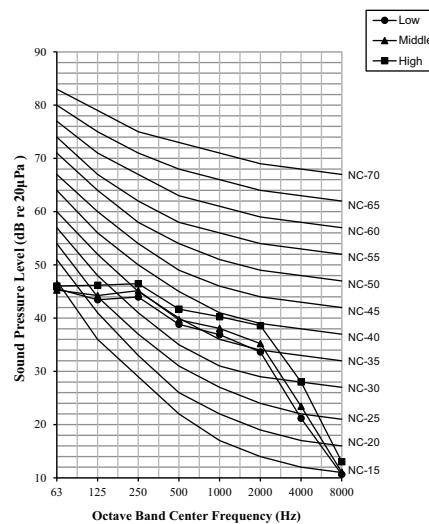

WF4A090CG0B

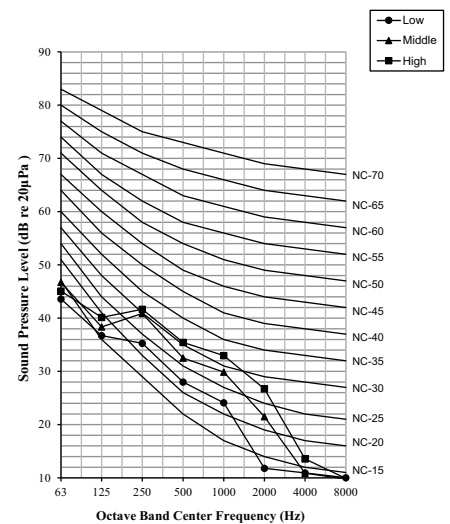

9. Sound Levels

WF4A105CG0B

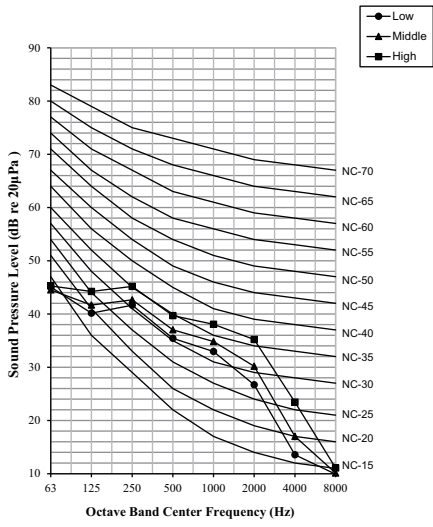

WF4A130CG0B

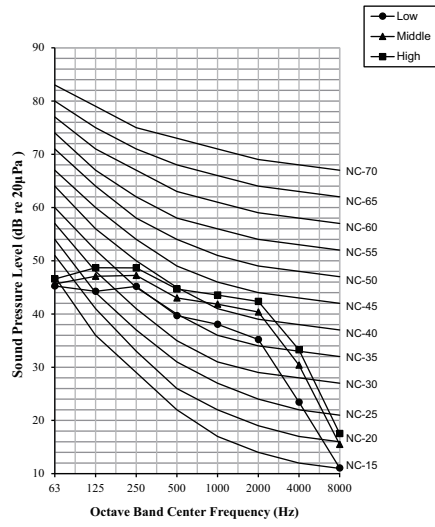

FCU

Ceiling Concealed Duct (Middle Static)

- 1. List of functions**
- 2. Specifications**
- 3. Dimensions**
- 4. Piping Diagrams**
- 5. Wiring Diagrams**
- 6. Capacity Tables**
- 7. External Static Pressure**
- 8. Electric Characteristics**
- 9. Sound Levels**

1. List of Functions

◆ List of Functions

Category		WFCB056LG0A, WFCB056RG0A, WFCB066LG0A, WFCB066RG0A, WFCB090LG0A, WFCB090RG0A, WFCB100LG0A, WFCB100RG0A, WFCB109LG0A, WFCB109RG0A, WFCB127LG0A, WFCB127RG0A, WFCB140LG0A, WFCB140RG0A
Air flow	Air supply outlet	1
	Airflow steps(fan/cool/heat)	3 / 3 / 3
	Fan Speed Auto*	-
	Power Cool/Heat	-
	Dry Operation	X
Air purification	Pre-Filter	O
	Air Purify	X
	UVnano	Accessory
Reliability	Hot start	O
	Self diagnosis	O
Convenience	Filter Check Alarm	O
	Filter Auto Check	X
	Auto Mode	X
	Auto Dry Operation**	X
	Auto Restart	O
	Child Lock*	O
	Group control*	O
	Sleep Timer**	O
	Turn On/Off Reservation**	O
	Schedule**	O
	Two Thermistor Control*	O
	Time Limit Control (Energy saving)***	O
	Temperature Setback Timer (Energy saving)***	O
External On/Off	O	
Installation	Drain pump	O
	E.S.P Setting*	O
	Auto E.S.P. Setting*	X
	High ceiling operation*	-
	Duty Rotation / Back up Operation***	X
Water Product functions	Cold And Hot Water Valve Control (ON/OFF, AC 220 V)	O
	Cold And Hot Water Valve Control (Proportional Control, DC 0~10 V)	X
	Freeze Protection Control	O
Special Functions	Wi-Fi Control	O
	Comfort Cooling (Humidity Control)	X

Note

- O : Applied, X : Not Applied, - : Unconfirmed or irrelevant
Embedded : A kit is provided by default for using this function when the product is manufactured.
Accessory : Ordered and purchased separately the accessory package referring to the model name provided and install at field. Accessory line-ups varies by region, so check your local catalogue or local sales material.
- Some functions can be limited by remote controller.
- Selecting a wireless remote controller in case of ducted type indoor units requires either a connection to the wired remote controller (Standard II) or an IR receiver accessory to be connected to the duct in order to receive the signal.
- 'Auto Mode' varies depending on the outdoor unit type.
 - Auto Change Over(Heat Recovery Outdoor Unit)
 - Auto Mode Select(Heat Pump Outdoor Unit)
 - Auto Intensity Control(Cooling Only Outdoor Unit)
- * : These functions need to connect the wired remote controller.
- ** : These functions need to connect to the Standard II / III wired remote controller.
- *** : These functions need to connect to the Standard III wired remote controller.

1. List of Functions

◆ Accessory Compatibility List

Category		Product	Remark	WFCB056LG0A, WFCB056RG0A, WFCB066LG0A, WFCB066RG0A, WFCB090LG0A, WFCB090RG0A, WFCB100LG0A, WFCB100RG0A, WFCB109LG0A, WFCB109RG0A, WFCB127LG0A, WFCB127RG0A, WFCB140LG0A, WFCB140RG0A
Wireless Remote Controller		PQWRH(C)Q0FDB	-	O
Wired Remote Controller	Simple	PQRCVCL0Q(W)	Simple	O
		PQRCHCA0Q(W)	for Hotel	O
	Standard	PREMTB001	Standard (White)	O
		PREMTBB01	Standard (Black)	O
		PREMTB100**	New Standard (White)	O
		PREMTBB10**	New Standard (Black)	O
Premium	PREMTA000(A/B)	Premium	O	
Dry contact	Simple Contact	PDRYCB000	Simple Dry Contact	O
	Communication type	PDRYCB400	Points Dry Contact (For Setback)	O
		PDRYCB300	Dry Contact For 3rd Party Thermostat	O
		PDRYCB500	Dry Contact For Modbus	O
Gateway	IDU PI485	PHNFP14A0	Connected with the Indoor Units	-
		PSNFP14A0	Connected with the Indoor Units	-
ETC	Remote temperature sensor	PQRSTA0	-	O
	Zone controller	ABZCA	-	-
	CO2 Sensor	PES-C0RV0	-	-
	Group control wire	PZCWRCG3	0.25m	O
	2-Remo Control Wire	PZCWRC2	0.25m	O
	Extension Wire	PZCWRC1	10m	O
	Wi-Fi Controller*	PWFMD200	-	O
	Independent Power Module	PRIP0	-	X
	Multi-tenant Power Module	PINPMB001	-	X
	Human Detecting Controller	PHD-TM0	-	-
	UVnano Filter Box	PBM13M1UA0	For M1 Chassis	O
		PBM13M2UA0	For M2 Chassis	O
		PBM13M3UA0	For M3Chassis	O
	High Efficiency Filter (Main Filter of Filter Box)	FBM13M1UA0	For M1 UVnano Filter Box	O
FBM13M2UA0		For M2 UVnano Filter Box	O	
FBM13M3UA0		For M3 UVnano Filter Box	O	

Note

- O: Possible, X: Impossible, -: Not applicable, Embedded: Included with product.
- *: Some advanced functions controlled by individual controller cannot be operated.
- ** : It could not be operated some functions.
- If you need more detail, please refer to the **BECON** PDB or the manual of product. (<http://partner.lge.com> > Select Your Region : Home> Doc.Library> Product > Control(BECON))

2. Specifications

Type			Ceiling Concealed Duct - MiddleStatic	
Model Name		Unit	WFCB056LG0A	WFCB056RG0A
Power Supply	Rated Power Supply	V, Φ , Hz	220-230-240, 1, 50	220-230-240, 1, 50
	Limit Range of Voltage	V	198 ~ 264	198 ~ 264
Running Current by Voltage		A	0.72 - 0.69 - 0.66	0.72 - 0.69 - 0.66
Capacity	Cooling	Condition A	5.6 (4,815)	5.6 (4,815)
		Condition B	4.2 (3,611)	4.2 (3,611)
		Condition C	4.8 (4,127)	4.8 (4,127)
		Condition D	2.7 (2,322)	2.7 (2,322)
	Heating	Condition A	6.5 (5,589)	6.5 (5,589)
		Condition B	8.0 (6,879)	8.0 (6,879)
Water Flow Rate	Cooling	Condition A	16.3	16.3
		Condition B	12.5	12.5
		Condition C	14.0	14.0
		Condition D	10.0	10.0
	Heating	Condition A	19.0	19.0
		Condition B	16.3	16.3
Head Loss	Cooling	Condition A	14.6	14.6
		Condition B	7.6	7.6
		Condition C	9.4	9.4
		Condition D	4.9	4.9
	Heating	Condition A	20.3	20.3
		Condition B	14.6	14.6
Power Input	H/M/L	W	102 / 72 / 57	102 / 72 / 57
Running Current	H/M/L	A	0.69 / 0.49 / 0.39	0.69 / 0.49 / 0.39
Fan	Type	-	Sirocco Fan	Sirocco Fan
	Air Flow Rate(H/M/L)	m ³ /min	15.0 / 12.0 / 10.0	15.0 / 12.0 / 10.0
	External Static Pressure (Factory Set)	mmAq	6	6
	External Static Pressure Range	mmAq	2.5 ~ 15	2.5 ~ 15
Fan Motor	Type	-	BLDC	BLDC
	Drive	-	Direct	Direct
	Output	W x No.	136.49 × 1	136.49 × 1
Dimensions	Net (W x H x D)	mm	900 × 270 × 700	900 × 270 × 700
	Shipping (W x H x D)	mm	1,100 × 338 × 773	1,100 × 338 × 773
Weight	Net	kg	28.4	27.9
	Shipping	kg	33.5	33.0
Air Filter	Type	-	Long life	Long life
Temperature Control		-	Microprocessor, Thermostat for cooling and heating	
Sound Absorbing / Thermal Insulation Material		-	Foamed polystyrene	Foamed polystyrene
Protection Device		-	Fuse	Fuse
Water Connecting Pipes	Inlet	-	BSPF G 3/4"(male)	BSPF G 3/4"(male)
	Outlet	-	BSPF G 3/4"(male)	BSPF G 3/4"(male)
Drain Pipe (Natural Drainage)	O.D / I.D	mm	-	-
Drain Pipe (using Drain Pump)	O.D / I.D	mm	Ø 32.0 / 25.0	Ø 32.0 / 25.0
Sound Pressure Level	H/M/L	dB(A)	43.0 / 41.0 / 39.0	43.0 / 41.0 / 39.0
Sound Power Level	H/M/L	dB(A)	61.0 / 58.0 / 57.0	61.0 / 58.0 / 57.0
Connecting Cable	Communication Cable (VCTF-SB)	mm ² ×cores	1.0~1.5 × 2C	1.0~1.5 × 2C

Note

- Due to our policy of innovation some specifications may be changed without notification.
- Wiring cable size must comply with the applicable local and national codes. And "Electric characteristics" chapter should be considered for electrical work and design. Especially the power cable and circuit breaker should be selected in accordance with that.
- Sound Level Values are measured at Noise Measuring chamber accordance with standard. Therefore, these values depend on the ambient conditions and values are normally higher in actual operation.
- Performances are based on the following conditions :
 - Cooling
 - Condition A : Inlet/Outlet Water Temp. 7°C / 12°C, Indoor Air Temp. 27°CDB / 19°CWB
 - Condition B : Inlet/Outlet Water Temp. 10°C / 15°C, Indoor Air Temp. 27°CDB / 19°CWB
 - Condition C : Inlet/Outlet Water Temp. 7°C / 12°C, Indoor Air Temp. 25°CDB / 17.9°CWB
 - Condition D : Inlet/Outlet Water Temp. 14°C / 18°C, Indoor Air Temp. 26°CDB / 18°CWB
 - Heating
 - Condition A : Inlet/Outlet Water Temp. 45°C / 40°C, Indoor Air Temp. 20°CDB / 15°CWB
 - Condition B : Inlet Water Temp. 50°C, Indoor Air Temp. 20°CDB / 15°CWB
- Capacity, power consumption, etc. may vary depending on the product installation conditions (temperature, conditions of use).
- Main power line should be shorter than 50m. When installing a power line longer than 50m, contact LG Electronics.

2. Specifications

Type			Ceiling Concealed Duct - MiddleStatic	
Model Name		Unit	WFCB066LG0A	WFCB066RG0A
Power Supply	Rated Power Supply	V, Φ , Hz	220-230-240, 1, 50	220-230-240, 1, 50
	Limit Range of Voltage	V	198 ~ 264	198 ~ 264
Running Current by Voltage		A	1.00 - 0.96 - 0.92	1.00 - 0.96 - 0.92
Capacity	Cooling	Condition A	6.6 (5,675)	6.6 (5,675)
		Condition B	4.9 (4,213)	4.9 (4,213)
		Condition C	5.8 (4,987)	5.8 (4,987)
		Condition D	3.3 (2,837)	3.3 (2,837)
	Heating	Condition A	7.8 (6,707)	7.8 (6,707)
		Condition B	9.2 (7,911)	9.2 (7,911)
Water Flow Rate	Cooling	Condition A	19.7	19.7
		Condition B	14.5	14.5
		Condition C	17.0	17.0
		Condition D	12.0	12.0
	Heating	Condition A	23.0	23.0
		Condition B	19.7	19.7
Head Loss	Cooling	Condition A	22.7	22.7
		Condition B	10.2	10.2
		Condition C	13.9	13.9
		Condition D	7.0	7.0
	Heating	Condition A	28.1	28.1
		Condition B	22.7	22.7
Power Input	H/M/L	W	143 / 98 / 72	143 / 98 / 72
Running Current	H/M/L	A	0.96 / 0.67 / 0.49	0.96 / 0.67 / 0.49
Fan	Type	-	Sirocco Fan	Sirocco Fan
	Air Flow Rate(H/M/L)	m ³ /min	18.0 / 15.0 / 12.0	18.0 / 15.0 / 12.0
	External Static Pressure (Factory Set)	mmAq	6	6
	External Static Pressure Range	mmAq	5 ~ 15	5 ~ 15
Fan Motor	Type	-	BLDC	BLDC
	Drive	-	Direct	Direct
	Output	W x No.	136.49 x 1	136.49 x 1
Dimensions	Net (W x H x D)	mm	900 x 270 x 700	900 x 270 x 700
	Shipping (W x H x D)	mm	1,100 x 338 x 773	1,100 x 338 x 773
Weight	Net	kg	28.4	27.9
	Shipping	kg	33.5	33.0
Air Filter	Type	-	Long life	Long life
Temperature Control		-	Microprocessor, Thermostat for cooling and heating	
Sound Absorbing / Thermal Insulation Material		-	Foamed polystyrene	Foamed polystyrene
Protection Device		-	Fuse	Fuse
Water Connecting Pipes	Inlet	-	BSPF G 3/4"(male)	BSPF G 3/4"(male)
	Outlet	-	BSPF G 3/4"(male)	BSPF G 3/4"(male)
Drain Pipe (Natural Drainage)	O.D / I.D	mm	-	-
Drain Pipe (using Drain Pump)	O.D / I.D	mm	Ø 32.0 / 25.0	Ø 32.0 / 25.0
Sound Pressure Level	H/M/L	dB(A)	45.0 / 43.0 / 41.0	45.0 / 43.0 / 41.0
Sound Power Level	H/M/L	dB(A)	63.0 / 61.0 / 58.0	63.0 / 61.0 / 58.0
Connecting Cable	Communication Cable (VCTF-SB)	mm ² xcores	1.0~1.5 x 2C	1.0~1.5 x 2C

Note

- Due to our policy of innovation some specifications may be changed without notification.
- Wiring cable size must comply with the applicable local and national codes. And "Electric characteristics" chapter should be considered for electrical work and design. Especially the power cable and circuit breaker should be selected in accordance with that.
- Sound Level Values are measured at Noise Measuring chamber accordance with standard. Therefore, these values depend on the ambient conditions and values are normally higher in actual operation.
- Performances are based on the following conditions :
 - Cooling
 - Condition A : Inlet/Outlet Water Temp. 7°C / 12°C, Indoor Air Temp. 27°CDB / 19°CWB
 - Condition B : Inlet/Outlet Water Temp. 10°C / 15°C, Indoor Air Temp. 27°CDB / 19°CWB
 - Condition C : Inlet/Outlet Water Temp. 7°C / 12°C, Indoor Air Temp. 25°CDB / 17.9°CWB
 - Condition D : Inlet/Outlet Water Temp. 14°C / 18°C, Indoor Air Temp. 26°CDB / 18°CWB
 - Heating
 - Condition A : Inlet/Outlet Water Temp. 45°C / 40°C, Indoor Air Temp. 20°CDB / 15°CWB
 - Condition B : Inlet Water Temp. 50°C, Indoor Air Temp. 20°CDB / 15°CWB
- Capacity, power consumption, etc. may vary depending on the product installation conditions (temperature, conditions of use).
- Main power line should be shorter than 50m. When installing a power line longer than 50m, contact LG Electronics.

2. Specifications

Type		Ceiling Concealed Duct - MiddleStatic		
Model Name		Unit	WFCB090LG0A	WFCB090RG0A
Power Supply	Rated Power Supply	V, Φ , Hz	220-230-240, 1, 50	220-230-240, 1, 50
	Limit Range of Voltage	V	198 ~ 264	198 ~ 264
Running Current by Voltage		A	0.96 - 0.92 - 0.88	0.96 - 0.92 - 0.88
Capacity	Cooling	Condition A	9.0 (7,739)	9.0 (7,739)
		Condition B	6.8 (5,847)	6.8 (5,847)
		Condition C	8.0 (6,879)	8.0 (6,879)
		Condition D	4.3 (3,697)	4.3 (3,697)
	Heating	Condition A	10.9 (9,372)	10.9 (9,372)
		Condition B	12.5 (10,748)	12.5 (10,748)
Water Flow Rate	Cooling	Condition A	25.2	25.2
		Condition B	20.0	20.0
		Condition C	23.5	23.5
		Condition D	16.0	16.0
	Heating	Condition A	32.0	32.0
		Condition B	25.2	25.2
Head Loss	Cooling	Condition A	24.5	24.5
		Condition B	14.4	14.4
		Condition C	19.7	19.7
		Condition D	8.7	8.7
	Heating	Condition A	10.7	10.7
		Condition B	24.5	24.5
Power Input	H/M/L	W	136 / 105 / 84	136 / 105 / 84
Running Current	H/M/L	A	0.92 / 0.72 / 0.58	0.92 / 0.72 / 0.58
Fan	Type	-	Sirocco Fan	Sirocco Fan
	Air Flow Rate(H/M/L)	m ³ /min	25.0 / 20.0 / 16.0	25.0 / 20.0 / 16.0
	External Static Pressure (Factory Set)	mmAq	6	6
	External Static Pressure Range	mmAq	5 ~ 15	5 ~ 15
Fan Motor	Type	-	BLDC	BLDC
	Drive	-	Direct	Direct
	Output	W x No.	350 x 1	350 x 1
Dimensions	Net (W x H x D)	mm	1,250 x 270 x 700	1,250 x 270 x 700
	Shipping (W x H x D)	mm	1,450 x 338 x 773	1,450 x 338 x 773
Weight	Net	kg	41.0	40.6
	Shipping	kg	46.9	46.9
Air Filter	Type	-	Long life	Long life
Temperature Control		-	Microprocessor, Thermostat for cooling and heating	
Sound Absorbing / Thermal Insulation Material		-	Foamed polystrene	Foamed polystrene
Protection Device		-	Fuse	Fuse
Water Connecting Pipes	Inlet	-	BSPF G 3/4"(male)	BSPF G 3/4"(male)
	Outlet	-	BSPF G 3/4"(male)	BSPF G 3/4"(male)
Drain Pipe (Natural Drainage)	O.D / I.D	mm	-	-
Drain Pipe (using Drain Pump)	O.D / I.D	mm	Ø 32.0 / 25.0	Ø 32.0 / 25.0
Sound Pressure Level	H/M/L	dB(A)	46.0 / 44.0 / 43.0	46.0 / 44.0 / 43.0
Sound Power Level	H/M/L	dB(A)	59.0 / 58.0 / 57.0	59.0 / 58.0 / 57.0
Connecting Cable	Communication Cable (VCTF-SB)	mm ² ×cores	1.0~1.5 × 2C	1.0~1.5 × 2C

Note

- Due to our policy of innovation some specifications may be changed without notification.
- Wiring cable size must comply with the applicable local and national codes. And "Electric characteristics" chapter should be considered for electrical work and design. Especially the power cable and circuit breaker should be selected in accordance with that.
- Sound Level Values are measured at Noise Measuring chamber accordance with standard. Therefore, these values depend on the ambient conditions and values are normally higher in actual operation.
- Performances are based on the following conditions :
 - Cooling
 - Condition A : Inlet/Outlet Water Temp. 7°C / 12°C, Indoor Air Temp. 27°CDB / 19°CWB
 - Condition B : Inlet/Outlet Water Temp. 10°C / 15°C, Indoor Air Temp. 27°CDB / 19°CWB
 - Condition C : Inlet/Outlet Water Temp. 7°C / 12°C, Indoor Air Temp. 25°CDB / 17.9°CWB
 - Condition D : Inlet/Outlet Water Temp. 14°C / 18°C, Indoor Air Temp. 26°CDB / 18°CWB
 - Heating
 - Condition A : Inlet/Outlet Water Temp. 45°C / 40°C, Indoor Air Temp. 20°CDB / 15°CWB
 - Condition B : Inlet Water Temp. 50°C, Indoor Air Temp. 20°CDB / 15°CWB
- Capacity, power consumption, etc. may vary depending on the product installation conditions (temperature, conditions of use).
- Main power line should be shorter than 50m. When installing a power line longer than 50m, contact LG Electronics.

2. Specifications

Type		Ceiling Concealed Duct - MiddleStatic		
		Model Name	Unit	WFCB100LG0A
Power Supply	Rated Power Supply	V, Φ, Hz	220-230-240, 1, 50	220-230-240, 1, 50
	Limit Range of Voltage	V	198 ~ 264	198 ~ 264
Running Current by Voltage		A	1.32 - 1.26 - 1.21	1.32 - 1.26 - 1.21
Capacity	Cooling	Condition A	10.0 (8,598)	10.0 (8,598)
		Condition B	7.8 (6,707)	7.8 (6,707)
		Condition C	9.2 (7,911)	9.2 (7,911)
		Condition D	5.0 (4,299)	5.0 (4,299)
	Heating	Condition A	12.6 (10,834)	12.6 (10,834)
		Condition B	14.6 (12,554)	14.6 (12,554)
Water Flow Rate	Cooling	Condition A	29.9	29.9
		Condition B	23.0	23.0
		Condition C	27.0	27.0
		Condition D	18.5	18.5
	Heating	Condition A	37.0	37.0
		Condition B	29.9	29.9
Head Loss	Cooling	Condition A	33.7	33.7
		Condition B	19.1	19.1
		Condition C	26.0	26.0
		Condition D	11.8	11.8
	Heating	Condition A	14.1	14.1
		Condition B	33.7	33.7
Power Input	H/M/L	W	189 / 143 / 106	189 / 143 / 106
Running Current	H/M/L	A	1.26 / 0.96 / 0.72	1.26 / 0.96 / 0.72
Fan	Type	-	Sirocco Fan	Sirocco Fan
	Air Flow Rate(H/M/L)	m³/min	30.0 / 25.0 / 20.0	30.0 / 25.0 / 20.0
	External Static Pressure (Factory Set)	mmAq	6	6
	External Static Pressure Range	mmAq	5 ~ 15	5 ~ 15
Fan Motor	Type	-	BLDC	BLDC
	Drive	-	Direct	Direct
	Output	W x No.	350 × 1	350 × 1
Dimensions	Net (W x H x D)	mm	1,250 × 270 × 700	1,250 × 270 × 700
	Shipping (W x H x D)	mm	1,450 × 338 × 773	1,450 × 338 × 773
Weight	Net	kg	41.0	40.6
	Shipping	kg	46.9	46.9
Air Filter	Type	-	Long life	Long life
Temperature Control		-	Microprocessor, Thermostat for cooling and heating	
Sound Absorbing / Thermal Insulation Material		-	Foamed polystrene	Foamed polystrene
Protection Device		-	Fuse	Fuse
Water Connecting Pipes	Inlet	-	BSPF G 3/4"(male)	BSPF G 3/4"(male)
	Outlet	-	BSPF G 3/4"(male)	BSPF G 3/4"(male)
Drain Pipe (Natural Drainage)	O.D / I.D	mm	-	-
Drain Pipe (using Drain Pump)	O.D / I.D	mm	Ø 32.0 / 25.0	Ø 32.0 / 25.0
Sound Pressure Level	H/M/L	dB(A)	47.0 / 46.0 / 44.0	47.0 / 46.0 / 44.0
Sound Power Level	H/M/L	dB(A)	61.0 / 59.0 / 58.0	61.0 / 59.0 / 58.0
Connecting Cable	Communication Cable (VCTF-SB)	mm²×cores	1.0~1.5 × 2C	1.0~1.5 × 2C

Note

- Due to our policy of innovation some specifications may be changed without notification.
- Wiring cable size must comply with the applicable local and national codes. And "Electric characteristics" chapter should be considered for electrical work and design. Especially the power cable and circuit breaker should be selected in accordance with that.
- Sound Level Values are measured at Noise Measuring chamber accordance with standard. Therefore, these values depend on the ambient conditions and values are normally higher in actual operation.
- Performances are based on the following conditions :
 - Cooling
 - Condition A : Inlet/Outlet Water Temp. 7°C / 12°C, Indoor Air Temp. 27°CDB / 19°CWB
 - Condition B : Inlet/Outlet Water Temp. 10°C / 15°C, Indoor Air Temp. 27°CDB / 19°CWB
 - Condition C : Inlet/Outlet Water Temp. 7°C / 12°C, Indoor Air Temp. 25°CDB / 17.9°CWB
 - Condition D : Inlet/Outlet Water Temp. 14°C / 18°C, Indoor Air Temp. 26°CDB / 18°CWB
 - Heating
 - Condition A : Inlet/Outlet Water Temp. 45°C / 40°C, Indoor Air Temp. 20°CDB / 15°CWB
 - Condition B : Inlet Water Temp. 50°C, Indoor Air Temp. 20°CDB / 15°CWB
- Capacity, power consumption, etc. may vary depending on the product installation conditions (temperature, conditions of use).
- Main power line should be shorter than 50m. When installing a power line longer than 50m, contact LG Electronics.

2. Specifications

Type			Ceiling Concealed Duct - MiddleStatic	
Model Name		Unit	WFCB109LG0A	WFCB109RG0A
Power Supply	Rated Power Supply	V, Φ, Hz	220-230-240, 1, 50	220-230-240, 1, 50
	Limit Range of Voltage	V	198 ~ 264	198 ~ 264
Running Current by Voltage		A	1.60 - 1.53 - 1.47	1.60 - 1.53 - 1.47
Capacity	Cooling	Condition A	10.9 (9,372)	10.9 (9,372)
		Condition B	8.7 (7,481)	8.7 (7,481)
		Condition C	10.0 (8,598)	10.0 (8,598)
		Condition D	5.6 (4,815)	5.6 (4,815)
	Heating	Condition A	14.0 (12,038)	14.0 (12,038)
		Condition B	14.9 (12,812)	14.9 (12,812)
Water Flow Rate	Cooling	Condition A	30.9	30.9
		Condition B	25.5	25.5
		Condition C	29.5	29.5
		Condition D	20.5	20.5
	Heating	Condition A	41.0	41.0
		Condition B	30.9	30.9
Head Loss	Cooling	Condition A	37.8	37.8
		Condition B	23.5	23.5
		Condition C	31.1	31.1
		Condition D	14.5	14.5
	Heating	Condition A	16.9	16.9
		Condition B	37.8	37.8
Power Input	H/M/L	W	233 / 197 / 143	233 / 197 / 143
Running Current	H/M/L	A	1.53 / 1.31 / 0.96	1.53 / 1.31 / 0.96
Fan	Type	-	Sirocco Fan	Sirocco Fan
	Air Flow Rate(H/M/L)	m ³ /min	34.0 / 30.0 / 25.0	34.0 / 30.0 / 25.0
	External Static Pressure (Factory Set)	mmAq	6	6
	External Static Pressure Range	mmAq	5 ~ 15	5 ~ 15
Fan Motor	Type	-	BLDC	BLDC
	Drive	-	Direct	Direct
	Output	W x No.	350 × 1	350 × 1
Dimensions	Net (W x H x D)	mm	1,250 × 270 × 700	1,250 × 270 × 700
	Shipping (W x H x D)	mm	1,450 × 338 × 773	1,450 × 338 × 773
Weight	Net	kg	41.0	40.6
	Shipping	kg	46.9	46.9
Air Filter	Type	-	Long life	Long life
Temperature Control		-	Microprocessor, Thermostat for cooling and heating	
Sound Absorbing / Thermal Insulation Material		-	Foamed polystrene	Foamed polystrene
Protection Device		-	Fuse	Fuse
Water Connecting Pipes	Inlet	-	BSPF G 3/4"(male)	BSPF G 3/4"(male)
	Outlet	-	BSPF G 3/4"(male)	BSPF G 3/4"(male)
Drain Pipe (Natural Drainage)	O.D / I.D	mm	-	-
Drain Pipe (using Drain Pump)	O.D / I.D	mm	Ø 32.0 / 25.0	Ø 32.0 / 25.0
Sound Pressure Level	H/M/L	dB(A)	48.0 / 47.0 / 46.0	48.0 / 47.0 / 46.0
Sound Power Level	H/M/L	dB(A)	63.0 / 61.0 / 59.0	63.0 / 61.0 / 59.0
Connecting Cable	Communication Cable (VCTF-SB)	mm ² ×cores	1.0~1.5 × 2C	1.0~1.5 × 2C

Note

1. Due to our policy of innovation some specifications may be changed without notification.
2. Wiring cable size must comply with the applicable local and national codes. And "Electric characteristics" chapter should be considered for electrical work and design. Especially the power cable and circuit breaker should be selected in accordance with that.
3. Sound Level Values are measured at Noise Measuring chamber accordance with standard. Therefore, these values depend on the ambient conditions and values are normally higher in actual operation.
4. Performances are based on the following conditions :
 - 1) Cooling
 - Inlet/Outlet Water Temp. 7°C / 12°C, Indoor Air Temp. 27°CDB / 19°CWB
 - 2) Heating
 - Inlet Water Temp. 60°C, Indoor Air Temp. 20°CDB / 15°CWB
5. Capacity, power consumption, etc. may vary depending on the product installation conditions (temperature, conditions of use).
6. Main power line should be shorter than 50m. When installing a power line longer than 50m, contact LG Electronics.
7. Water connecting pipes are in accordance with the DIN-EN-ISO 228-1 standard.

2. Specifications

Type		Ceiling Concealed Duct - MiddleStatic		
		Model Name	Unit	WFCB127LG0A
Power Supply	Rated Power Supply	V, Φ, Hz	220-230-240, 1, 50	220-230-240, 1, 50
	Limit Range of Voltage	V	198 ~ 264	198 ~ 264
Running Current by Voltage		A	1.36 - 1.30 - 1.25	1.36 - 1.30 - 1.25
Capacity	Cooling	Condition A	12.7 (10,920)	12.7 (10,920)
		Condition B	9.3 (7,997)	9.3 (7,997)
		Condition C	11.4 (9,802)	11.4 (9,802)
		Condition D	6.4 (5,503)	6.4 (5,503)
	Heating	Condition A	15.3 (13,156)	15.3 (13,156)
		Condition B	16.8 (14,445)	16.8 (14,445)
Water Flow Rate	Cooling	Condition A	35.3	35.3
		Condition B	27.5	27.5
		Condition C	33.5	33.5
		Condition D	23.5	23.5
	Heating	Condition A	45.0	45.0
		Condition B	35.3	35.3
Head Loss	Cooling	Condition A	35.4	35.4
		Condition B	22.3	22.3
		Condition C	32.5	32.5
		Condition D	16.3	16.3
	Heating	Condition A	59.8	59.8
		Condition B	35.4	35.4
Power Input	H/M/L	W	217 / 188 / 152	217 / 188 / 152
Running Current	H/M/L	A	1.30 / 1.15 / 0.94	1.30 / 1.15 / 0.94
Fan	Type	-	Sirocco Fan	Sirocco Fan
	Air Flow Rate(H/M/L)	m ³ /min	36.0 / 32.0 / 28.0	36.0 / 32.0 / 28.0
	External Static Pressure (Factory Set)	mmAq	6	6
	External Static Pressure Range	mmAq	5 ~ 15	5 ~ 15
Fan Motor	Type	-	BLDC	BLDC
	Drive	-	Direct	Direct
	Output	W x No.	400 × 1	400 × 1
Dimensions	Net (W x H x D)	mm	1,250 x 360 x 700	1,250 x 360 x 700
	Shipping (W x H x D)	mm	1,450 x 428 x 773	1,450 x 428 x 773
Weight	Net	kg	46.0	45.5
	Shipping	kg	52.3	52.2
Air Filter	Type	-	Long life	Long life
Temperature Control		-	Microprocessor, Thermostat for cooling and heating	
Sound Absorbing / Thermal Insulation Material		-	Foamed polystrene	Foamed polystrene
Protection Device		-	Fuse	Fuse
Water Connecting Pipes	Inlet	-	BSPF G 3/4"(male)	BSPF G 3/4"(male)
	Outlet	-	BSPF G 3/4"(male)	BSPF G 3/4"(male)
Drain Pipe (Natural Drainage)	O.D / I.D	mm	-	-
Drain Pipe (using Drain Pump)	O.D / I.D	mm	Ø 32.0 / 25.0	Ø 32.0 / 25.0
Sound Pressure Level	H/M/L	dB(A)	49.0 / 48.0 / 47.0	49.0 / 48.0 / 47.0
Sound Power Level	H/M/L	dB(A)	64.0 / 63.0 / 62.0	64.0 / 63.0 / 62.0
Connecting Cable	Communication Cable (VCTF-SB)	mm ² ×cores	1.0~1.5 × 2C	1.0~1.5 × 2C

Note

- Due to our policy of innovation some specifications may be changed without notification.
- Wiring cable size must comply with the applicable local and national codes. And "Electric characteristics" chapter should be considered for electrical work and design. Especially the power cable and circuit breaker should be selected in accordance with that.
- Sound Level Values are measured at Noise Measuring chamber accordance with standard. Therefore, these values depend on the ambient conditions and values are normally higher in actual operation.
- Performances are based on the following conditions :
 - Cooling
 - Condition A : Inlet/Outlet Water Temp. 7°C / 12°C, Indoor Air Temp. 27°CDB / 19°CWB
 - Condition B : Inlet/Outlet Water Temp. 10°C / 15°C, Indoor Air Temp. 27°CDB / 19°CWB
 - Condition C : Inlet/Outlet Water Temp. 7°C / 12°C, Indoor Air Temp. 25°CDB / 17.9°CWB
 - Condition D : Inlet/Outlet Water Temp. 14°C / 18°C, Indoor Air Temp. 26°CDB / 18°CWB
 - Heating
 - Condition A : Inlet/Outlet Water Temp. 45°C / 40°C, Indoor Air Temp. 20°CDB / 15°CWB
 - Condition B : Inlet Water Temp. 50°C, Indoor Air Temp. 20°CDB / 15°CWB
- Capacity, power consumption, etc. may vary depending on the product installation conditions (temperature, conditions of use).
- Main power line should be shorter than 50m. When installing a power line longer than 50m, contact LG Electronics.

2. Specifications

Type		Ceiling Concealed Duct - MiddleStatic		
		Model Name	Unit	WFCB140LG0A
Power Supply	Rated Power Supply	V, Φ, Hz	220-230-240, 1, 50	220-230-240, 1, 50
	Limit Range of Voltage	V	198 ~ 264	198 ~ 264
Running Current by Voltage		A	1.65 - 1.58 - 1.51	1.65 - 1.58 - 1.51
Capacity	Cooling	Condition A	14.0 (12,038)	14.0 (12,038)
		Condition B	10.4 (8,942)	10.4 (8,942)
		Condition C	12.2 (10,490)	12.2 (10,490)
		Condition D	6.8 (5,847)	6.8 (5,847)
	Heating	Condition A	16.6 (14,273)	16.6 (14,273)
		Condition B	18.5 (15,907)	18.5 (15,907)
Water Flow Rate	Cooling	Condition A	40.1	40.1
		Condition B	30.5	30.5
		Condition C	36.0	36.0
		Condition D	25.0	25.0
	Heating	Condition A	49.0	49.0
		Condition B	40.1	40.1
Head Loss	Cooling	Condition A	45.4	45.4
		Condition B	27.3	27.3
		Condition C	38.3	38.3
		Condition D	18.7	18.7
	Heating	Condition A	70.7	70.7
		Condition B	45.4	45.4
Power Input	H/M/L	W	266 / 223 / 187	266 / 223 / 187
Running Current	H/M/L	A	1.58 / 1.35 / 1.15	1.58 / 1.35 / 1.15
Fan	Type	-	Sirocco Fan	Sirocco Fan
	Air Flow Rate(H/M/L)	m³/min	40.0 / 36.0 / 32.0	40.0 / 36.0 / 32.0
	External Static Pressure (Factory Set)	mmAq	6	6
	External Static Pressure Range	mmAq	5 ~ 15	5 ~ 15
Fan Motor	Type	-	BLDC	BLDC
	Drive	-	Direct	Direct
	Output	W x No.	400 × 1	400 × 1
Dimensions	Net (W x H x D)	mm	1,250 x 360 x 700	1,250 x 360 x 700
	Shipping (W x H x D)	mm	1,450 x 428 x 773	1,450 x 428 x 773
Weight	Net	kg	46.0	45.5
	Shipping	kg	52.3	52.2
Air Filter	Type	-	Long life	Long life
Temperature Control		-	Microprocessor, Thermostat for cooling and heating	
Sound Absorbing / Thermal Insulation Material		-	Foamed polystrene	Foamed polystrene
Protection Device		-	Fuse	Fuse
Water Connecting Pipes	Inlet	-	BSPF G 3/4"(male)	BSPF G 3/4"(male)
	Outlet	-	BSPF G 3/4"(male)	BSPF G 3/4"(male)
Drain Pipe (Natural Drainage)	O.D / I.D	mm	-	-
Drain Pipe (using Drain Pump)	O.D / I.D	mm	Ø 32.0 / 25.0	Ø 32.0 / 25.0
Sound Pressure Level	H/M/L	dB(A)	50.0 / 49.0 / 48.0	50.0 / 49.0 / 48.0
Sound Power Level	H/M/L	dB(A)	65.0 / 64.0 / 63.0	65.0 / 64.0 / 63.0
Connecting Cable	Communication Cable (VCTF-SB)	mm²×cores	1.0~1.5 × 2C	1.0~1.5 × 2C

Note

- Due to our policy of innovation some specifications may be changed without notification.
- Wiring cable size must comply with the applicable local and national codes. And "Electric characteristics" chapter should be considered for electrical work and design. Especially the power cable and circuit breaker should be selected in accordance with that.
- Sound Level Values are measured at Noise Measuring chamber accordance with standard. Therefore, these values depend on the ambient conditions and values are normally higher in actual operation.
- Performances are based on the following conditions :
 - Cooling
 - Condition A : Inlet/Outlet Water Temp. 7°C / 12°C, Indoor Air Temp. 27°CDB / 19°CWB
 - Condition B : Inlet/Outlet Water Temp. 10°C / 15°C, Indoor Air Temp. 27°CDB / 19°CWB
 - Condition C : Inlet/Outlet Water Temp. 7°C / 12°C, Indoor Air Temp. 25°CDB / 17.9°CWB
 - Condition D : Inlet/Outlet Water Temp. 14°C / 18°C, Indoor Air Temp. 26°CDB / 18°CWB
 - Heating
 - Condition A : Inlet/Outlet Water Temp. 45°C / 40°C, Indoor Air Temp. 20°CDB / 15°CWB
 - Condition B : Inlet Water Temp. 50°C, Indoor Air Temp. 20°CDB / 15°CWB
- Capacity, power consumption, etc. may vary depending on the product installation conditions (temperature, conditions of use).
- Main power line should be shorter than 50m. When installing a power line longer than 50m, contact LG Electronics.

3. Dimensions

3.1 Dimensional Drawings

■ M1 Chassis_Right pipe (WFCB056RG0A, WFCB066RG0A)

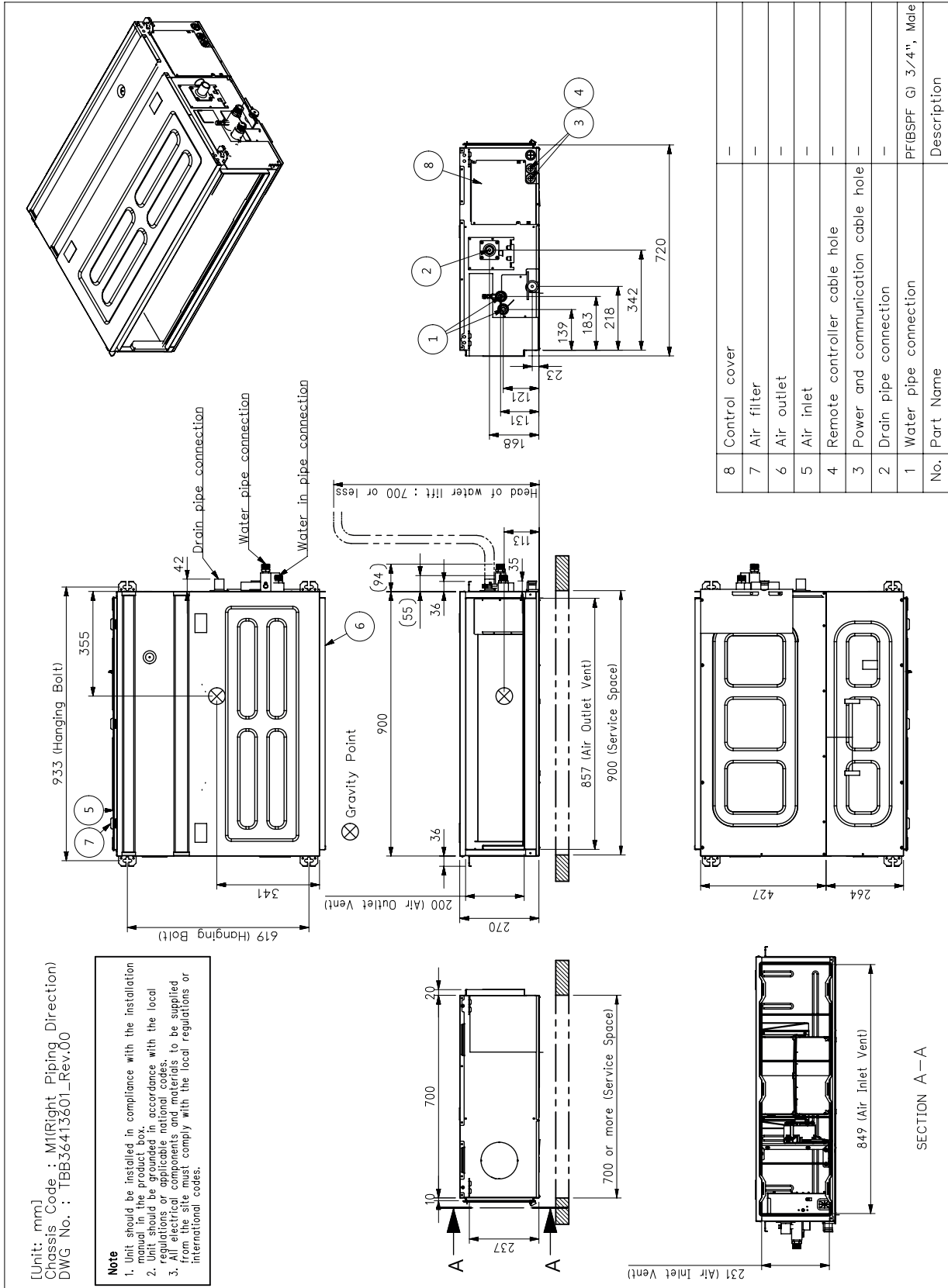

3. Dimensions

■ M1 Chassis_Left pipe (WFCB056LG0A, WFCB066LG0A)

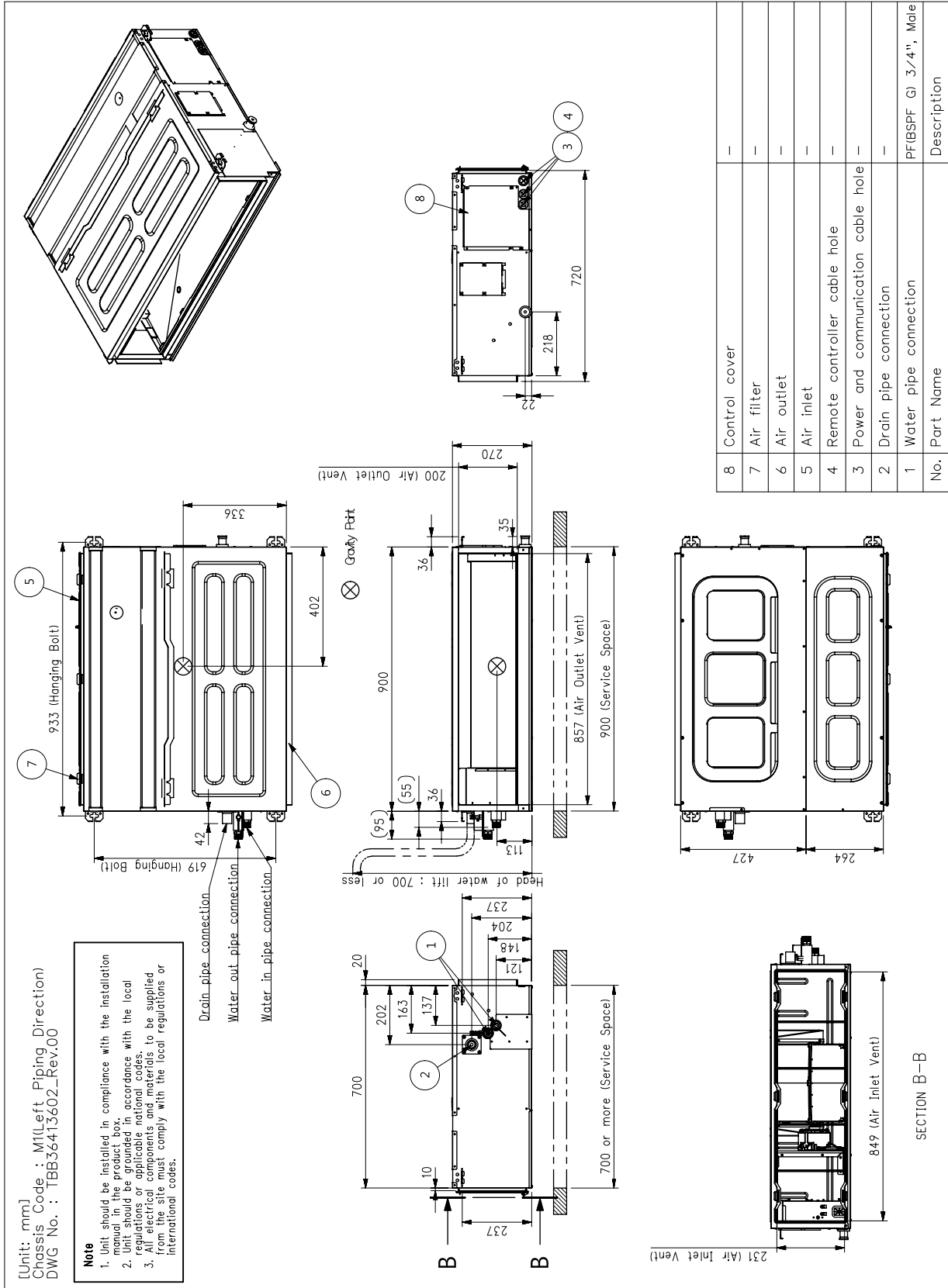

3. Dimensions

M2 Chassis _ Right pipe (WFCB090RG0A, WFCB100RG0A, WFCB109RG0A)

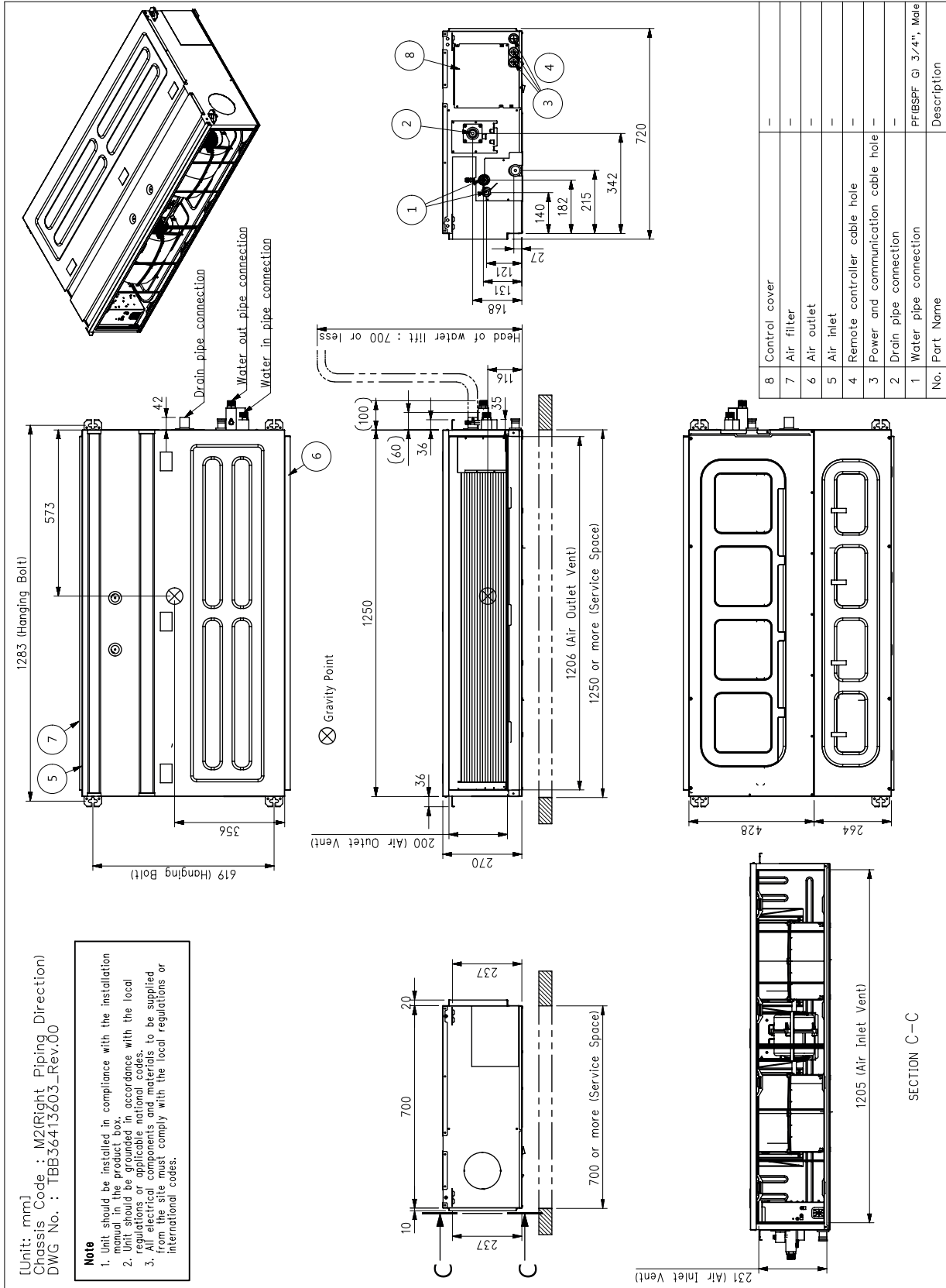

3. Dimensions

■ M2 Chassis _ Left pipe (WFCB090LG0A, WFCB100LG0A, WFCB109LG0A)

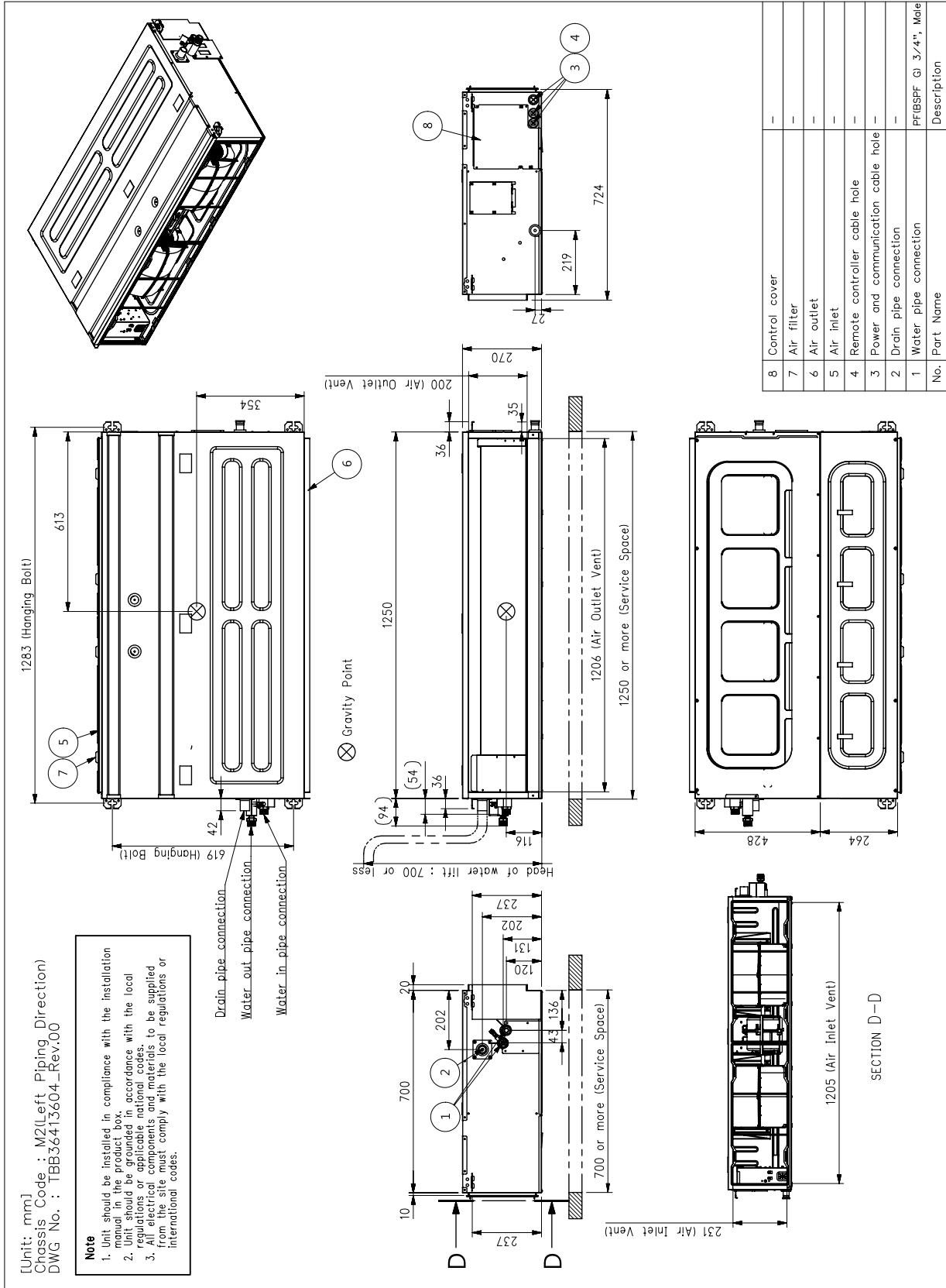

3. Dimensions

M3 Chassis _ Right pipe (WFCB127RG0A, WFCB140RG0A)

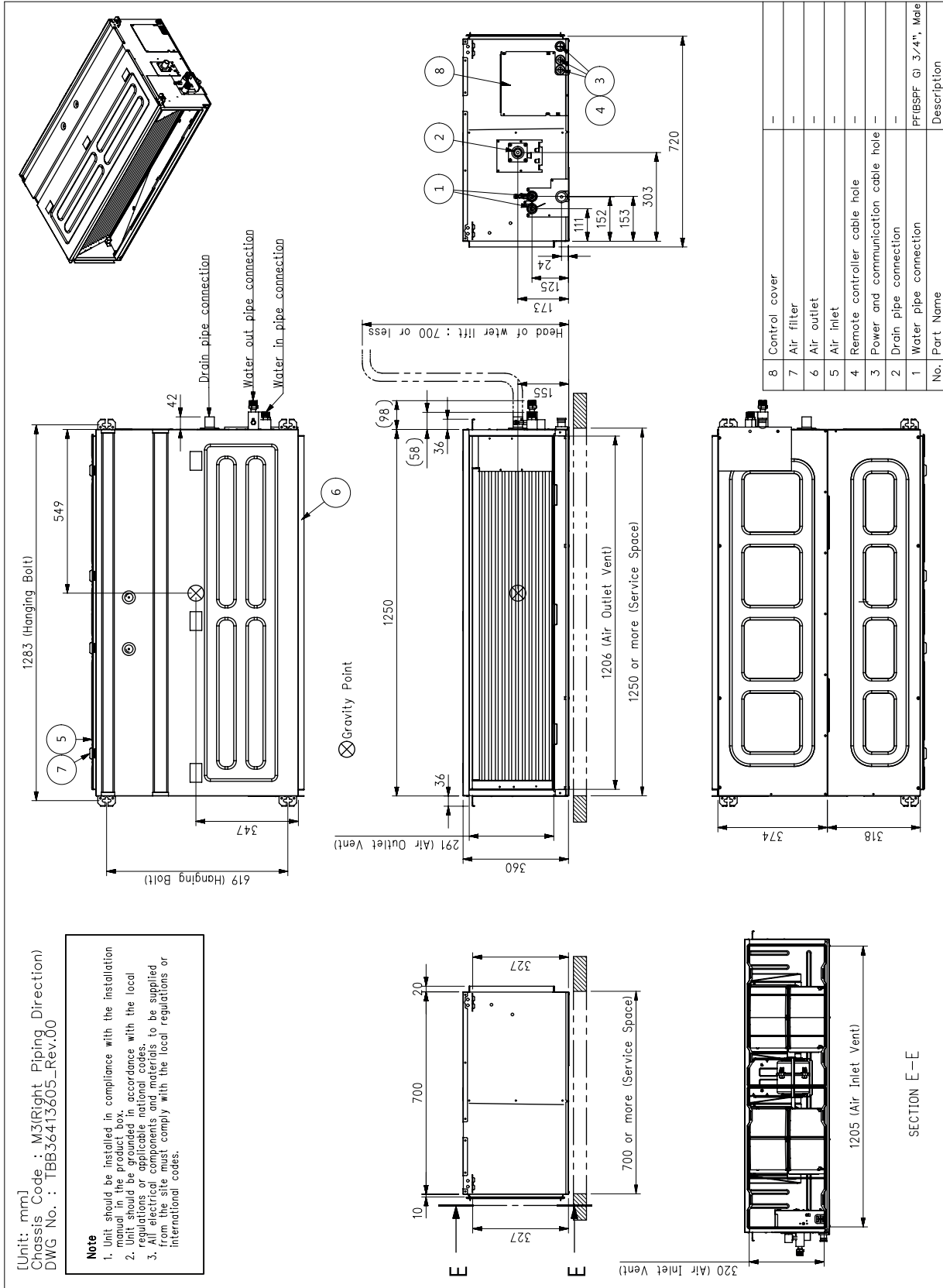

3. Dimensions

M3 Chassis _ Left pipe (WFCB127LG0A, WFCB140LG0A)

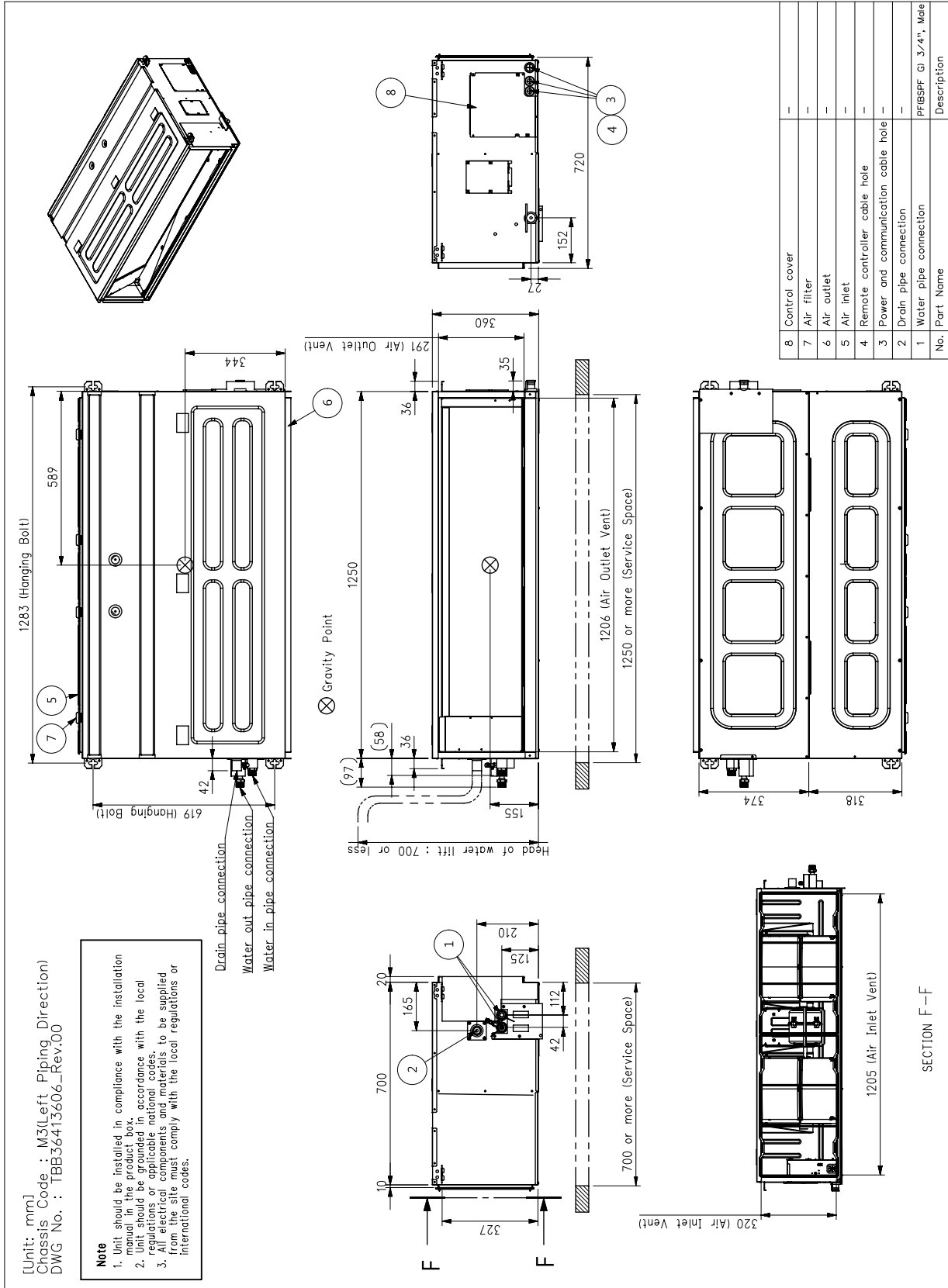

3. Dimensions

3.2 Installation Space

Top view
[Unit: mm(inch)]

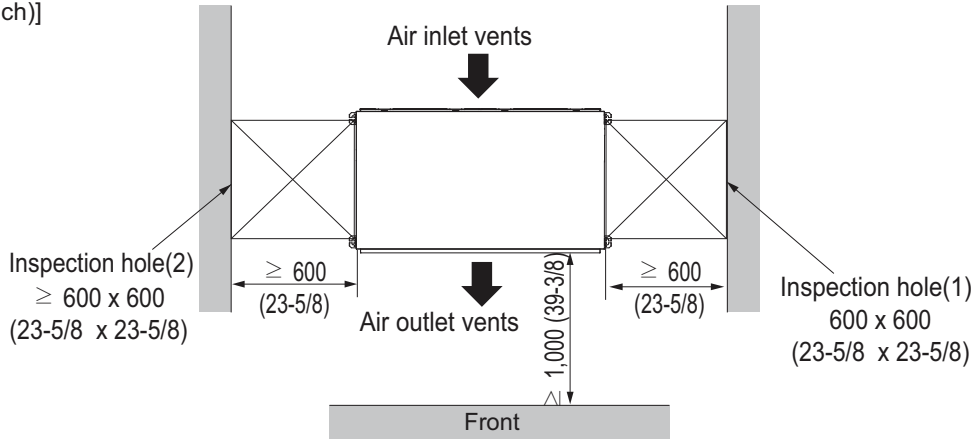

* If distance between false ceiling and actual ceiling is more than 100cm (39-3/8 inch), the number of inspection hole could be decreased to 1. But if that is less than 20cm (7-7/8 inch), the hole size should be more than size of Indoor Unit.

Front view
[Unit: mm(inch)]

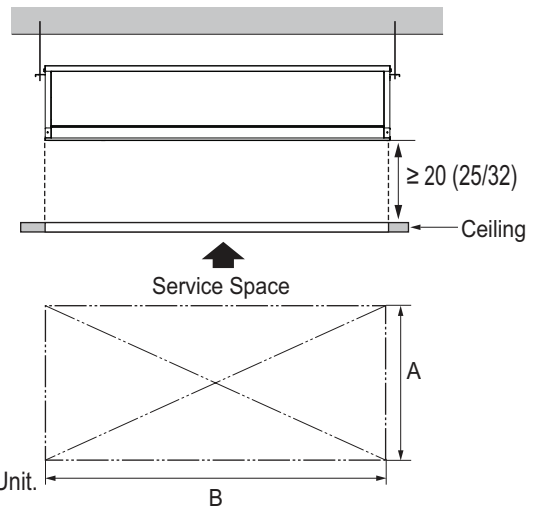
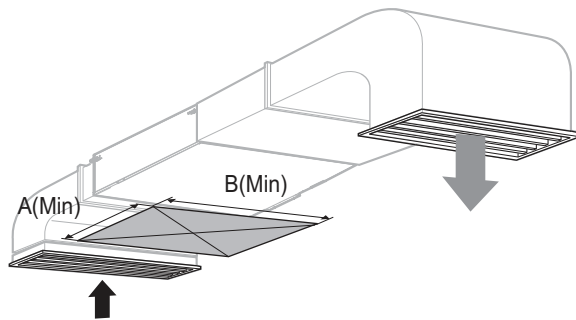

* If distance between false ceiling and actual ceiling is less than 20cm (7-7/8 inch), the hole size should be more than size of Indoor Unit.

* These figures are representative. Actual appearance of indoor unit may be different but clearances will stay the same.

Note

- Places where products are installed should not be any obstacles to the air circulation or installation. Ensure the spaces from the wall, ceiling, or other obstacles.
- According to type of indoor unit, external appearance or installed structure could be different.
- According to product type, model line up, sales region..etc, applicability of each chassis could be different.
- Install certainly the decoration panel. Cool air leakage causes sweating or falling of water-drops.

4. Piping Diagrams

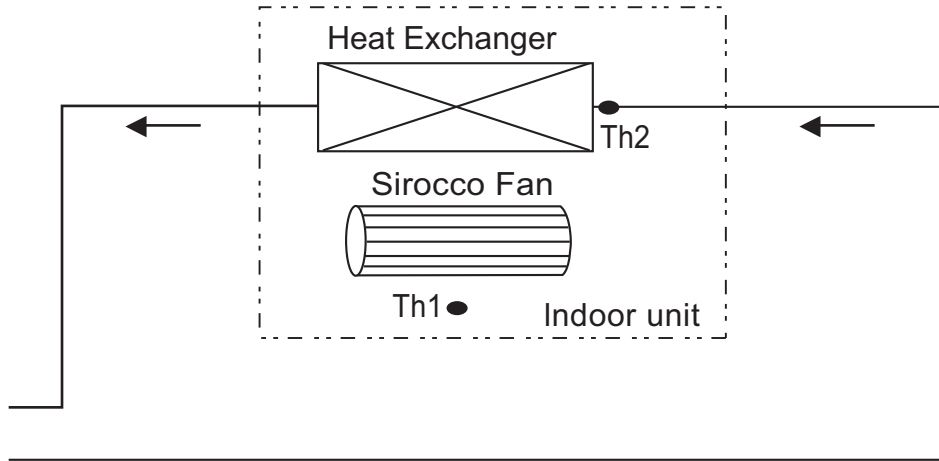

LOC.	Description
Th1	Thermistor for room air temperature
Th2	Thermistor for pipe in temperature

5. Wiring diagrams

M1, M2, M3 Chassis

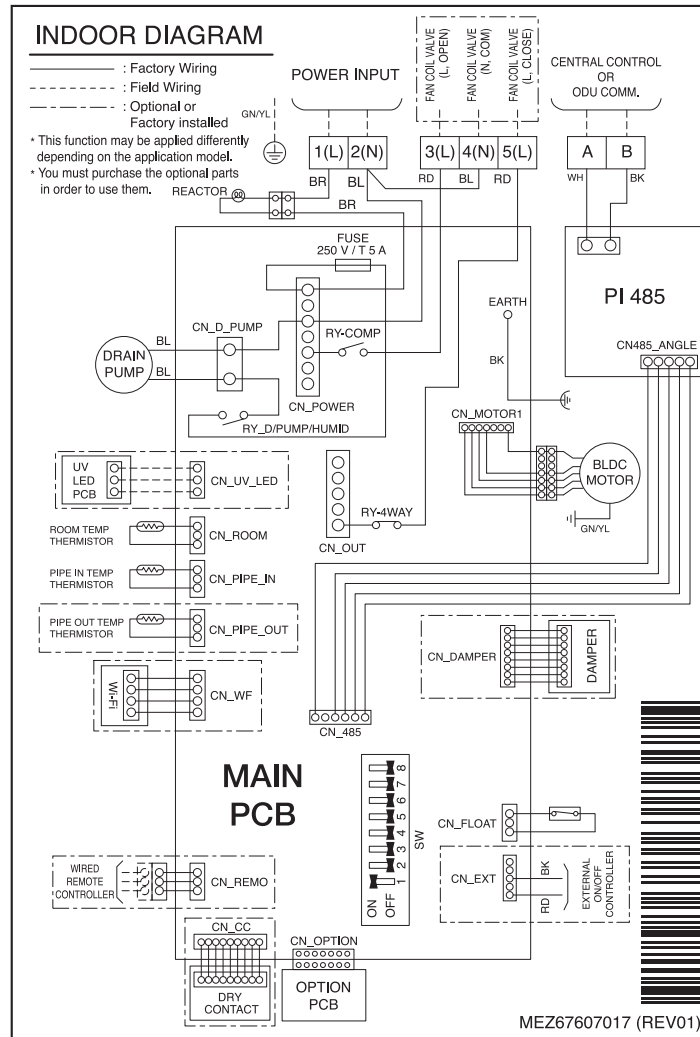

◆ Dip SW Setting Table

No.	Function	Description	Setting		Default (At the time of factory ship-out)	FCU
			OFF	ON		
SW1	Communication mode	Communication / Non communication model selection	Communication	Non communication	ON	Use
SW2	Cooling / heating mode	Cooling / heating mode selection	Cooling/heating	Cooling exclusive	OFF	Use
SW3	Group control	Master / slave selection	Master	Slave	OFF	Use
SW4	Dry contact mode	- Variable : Manual or automatic selection of wired wireless remote control - Automatic	Variable	Automatic	OFF	Use
SW5	Fan continuous operation	For Duct type	Fan continuous operation removal	Fan continuous operation	OFF	N/A
	EXTRA	Cassette type	-	-	OFF	
	Installation type	For Ceiling Suspended type For Round Cassette	Ceiling Exposed	Floor Half Concealed	OFF OFF	
SW6	Heater linkage	-	-	-	OFF	N/A
SW7	Ventilator linkage	Selection of Ventilator linkage	Linkage Removal	Working	OFF	N/A
	Vane selection (Console)	For Console type (Top/Bottom vane)	Top + Bottom Vane	Top Vane Only		
	Region selection	Selection tropical region	General model	Tropical model		
SW8	Communication method	LGAP/Modbus selection	Modbus	LGAP	OFF	Use

Note

- For product type, available Dip Switch No. could be different.
- Dip switch marked 'N/A' should be OFF. Those will be used for other product.

6. Capacity Tables

Inlet Water Temp. (°C)	Water Temp Difference (°C)	Air Temp (°C DB)	Air Temp(17°C WB)				Air Temp(19°C WB)				Air Temp(21°C WB)				Air Temp(23°C WB)			
			TC (kW)	SHC (kW)	Water Flow Rate (LPM)	Pressure Drop (kPa)	TC (kW)	SHC (kW)	Water Flow Rate (LPM)	Pressure Drop (kPa)	TC (kW)	SHC (kW)	Water Flow Rate (LPM)	Pressure Drop (kPa)	TC (kW)	SHC (kW)	Water Flow Rate (LPM)	Pressure Drop (kPa)
9	4	24	3.54	3.32	12.7	9.7	4.80	3.13	17.2	16.5	6.20	2.93	22.2	25.8	7.75	2.74	27.8	38.3
		25	3.53	3.53	12.7	9.6	4.79	3.41	17.2	16.4	6.19	3.22	22.2	25.8	7.74	3.02	27.8	38.2
		26	3.52	3.52	12.6	9.6	4.78	3.70	17.2	16.4	6.18	3.50	22.2	25.7	7.73	3.31	27.7	38.1
		27	3.52	3.52	12.6	9.6	4.77	3.98	17.1	16.3	6.17	3.79	22.1	25.6	7.72	3.59	27.7	38.0
		28	3.51	3.51	12.6	9.5	4.76	4.27	17.1	16.3	6.16	4.07	22.1	25.5	7.70	3.88	27.7	37.9
		29	3.50	3.50	12.6	9.5	4.76	4.55	17.1	16.2	6.15	4.36	22.1	25.5	7.69	4.16	27.6	37.8
	30	3.49	3.49	12.5	9.5	4.75	4.75	17.0	16.2	6.14	4.64	22.0	25.4	7.68	4.45	27.6	37.7	
	5	24	3.45	3.29	9.9	6.3	4.71	3.09	13.5	10.8	6.10	2.90	17.5	17.0	7.65	2.70	22.0	25.3
		25	3.44	3.44	9.9	6.3	4.70	3.38	13.5	10.7	6.09	3.18	17.5	16.9	7.64	2.98	21.9	25.2
		26	3.43	3.43	9.9	6.2	4.69	3.66	13.5	10.7	6.08	3.46	17.5	16.9	7.63	3.27	21.9	25.1
		27	3.42	3.42	9.8	6.2	4.68	3.94	13.4	10.7	6.07	3.75	17.4	16.8	7.62	3.55	21.9	25.1
		28	3.42	3.42	9.8	6.2	4.67	4.23	13.4	10.6	6.06	4.03	17.4	16.8	7.61	3.84	21.8	25.0
		29	3.41	3.41	9.8	6.2	4.66	4.51	13.4	10.6	6.05	4.32	17.4	16.7	7.59	4.12	21.8	24.9
	30	3.40	3.40	9.8	6.1	4.65	4.65	13.4	10.6	6.04	4.60	17.3	16.7	7.58	4.41	21.8	24.9	
	6	24	3.36	3.25	8.0	4.4	4.61	3.05	11.0	7.6	6.01	2.86	14.4	12.0	7.55	2.66	18.1	17.9
		25	3.35	3.35	8.0	4.4	4.60	3.34	11.0	7.6	6.00	3.14	14.3	12.0	7.54	2.95	18.0	17.9
		26	3.34	3.34	8.0	4.3	4.59	3.62	11.0	7.5	5.99	3.43	14.3	11.9	7.53	3.23	18.0	17.8
		27	3.33	3.33	8.0	4.3	4.59	3.91	11.0	7.5	5.97	3.71	14.3	11.9	7.52	3.52	18.0	17.8
		28	3.32	3.32	8.0	4.3	4.58	4.19	10.9	7.5	5.96	4.00	14.3	11.9	7.51	3.80	18.0	17.7
		29	3.32	3.32	7.9	4.3	4.57	4.48	10.9	7.4	5.95	4.28	14.2	11.8	7.50	4.09	17.9	17.7
	30	3.31	3.31	7.9	4.3	4.56	4.56	10.9	7.4	5.94	4.57	14.2	11.8	7.48	4.37	17.9	17.6	
	7	24	3.26	3.21	6.7	3.2	4.52	3.02	9.3	5.6	5.91	2.82	12.1	8.9	7.45	2.63	15.3	13.4
		25	3.26	3.26	6.7	3.2	4.51	3.30	9.2	5.6	5.90	3.11	12.1	8.9	7.44	2.91	15.3	13.3
		26	3.25	3.25	6.7	3.2	4.50	3.59	9.2	5.6	5.89	3.39	12.1	8.9	7.43	3.20	15.2	13.3
		27	3.24	3.24	6.6	3.2	4.49	3.87	9.2	5.5	5.88	3.68	12.1	8.8	7.42	3.48	15.2	13.3
		28	3.23	3.23	6.6	3.1	4.48	4.16	9.2	5.5	5.87	3.96	12.0	8.8	7.41	3.77	15.2	13.2
		29	3.22	3.22	6.6	3.1	4.47	4.44	9.2	5.5	5.86	4.25	12.0	8.8	7.40	4.05	15.2	13.2
	30	3.22	3.22	6.6	3.1	4.46	4.46	9.2	5.5	5.85	4.53	12.0	8.8	7.38	4.34	15.1	13.2	
	8	24	3.17	3.17	5.7	2.4	4.42	2.98	7.9	4.3	5.81	2.79	10.4	6.9	7.35	2.59	13.2	10.3
		25	3.16	3.16	5.7	2.4	4.41	3.27	7.9	4.3	5.80	3.07	10.4	6.8	7.34	2.87	13.2	10.3
26		3.16	3.16	5.7	2.4	4.40	3.55	7.9	4.3	5.79	3.36	10.4	6.8	7.33	3.16	13.2	10.3	
27		3.15	3.15	5.6	2.4	4.39	3.83	7.9	4.2	5.78	3.64	10.4	6.8	7.32	3.44	13.1	10.3	
28		3.14	3.14	5.6	2.4	4.39	4.12	7.9	4.2	5.77	3.92	10.4	6.8	7.31	3.73	13.1	10.2	
29		3.13	3.13	5.6	2.4	4.38	4.38	7.9	4.2	5.76	4.21	10.3	6.8	7.29	4.01	13.1	10.2	
30	3.12	3.12	5.6	2.4	4.37	4.37	7.8	4.2	5.75	4.49	10.3	6.7	7.28	4.30	13.1	10.2		

Note

- TC : Total capacity, SHC : Sensible Heat Capacity
- Performances are based on the following conditions :
 - Cooling
 - Condition A : Inlet/Outlet Water Temp. 7°C / 12°C, Indoor Air Temp. 27°CDB / 19°CWB
 - Condition B : Inlet/Outlet Water Temp. 10°C / 15°C, Indoor Air Temp. 27°CDB / 19°CWB
 - Condition C : Inlet/Outlet Water Temp. 7°C / 12°C, Indoor Air Temp. 25°CDB / 17.9°CWB
 - Condition D : Inlet/Outlet Water Temp. 14°C / 18°C, Indoor Air Temp. 26°CDB / 18°CWB
- Above capacity tables shows representative values according to the change in temperature or water flow rate, etc., it may vary depending on the installation conditions and the surrounding environment.

6. Capacity Tables

Inlet Water Temp. (°C)	Water Temp Difference (°C)	Air Temp (°C DB)	Air Temp(17°C WB)				Air Temp(19°C WB)				Air Temp(21°C WB)				Air Temp(23°C WB)			
			TC (kW)	SHC (kW)	Water Flow Rate (LPM)	Pressure Drop (kPa)	TC (kW)	SHC (kW)	Water Flow Rate (LPM)	Pressure Drop (kPa)	TC (kW)	SHC (kW)	Water Flow Rate (LPM)	Pressure Drop (kPa)	TC (kW)	SHC (kW)	Water Flow Rate (LPM)	Pressure Drop (kPa)
9	4	24	4.17	3.92	15.0	15.0	5.66	3.69	20.3	25.6	7.31	3.46	26.2	40.2	9.13	3.23	32.8	59.8
		25	4.16	4.16	14.9	15.0	5.65	4.02	20.3	25.6	7.29	3.79	26.2	40.1	9.12	3.56	32.7	59.6
		26	4.15	4.15	14.9	14.9	5.64	4.36	20.2	25.5	7.28	4.13	26.1	40.0	9.11	3.90	32.7	59.5
		27	4.14	4.14	14.9	14.9	5.63	4.69	20.2	25.4	7.27	4.46	26.1	39.9	9.09	4.23	32.6	59.3
		28	4.13	4.13	14.8	14.8	5.62	5.03	20.2	25.3	7.26	4.80	26.0	39.8	9.08	4.57	32.6	59.1
		29	4.13	4.13	14.8	14.7	5.60	5.36	20.1	25.2	7.25	5.13	26.0	39.6	9.07	4.90	32.5	59.0
	30	4.12	4.12	14.8	14.7	5.59	5.59	20.1	25.1	7.23	5.47	26.0	39.5	9.05	5.24	32.5	58.8	
	5	24	4.07	3.87	11.7	9.7	5.55	3.64	15.9	16.7	7.19	3.41	20.6	26.4	9.02	3.18	25.9	39.3
		25	4.06	4.06	11.6	9.7	5.54	3.98	15.9	16.7	7.18	3.75	20.6	26.3	9.00	3.52	25.9	39.2
		26	4.05	4.05	11.6	9.7	5.53	4.31	15.9	16.6	7.17	4.08	20.6	26.2	8.99	3.85	25.8	39.1
		27	4.04	4.04	11.6	9.6	5.52	4.65	15.8	16.6	7.16	4.42	20.5	26.2	8.98	4.19	25.8	39.0
		28	4.03	4.03	11.6	9.6	5.50	4.98	15.8	16.5	7.14	4.75	20.5	26.1	8.96	4.52	25.7	38.9
		29	4.02	4.02	11.5	9.5	5.49	5.32	15.8	16.5	7.13	5.09	20.5	26.0	8.95	4.86	25.7	38.8
	30	4.01	4.01	11.5	9.5	5.48	5.64	15.7	16.4	7.12	5.43	20.4	25.9	8.94	5.20	25.7	38.7	
	6	24	3.96	3.83	9.5	6.8	5.44	3.60	13.0	11.8	7.08	3.37	16.9	18.6	8.90	3.14	21.3	27.9
		25	3.95	3.95	9.4	6.7	5.43	3.94	13.0	11.7	7.07	3.70	16.9	18.6	8.89	3.47	21.3	27.8
		26	3.94	3.94	9.4	6.7	5.41	4.27	13.0	11.7	7.05	4.04	16.9	18.5	8.87	3.81	21.2	27.7
		27	3.93	3.93	9.4	6.7	5.40	4.61	12.9	11.6	7.04	4.38	16.8	18.5	8.86	4.15	21.2	27.7
		28	3.92	3.92	9.4	6.7	5.39	4.94	12.9	11.6	7.03	4.71	16.8	18.4	8.85	4.48	21.2	27.6
		29	3.91	3.91	9.4	6.6	5.38	5.28	12.9	11.5	7.02	5.05	16.8	18.4	8.83	4.82	21.1	27.5
	30	3.90	3.90	9.3	6.6	5.37	5.61	12.9	11.5	7.01	5.38	16.8	18.3	8.82	5.15	21.1	27.4	
	7	24	3.85	3.79	7.9	4.9	5.32	3.56	10.9	8.7	6.96	3.33	14.3	13.8	8.78	3.10	18.0	20.8
		25	3.84	3.84	7.9	4.9	5.31	3.89	10.9	8.6	6.95	3.66	14.3	13.8	8.77	3.43	18.0	20.7
		26	3.83	3.83	7.9	4.9	5.30	4.23	10.9	8.6	6.94	4.00	14.2	13.7	8.76	3.77	18.0	20.7
		27	3.82	3.82	7.8	4.9	5.29	4.56	10.9	8.6	6.93	4.33	14.2	13.7	8.74	4.10	17.9	20.6
		28	3.81	3.81	7.8	4.9	5.28	4.90	10.8	8.5	6.91	4.67	14.2	13.7	8.73	4.44	17.9	20.5
		29	3.80	3.80	7.8	4.8	5.27	5.23	10.8	8.5	6.90	5.00	14.2	13.6	8.72	4.77	17.9	20.5
	30	3.79	3.79	7.8	4.8	5.26	5.56	10.8	8.5	6.89	5.34	14.1	13.6	8.70	5.11	17.9	20.4	
	8	24	3.74	3.74	6.7	3.7	5.21	3.51	9.4	6.6	6.85	3.28	12.3	10.6	8.66	3.05	15.6	16.1
		25	3.73	3.73	6.7	3.7	5.20	3.85	9.3	6.6	6.84	3.62	12.3	10.6	8.65	3.39	15.5	16.0
26		3.72	3.72	6.7	3.7	5.19	4.18	9.3	6.6	6.82	3.95	12.2	10.6	8.64	3.72	15.5	16.0	
27		3.71	3.71	6.7	3.7	5.18	4.52	9.3	6.6	6.81	4.29	12.2	10.5	8.62	4.06	15.5	15.9	
28		3.70	3.70	6.6	3.7	5.17	4.85	9.3	6.5	6.80	4.63	12.2	10.5	8.61	4.40	15.5	15.9	
29		3.69	3.69	6.6	3.7	5.16	5.16	9.3	6.5	6.79	4.96	12.2	10.5	8.60	4.73	15.4	15.8	
30	3.68	3.68	6.6	3.6	5.15	5.15	9.2	6.5	6.78	5.30	12.2	10.4	8.58	5.07	15.4	15.8		

Note

- TC : Total capacity, SHC : Sensible Heat Capacity
- Performances are based on the following conditions :
 - Cooling
 - Condition A : Inlet/Outlet Water Temp. 7°C / 12°C, Indoor Air Temp. 27°CDB / 19°CWB
 - Condition B : Inlet/Outlet Water Temp. 10°C / 15°C, Indoor Air Temp. 27°CDB / 19°CWB
 - Condition C : Inlet/Outlet Water Temp. 7°C / 12°C, Indoor Air Temp. 25°CDB / 17.9°CWB
 - Condition D : Inlet/Outlet Water Temp. 14°C / 18°C, Indoor Air Temp. 26°CDB / 18°CWB
- Above capacity tables shows representative values according to the change in temperature or water flow rate, etc., it may vary depending on the installation conditions and the surrounding environment.

6. Capacity Tables

Inlet Water Temp. (°C)	Water Temp Difference (°C)	Air Temp (°C DB)	Air Temp(17°C WB)				Air Temp(19°C WB)				Air Temp(21°C WB)				Air Temp(23°C WB)			
			TC (kW)	SHC (kW)	Water Flow Rate (LPM)	Pressure Drop (kPa)	TC (kW)	SHC (kW)	Water Flow Rate (LPM)	Pressure Drop (kPa)	TC (kW)	SHC (kW)	Water Flow Rate (LPM)	Pressure Drop (kPa)	TC (kW)	SHC (kW)	Water Flow Rate (LPM)	Pressure Drop (kPa)
9	4	24	5.70	5.27	20.5	16.2	7.72	4.98	27.7	27.7	9.96	4.69	35.7	43.5	12.44	4.40	44.6	64.7
		25	5.69	5.69	20.4	16.2	7.71	5.42	27.7	27.6	9.94	5.13	35.7	43.4	12.42	4.84	44.6	64.7
		26	5.67	5.67	20.4	16.1	7.69	5.87	27.6	27.5	9.93	5.58	35.6	43.3	12.41	5.29	44.5	64.4
		27	5.66	5.66	20.3	16.0	7.68	6.31	27.5	27.4	9.91	6.02	35.6	43.2	12.39	5.74	44.5	64.3
		28	5.65	5.65	20.3	16.0	7.66	6.76	27.5	27.4	9.89	6.47	35.5	43.0	12.37	6.18	44.4	64.1
		29	5.63	5.63	20.2	15.9	7.65	7.20	27.4	27.3	9.88	6.92	35.5	42.9	12.35	6.63	44.3	63.9
	30	5.62	5.62	20.2	15.8	7.63	7.63	27.4	27.2	9.86	7.36	35.4	42.8	12.33	7.07	44.3	63.8	
	5	24	5.55	5.21	15.9	10.5	7.57	4.92	21.7	18.1	9.80	4.63	28.1	28.5	12.28	4.34	35.3	42.5
		25	5.54	5.54	15.9	10.4	7.55	5.36	21.7	18.0	9.79	5.07	28.1	28.4	12.26	4.79	35.2	42.4
		26	5.53	5.53	15.9	10.4	7.54	5.81	21.6	17.9	9.77	5.52	28.1	28.3	12.25	5.23	35.2	42.3
		27	5.51	5.51	15.8	10.3	7.53	6.25	21.6	17.9	9.76	5.97	28.0	28.3	12.23	5.68	35.1	42.2
		28	5.50	5.50	15.8	10.3	7.51	6.70	21.6	17.8	9.74	6.41	28.0	28.2	12.21	6.12	35.1	42.1
		29	5.49	5.49	15.8	10.3	7.50	7.14	21.5	17.8	9.72	6.86	27.9	28.1	12.19	6.57	35.0	42.0
	6	24	5.48	5.48	15.7	10.2	7.48	7.48	21.5	17.7	9.71	7.30	27.9	28.0	12.18	7.02	35.0	41.9
		25	5.40	5.15	12.9	7.3	7.42	4.86	17.7	12.6	9.65	4.57	23.1	20.1	12.12	4.28	29.0	30.1
		26	5.39	5.39	12.9	7.2	7.40	5.30	17.7	12.6	9.63	5.02	23.0	20.0	12.11	4.73	29.0	30.0
		27	5.38	5.38	12.9	7.2	7.39	5.75	17.7	12.6	9.62	5.46	23.0	20.0	12.09	5.17	28.9	29.9
		28	5.37	5.37	12.8	7.2	7.37	6.20	17.6	12.5	9.60	5.91	23.0	19.9	12.07	5.62	28.9	29.8
		29	5.35	5.35	12.8	7.1	7.36	6.64	17.6	12.5	9.59	6.35	22.9	19.8	12.05	6.06	28.8	29.8
	7	24	5.34	5.34	12.8	7.1	7.35	7.09	17.6	12.4	9.57	6.80	22.9	19.8	12.03	6.51	28.8	29.7
		25	5.33	5.33	12.7	7.1	7.33	7.33	17.5	12.4	9.55	7.24	22.9	19.7	12.02	6.96	28.8	29.6
		26	5.26	5.09	10.8	5.3	7.27	4.80	14.9	9.3	9.49	4.51	19.5	14.9	11.96	4.22	24.5	22.4
		27	5.24	5.24	10.8	5.3	7.25	5.25	14.9	9.3	9.48	4.96	19.4	14.8	11.95	4.67	24.5	22.3
		28	5.23	5.23	10.7	5.3	7.24	5.69	14.8	9.2	9.46	5.40	19.4	14.8	11.93	5.11	24.5	22.2
		29	5.22	5.22	10.7	5.2	7.22	6.14	14.8	9.2	9.45	5.85	19.4	14.7	11.91	5.56	24.4	22.2
	8	24	5.20	5.20	10.7	5.2	7.21	6.58	14.8	9.2	9.43	6.29	19.3	14.7	11.89	6.01	24.4	22.1
		25	5.19	5.19	10.6	5.2	7.19	7.03	14.8	9.1	9.41	6.74	19.3	14.7	11.88	6.45	24.4	22.1
		26	5.18	5.18	10.6	5.2	7.18	7.18	14.7	9.1	9.40	7.19	19.3	14.6	11.86	6.90	24.3	22.0
		27	5.11	5.03	9.2	4.0	7.11	4.74	12.8	7.1	9.34	4.45	16.8	11.4	11.80	4.16	21.2	17.3
		28	5.09	5.09	9.1	4.0	7.10	5.19	12.7	7.1	9.32	4.90	16.7	11.4	11.79	4.61	21.2	17.2
29		5.08	5.08	9.1	4.0	7.08	5.63	12.7	7.1	9.30	5.34	16.7	11.4	11.77	5.05	21.1	17.2	
9	8	27	5.07	5.07	9.1	3.9	7.07	6.08	12.7	7.0	9.29	5.79	16.7	11.3	11.75	5.50	21.1	17.1
		28	5.06	5.06	9.1	3.9	7.06	6.52	12.7	7.0	9.27	6.24	16.6	11.3	11.73	5.95	21.1	17.1
		29	5.04	5.04	9.0	3.9	7.04	6.97	12.6	7.0	9.26	6.68	16.6	11.3	11.71	6.39	21.0	17.0
30	5.03	5.03	9.0	3.9	7.03	7.03	12.6	7.0	9.24	7.13	16.6	11.2	11.70	6.84	21.0	17.0		

Note

1. TC : Total capacity, SHC : Sensible Heat Capacity
2. Performances are based on the following conditions :
 - 1) Cooling
 - Condition A : Inlet/Outlet Water Temp. 7°C / 12°C, Indoor Air Temp. 27°CDB / 19°CWB
 - Condition B : Inlet/Outlet Water Temp. 10°C / 15°C, Indoor Air Temp. 27°CDB / 19°CWB
 - Condition C : Inlet/Outlet Water Temp. 7°C / 12°C, Indoor Air Temp. 25°CDB / 17.9°CWB
 - Condition D : Inlet/Outlet Water Temp. 14°C / 18°C, Indoor Air Temp. 26°CDB / 18°CWB
3. Above capacity tables shows representative values according to the change in temperature or water flow rate, etc., it may vary depending on the installation conditions and the surrounding environment.

6. Capacity Tables

Inlet Water Temp. (°C)	Water Temp Difference (°C)	Air Temp (°C DB)	Air Temp(17°C WB)				Air Temp(19°C WB)				Air Temp(21°C WB)				Air Temp(23°C WB)			
			TC (kW)	SHC (kW)	Water Flow Rate (LPM)	Pressure Drop (kPa)	TC (kW)	SHC (kW)	Water Flow Rate (LPM)	Pressure Drop (kPa)	TC (kW)	SHC (kW)	Water Flow Rate (LPM)	Pressure Drop (kPa)	TC (kW)	SHC (kW)	Water Flow Rate (LPM)	Pressure Drop (kPa)
9	4	24	6.33	5.85	22.7	22.3	8.58	5.53	30.8	38.1	11.07	5.21	39.7	60.0	13.82	4.89	49.6	89.2
		25	6.32	6.32	22.7	22.2	8.56	6.02	30.7	38.0	11.05	5.70	39.6	59.8	13.80	5.38	49.5	89.0
		26	6.30	6.30	22.6	22.1	8.55	6.52	30.7	37.9	11.03	6.20	39.6	59.6	13.78	5.88	49.5	88.8
		27	6.29	6.29	22.6	22.0	8.53	7.01	30.6	37.8	11.01	6.69	39.5	59.5	13.76	6.37	49.4	88.6
		28	6.28	6.28	22.5	21.9	8.51	7.51	30.6	37.6	10.99	7.19	39.5	59.3	13.74	6.87	49.3	88.3
		29	6.26	6.26	22.5	21.9	8.50	8.00	30.5	37.5	10.98	7.68	39.4	59.1	13.72	7.36	49.3	88.1
	30	6.25	6.25	22.4	21.8	8.48	8.48	30.4	37.4	10.96	8.18	39.3	58.9	13.70	7.86	49.2	87.9	
	5	24	6.17	5.79	17.7	14.4	8.41	5.46	24.1	24.8	10.89	5.14	31.3	39.2	13.65	4.82	39.2	58.6
		25	6.15	6.15	17.7	14.3	8.39	5.96	24.1	24.7	10.88	5.64	31.2	39.1	13.63	5.32	39.1	58.4
		26	6.14	6.14	17.6	14.3	8.38	6.45	24.1	24.6	10.86	6.13	31.2	39.0	13.61	5.81	39.1	58.3
		27	6.13	6.13	17.6	14.2	8.36	6.95	24.0	24.6	10.84	6.63	31.1	38.9	13.59	6.31	39.0	58.1
		28	6.11	6.11	17.5	14.2	8.35	7.44	24.0	24.5	10.82	7.12	31.1	38.8	13.57	6.80	39.0	58.0
		29	6.10	6.10	17.5	14.1	8.33	7.94	23.9	24.4	10.80	7.62	31.0	38.7	13.55	7.30	38.9	57.8
	30	6.08	6.08	17.5	14.0	8.31	8.31	23.9	24.3	10.79	8.11	31.0	38.5	13.53	7.80	38.8	57.7	
	6	24	6.00	5.72	14.4	10.0	8.24	5.40	19.7	17.4	10.72	5.08	25.6	27.6	13.47	4.76	32.2	41.4
		25	5.99	5.99	14.3	9.9	8.23	5.89	19.7	17.3	10.70	5.57	25.6	27.5	13.45	5.25	32.2	41.3
		26	5.98	5.98	14.3	9.9	8.21	6.39	19.6	17.3	10.69	6.07	25.6	27.4	13.43	5.75	32.1	41.2
		27	5.96	5.96	14.3	9.8	8.19	6.88	19.6	17.2	10.67	6.56	25.5	27.4	13.41	6.24	32.1	41.0
		28	5.95	5.95	14.2	9.8	8.18	7.38	19.6	17.1	10.65	7.06	25.5	27.3	13.39	6.74	32.0	40.9
		29	5.93	5.93	14.2	9.8	8.16	7.87	19.5	17.1	10.63	7.55	25.4	27.2	13.37	7.23	32.0	40.8
	30	5.92	5.92	14.2	9.7	8.15	8.15	19.5	17.0	10.61	8.05	25.4	27.1	13.35	7.73	31.9	40.7	
	7	24	5.84	5.65	12.0	7.3	8.07	5.33	16.6	12.8	10.55	5.01	21.6	20.4	13.29	4.69	27.3	30.8
		25	5.83	5.83	11.9	7.2	8.06	5.83	16.5	12.7	10.53	5.51	21.6	20.4	13.27	5.19	27.2	30.7
		26	5.81	5.81	11.9	7.2	8.04	6.32	16.5	12.7	10.51	6.00	21.6	20.3	13.25	5.68	27.2	30.6
		27	5.80	5.80	11.9	7.2	8.03	6.82	16.5	12.6	10.49	6.50	21.5	20.3	13.23	6.18	27.1	30.5
		28	5.78	5.78	11.9	7.1	8.01	7.31	16.4	12.6	10.48	6.99	21.5	20.2	13.21	6.67	27.1	30.4
		29	5.77	5.77	11.8	7.1	7.99	7.81	16.4	12.6	10.46	7.49	21.4	20.1	13.19	7.17	27.1	30.3
	30	5.75	5.75	11.8	7.1	7.98	7.98	16.4	12.5	10.44	7.98	21.4	20.1	13.17	7.66	27.0	30.3	
	8	24	5.67	5.59	10.2	5.5	7.90	5.27	14.2	9.7	10.37	4.95	18.6	15.7	13.11	4.62	23.5	23.7
		25	5.66	5.66	10.2	5.5	7.89	5.76	14.2	9.7	10.36	5.44	18.6	15.6	13.09	5.12	23.5	23.7
26		5.65	5.65	10.1	5.4	7.87	6.26	14.1	9.7	10.34	5.94	18.6	15.6	13.07	5.62	23.5	23.6	
27		5.63	5.63	10.1	5.4	7.86	6.75	14.1	9.6	10.32	6.43	18.5	15.6	13.06	6.11	23.4	23.5	
28		5.62	5.62	10.1	5.4	7.84	7.25	14.1	9.6	10.30	6.93	18.5	15.5	13.04	6.61	23.4	23.5	
29		5.60	5.60	10.1	5.4	7.82	7.74	14.0	9.6	10.29	7.42	18.5	15.5	13.02	7.10	23.4	23.4	
30	5.59	5.59	10.0	5.3	7.81	7.81	14.0	9.5	10.27	7.92	18.4	15.4	13.00	7.60	23.3	23.3		

Note

- TC : Total capacity, SHC : Sensible Heat Capacity
- Performances are based on the following conditions :
 - Cooling
 - Condition A : Inlet/Outlet Water Temp. 7°C / 12°C, Indoor Air Temp. 27°CDB / 19°CWB
 - Condition B : Inlet/Outlet Water Temp. 10°C / 15°C, Indoor Air Temp. 27°CDB / 19°CWB
 - Condition C : Inlet/Outlet Water Temp. 7°C / 12°C, Indoor Air Temp. 25°CDB / 17.9°CWB
 - Condition D : Inlet/Outlet Water Temp. 14°C / 18°C, Indoor Air Temp. 26°CDB / 18°CWB
- Above capacity tables shows representative values according to the change in temperature or water flow rate, etc., it may vary depending on the installation conditions and the surrounding environment.

6. Capacity Tables

Inlet Water Temp. (°C)	Water Temp Difference (°C)	Air Temp (°C DB)	Air Temp(17°C WB)				Air Temp(19°C WB)				Air Temp(21°C WB)				Air Temp(23°C WB)			
			TC (kW)	SHC (kW)	Water Flow Rate (LPM)	Pressure Drop (kPa)	TC (kW)	SHC (kW)	Water Flow Rate (LPM)	Pressure Drop (kPa)	TC (kW)	SHC (kW)	Water Flow Rate (LPM)	Pressure Drop (kPa)	TC (kW)	SHC (kW)	Water Flow Rate (LPM)	Pressure Drop (kPa)
9	4	24	6.87	6.67	24.7	24.8	9.34	6.22	33.5	42.7	12.08	5.78	43.3	67.5	15.12	5.33	54.3	100.9
		25	6.86	6.86	24.6	24.7	9.32	6.81	33.4	42.5	12.05	6.36	43.3	67.3	15.10	5.91	54.2	100.6
		26	6.84	6.84	24.5	24.6	9.30	7.39	33.4	42.4	12.03	6.95	43.2	67.1	15.08	6.50	54.1	100.4
		27	6.82	6.82	24.5	24.5	9.28	7.98	33.3	42.2	12.01	7.53	43.1	66.8	15.05	7.08	54.0	100.1
		28	6.81	6.81	24.4	24.4	9.26	8.56	33.2	42.1	11.99	8.12	43.0	66.6	15.03	7.67	53.9	99.8
		29	6.79	6.79	24.4	24.3	9.24	9.15	33.2	41.9	11.97	8.70	43.0	66.4	15.01	8.26	53.9	99.5
	30	6.77	6.77	24.3	24.2	9.22	9.72	33.1	41.8	11.95	9.29	42.9	66.2	14.98	8.84	53.8	99.3	
	5	24	6.69	6.60	19.2	16.0	9.15	6.15	26.3	27.7	11.89	5.70	34.1	44.1	14.93	5.26	42.9	66.2
		25	6.68	6.68	19.2	15.9	9.13	6.74	26.2	27.6	11.87	6.29	34.1	43.9	14.90	5.84	42.8	66.0
		26	6.66	6.66	19.1	15.8	9.11	7.32	26.2	27.5	11.84	6.87	34.0	43.8	14.88	6.43	42.7	65.8
		27	6.64	6.64	19.1	15.8	9.10	7.91	26.1	27.4	11.82	7.46	33.9	43.7	14.86	7.01	42.7	65.6
		28	6.63	6.63	19.0	15.7	9.08	8.49	26.1	27.3	11.80	8.05	33.9	43.5	14.83	7.60	42.6	65.4
		29	6.61	6.61	19.0	15.6	9.06	9.06	26.0	27.2	11.78	8.63	33.8	43.4	14.81	8.19	42.5	65.2
	30	6.59	6.59	18.9	15.6	9.04	9.64	26.0	27.1	11.76	9.22	33.8	43.3	14.79	8.77	42.5	65.1	
	6	24	6.51	6.51	15.6	11.1	8.97	6.08	21.5	19.4	11.70	5.63	28.0	31.0	14.73	5.19	35.2	46.7
		25	6.50	6.50	15.5	11.0	8.95	6.67	21.4	19.3	11.67	6.22	27.9	30.9	14.71	5.77	35.2	46.6
		26	6.48	6.48	15.5	11.0	8.93	7.25	21.4	19.3	11.65	6.80	27.9	30.8	14.69	6.36	35.1	46.4
		27	6.46	6.46	15.5	10.9	8.91	7.83	21.3	19.2	11.63	7.39	27.8	30.7	14.66	6.94	35.1	46.3
		28	6.45	6.45	15.4	10.9	8.89	8.42	21.3	19.1	11.61	7.97	27.8	30.6	14.64	7.53	35.0	46.2
		29	6.43	6.43	15.4	10.8	8.87	8.87	21.2	19.0	11.59	8.56	27.7	30.5	14.62	8.12	35.0	46.0
	30	6.41	6.41	15.3	10.8	8.85	8.85	21.2	19.0	11.57	9.15	27.7	30.4	14.59	8.70	34.9	45.9	
	7	24	6.33	6.33	13.0	8.1	8.78	6.01	18.0	14.3	11.50	5.56	23.6	22.9	14.53	5.11	29.8	34.7
		25	6.32	6.32	13.0	8.0	8.76	6.59	18.0	14.2	11.48	6.15	23.5	22.9	14.51	5.70	29.8	34.6
		26	6.30	6.30	12.9	8.0	8.74	7.18	17.9	14.2	11.46	6.73	23.5	22.8	14.49	6.29	29.7	34.5
		27	6.28	6.28	12.9	7.9	8.72	7.76	17.9	14.1	11.44	7.32	23.5	22.7	14.47	6.87	29.7	34.4
		28	6.27	6.27	12.9	7.9	8.71	8.35	17.9	14.0	11.42	7.90	23.4	22.6	14.44	7.46	29.6	34.3
		29	6.25	6.25	12.8	7.9	8.69	8.69	17.8	14.0	11.40	8.49	23.4	22.6	14.42	8.04	29.6	34.2
	30	6.23	6.23	12.8	7.8	8.67	8.67	17.8	13.9	11.38	9.07	23.3	22.5	14.40	8.63	29.5	34.1	
	8	24	6.15	6.15	11.0	6.1	8.59	5.94	15.4	10.9	11.31	5.49	20.3	17.6	14.34	5.04	25.7	26.7
		25	6.14	6.14	11.0	6.0	8.58	6.52	15.4	10.8	11.29	6.08	20.3	17.5	14.31	5.63	25.7	26.6
26		6.12	6.12	11.0	6.0	8.56	7.11	15.4	10.8	11.27	6.66	20.2	17.5	14.29	6.22	25.6	26.6	
27		6.10	6.10	10.9	6.0	8.54	7.69	15.3	10.7	11.25	7.25	20.2	17.4	14.27	6.80	25.6	26.5	
28		6.09	6.09	10.9	6.0	8.52	8.28	15.3	10.7	11.23	7.83	20.1	17.4	14.24	7.39	25.6	26.4	
29		6.07	6.07	10.9	5.9	8.50	8.50	15.3	10.7	11.21	8.42	20.1	17.3	14.22	7.97	25.5	26.3	
30	6.05	6.05	10.9	5.9	8.48	8.48	15.2	10.6	11.19	9.00	20.1	17.3	14.20	8.56	25.5	26.3		

Note

- TC : Total capacity, SHC : Sensible Heat Capacity
- Performances are based on the following conditions :
 - Cooling
 - Condition A : Inlet/Outlet Water Temp. 7°C / 12°C, Indoor Air Temp. 27°CDB / 19°CWB
 - Condition B : Inlet/Outlet Water Temp. 10°C / 15°C, Indoor Air Temp. 27°CDB / 19°CWB
 - Condition C : Inlet/Outlet Water Temp. 7°C / 12°C, Indoor Air Temp. 25°CDB / 17.9°CWB
 - Condition D : Inlet/Outlet Water Temp. 14°C / 18°C, Indoor Air Temp. 26°CDB / 18°CWB
- Above capacity tables shows representative values according to the change in temperature or water flow rate, etc., it may vary depending on the installation conditions and the surrounding environment.

6. Capacity Tables

Inlet Water Temp. (°C)	Water Temp Difference (°C)	Air Temp (°C DB)	Air Temp(17°C WB)				Air Temp(19°C WB)				Air Temp(21°C WB)				Air Temp(23°C WB)			
			TC (kW)	SHC (kW)	Water Flow Rate (LPM)	Pressure Drop (kPa)	TC (kW)	SHC (kW)	Water Flow Rate (LPM)	Pressure Drop (kPa)	TC (kW)	SHC (kW)	Water Flow Rate (LPM)	Pressure Drop (kPa)	TC (kW)	SHC (kW)	Water Flow Rate (LPM)	Pressure Drop (kPa)
9	4	24	8.03	7.54	28.8	23.3	10.89	7.09	39.1	40.0	14.06	6.65	50.4	63.2	17.58	6.21	63.1	94.4
		25	8.01	8.01	28.8	23.2	10.87	7.74	39.0	39.9	14.04	7.30	50.4	63.0	17.55	6.85	63.0	94.1
		26	7.99	7.99	28.7	23.1	10.85	8.38	38.9	39.8	14.01	7.94	50.3	62.8	17.53	7.50	62.9	93.9
		27	7.97	7.97	28.6	23.0	10.83	9.03	38.8	39.6	13.99	8.59	50.2	62.6	17.50	8.14	62.8	93.6
		28	7.96	7.96	28.6	22.9	10.81	9.67	38.8	39.5	13.97	9.23	50.1	62.5	17.47	8.79	62.7	93.4
		29	7.94	7.94	28.5	22.8	10.78	10.32	38.7	39.4	13.94	9.88	50.0	62.3	17.45	9.44	62.6	93.1
	30	7.92	7.92	28.4	22.7	10.76	10.96	38.6	39.2	13.92	10.52	50.0	62.1	17.42	10.08	62.5	92.9	
	5	24	7.82	7.45	22.5	15.0	10.68	7.01	30.6	26.0	13.84	6.57	39.7	41.3	17.35	6.12	49.8	61.8
		25	7.80	7.80	22.4	14.9	10.65	7.66	30.6	25.9	13.82	7.21	39.7	41.1	17.33	6.77	49.7	61.6
		26	7.79	7.79	22.4	14.9	10.63	8.30	30.5	25.8	13.79	7.86	39.6	41.0	17.30	7.41	49.7	61.5
		27	7.77	7.77	22.3	14.8	10.61	8.95	30.5	25.7	13.77	8.50	39.5	40.9	17.27	8.06	49.6	61.3
		28	7.75	7.75	22.2	14.8	10.59	9.59	30.4	25.6	13.75	9.15	39.5	40.8	17.25	8.71	49.5	61.1
		29	7.73	7.73	22.2	14.7	10.57	10.23	30.3	25.6	13.72	9.79	39.4	40.6	17.22	9.35	49.5	61.0
	30	7.71	7.71	22.1	14.6	10.55	10.88	30.3	25.5	13.70	10.44	39.3	40.5	17.20	10.00	49.4	60.8	
	6	24	7.61	7.37	18.2	10.4	10.46	6.93	25.0	18.2	13.62	6.48	32.6	29.0	17.13	6.04	41.0	43.6
		25	7.60	7.60	18.2	10.3	10.44	7.57	25.0	18.1	13.60	7.13	32.5	28.9	17.10	6.69	40.9	43.5
		26	7.58	7.58	18.1	10.3	10.42	8.22	24.9	18.0	13.57	7.77	32.5	28.8	17.07	7.33	40.9	43.3
		27	7.56	7.56	18.1	10.3	10.40	8.86	24.9	18.0	13.55	8.42	32.4	28.7	17.05	7.98	40.8	43.2
		28	7.54	7.54	18.0	10.2	10.38	9.51	24.8	17.9	13.53	9.07	32.4	28.6	17.02	8.62	40.7	43.1
		29	7.52	7.52	18.0	10.2	10.36	10.15	24.8	17.9	13.50	9.71	32.3	28.6	17.00	9.27	40.7	43.0
	30	7.50	7.50	17.9	10.1	10.34	10.79	24.7	17.8	13.48	10.36	32.3	28.5	16.97	9.92	40.6	42.9	
	7	24	7.40	7.29	15.2	7.5	10.25	6.84	21.0	13.3	13.40	6.40	27.5	21.4	16.90	5.96	34.7	32.3
		25	7.39	7.39	15.1	7.5	10.22	7.49	21.0	13.3	13.38	7.05	27.4	21.4	16.87	6.60	34.6	32.3
		26	7.37	7.37	15.1	7.5	10.20	8.13	20.9	13.3	13.35	7.69	27.4	21.3	16.85	7.25	34.6	32.2
		27	7.35	7.35	15.1	7.4	10.18	8.78	20.9	13.2	13.33	8.34	27.3	21.2	16.82	7.89	34.5	32.1
		28	7.33	7.33	15.0	7.4	10.16	9.42	20.8	13.2	13.31	8.98	27.3	21.2	16.80	8.54	34.4	32.0
		29	7.31	7.31	15.0	7.4	10.14	10.07	20.8	13.1	13.28	9.63	27.2	21.1	16.77	9.19	34.4	31.9
	30	7.29	7.29	15.0	7.4	10.12	10.72	20.8	13.1	13.26	10.27	27.2	21.0	16.75	9.83	34.3	31.8	
	8	24	7.19	7.19	12.9	5.7	10.03	6.76	18.0	10.2	13.18	6.32	23.6	16.4	16.67	5.87	29.9	24.9
		25	7.17	7.17	12.9	5.7	10.01	7.41	18.0	10.1	13.15	6.96	23.6	16.4	16.65	6.52	29.9	24.8
26		7.16	7.16	12.8	5.6	9.99	8.05	17.9	10.1	13.13	7.61	23.6	16.3	16.62	7.17	29.8	24.8	
27		7.14	7.14	12.8	5.6	9.97	8.70	17.9	10.1	13.11	8.25	23.5	16.3	16.59	7.81	29.8	24.7	
28		7.12	7.12	12.8	5.6	9.95	9.34	17.8	10.0	13.08	8.90	23.5	16.2	16.57	8.46	29.7	24.6	
29		7.10	7.10	12.7	5.6	9.93	9.93	17.8	10.0	13.06	9.55	23.4	16.2	16.54	9.10	29.7	24.6	
30	7.08	7.08	12.7	5.5	9.90	10.58	17.8	9.9	13.04	10.19	23.4	16.1	16.52	9.75	29.6	24.5		

Note

1. TC : Total capacity, SHC : Sensible Heat Capacity
2. Performances are based on the following conditions :
 - 1) Cooling
 - Condition A : Inlet/Outlet Water Temp. 7°C / 12°C, Indoor Air Temp. 27°CDB / 19°CWB
 - Condition B : Inlet/Outlet Water Temp. 10°C / 15°C, Indoor Air Temp. 27°CDB / 19°CWB
 - Condition C : Inlet/Outlet Water Temp. 7°C / 12°C, Indoor Air Temp. 25°CDB / 17.9°CWB
 - Condition D : Inlet/Outlet Water Temp. 14°C / 18°C, Indoor Air Temp. 26°CDB / 18°CWB
3. Above capacity tables shows representative values according to the change in temperature or water flow rate, etc., it may vary depending on the installation conditions and the surrounding environment.

6. Capacity Tables

Inlet Water Temp. (°C)	Water Temp Difference (°C)	Air Temp (°C DB)	Air Temp(17°C WB)				Air Temp(19°C WB)				Air Temp(21°C WB)				Air Temp(23°C WB)			
			TC (kW)	SHC (kW)	Water Flow Rate (LPM)	Pressure Drop (kPa)	TC (kW)	SHC (kW)	Water Flow Rate (LPM)	Pressure Drop (kPa)	TC (kW)	SHC (kW)	Water Flow Rate (LPM)	Pressure Drop (kPa)	TC (kW)	SHC (kW)	Water Flow Rate (LPM)	Pressure Drop (kPa)
9	4	24	8.84	8.43	31.7	29.8	12.00	7.90	43.1	51.3	15.50	7.37	55.6	81.2	19.40	6.84	69.6	121.5
		25	8.82	8.82	31.6	29.7	11.97	8.63	43.0	51.1	15.48	8.10	55.5	81.0	19.37	7.57	69.5	121.2
		26	8.80	8.80	31.6	29.6	11.95	9.36	42.9	51.0	15.45	8.83	55.4	80.7	19.34	8.30	69.4	120.9
		27	8.78	8.78	31.5	29.4	11.93	10.09	42.8	50.8	15.42	9.56	55.4	80.5	19.31	9.04	69.3	120.5
		28	8.76	8.76	31.4	29.3	11.90	10.82	42.7	50.6	15.40	10.30	55.3	80.2	19.28	9.77	69.2	120.2
		29	8.74	8.74	31.3	29.2	11.88	11.55	42.6	50.4	15.37	11.03	55.2	80.0	19.25	10.50	69.1	119.9
	30	8.71	8.71	31.3	29.1	11.86	11.86	42.5	50.3	15.35	11.76	55.1	79.7	19.23	11.23	69.0	119.6	
	5	24	8.61	8.34	24.7	19.2	11.76	7.81	33.8	33.3	15.26	7.28	43.8	53.0	19.15	6.75	55.0	79.5
		25	8.59	8.59	24.7	19.1	11.74	8.54	33.7	33.2	15.24	8.01	43.7	52.8	19.12	7.48	54.9	79.3
		26	8.57	8.57	24.6	19.0	11.71	9.27	33.6	33.1	15.21	8.74	43.7	52.6	19.09	8.21	54.8	79.1
		27	8.55	8.55	24.5	18.9	11.69	10.00	33.6	32.9	15.18	9.47	43.6	52.5	19.06	8.94	54.7	78.8
		28	8.53	8.53	24.5	18.8	11.67	10.73	33.5	32.8	15.16	10.20	43.5	52.3	19.03	9.68	54.6	78.6
		29	8.51	8.51	24.4	18.8	11.64	11.46	33.4	32.7	15.13	10.94	43.4	52.1	19.01	10.41	54.6	78.4
	6	24	8.49	8.49	24.4	18.7	11.62	11.62	33.4	32.6	15.10	11.67	43.4	52.0	18.98	11.14	54.5	78.2
		25	8.38	8.25	20.0	13.2	11.52	7.72	27.6	23.2	15.02	7.19	35.9	37.2	18.90	6.66	45.2	56.0
		26	8.36	8.36	20.0	13.2	11.50	8.45	27.5	23.2	14.99	7.92	35.9	37.1	18.87	7.39	45.2	55.9
		27	8.34	8.34	19.9	13.1	11.48	9.18	27.5	23.1	14.97	8.65	35.8	37.0	18.84	8.12	45.1	55.7
		28	8.32	8.32	19.9	13.1	11.45	9.91	27.4	23.0	14.94	9.38	35.7	36.8	18.81	8.85	45.0	55.6
		29	8.30	8.30	19.8	13.0	11.43	10.64	27.3	22.9	14.91	10.11	35.7	36.7	18.78	9.59	44.9	55.4
	7	24	8.28	8.28	19.8	13.0	11.41	11.41	27.3	22.8	14.89	10.84	35.6	36.6	18.76	10.32	44.9	55.3
		25	8.25	8.25	19.7	12.9	11.38	11.38	27.2	22.7	14.86	11.58	35.6	36.5	18.73	11.05	44.8	55.1
		26	8.15	8.15	16.7	9.6	11.29	7.63	23.1	17.1	14.77	7.10	30.3	27.5	18.65	6.57	38.2	41.6
		27	8.13	8.13	16.7	9.6	11.26	8.36	23.1	17.0	14.75	7.83	30.2	27.4	18.62	7.30	38.2	41.4
		28	8.11	8.11	16.6	9.5	11.24	9.09	23.0	16.9	14.72	8.56	30.2	27.3	18.59	8.03	38.1	41.3
		29	8.09	8.09	16.6	9.5	11.22	9.82	23.0	16.9	14.69	9.29	30.1	27.2	18.56	8.76	38.1	41.2
	8	24	8.06	8.06	16.5	9.5	11.19	10.55	23.0	16.8	14.67	10.02	30.1	27.1	18.53	9.49	38.0	41.1
		25	8.04	8.04	16.5	9.4	11.17	11.17	22.9	16.8	14.64	10.75	30.0	27.0	18.50	10.23	37.9	41.0
		26	8.02	8.02	16.5	9.4	11.15	11.15	22.9	16.7	14.62	11.49	30.0	26.9	18.47	10.96	37.9	40.9
		27	7.92	7.92	14.2	7.2	11.05	7.54	19.8	13.0	14.53	7.01	26.1	21.0	18.40	6.48	33.0	32.0
		28	7.89	7.89	14.2	7.2	11.02	8.27	19.8	12.9	14.50	7.74	26.0	21.0	18.37	7.21	33.0	31.9
29		7.87	7.87	14.1	7.2	11.00	9.00	19.7	12.9	14.47	8.47	26.0	20.9	18.34	7.94	32.9	31.8	
9	8	27	7.85	7.85	14.1	7.1	10.98	9.73	19.7	12.8	14.45	9.20	25.9	20.8	18.31	8.67	32.9	31.7
		28	7.83	7.83	14.1	7.1	10.95	10.46	19.7	12.8	14.42	9.93	25.9	20.8	18.28	9.40	32.8	31.6
		29	7.81	7.81	14.0	7.1	10.93	10.93	19.6	12.7	14.40	10.66	25.8	20.7	18.25	10.14	32.8	31.5
30	7.79	7.79	14.0	7.0	10.91	10.91	19.6	12.7	14.37	11.39	25.8	20.6	18.22	10.87	32.7	31.5		

Note

- TC : Total capacity, SHC : Sensible Heat Capacity
- Performances are based on the following conditions :
 - Cooling
 - Condition A : Inlet/Outlet Water Temp. 7°C / 12°C, Indoor Air Temp. 27°CDB / 19°CWB
 - Condition B : Inlet/Outlet Water Temp. 10°C / 15°C, Indoor Air Temp. 27°CDB / 19°CWB
 - Condition C : Inlet/Outlet Water Temp. 7°C / 12°C, Indoor Air Temp. 25°CDB / 17.9°CWB
 - Condition D : Inlet/Outlet Water Temp. 14°C / 18°C, Indoor Air Temp. 26°CDB / 18°CWB
- Above capacity tables shows representative values according to the change in temperature or water flow rate, etc., it may vary depending on the installation conditions and the surrounding environment.

6. Capacity Tables

6.2 Heating Capacity

◆ WFCB056-

Water Temp Difference (°C)	Air Temp (°C DB)	Inlet Water Temp.(°C)														
		40			45			50			55			60		
		TC (kW)	Water Flow Rate (LPM)	Pressure Drop (kPa)	TC (kW)	Water Flow Rate (LPM)	Pressure Drop (kPa)	TC (kW)	Water Flow Rate (LPM)	Pressure Drop (kPa)	TC (kW)	Water Flow Rate (LPM)	Pressure Drop (kPa)	TC (kW)	Water Flow Rate (LPM)	Pressure Drop (kPa)
4	16	6.28	22.5	28.3	7.64	27.4	40.0	8.99	32.3	53.4	10.35	37.1	68.5	11.70	42.0	85.3
	18	5.74	20.6	24.2	7.10	25.5	35.1	8.45	30.3	47.8	9.80	35.2	62.3	11.16	40.0	78.4
	20	5.20	18.7	20.3	6.55	23.5	30.5	7.91	28.4	42.5	9.26	33.2	56.3	10.62	38.1	71.7
	22	4.66	16.7	16.7	6.01	21.6	26.2	7.37	26.4	37.5	8.72	31.3	50.6	10.08	36.2	65.3
5	16	6.23	17.9	18.8	7.58	21.8	26.6	8.94	25.7	35.6	10.29	29.5	45.7	11.65	33.4	56.9
	18	5.69	16.3	16.1	7.04	20.2	23.4	8.40	24.1	31.9	9.75	28.0	41.5	11.10	31.9	52.2
	20	5.15	14.8	13.5	6.50	18.7	20.3	7.85	22.5	28.3	9.21	26.4	37.5	10.56	30.3	47.8
	22	4.60	13.2	11.1	5.96	17.1	17.4	7.31	21.0	25.0	8.67	24.9	33.7	10.02	28.8	43.6
6	16	6.18	14.8	13.5	7.53	18.0	19.1	8.88	21.3	25.5	10.24	24.5	32.8	11.59	27.7	40.8
	18	5.63	13.5	11.5	6.99	16.7	16.7	8.34	20.0	22.8	9.70	23.2	29.8	11.05	26.4	37.5
	20	5.09	12.2	9.6	6.45	15.4	14.5	7.80	18.7	20.3	9.15	21.9	26.9	10.51	25.1	34.3
	22	4.55	10.9	7.9	5.90	14.1	12.5	7.26	17.4	17.9	8.61	20.6	24.2	9.97	23.8	31.3
7	16	6.12	12.6	10.1	7.48	15.3	14.4	8.83	18.1	19.3	10.18	20.9	24.7	11.54	23.7	30.8
	18	5.58	11.4	8.6	6.93	14.2	12.6	8.29	17.0	17.2	9.64	19.8	22.5	11.00	22.5	28.3
	20	5.04	10.3	7.2	6.39	13.1	10.9	7.75	15.9	15.3	9.10	18.7	20.3	10.45	21.4	25.9
	22	4.50	9.2	5.9	5.85	12.0	9.4	7.20	14.8	13.5	8.56	17.5	18.2	9.91	20.3	23.6
8	16	6.07	10.9	7.9	7.42	13.3	11.2	8.78	15.7	15.1	10.13	18.2	19.4	11.48	20.6	24.2
	18	5.53	9.9	6.7	6.88	12.3	9.9	8.23	14.8	13.5	9.59	17.2	17.6	10.94	19.6	22.2
	20	4.98	8.9	5.6	6.34	11.4	8.5	7.69	13.8	12.0	9.05	16.2	15.9	10.40	18.7	20.3
	22	4.44	8.0	4.6	5.80	10.4	7.3	7.15	12.8	10.5	8.50	15.3	14.3	9.86	17.7	18.5
24	3.90	7.0	3.7	5.25	9.4	6.2	6.61	11.9	9.2	7.96	14.3	12.7	9.32	16.7	16.7	

Note

- TC : Total capacity
- Performances are based on the following conditions :
 - Heating
 - Condition A : Inlet/Outlet Water Temp. 45°C / 40°C, Indoor Air Temp. 20°CDB / 15°CWB
 - Condition B : Inlet Water Temp. 50°C, Indoor Air Temp. 20°CDB / 15°CWB
- Above capacity tables shows representative values according to the change in temperature or water flow rate, etc., it may vary depending on the installation conditions and the surrounding environment.

◆ WFCB066-

Water Temp Difference (°C)	Air Temp (°C DB)	Inlet Water Temp.(°C)														
		40			45			50			55			60		
		TC (kW)	Water Flow Rate (LPM)	Pressure Drop (kPa)	TC (kW)	Water Flow Rate (LPM)	Pressure Drop (kPa)	TC (kW)	Water Flow Rate (LPM)	Pressure Drop (kPa)	TC (kW)	Water Flow Rate (LPM)	Pressure Drop (kPa)	TC (kW)	Water Flow Rate (LPM)	Pressure Drop (kPa)
4	16	7.54	27.1	39.2	9.17	32.9	55.5	10.79	38.7	74.2	12.42	44.6	95.2	14.04	50.4	118.7
	18	6.89	24.7	33.5	8.52	30.6	48.7	10.14	36.4	66.4	11.77	42.2	86.5	13.39	48.1	109.0
	20	6.24	22.4	28.1	7.87	28.2	42.3	9.49	34.1	59.0	11.12	39.9	78.2	12.74	45.7	99.7
	22	5.59	20.1	23.2	7.22	25.9	36.3	8.84	31.7	52.0	10.47	37.6	70.2	12.09	43.4	90.8
5	16	7.48	21.5	26.1	9.10	26.1	36.9	10.73	30.8	49.3	12.35	35.5	63.4	13.98	40.1	79.0
	18	6.83	19.6	22.2	8.45	24.3	32.4	10.08	28.9	44.2	11.70	33.6	57.6	13.33	38.3	72.6
	20	6.18	17.7	18.6	7.80	22.4	28.1	9.43	27.1	39.2	11.05	31.7	52.0	12.68	36.4	66.4
	22	5.53	15.9	15.3	7.15	20.5	24.1	8.78	25.2	34.6	10.40	29.9	46.7	12.03	34.5	60.5
6	16	7.41	17.7	18.6	9.04	21.6	26.4	10.66	25.5	35.3	12.29	29.4	45.4	13.91	33.3	56.6
	18	6.76	16.2	15.9	8.39	20.1	23.2	10.01	23.9	31.6	11.64	27.8	41.3	13.26	31.7	52.0
	20	6.11	14.6	13.3	7.74	18.5	20.1	9.36	22.4	28.1	10.99	26.3	37.3	12.61	30.2	47.6
	22	5.46	13.1	10.9	7.09	16.9	17.2	8.71	20.8	24.8	10.34	24.7	33.5	11.96	28.6	43.3
7	16	7.35	15.1	14.0	8.97	18.4	19.9	10.60	21.7	26.6	12.22	25.1	34.3	13.85	28.4	42.7
	18	6.70	13.7	11.9	8.32	17.1	17.4	9.95	20.4	23.8	11.57	23.7	31.1	13.20	27.1	39.2
	20	6.05	12.4	10.0	7.67	15.7	15.1	9.30	19.1	21.2	10.92	22.4	28.1	12.55	25.7	35.9
	22	5.40	11.1	8.2	7.02	14.4	12.9	8.65	17.7	18.6	10.27	21.1	25.2	11.90	24.4	32.7
8	16	7.28	13.1	10.9	8.91	16.0	15.5	10.53	18.9	20.8	12.16	21.8	26.8	13.78	24.7	33.5
	18	6.63	11.9	9.3	8.26	14.8	13.6	9.88	17.7	18.6	11.51	20.6	24.3	13.13	23.6	30.7
	20	5.98	10.7	7.8	7.61	13.6	11.8	9.23	16.6	16.5	10.86	19.5	22.0	12.48	22.4	28.1
	22	5.33	9.6	6.4	6.96	12.5	10.1	8.58	15.4	14.6	10.21	18.3	19.7	11.83	21.2	25.6
24	4.68	8.4	5.1	6.31	11.3	8.5	7.93	14.2	12.7	9.56	17.1	17.6	11.18	20.1	23.2	

Note

- TC : Total capacity
- Performances are based on the following conditions :
 - Heating
 - Condition A : Inlet/Outlet Water Temp. 45°C / 40°C, Indoor Air Temp. 20°CDB / 15°CWB
 - Condition B : Inlet Water Temp. 50°C, Indoor Air Temp. 20°CDB / 15°CWB
- Above capacity tables shows representative values according to the change in temperature or water flow rate, etc., it may vary depending on the installation conditions and the surrounding environment.

6. Capacity Tables

◆ WFCB140-

Water Temp Difference (°C)	Air Temp (°C DB)	Inlet Water Temp.(°C)														
		40			45			50			55			60		
		TC (kW)	Water Flow Rate (LPM)	Pressure Drop (kPa)	TC (kW)	Water Flow Rate (LPM)	Pressure Drop (kPa)	TC (kW)	Water Flow Rate (LPM)	Pressure Drop (kPa)	TC (kW)	Water Flow Rate (LPM)	Pressure Drop (kPa)	TC (kW)	Water Flow Rate (LPM)	Pressure Drop (kPa)
4	16	16.05	57.6	99.2	19.51	70.0	141.0	22.96	82.4	189.2	26.42	94.8	244.0	-	-	-
	18	14.66	52.6	84.4	18.12	65.0	123.5	21.58	77.4	169.2	25.04	89.9	221.3	-	-	-
	20	13.28	47.7	70.7	16.74	60.1	107.0	20.20	72.5	150.1	23.66	84.9	199.7	-	-	-
	22	11.90	42.7	58.1	15.36	55.1	91.7	18.81	67.5	132.1	22.27	79.9	179.1	25.73	92.3	232.5
	24	10.51	37.7	46.6	13.97	50.1	77.4	17.43	62.5	115.1	20.89	75.0	159.5	24.35	87.4	210.4
5	16	15.91	45.7	65.5	19.37	55.6	93.2	22.83	65.5	125.2	26.28	75.5	161.4	29.74	85.4	201.8
	18	14.53	41.7	55.7	17.98	51.6	81.6	21.44	61.6	111.9	24.90	71.5	146.4	28.36	81.4	185.1
	20	13.14	37.7	46.6	16.60	47.7	70.7	20.06	57.6	99.2	23.52	67.5	132.1	26.98	77.4	169.2
	22	11.76	33.8	38.2	15.22	43.7	60.5	18.68	53.6	87.3	22.13	63.5	118.4	25.59	73.5	153.8
	24	10.38	29.8	30.6	13.83	39.7	51.1	17.29	49.6	76.1	20.75	59.6	105.5	24.21	69.5	139.2
6	16	15.77	37.7	46.6	19.23	46.0	66.4	22.69	54.3	89.2	26.15	62.5	115.1	29.60	70.8	144.0
	18	14.39	34.4	39.6	17.85	42.7	58.1	21.30	51.0	79.7	24.76	59.2	104.4	28.22	67.5	132.1
	20	13.00	31.1	33.1	16.46	39.4	50.3	19.92	47.7	70.7	23.38	55.9	94.2	26.84	64.2	120.7
	22	11.62	27.8	27.1	15.08	36.1	43.0	18.54	44.3	62.2	22.00	52.6	84.4	25.45	60.9	109.7
	24	10.24	24.5	21.7	13.70	32.8	36.3	17.15	41.0	54.1	20.61	49.3	75.2	24.07	57.6	99.2
7	16	15.63	32.1	34.9	19.09	39.1	49.8	22.55	46.2	67.0	26.01	53.3	86.5	29.47	60.4	108.2
	18	14.25	29.2	29.6	17.71	36.3	43.5	21.17	43.4	59.8	24.62	50.5	78.4	28.08	57.6	99.2
	20	12.87	26.4	24.7	16.32	33.5	37.7	19.78	40.6	53.0	23.24	47.7	70.7	26.70	54.7	90.6
	22	11.48	23.5	20.2	14.94	30.6	32.2	18.40	37.7	46.6	21.86	44.8	63.4	25.32	51.9	82.4
	24	10.10	20.7	16.1	13.56	27.8	27.1	17.02	34.9	40.5	20.47	42.0	56.4	23.93	49.1	74.5
8	16	15.49	27.8	27.1	18.95	34.0	38.7	22.41	40.2	52.2	25.87	46.4	67.4	29.33	52.6	84.4
	18	14.11	25.3	23.0	17.57	31.5	33.9	21.03	37.7	46.6	24.49	43.9	61.1	27.94	50.1	77.4
	20	12.73	22.8	19.1	16.19	29.0	29.3	19.64	35.2	41.3	23.10	41.5	55.1	26.56	47.7	70.7
	22	11.34	20.4	15.6	14.80	26.6	25.0	18.26	32.8	36.3	21.72	39.0	49.4	25.18	45.2	64.3
	24	9.96	17.9	12.4	13.42	24.1	21.0	16.88	30.3	31.5	20.34	36.5	43.9	23.79	42.7	58.1

Note

1. TC : Total capacity
2. Performances are based on the following conditions :
 - 1) Heating
 - Condition A : Inlet/Outlet Water Temp. 45°C / 40°C, Indoor Air Temp. 20°CDB / 15°CWB
 - Condition B : Inlet Water Temp. 50°C, Indoor Air Temp. 20°CDB / 15°CWB
3. Above capacity tables shows representative values according to the change in temperature or water flow rate, etc., it may vary depending on the installation conditions and the surrounding environment.

7. External Static Pressure (E.S.P) & Air Flow

◆ WFCB056RG0A, WFCB056LG0A

Setting Value	Static Pressure(mmAq(Pa))							
	2.5	4	6	8	10	12	14	15
	Air Flow Rate (m³/min)							
85	13.31	10.89	-	-	-	-	-	-
90	14.91	12.44	-	-	-	-	-	-
95	16.28	14.23	11.16	-	-	-	-	-
100	17.49	15.83	12.62	8.73	-	-	-	-
105	19.07	17.22	14.79	10.99	6.19	-	-	-
110	20.50	18.93	16.50	13.63	9.14	-	-	-
115	21.66	20.39	17.96	15.58	11.84	6.80	-	-
120	22.97	21.52	19.28	17.36	14.57	10.12	6.18	-
125	-	22.81	21.12	18.96	16.20	13.44	7.91	6.49
130	-	-	22.42	20.68	18.10	15.35	11.58	8.36
135	-	-	-	21.98	20.24	17.57	14.66	12.71
140	-	-	-	-	21.55	19.62	17.38	16.01

Note

1. The above table shows the correlation between the air rates and E.S.P.
2. The above table shows the available E.S.P. range.
3. If the E.S.P. of the installed indoor is less than the lowest value(as mention in the table), indoor components can be failed.

◆ Fan Performance (WFCB056RG0A, WFCB056LG0A)

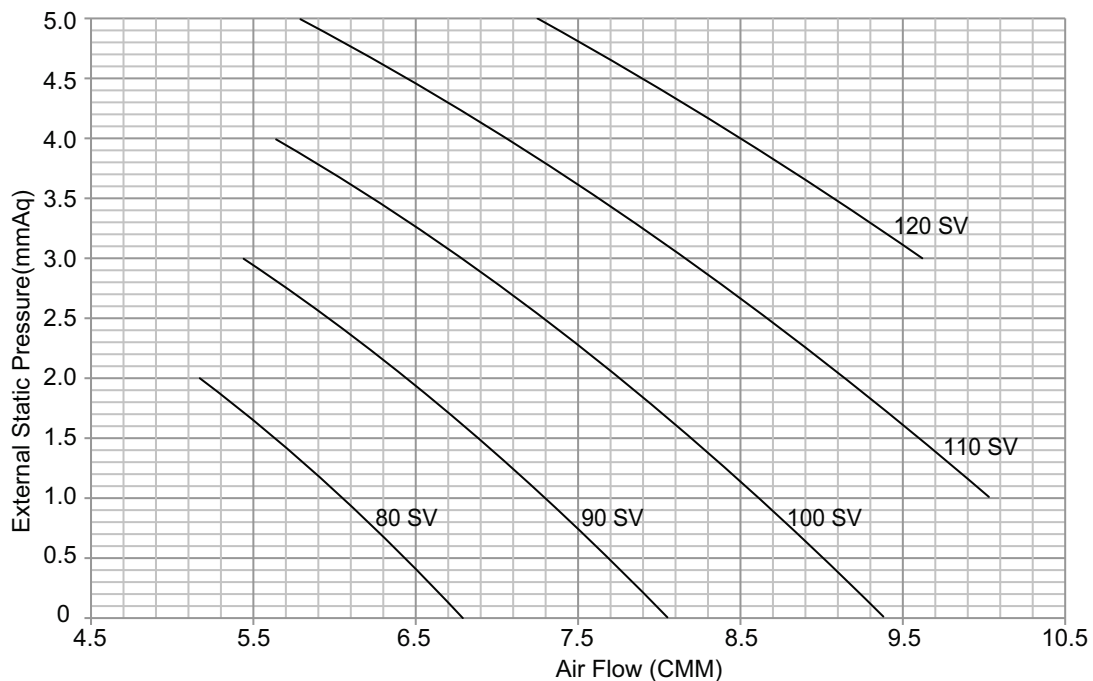

7. External Static Pressure (E.S.P) & Air Flow

◆ WFCB066RG0A, WFCB066LG0A WFCB090RG0A, WFCB090LG0A, WFCB100RG0A, WFCB100LG0A WFCB109RG0A, WFCB109LG0A

Setting Value	Static Pressure(mmAq(Pa))						
	5	6	8	10	12	14	15
	Air Flow Rate (m ³ /min)						
90	18.67	-	-	-	-	-	-
95	21.66	17.51	-	-	-	-	-
100	24.94	22.14	-	-	-	-	-
105	27.31	25.44	18.08	-	-	-	-
110	30.32	28.15	23.08	-	-	-	-
115	32.80	30.98	26.49	18.62	-	-	-
120	35.63	33.78	29.76	24.43	16.78	-	-
125	37.96	36.44	32.96	28.05	21.01	-	-
130	-	39.22	35.62	31.70	26.63	18.39	-
135	-	-	38.22	35.13	30.29	22.61	19.96
140	-	-	-	37.90	34.33	27.30	25.05
145	-	-	-	-	37.30	32.38	30.20
150	-	-	-	-	-	36.34	34.40
155	-	-	-	-	-	-	36.98

Note

1. The above table shows the correlation between the air rates and E.S.P.
2. The above table shows the available E.S.P. range.
3. If the E.S.P. of the installed indoor is less than the lowest value(as mention in the table), indoor components can be failed.

◆ Fan Performance

WFCB066RG0A, WFCB066LG0A WFCB090RG0A, WFCB090LG0A, WFCB100RG0A, WFCB100LG0A WFCB109RG0A, WFCB109LG0A

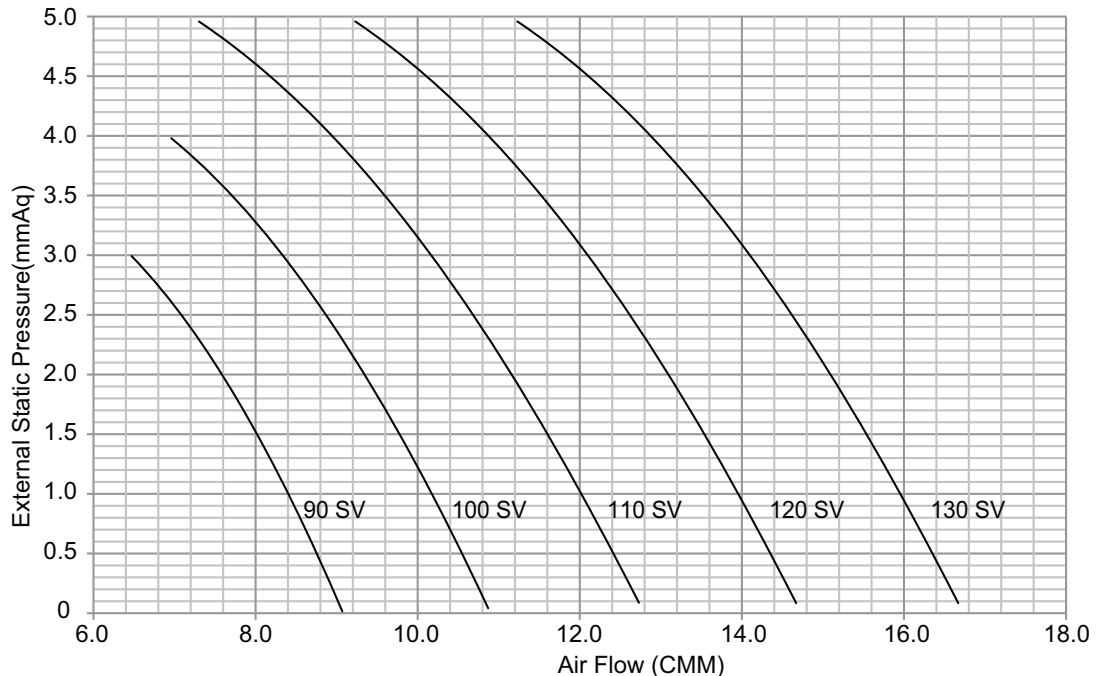

7. External Static Pressure (E.S.P) & Air Flow

◆ WFCB127RG0A, WFCB127LG0A, WFCB140RG0A, WFCB140LG0A

Setting Value	Static Pressure(mmAq(Pa))						
	5	6	8	10	12	14	15
	Air Flow Rate (m³/min)						
70	17.09	-	-	-	-	-	-
75	22.13	18.77	-	-	-	-	-
80	26.83	22.94	16.16	-	-	-	-
85	30.96	28.96	21.76	13.29	-	-	-
90	35.77	32.89	28.46	19.76	13.06	-	-
95	40.27	37.84	33.53	24.96	16.88	12.35	-
100	44.11	41.51	38.08	33.20	25.34	17.08	13.72
105	47.73	46.09	43.50	38.04	31.58	24.04	19.24
110	-	49.83	47.42	42.57	37.68	30.00	27.25
115	-	-	52.82	47.52	42.40	38.28	33.79
120	-	-	-	52.89	47.84	43.84	40.81
125	-	-	-	-	49.69	44.06	42.25

Note

1. The above table shows the correlation between the air rates and E.S.P.
2. The above table shows the available E.S.P. range.
3. If the E.S.P. of the installed indoor is less than the lowest value(as mention in the table), indoor components can be failed.

◆ Fan Performance (WFCB127RG0A, WFCB127LG0A, WFCB140RG0A, WFCB140LG0A)

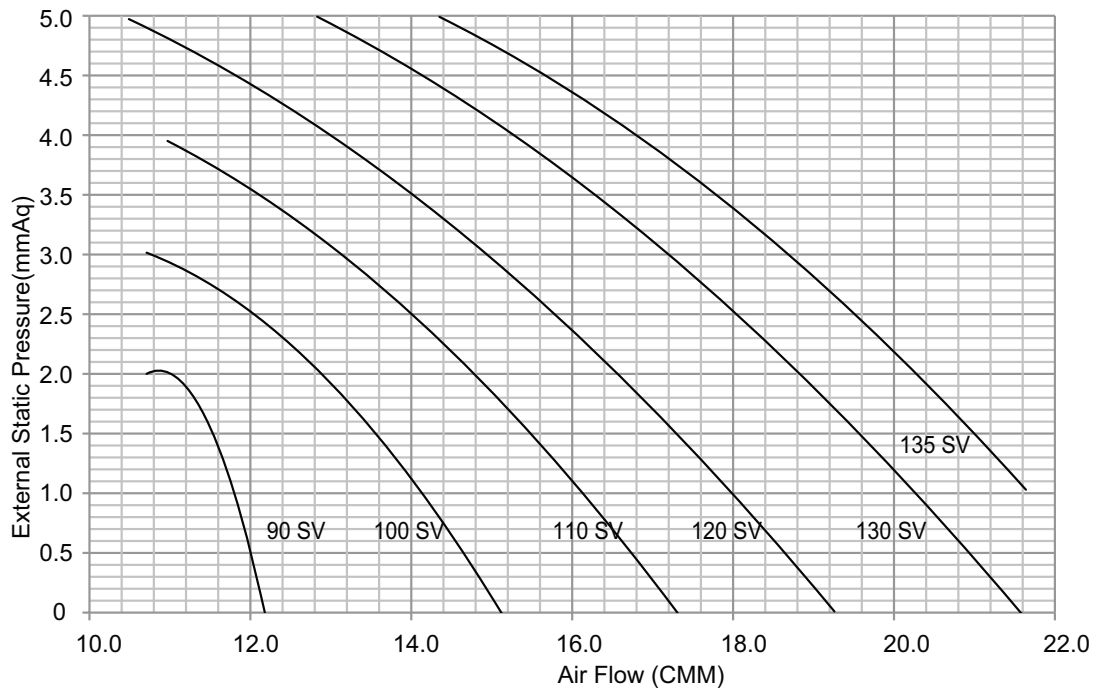

8. Electric Characteristics

Unit					Power Supply	IFM		PI	
Model	Type	Hz	Volts	Voltage Range	MCA	kW	FLA	cooling	Heating
WFCB056LG0A	M1	50	220-240	Max : 264 Min : 198	1.04	0.136	0.83	102	102
WFCB056RG0A	M1				1.04	0.136	0.83	102	102
WFCB066LG0A	M1				1.44	0.136	1.15	143	143
WFCB066RG0A	M1				1.44	0.136	1.15	143	143
WFCB090LG0A	M2				1.38	0.350	1.10	136	136
WFCB090RG0A	M2				1.38	0.350	1.10	136	136
WFCB100LG0A	M2				1.89	0.350	1.51	189	189
WFCB100RG0A	M2				1.89	0.350	1.51	189	189
WFCB109LG0A	M2				2.30	0.350	1.84	233	233
WFCB109RG0A	M2				2.30	0.350	1.84	233	233
WFCB127LG0A	M3				1.95	0.400	1.56	217	217
WFCB127RG0A	M3				1.95	0.400	1.56	217	217
WFCB140LG0A	M3				2.38	0.400	1.90	266	266
WFCB140RG0A	M3				2.38	0.400	1.90	266	266
WFCB056LG0A	M1	60	220	Max : 242 Min : 198	1.04	0.136	0.83	102	102
WFCB056RG0A	M1				1.04	0.136	0.83	102	102
WFCB066LG0A	M1				1.44	0.136	1.15	143	143
WFCB066RG0A	M1				1.44	0.136	1.15	143	143
WFCB090LG0A	M2				1.38	0.350	1.10	136	136
WFCB090RG0A	M2				1.38	0.350	1.10	136	136
WFCB100LG0A	M2				1.89	0.350	1.51	189	189
WFCB100RG0A	M2				1.89	0.350	1.51	189	189
WFCB109LG0A	M2				2.30	0.350	1.84	233	233
WFCB109RG0A	M2				2.30	0.350	1.84	233	233
WFCB127LG0A	M3				1.95	0.400	1.56	217	217
WFCB127RG0A	M3				1.95	0.400	1.56	217	217
WFCB140LG0A	M3				2.38	0.400	1.90	266	266
WFCB140RG0A	M3				2.38	0.400	1.90	266	266

Symbols
MCA : Minimum Circuit Amperes (A)
kW : Fan Motor Rated Output (kW)
FLA : Full Load Amperes (A)
IFM : Indoor Fan Motor
PI : Maximum Power Input (W)

Note

- Voltage range
Units are suitable for use on electrical systems where voltage supplied to unit terminals is not below or above the listed range limits.
- Maximum allowable voltage unbalance between phases is 2%.
- MCA/MFA
 $MCA = 1.25 \times FLA$
 $MFA = 1.1 \times MCA, MFA \leq 4 \times FLA$
 (If MFA is smaller than minimum standard value, Use minimum standard value in region for selecting circuit breaker.)
- Select wire size based on the MCA
- Instead of fuse, use Circuit Breaker.

9. Sound Levels

9.1 Sound Pressure Levels

Overall

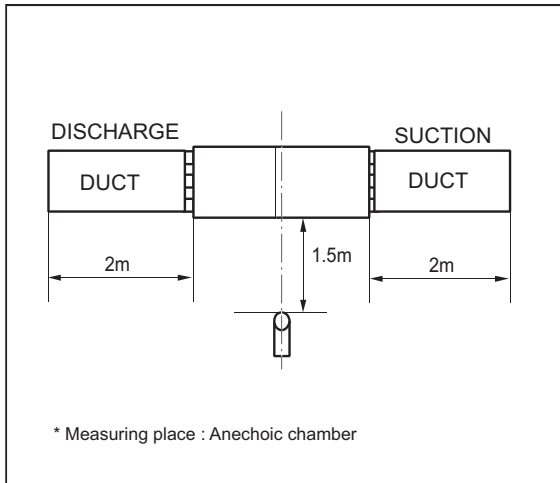

Note

1. Sound measured at some distance away from the center of the unit.
2. Data is valid at free field condition.
3. Reference acoustic pressure 0dB = 20μPa.
4. Data is valid at nominal operation condition.
Refer to the Model Specifications for nominal conditions (Power source and Ambient temperature, etc)
5. Sound levels can be increased in accordance with installation and operating conditions. (Static pressure mode, used air guide, Room target temperature setting, etc)
6. Sound level will vary depending on a range of factors such as the construction (acoustic absorption coefficient) of particular room in which the equipment is installed.
7. Sound pressure level is measured on the rated condition in the anechoic rooms by ISO 3745 standard.
Therefore, these values can be increased owing to ambient conditions during operation.

Model	Sound Pressure Levels [dB(A)]		
	H	M	L
WFCB056LG0A / WFCB056RG0A	43	41	39
WFCB066LG0A / WFCB066RG0A	45	43	41
WFCB090LG0A / WFCB090RG0A	46	44	43
WFCB100LG0A / WFCB100RG0A	47	46	44
WFCB109LG0A / WFCB109RG0A	48	47	46
WFCB127LG0A / WFCB127RG0A	49	48	47
WFCB140LG0A / WFCB140RG0A	50	49	48

WFCB056LG0A, WFCB056RG0A

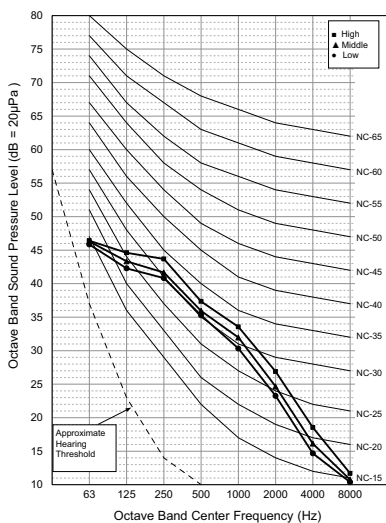

WFCB066LG0A, WFCB066RG0A

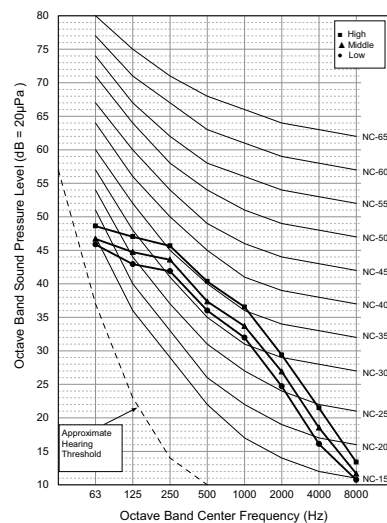

WFCB090LG0A, WFCB090RG0A

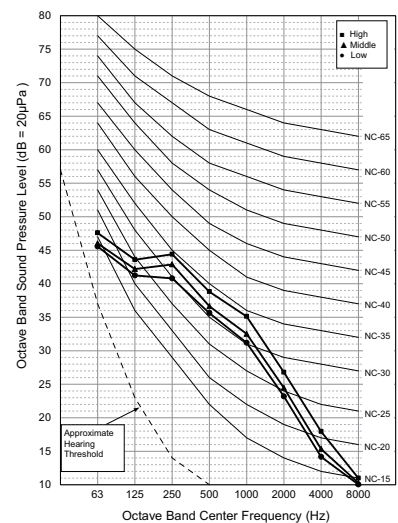

9. Sound Levels

WFCB100LG0A,WFCB100RG0A

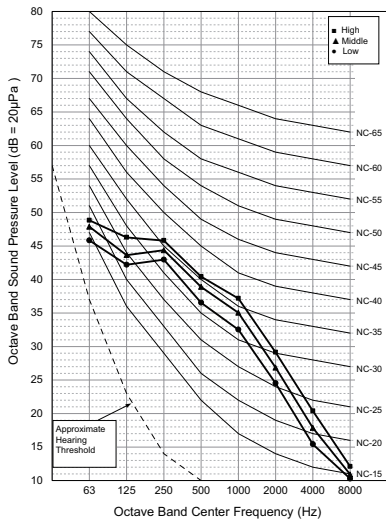

WFCB109LG0A,WFCB109RG0A

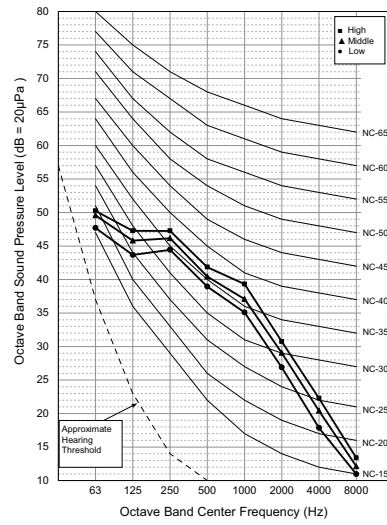

WFCB127LG0A,WFCB127RG0A

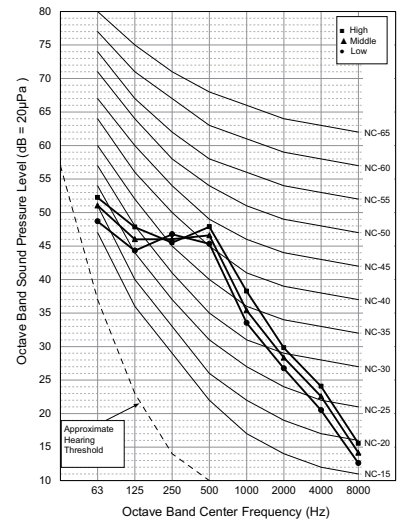

WFCB140LG0A,WFCB140RG0A

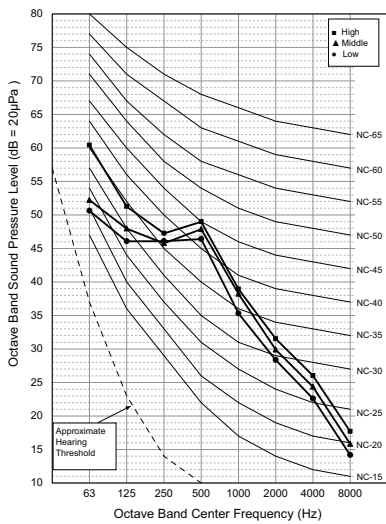

9. Sound Levels

9.2 Sound Power Levels

Note

- Data is valid at diffuse field condition
- Data is valid at nominal operating condition
- Sound level can be increased in static pressure mode or used air guide.
- Sound level will vary depending on a range of factors such as the construction (acoustic absorption coefficient) of particular room in which the equipment is installed.
- Reference acoustic intensity 0dB = $10E-6\mu W/m^2$
- Sound power level is measured on the rated condition in the semi-anechoic rooms by ISO 9614 standard. Therefore, these values can be increased owing to ambient conditions during operation.

Model	Sound Power Levels [dB(A)]		
	H	M	L
WFCB056LG0A / WFCB056RG0A	61	58	57
WFCB066LG0A / WFCB066RG0A	63	61	58
WFCB090LG0A / WFCB090RG0A	59	58	57
WFCB100LG0A / WFCB100RG0A	61	59	58
WFCB109LG0A / WFCB109RG0A	63	61	59
WFCB127LG0A / WFCB127RG0A	64	63	62
WFCB140LG0A / WFCB140RG0A	65	64	63

WFCB056LG0A,WFCB056RG0A

WFCB066LG0A,WFCB066RG0A

WFCB090LG0A,WFCB090RG0A

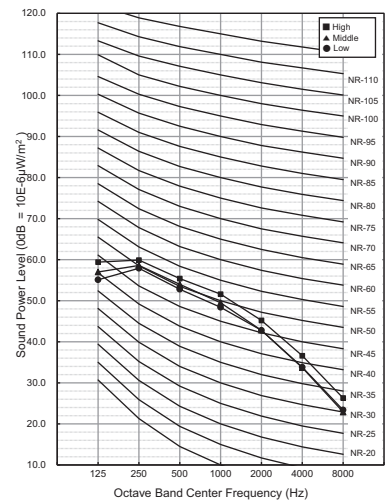
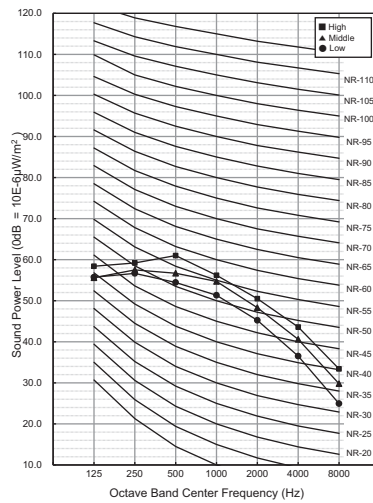
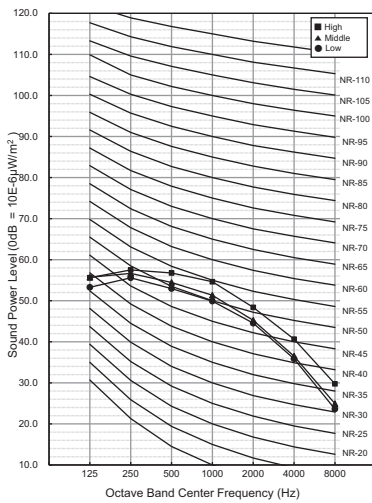

9. Sound Levels

WFCB100LG0A,WFCB100RG0A

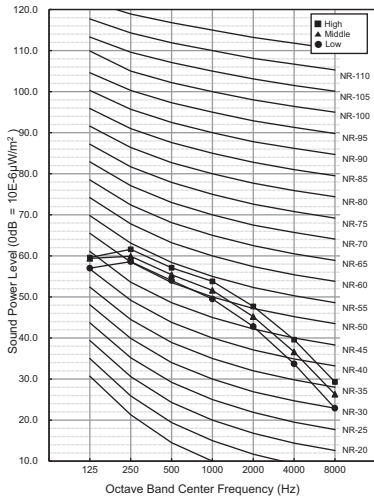

WFCB109LG0A,WFCB109RG0A

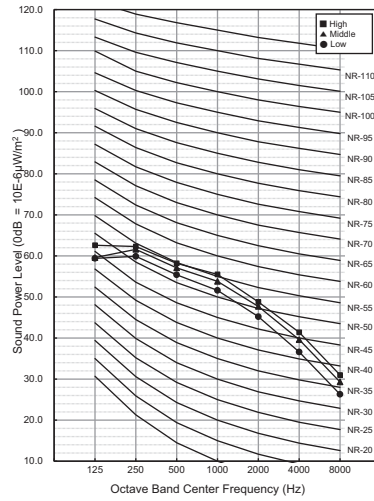

WFCB127LG0A,WFCB127RG0A

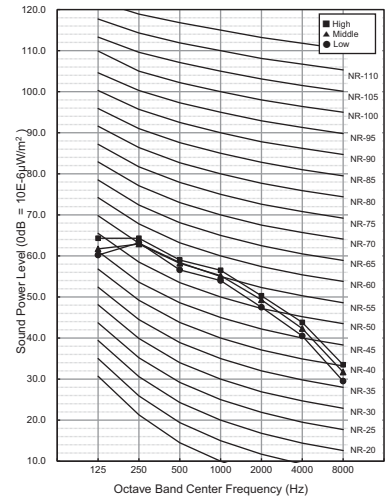

WFCB140LG0A,WFCB140RG0A

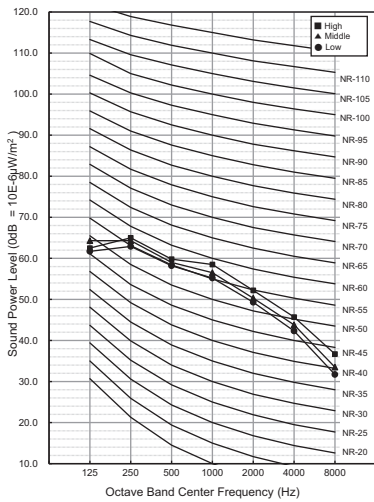

FCU

Ceiling Concealed Duct (Low Static)

- 1. List of functions**
- 2. Specifications**
- 3. Dimensions**
- 4. Piping Diagrams**
- 5. Wiring Diagrams**
- 6. Capacity Tables**
- 7. External Static Pressure**
- 8. Electric Characteristics**
- 9. Sound Levels**

1. List of Functions

◆ List of Functions

Category	Function	WFC A012RG0A, WFC A018RG0A, WFC A025RG0A WFC A032RG0A, WFC A039RG0A, WFC A055RG0A, WFC A066RG0A
Air flow	Air supply outlet	1
	Airflow direction control(left & right)	-
	Airflow direction control(up & down)	-
	Auto swing(left & right)	-
	Auto swing(up & down)	-
	Airflow steps(fan/cool/heat)	3 / 3 / 3
	Chaos swing	-
	Chaos wind(auto wind)	-
	Jet cool(Power wind)	-
Swirl wind	-	
Air purifying	Deodorizing filter	X
	Plasma air purifier	X
	Pre-filter(washable / anti-fungus)	O
Installation	Drain pump	O
	E.S.P. control*	O
	Electric heater(operation)	X
	High ceiling operation*	-
Reliability	Hot start	O
	Self diagnosis	O
	Soft dry operation	X
Convenience	Auto changeover	X
	Auto cleaning	X
	Auto operation(artificial intelligence)	X
	Auto restart operation	O
	Child lock*	O
	Forced operation	X
	Group control*	O
	Sleep mode	O
	Timer(on/off)	O
	Timer(weekly)*	O
	Two thermistor control*	O
	External On/Off	O
Advanced Fan Speed Auto	O	
Others	Cold And Hot Water Valve Control (ON/OFF, AC 220 V)	O
	Cold And Hot Water Valve Control (Proportional Control, DC 0~10 V)	
	Freeze Protection Control	O

Note

- O : Applied, X : Not applied
 Accessory : Ordered and purchased separately the accessory package referring to the model name provided and install at field.
 Accessory line-ups varies by region, so check your local catalogue or local sales material.
- Some functions can be limited by remote controller.
- In case of ducted type indoor units using the wireless remote controller, it needs to connect to the wired remote controller for received the signal of that.
- * : These functions need to connect the wired remote controller.

1. List of Functions

◆ Accessory Compatibility List

Category		Product	Remark	Compatibility
				WFCA---RG0A
Wireless Remote Controller		PQWRH(C)Q0FDB	-	O
Wired Remote Controller	Simple	PQRCVCL0Q(W)	Simple	O
		PQRCHCA0Q(W)	for Hotel	O
	Standard	PREMTB001	Standard (White)	O
		PREMTBB01	Standard (Black)	O
		PREMTB100**	New Standard (White)	O
		PREMTBB10**	New Standard (Black)	O
Premium	PREMTA000(A/B)	Premium	O	
Dry contact	Simple Contact	PDRYCB000	Simple Dry Contact	O
	Communication type	PDRYCB400	Points Dry Contact (For Setback)	O
		PDRYCB300	Dry Contact For 3rd Party Thermostat	O
		PDRYCB500	Dry Contact For Modbus	O
Gateway	IDU PI485	PHNFP14A0	Connected with the Indoor Units	-
		PSNFP14A0	Connected with the Indoor Units	-
ETC	Remote temperature sensor	PQRSTA0	-	O
	Zone controller	ABZCA	-	-
	CO2 Sensor	PES-C0RV0	-	-
	Group control wire	PZCWRCG3	0.25m	O
	2-Remo Control Wire	PZCWRC2	0.25m	O
	Extension Wire	PZCWRC1	10m	O
	Wi-Fi Controller*	PWFMD200	-	O
	Independent Power Module	PRIP0	-	X
	Human Detecting Controller	PHD-TM0	-	-

Note

1. O: Possible, X: Impossible, - : Not applicable, Embedded : Included with product.
2. * : Some advanced functions controlled by individual controller cannot be operated.
3. ** : It could not be operated some functions.
4. If you need more detail, please refer to the **BECON** PDB or the manual of product. (<http://partner.lge.com> > Select Your Region : Home> Doc.Library> Product > Control(BECON))

2. Specifications

Type		Ceiling Concealed Duct - Low Static		
Model Name		Unit	WFA012RG0A	WFA018RG0A
Power Supply	Rated Power Supply	V, Φ, Hz	220-230-240, 1, 50	220-230-240, 1, 50
	Limit Range of Voltage	V	198 ~ 264	198 ~ 264
Running Current by Voltage		A	0.29-0.29-0.29	0.31-0.31-0.31
Capacity	Cooling	Condition A	1.3(1,118)	1.8(1,548)
		Condition B	1.1(946)	1.5(1,290)
		Condition C	1.2(1,032)	1.6(1,376)
		Condition D	0.7(602)	0.9(774)
	Heating	Condition A	2.0(1,721)	2.8(2,408)
		Condition B	2.1(1,806)	3.0(2,581)
Water Flow Rate	Cooling	Condition A	4.0	5.6
		Condition B	4.0	5.6
		Condition C	4.0	5.6
		Condition D	2.7	4.0
	Heating	Condition A	6.2	8.5
		Condition B	4.0	5.6
Head Loss	Cooling	Condition A	1.2	3.3
		Condition B	1.2	3.3
		Condition C	1.2	3.3
		Condition D	0.8	2.3
	Heating	Condition A	4.4	8.5
		Condition B	2.0	3.5
Power Input	H/M/L	W	8 / - / -	17 / - / -
Running Current	H/M/L	A	0.29 / - / -	0.31 / - / -
Fan	Type	-	Sirocco Fan	Sirocco Fan
	Air Flow Rate(H/M/L)	m ³ /min	5.5 / 5.0 / 4.5	8.0 / 7.0 / 6.0
	External Static Pressure (Factory Set)	mmAq	0	0
	External Static Pressure Range	mmAq	0 ~ 5	0 ~ 5
Fan Motor	Type	-	BLDC	BLDC
	Drive	-	Direct	Direct
	Output	W x No.	19 x 1	19 x 1
Dimensions	Net(W x H x D)	mm	700 x 190 x 700	700 x 190 x 700
	Shipping(W x H x D)	mm	842 x 235 x 766	842 x 235 x 766
Weight	Net	kg	16.3	16.3
	Shipping	kg	20.7	20.7
Air Filter	Type	-	Long life	Long life
Temperature Control		-	Microprocessor, Thermostat for cooling and heating	
Sound Absorbing / Thermal Insulation Material		-	Foamed polystyrene	Foamed polystyrene
Protection Device		-	Fuse	Fuse
Water Connecting Pipes	Inlet	-	BSPF G 3/4"(male)	BSPF G 3/4"(male)
	Outlet	-	BSPF G 3/4"(male)	BSPF G 3/4"(male)
Drain Pipe (Natural Drainage)	O.D / I.D	mm	-	-
Drain Pipe (using Drain Pump)	O.D / I.D	mm	Ø 32.0 / 25.0	Ø 32.0 / 25.0
Sound Pressure Level	H/M/L	dB(A)	31.0 / 30.0 / 29.0	33.0 / 32.0 / 31.0
Sound Power Level	H/M/L	dB(A)	38.0 / 36.0 / 35.0	46.0 / 43.0 / 39.0
Connecting Cable	Communication Cable (VCTF-SB)	mm ² ×cores	1.0~1.5 × 2C	1.0~1.5 × 2C

Note

- Due to our policy of innovation some specifications may be changed without notification.
- Wiring cable size must comply with the applicable local and national codes. And "Electric characteristics" chapter should be considered for electrical work and design. Especially the power cable and circuit breaker should be selected in accordance with that.
- Sound Level Values are measured at Noise Measuring chamber accordance with standard. Therefore, these values depend on the ambient conditions and values are normally higher in actual operation.
- Performances are based on the following conditions :
 - Cooling
 - Condition A : Inlet/Outlet Water Temp. 7°C / 12°C, Indoor Air Temp. 27°CDB / 19°CWB
 - Condition B : Inlet/Outlet Water Temp. 10°C / 15°C, Indoor Air Temp. 27°CDB / 19°CWB
 - Condition C : Inlet/Outlet Water Temp. 7°C / 12°C, Indoor Air Temp. 25°CDB / 17.9°CWB
 - Condition D : Inlet/Outlet Water Temp. 14°C / 18°C, Indoor Air Temp. 26°CDB / 18°CWB
 - Heating
 - Condition A : Inlet/Outlet Water Temp. 45°C / 40°C, Indoor Air Temp. 20°CDB / 15°CWB
 - Condition B : Inlet Water Temp. 50°C, Indoor Air Temp. 20°CDB / 15°CWB
- Capacity, power consumption, etc. may vary depending on the product installation conditions (temperature, conditions of use).
- Main power line should be shorter than 50m. When installing a power line longer than 50m, contact LG Electronics.

2. Specifications

Type		Ceiling Concealed Duct - Low Static		
Model Name		Unit	WFA025RG0A	WFA032RG0A
Power Supply	Rated Power Supply	V, Φ, Hz	220-230-240, 1, 50	220-230-240, 1, 50
	Limit Range of Voltage	V	198 ~ 264	198 ~ 264
Running Current by Voltage		A	0.32-0.32-0.32	0.35-0.35-0.35
Capacity	Cooling	Condition A	2.5(2,150)	3.2(2,752)
		Condition B	2.1(1,806)	2.7(2,322)
		Condition C	2.2(1,892)	2.8(2,408)
		Condition D	1.3(1,118)	1.6(1,376)
	Heating	Condition A	3.2(2,752)	3.8(3,267)
		Condition B	3.6(3,095)	4.4(3,783)
Water Flow Rate	Cooling	Condition A	7.4	9.3
		Condition B	7.4	9.3
		Condition C	7.4	9.3
		Condition D	5.0	6.3
	Heating	Condition A	9.7	11.4
		Condition B	7.4	9.3
Head Loss	Cooling	Condition A	7.6	11.8
		Condition B	7.6	11.8
		Condition C	7.6	11.8
		Condition D	5.3	8.2
	Heating	Condition A	12.5	17.8
		Condition B	6.9	11.4
Power Input	H/M/L	W	20 / - / -	27 / - / -
Running Current	H/M/L	A	0.32 / - / -	0.35 / - / -
Fan	Type	-	Sirocco Fan	Sirocco Fan
	Air Flow Rate(H/M/L)	m ³ /min	8.0 / 7.5 / 7.0	9.8 / 8.8 / 8.0
	External Static Pressure (Factory Set)	mmAq	0	0
	External Static Pressure Range	mmAq	0 ~ 5	0 ~ 5
Fan Motor	Type	-	BLDC	BLDC
	Drive	-	Direct	Direct
	Output	W x No.	19 x 1 + 5 x 1	19 x 1 + 5 x 1
Dimensions	Net(W x H x D)	mm	900 x 190 x 700	900 x 190 x 700
	Shipping(W x H x D)	mm	1,042 x 235 x 766	1,042 x 235 x 766
Weight	Net	kg	20.9	20.9
	Shipping	kg	25.8	25.8
Air Filter	Type	-	Long life	Long life
Temperature Control		-	Microprocessor, Thermostat for cooling and heating	
Sound Absorbing / Thermal Insulation Material		-	Foamed polystyrene	Foamed polystyrene
Protection Device		-	Fuse	Fuse
Water Connecting Pipes	Inlet	-	BSPF G 3/4"(male)	BSPF G 3/4"(male)
	Outlet	-	BSPF G 3/4"(male)	BSPF G 3/4"(male)
Drain Pipe (Natural Drainage)	O.D / I.D	mm	-	-
Drain Pipe (using Drain Pump)	O.D / I.D	mm	Ø 32.0 / 25.0	Ø 32.0 / 25.0
Sound Pressure Level	H/M/L	dB(A)	31.0 / 30.0 / 29.0	33.0 / 32.0 / 31.0
Sound Power Level	H/M/L	dB(A)	41.0 / 40.0 / 39.0	46.0 / 43.0 / 41.0
Connecting Cable	Communication Cable (VCTF-SB)	mm ² ×cores	1.0~1.5 × 2C	1.0~1.5 × 2C

Note

- Due to our policy of innovation some specifications may be changed without notification.
- Wiring cable size must comply with the applicable local and national codes. And "Electric characteristics" chapter should be considered for electrical work and design. Especially the power cable and circuit breaker should be selected in accordance with that.
- Sound Level Values are measured at Noise Measuring chamber accordance with standard. Therefore, these values depend on the ambient conditions and values are normally higher in actual operation.
- Performances are based on the following conditions :
 - Cooling
 - Condition A : Inlet/Outlet Water Temp. 7°C / 12°C, Indoor Air Temp. 27°CDB / 19°CWB
 - Condition B : Inlet/Outlet Water Temp. 10°C / 15°C, Indoor Air Temp. 27°CDB / 19°CWB
 - Condition C : Inlet/Outlet Water Temp. 7°C / 12°C, Indoor Air Temp. 25°CDB / 17.9°CWB
 - Condition D : Inlet/Outlet Water Temp. 14°C / 18°C, Indoor Air Temp. 26°CDB / 18°CWB
 - Heating
 - Condition A : Inlet/Outlet Water Temp. 45°C / 40°C, Indoor Air Temp. 20°CDB / 15°CWB
 - Condition B : Inlet Water Temp. 50°C, Indoor Air Temp. 20°CDB / 15°CWB
- Capacity, power consumption, etc. may vary depending on the product installation conditions (temperature, conditions of use).
- Main power line should be shorter than 50m. When installing a power line longer than 50m, contact LG Electronics.

2. Specifications

Type		Ceiling Concealed Duct - Low Static		
Model Name		Unit	WFA039RG0A	WFA055RG0A
Power Supply	Rated Power Supply	V, Φ, Hz	220-230-240, 1, 50	220-230-240, 1, 50
	Limit Range of Voltage	V	198 ~ 264	198 ~ 264
Running Current by Voltage		A	0.26-0.37-0.37	0.36-0.44-0.44
Capacity	Cooling	Condition A	3.9(3,353)	5.0(4,299)
		Condition B	3.3(2,837)	4.2(3,611)
		Condition C	3.5(3,009)	4.4(3,783)
		Condition D	2.0(1,721)	2.5(2,150)
	Heating	Condition A	4.2(3,611)	5.3(4,557)
		Condition B	5.0(4,299)	6.4(5,503)
Water Flow Rate	Cooling	Condition A	13.3	17.0
		Condition B	13.3	17.0
		Condition C	13.3	17.0
		Condition D	9.0	11.5
	Heating	Condition A	13.3	17.0
		Condition B	13.3	17.0
Head Loss	Cooling	Condition A	21.7	39.0
		Condition B	21.7	39.0
		Condition C	21.7	39.0
		Condition D	5.7	27.2
	Heating	Condition A	30.3	48.3
		Condition B	30.3	48.3
Power Input	H/M/L	W	29 / - / -	44 / - / -
Running Current	H/M/L	A	0.37 / - / -	0.44 / - / -
Fan	Type	-	Sirocco Fan	Sirocco Fan
	Air Flow Rate(H/M/L)	m ³ /min	10.7 / 9.3 / 7.2	14.4 / 10.7 / 9.3
	External Static Pressure (Factory Set)	mmAq	0	0
	External Static Pressure Range	mmAq	0 ~ 5	0 ~ 5
Fan Motor	Type	-	BLDC	BLDC
	Drive	-	Direct	Direct
	Output	W x No.	19 x 2	19 x 2
Dimensions	Net(W x H x D)	mm	1,100 x 190 x 700	1,100 x 190 x 700
	Shipping(W x H x D)	mm	1,242 x 235 x 766	1,242 x 235 x 766
Weight	Net	kg	24.2	24.2
	Shipping	kg	29.6	29.6
Air Filter	Type	-	Long life	Long life
Temperature Control		-	Microprocessor, Thermostat for cooling and heating	
Sound Absorbing / Thermal Insulation Material		-	Foamed polystyrene	Foamed polystyrene
Protection Device		-	Fuse	Fuse
Water Connecting Pipes	Inlet	-	BSPF G 3/4"(male)	BSPF G 3/4"(male)
	Outlet	-	BSPF G 3/4"(male)	BSPF G 3/4"(male)
Drain Pipe (Natural Drainage)	O.D / I.D	mm	-	-
Drain Pipe (using Drain Pump)	O.D / I.D	mm	Ø 32.0 / 25.0	Ø 32.0 / 25.0
Sound Pressure Level	H/M/L	dB(A)	28.0 / 27.0 / 26.0	31.0 / 28.0 / 26.0
Sound Power Level	H/M/L	dB(A)	43.0 / 41.0 / 40.0	47.0 / 42.0 / 41.0
Connecting Cable	Communication Cable (VCTF-SB)	mm ² ×cores	1.0~1.5 × 2C	1.0~1.5 × 2C

Note

- Due to our policy of innovation some specifications may be changed without notification.
- Wiring cable size must comply with the applicable local and national codes. And "Electric characteristics" chapter should be considered for electrical work and design. Especially the power cable and circuit breaker should be selected in accordance with that.
- Sound Level Values are measured at Noise Measuring chamber accordance with standard. Therefore, these values depend on the ambient conditions and values are normally higher in actual operation.
- Performances are based on the following conditions :
 - Cooling
 - Condition A : Inlet/Outlet Water Temp. 7°C / 12°C, Indoor Air Temp. 27°CDB / 19°CWB
 - Condition B : Inlet/Outlet Water Temp. 10°C / 15°C, Indoor Air Temp. 27°CDB / 19°CWB
 - Condition C : Inlet/Outlet Water Temp. 7°C / 12°C, Indoor Air Temp. 25°CDB / 17.9°CWB
 - Condition D : Inlet/Outlet Water Temp. 14°C / 18°C, Indoor Air Temp. 26°CDB / 18°CWB
 - Heating
 - Condition A : Inlet/Outlet Water Temp. 45°C / 40°C, Indoor Air Temp. 20°CDB / 15°CWB
 - Condition B : Inlet Water Temp. 50°C, Indoor Air Temp. 20°CDB / 15°CWB
- Capacity, power consumption, etc. may vary depending on the product installation conditions (temperature, conditions of use).
- Main power line should be shorter than 50m. When installing a power line longer than 50m, contact LG Electronics.

2. Specifications

Type		Ceiling Concealed Duct - Low Static	
Model Name		Unit	WFA066RG0A
Power Supply	Rated Power Supply	V, Φ, Hz	220-230-240, 1, 50
	Limit Range of Voltage	V	198 ~ 264
Running Current by Voltage		A	0.70-0.71-0.71
Capacity	Cooling	Condition A	6.6(5,675)
		Condition B	5.5(4,729)
		Condition C	5.9(5,073)
		Condition D	3.3(2,837)
	Heating	Condition A	6.6(5,675)
		Condition B	8.0(6,879)
Water Flow Rate	Cooling	Condition A	21.7
		Condition B	21.7
		Condition C	21.7
		Condition D	14.7
	Heating	Condition A	21.7
		Condition B	21.7
		Condition C	21.7
		Condition D	14.7
Head Loss	Cooling	Condition A	53.9
		Condition B	53.9
		Condition C	53.9
		Condition D	37.6
	Heating	Condition A	71.7
		Condition B	71.7
Power Input	H/M/L	W	81 / - / -
Running Current	H/M/L	A	0.71 / - / -
Fan	Type	-	Sirocco Fan
	Air Flow Rate(H/M/L)	m ³ /min	20.1 / 17.3 / 14.4
	External Static Pressure (Factory Set)	mmAq	0
	External Static Pressure Range	mmAq	0 ~ 5
Fan Motor	Type	-	BLDC
	Drive	-	Direct
	Output	W x No.	19 x 2
Dimensions	Net(W x H x D)	mm	1,100 x 190 x 700
	Shipping(W x H x D)	mm	1,242 x 235 x 766
Weight	Net	kg	24.2
	Shipping	kg	29.6
Air Filter	Type	-	Long life
Temperature Control		-	Microprocessor, Thermostat for cooling and heating
Sound Absorbing / Thermal Insulation Material		-	Foamed polystyrene
Protection Device		-	Fuse
Water Connecting Pipes	Inlet	-	BSPF G 3/4"(male)
	Outlet	-	BSPF G 3/4"(male)
Drain Pipe (Natural Drainage)	O.D / I.D	mm	-
Drain Pipe (using Drain Pump)	O.D / I.D	mm	Ø 32.0 / 25.0
Sound Pressure Level	H/M/L	dB(A)	38.0 / 34.0 / 31.0
Sound Power Level	H/M/L	dB(A)	55.0 / 52.0 / 48.0
Connecting Cable	Communication Cable (VCTF-SB)	mm ² ×cores	1.0~1.5 × 2C

Note

- Due to our policy of innovation some specifications may be changed without notification.
- Wiring cable size must comply with the applicable local and national codes. And "Electric characteristics" chapter should be considered for electrical work and design. Especially the power cable and circuit breaker should be selected in accordance with that.
- Sound Level Values are measured at Noise Measuring chamber accordance with standard. Therefore, these values depend on the ambient conditions and values are normally higher in actual operation.
- Performances are based on the following conditions :
 - Cooling
 - Condition A : Inlet/Outlet Water Temp. 7°C / 12°C, Indoor Air Temp. 27°CDB / 19°CWB
 - Condition B : Inlet/Outlet Water Temp. 10°C / 15°C, Indoor Air Temp. 27°CDB / 19°CWB
 - Condition C : Inlet/Outlet Water Temp. 7°C / 12°C, Indoor Air Temp. 25°CDB / 17.9°CWB
 - Condition D : Inlet/Outlet Water Temp. 14°C / 18°C, Indoor Air Temp. 26°CDB / 18°CWB
 - Heating
 - Condition A : Inlet/Outlet Water Temp. 45°C / 40°C, Indoor Air Temp. 20°CDB / 15°CWB
 - Condition B : Inlet Water Temp. 50°C, Indoor Air Temp. 20°CDB / 15°CWB
- Capacity, power consumption, etc. may vary depending on the product installation conditions (temperature, conditions of use).
- Main power line should be shorter than 50m. When installing a power line longer than 50m, contact LG Electronics.

3. Dimensions

3.1 Dimensional Drawings

■ WFC A012RG0A, WFC A018RG0A

◆ L1 Chassis

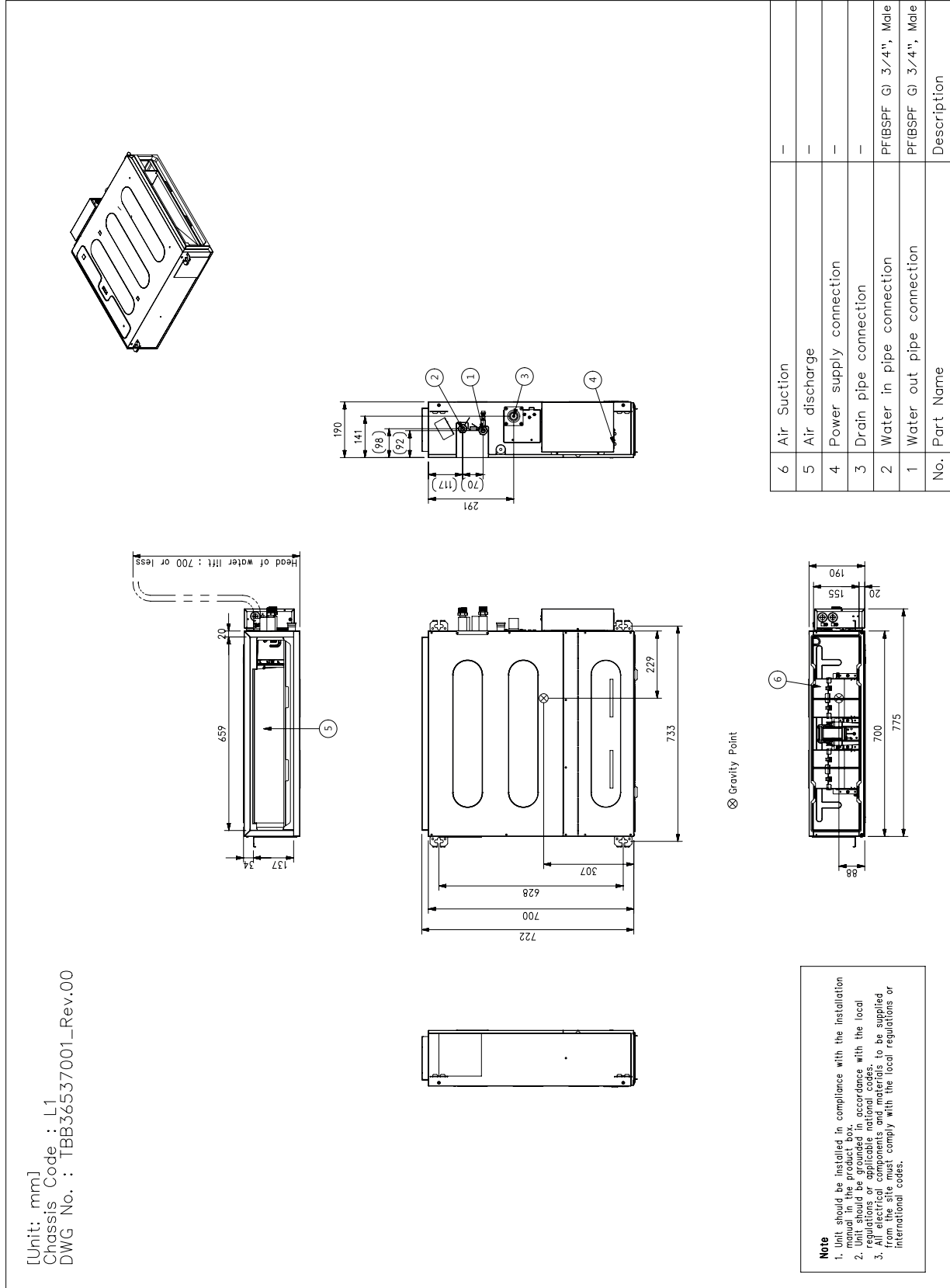

[Unit: mm]
 Chassis Code : L1
 DWG No. : TBB36537001_Rev.00

No.	Part Name	Description
6	Air Suction	-
5	Air discharge	-
4	Power supply connection	-
3	Drain pipe connection	-
2	Water in pipe connection	PF(BSPF G) 3/4", Male
1	Water out pipe connection	PF(BSPF G) 3/4", Male

Note
 1. Unit should be installed in compliance with the installation manual in the product box.
 2. Unit should be grounded in accordance with the local electrical codes.
 3. All electrical components and materials to be supplied from the site must comply with the local regulations or international codes.

3. Dimensions

■ WFC A025RG0A, WFC A032RG0A

◆ L2 Chassis

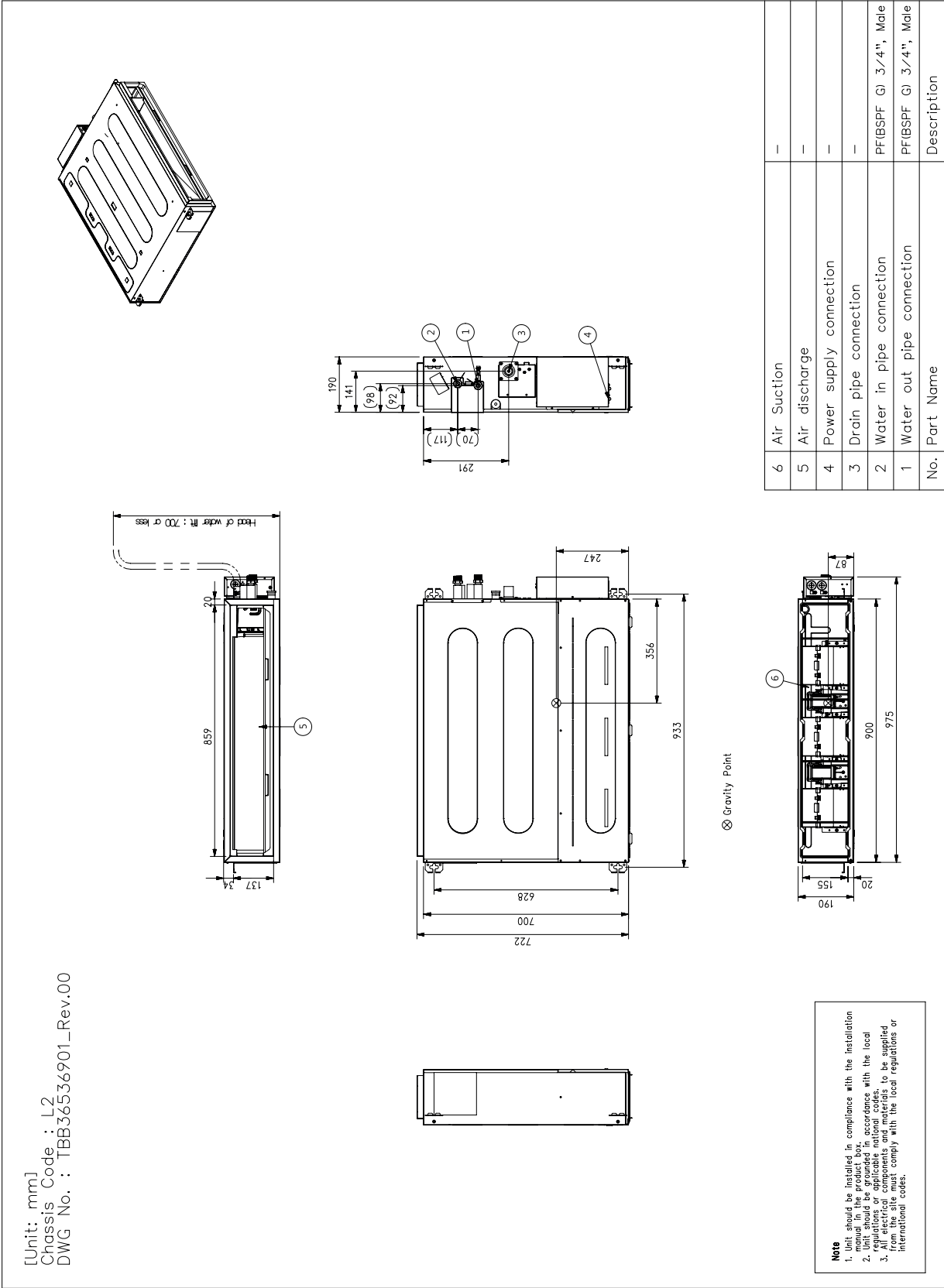

3. Dimensions

■ WFC A039RG0A, WFC A055RG0A, WFC A066RG0A

◆ L3 Chassis

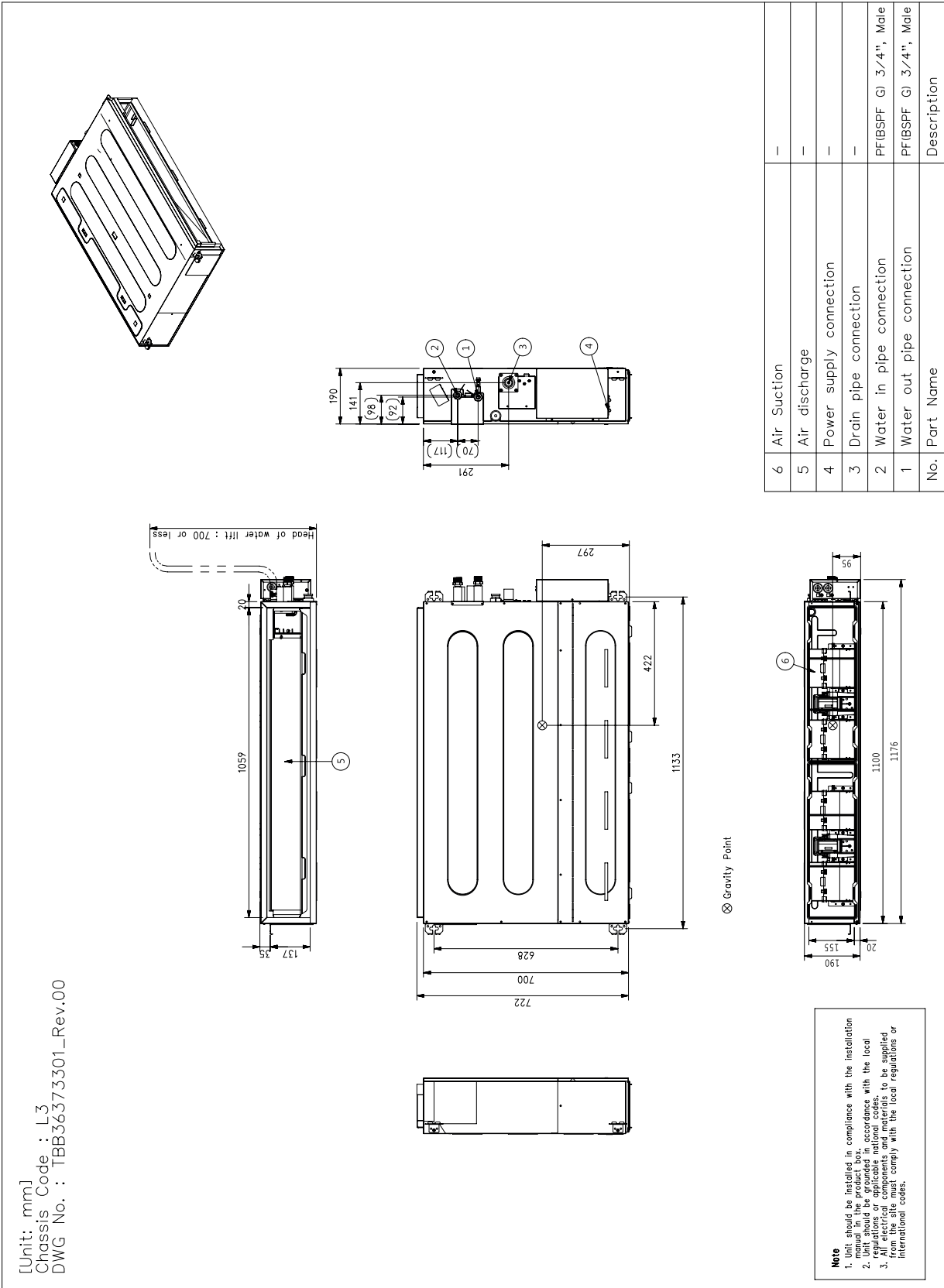

3. Dimensions

3.2 Installation Space

Top view
[Unit: mm(inch)]

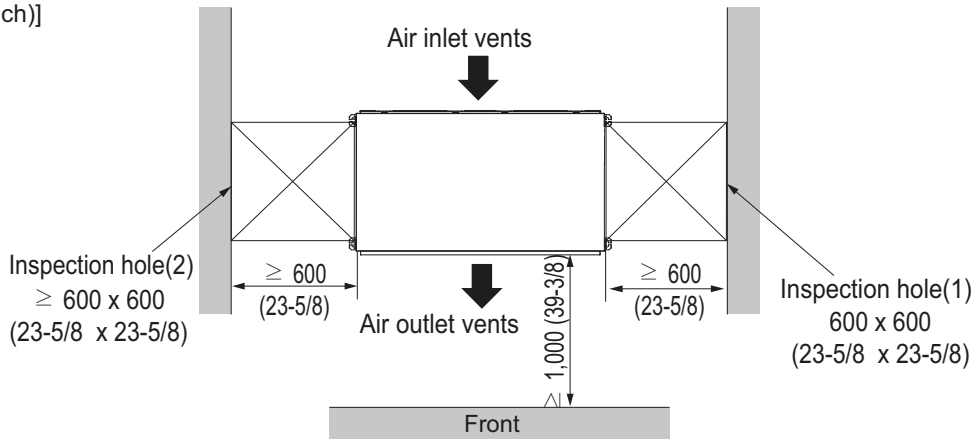

* If distance between false ceiling and actual ceiling is more than 100cm (39-3/8 inch), the number of inspection hole could be decreased to 1. But if that is less than 20cm (7-7/8 inch), the hole size should be more than size of Indoor Unit.

Front view
[Unit: mm(inch)]

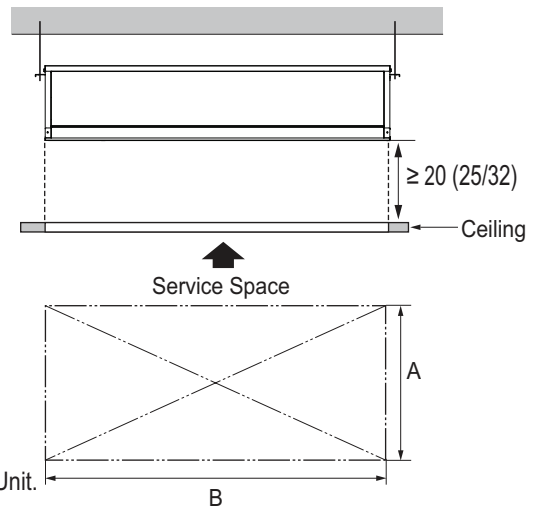
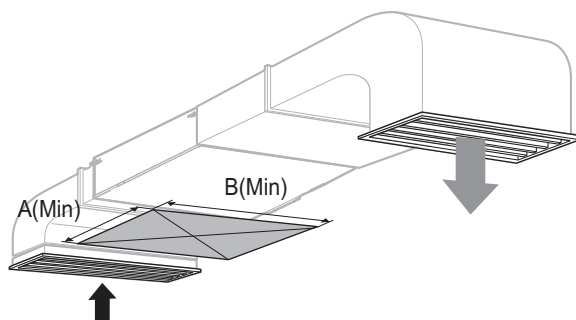

* If distance between false ceiling and actual ceiling is less than 20cm (7-7/8 inch), the hole size should be more than size of Indoor Unit.

* These figures are representative. Actual appearance of indoor unit may be different but clearances will stay the same.

Note

- Places where products are installed should not be any obstacles to the air circulation or installation. Ensure the spaces from the wall, ceiling, or other obstacles.
- According to type of indoor unit, external appearance or installed structure could be different.
- According to product type, model line up, sales region..etc, applicability of each chassis could be different.
- Install certainly the decoration panel. Cool air leakage causes sweating or falling of water-drops.

4. Piping Diagrams

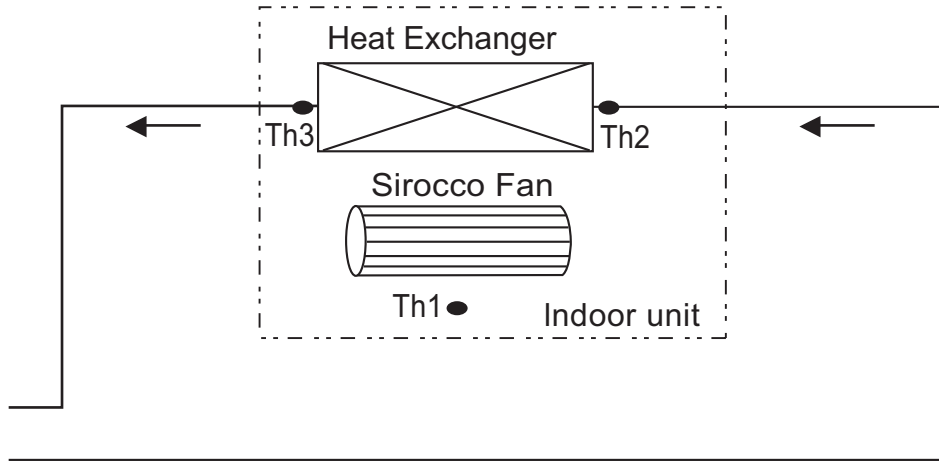

LOC.	Description
Th1	Thermistor for room air temperature
Th2	Thermistor for pipe in temperature
Th3	Thermistor for pipe out temperature

5. Wiring Diagrams

■ L1 Chassis

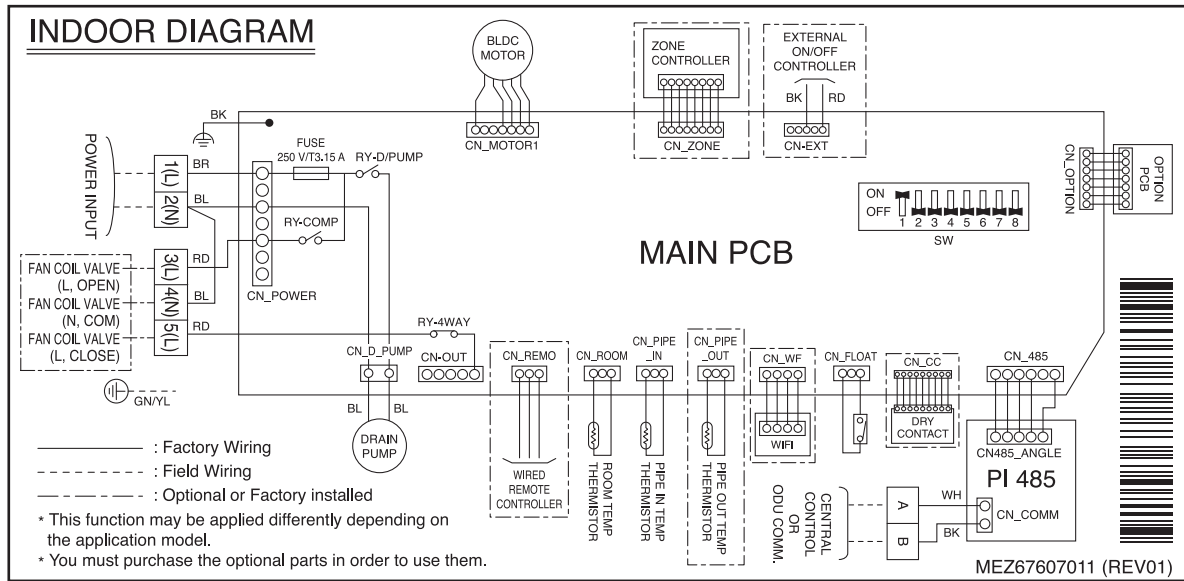

◆ Dip SW Setting Table

No.	Function	Description	Setting		Default (At the time of factory ship-out)	FCU
			OFF	ON		
SW1	Communication mode	Communication / Non communication model selection	Communication	Non communication	ON	Use
SW2	Cooling / heating mode	Cooling / heating mode selection	Cooling/heating	Cooling exclusive	OFF	Use
SW3	Group control	Master / slave selection	Master	Slave	OFF	Use
SW4	Dry contact mode	- Variable : Manual or automatic selection of wired wireless remote control - Automatic	Variable	Automatic	OFF	Use
SW5	Fan continuous operation	For Duct type	Fan continuous operation removal	Fan continuous operation	OFF	N/A
	EXTRA	Cassette type	-	-	OFF	
	Installation type	For Ceiling Suspended type	Ceiling	Floor	OFF	
		For Round Cassette	Exposed	Half Concealed	OFF	
SW6	Heater linkage	-	-	-	OFF	N/A
SW7	Ventilator linkage	Selection of Ventilator linkage	Linkage Removal	Working	OFF	N/A
	Vane selection (Console)	For Console type (Top/Bottom vane)	Top + Bottom Vane	Top Vane Only		
	Region selection	Selection tropical region	General model	Tropical model		
SW8	Communication method	LGAP/Modbus selection	Modbus	LGAP	OFF	Use

Note

- For product type, available Dip Switch No. could be different.
- Dip switch marked 'N/A' should be OFF. Those will be used for other product.

5. Wiring Diagrams

■ L2 / L3 Chassis

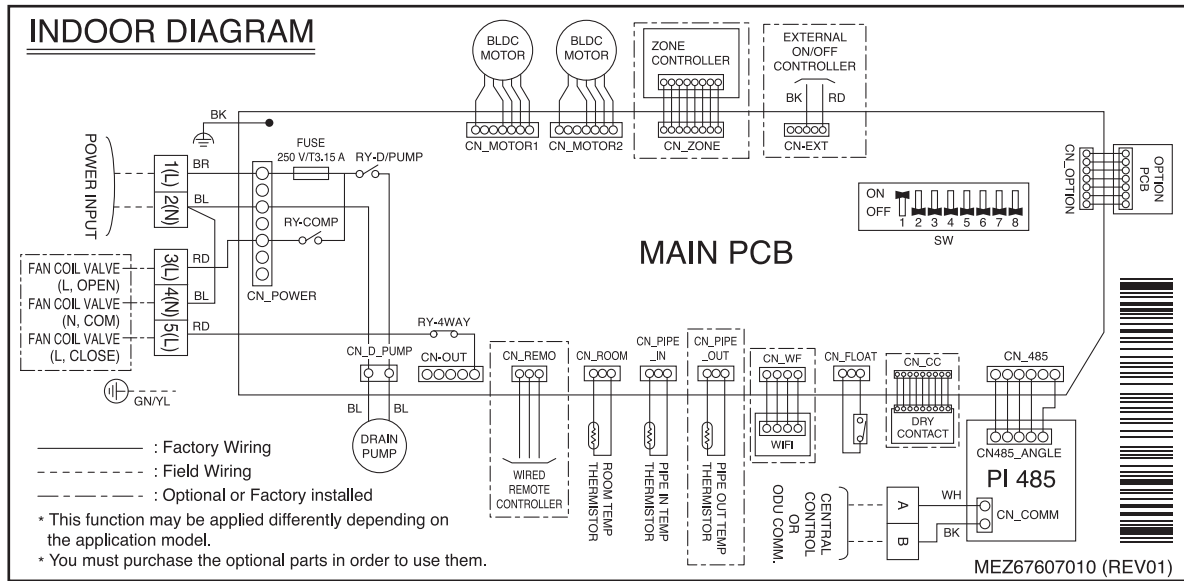

◆ Dip SW Setting Table

No.	Function	Description	Setting		Default (At the time of factory ship-out)	FCU
			OFF	ON		
SW1	Communication mode	Communication / Non communication model selection	Communication	Non communication	ON	Use
SW2	Cooling / heating mode	Cooling / heating mode selection	Cooling/heating	Cooling exclusive	OFF	Use
SW3	Group control	Master / slave selection	Master	Slave	OFF	Use
SW4	Dry contact mode	- Variable : Manual or automatic selection of wired wireless remote control - Automatic	Variable	Automatic	OFF	Use
SW5	Fan continuous operation	For Duct type	Fan continuous operation removal	Fan continuous operation	OFF	N/A
	EXTRA	Cassette type	-	-	OFF	
	Installation type	For Ceiling Suspended type For Round Cassette	Ceiling Exposed	Floor Half Concealed	OFF	
SW6	Heater linkage	-	-	-	OFF	N/A
SW7	Ventilator linkage	Selection of Ventilator linkage	Linkage Removal	Working	OFF	N/A
	Vane selection (Console)	For Console type (Top/Bottom vane)	Top + Bottom Vane	Top Vane Only		
	Region selection	Selection tropical region	General model	Tropical model		
SW8	Communication method	LGAP/Modbus selection	Modbus	LGAP	OFF	Use

Note

- For product type, available Dip Switch No. could be different.
- Dip switch marked 'N/A' should be OFF. Those will be used for other product.

6. Capacity Tables

Inlet Water Temp. (°C)	Water Temp Difference (°C)	Air Temp (°C DB)	Air Temp(17°C WB)				Air Temp(19°C WB)				Air Temp(21°C WB)				Air Temp(23°C WB)			
			TC (kW)	SHC (kW)	Water Flow Rate (LPM)	Pressure Drop (kPa)	TC (kW)	SHC (kW)	Water Flow Rate (LPM)	Pressure Drop (kPa)	TC (kW)	SHC (kW)	Water Flow Rate (LPM)	Pressure Drop (kPa)	TC (kW)	SHC (kW)	Water Flow Rate (LPM)	Pressure Drop (kPa)
9	4	24	0.81	0.81	2.9	0.8	1.11	0.84	4.0	1.3	1.45	0.74	5.2	2.1	1.83	0.64	6.6	3.1
		25	0.81	0.81	2.9	0.8	1.11	0.94	4.0	1.3	1.44	0.84	5.2	2.1	1.82	0.74	6.5	3.1
		26	0.80	0.80	2.9	0.8	1.10	1.03	4.0	1.3	1.44	0.93	5.2	2.1	1.82	0.83	6.5	3.1
		27	0.80	0.80	2.9	0.8	1.10	1.10	3.9	1.3	1.44	1.02	5.2	2.1	1.81	0.92	6.5	3.1
		28	0.80	0.80	2.9	0.8	1.10	1.10	3.9	1.3	1.43	1.11	5.1	2.1	1.81	1.01	6.5	3.1
		29	0.80	0.80	2.9	0.8	1.09	1.09	3.9	1.3	1.43	1.21	5.1	2.1	1.81	1.11	6.5	3.1
	5	30	0.79	0.79	2.8	0.8	1.09	1.09	3.9	1.3	1.43	1.30	5.1	2.1	1.80	1.20	6.5	3.1
		24	0.79	0.79	2.3	0.4	1.09	0.84	3.1	0.9	1.42	0.74	4.1	1.4	1.80	0.64	5.2	2.1
		25	0.79	0.79	2.3	0.4	1.08	0.93	3.1	0.9	1.42	0.83	4.1	1.4	1.80	0.73	5.2	2.1
		26	0.78	0.78	2.2	0.4	1.08	1.02	3.1	0.9	1.42	0.92	4.1	1.4	1.79	0.82	5.2	2.1
		27	0.78	0.78	2.2	0.4	1.08	1.08	3.1	0.9	1.41	1.01	4.1	1.4	1.79	0.91	5.1	2.1
		28	0.78	0.78	2.2	0.4	1.07	1.07	3.1	0.9	1.41	1.11	4.0	1.4	1.79	1.01	5.1	2.1
	6	29	0.77	0.77	2.2	0.4	1.07	1.07	3.1	0.9	1.41	1.20	4.0	1.4	1.78	1.10	5.1	2.1
		30	0.77	0.77	2.2	0.4	1.07	1.07	3.1	0.9	1.40	1.29	4.0	1.4	1.78	1.19	5.1	2.0
		24	0.77	0.77	1.8	0.2	1.06	0.83	2.5	0.6	1.40	0.73	3.3	1.0	1.78	0.63	4.3	1.5
		25	0.76	0.76	1.8	0.2	1.06	0.92	2.5	0.6	1.40	0.82	3.3	1.0	1.77	0.72	4.2	1.5
		26	0.76	0.76	1.8	0.2	1.06	1.01	2.5	0.6	1.39	0.91	3.3	1.0	1.77	0.81	4.2	1.5
		27	0.76	0.76	1.8	0.2	1.06	1.06	2.5	0.6	1.39	1.01	3.3	1.0	1.77	0.91	4.2	1.5
	7	28	0.76	0.76	1.8	0.2	1.05	1.05	2.5	0.6	1.39	1.10	3.3	1.0	1.76	1.00	4.2	1.5
		29	0.75	0.75	1.8	0.2	1.05	1.05	2.5	0.6	1.38	1.19	3.3	1.0	1.76	1.09	4.2	1.5
		30	0.75	0.75	1.8	0.2	1.05	1.05	2.5	0.6	1.38	1.28	3.3	1.0	1.75	1.18	4.2	1.5
		24	0.74	0.74	1.5	0.2	1.04	0.82	2.1	0.3	1.38	0.72	2.8	0.7	1.75	0.62	3.6	1.1
		25	0.74	0.74	1.5	0.2	1.04	0.91	2.1	0.3	1.37	0.81	2.8	0.7	1.75	0.71	3.6	1.1
		26	0.74	0.74	1.5	0.2	1.04	1.00	2.1	0.3	1.37	0.90	2.8	0.7	1.74	0.80	3.6	1.1
	8	27	0.74	0.74	1.5	0.2	1.03	1.03	2.1	0.3	1.37	1.00	2.8	0.7	1.74	0.90	3.6	1.1
		28	0.73	0.73	1.5	0.2	1.03	1.03	2.1	0.3	1.36	1.09	2.8	0.7	1.74	0.99	3.6	1.1
		29	0.73	0.73	1.5	0.2	1.03	1.03	2.1	0.3	1.36	1.18	2.8	0.7	1.73	1.08	3.6	1.1
		30	0.73	0.73	1.5	0.2	1.02	1.02	2.1	0.3	1.36	1.27	2.8	0.7	1.73	1.18	3.6	1.1
		24	0.72	0.72	1.3	0.2	1.02	0.81	1.8	0.2	1.35	0.71	2.4	0.5	1.73	0.61	3.1	0.9
		25	0.72	0.72	1.3	0.2	1.02	0.90	1.8	0.2	1.35	0.80	2.4	0.5	1.72	0.70	3.1	0.9
9	26	0.72	0.72	1.3	0.2	1.01	1.00	1.8	0.2	1.35	0.90	2.4	0.5	1.72	0.80	3.1	0.9	
	27	0.71	0.71	1.3	0.2	1.01	1.01	1.8	0.2	1.34	0.99	2.4	0.5	1.72	0.89	3.1	0.9	
	28	0.71	0.71	1.3	0.2	1.01	1.01	1.8	0.2	1.34	1.08	2.4	0.5	1.71	0.98	3.1	0.9	
	29	0.71	0.71	1.3	0.2	1.00	1.00	1.8	0.2	1.34	1.17	2.4	0.5	1.71	1.07	3.1	0.9	
	30	0.71	0.71	1.3	0.2	1.00	1.00	1.8	0.2	1.33	1.27	2.4	0.5	1.70	1.17	3.1	0.9	

Note

- TC : Total capacity(W), SHC : Sensible Heat Capacity(W)
- Performances are based on the following conditions :
 - Cooling
 - Condition A : Inlet/Outlet Water Temp. 7°C / 12°C, Indoor Air Temp. 27°CDB / 19°CWB
 - Condition B : Inlet/Outlet Water Temp. 10°C / 15°C, Indoor Air Temp. 27°CDB / 19°CWB
 - Condition C : Inlet/Outlet Water Temp. 7°C / 12°C, Indoor Air Temp. 25°CDB / 17.9°CWB
 - Condition D : Inlet/Outlet Water Temp. 14°C / 18°C, Indoor Air Temp. 26°CDB / 18°CWB
- Above capacity tables shows representative values according to the change in temperature or water flow rate, etc., it may vary depending on the installation conditions and the surrounding environment.

6. Capacity Tables

Inlet Water Temp. (°C)	Water Temp Difference (°C)	Air Temp (°C DB)	Air Temp(17°C WB)				Air Temp(19°C WB)				Air Temp(21°C WB)				Air Temp(23°C WB)			
			TC (kW)	SHC (kW)	Water Flow Rate (LPM)	Pressure Drop (kPa)	TC (kW)	SHC (kW)	Water Flow Rate (LPM)	Pressure Drop (kPa)	TC (kW)	SHC (kW)	Water Flow Rate (LPM)	Pressure Drop (kPa)	TC (kW)	SHC (kW)	Water Flow Rate (LPM)	Pressure Drop (kPa)
9	4	24	1.12	1.12	4.0	2.2	1.54	1.18	5.5	3.7	2.00	1.04	7.2	5.8	2.53	0.89	9.1	8.7
		25	1.12	1.12	4.0	2.1	1.53	1.31	5.5	3.7	2.00	1.17	7.2	5.8	2.52	1.02	9.1	8.7
		26	1.11	1.11	4.0	2.1	1.53	1.44	5.5	3.6	1.99	1.30	7.2	5.8	2.52	1.15	9.0	8.6
		27	1.11	1.11	4.0	2.1	1.52	1.52	5.5	3.6	1.99	1.43	7.1	5.7	2.51	1.29	9.0	8.6
		28	1.10	1.10	4.0	2.1	1.52	1.52	5.5	3.6	1.98	1.56	7.1	5.7	2.51	1.42	9.0	8.6
		29	1.10	1.10	4.0	2.1	1.51	1.51	5.4	3.6	1.98	1.69	7.1	5.7	2.50	1.55	9.0	8.5
	30	1.10	1.10	3.9	2.1	1.51	1.51	5.4	3.6	1.98	1.82	7.1	5.7	2.50	1.68	9.0	8.5	
	5	24	1.09	1.09	3.1	1.4	1.50	1.17	4.3	2.4	1.97	1.03	5.7	3.9	2.50	0.88	7.2	5.8
		25	1.09	1.09	3.1	1.4	1.50	1.30	4.3	2.4	1.97	1.16	5.6	3.8	2.49	1.01	7.2	5.8
		26	1.08	1.08	3.1	1.4	1.50	1.43	4.3	2.4	1.96	1.29	5.6	3.8	2.48	1.14	7.1	5.7
		27	1.08	1.08	3.1	1.4	1.49	1.49	4.3	2.4	1.96	1.42	5.6	3.8	2.48	1.27	7.1	5.7
		28	1.07	1.07	3.1	1.4	1.49	1.49	4.3	2.4	1.95	1.55	5.6	3.8	2.47	1.41	7.1	5.7
		29	1.07	1.07	3.1	1.4	1.48	1.48	4.3	2.4	1.95	1.68	5.6	3.8	2.47	1.54	7.1	5.7
	30	1.07	1.07	3.1	1.4	1.48	1.48	4.2	2.4	1.94	1.81	5.6	3.8	2.46	1.67	7.1	5.7	
	6	24	1.06	1.06	2.5	0.9	1.47	1.16	3.5	1.7	1.94	1.01	4.6	2.7	2.46	0.87	5.9	4.1
		25	1.06	1.06	2.5	0.9	1.47	1.29	3.5	1.7	1.93	1.15	4.6	2.7	2.46	1.00	5.9	4.1
		26	1.05	1.05	2.5	0.9	1.46	1.42	3.5	1.7	1.93	1.28	4.6	2.7	2.45	1.13	5.9	4.1
		27	1.05	1.05	2.5	0.9	1.46	1.46	3.5	1.7	1.92	1.41	4.6	2.7	2.45	1.26	5.9	4.1
		28	1.04	1.04	2.5	0.9	1.46	1.46	3.5	1.7	1.92	1.54	4.6	2.7	2.44	1.39	5.8	4.1
		29	1.04	1.04	2.5	0.9	1.45	1.45	3.5	1.7	1.91	1.67	4.6	2.7	2.44	1.52	5.8	4.1
	30	1.04	1.04	2.5	0.9	1.45	1.45	3.5	1.7	1.91	1.80	4.6	2.7	2.43	1.66	5.8	4.0	
	7	24	1.03	1.03	2.1	0.5	1.44	1.15	3.0	1.3	1.90	1.00	3.9	2.1	2.43	0.86	5.0	3.1
		25	1.03	1.03	2.1	0.5	1.44	1.28	2.9	1.3	1.90	1.13	3.9	2.0	2.42	0.99	5.0	3.1
		26	1.02	1.02	2.1	0.5	1.43	1.41	2.9	1.3	1.90	1.26	3.9	2.0	2.42	1.12	5.0	3.1
		27	1.02	1.02	2.1	0.5	1.43	1.43	2.9	1.3	1.89	1.40	3.9	2.0	2.41	1.25	4.9	3.1
		28	1.01	1.01	2.1	0.5	1.42	1.42	2.9	1.2	1.89	1.53	3.9	2.0	2.41	1.38	4.9	3.1
		29	1.01	1.01	2.1	0.5	1.42	1.42	2.9	1.2	1.88	1.66	3.9	2.0	2.40	1.51	4.9	3.0
	30	1.01	1.01	2.1	0.4	1.42	1.42	2.9	1.2	1.88	1.79	3.8	2.0	2.40	1.64	4.9	3.0	
	8	24	1.00	1.00	1.8	0.3	1.41	1.14	2.5	0.9	1.87	0.99	3.4	1.6	2.39	0.85	4.3	2.4
		25	1.00	1.00	1.8	0.3	1.41	1.27	2.5	0.9	1.87	1.12	3.4	1.6	2.39	0.98	4.3	2.4
26		0.99	0.99	1.8	0.3	1.40	1.40	2.5	0.9	1.86	1.25	3.3	1.6	2.38	1.11	4.3	2.4	
27		0.99	0.99	1.8	0.3	1.40	1.40	2.5	0.9	1.86	1.38	3.3	1.6	2.38	1.24	4.3	2.4	
28		0.98	0.98	1.8	0.3	1.39	1.39	2.5	0.9	1.85	1.52	3.3	1.6	2.37	1.37	4.3	2.4	
29		0.98	0.98	1.8	0.3	1.39	1.39	2.5	0.9	1.85	1.65	3.3	1.6	2.37	1.50	4.3	2.4	
30	0.98	0.98	1.8	0.3	1.38	1.38	2.5	0.9	1.84	1.78	3.3	1.5	2.36	1.63	4.2	2.4		

Note

- TC : Total capacity(W), SHC : Sensible Heat Capacity(W)
- Performances are based on the following conditions :
 - Cooling
 - Condition A : Inlet/Outlet Water Temp. 7°C / 12°C, Indoor Air Temp. 27°CDB / 19°CWB
 - Condition B : Inlet/Outlet Water Temp. 10°C / 15°C, Indoor Air Temp. 27°CDB / 19°CWB
 - Condition C : Inlet/Outlet Water Temp. 7°C / 12°C, Indoor Air Temp. 25°CDB / 17.9°CWB
 - Condition D : Inlet/Outlet Water Temp. 14°C / 18°C, Indoor Air Temp. 26°CDB / 18°CWB
- Above capacity tables shows representative values according to the change in temperature or water flow rate, etc., it may vary depending on the installation conditions and the surrounding environment.

6. Capacity Tables

Inlet Water Temp. (°C)	Water Temp Difference (°C)	Air Temp (°C DB)	Air Temp(17°C WB)				Air Temp(19°C WB)				Air Temp(21°C WB)				Air Temp(23°C WB)			
			TC (kW)	SHC (kW)	Water Flow Rate (LPM)	Pressure Drop (kPa)	TC (kW)	SHC (kW)	Water Flow Rate (LPM)	Pressure Drop (kPa)	TC (kW)	SHC (kW)	Water Flow Rate (LPM)	Pressure Drop (kPa)	TC (kW)	SHC (kW)	Water Flow Rate (LPM)	Pressure Drop (kPa)
9	4	24	1.57	1.57	5.6	5.0	2.14	1.49	7.7	8.5	2.77	1.36	10.0	13.4	3.48	1.22	12.5	19.9
		25	1.56	1.56	5.6	5.0	2.13	1.64	7.7	8.5	2.77	1.50	9.9	13.3	3.48	1.37	12.5	19.8
		26	1.56	1.56	5.6	5.0	2.13	1.78	7.6	8.5	2.76	1.65	9.9	13.3	3.47	1.52	12.5	19.7
		27	1.56	1.56	5.6	4.9	2.12	1.93	7.6	8.4	2.76	1.80	9.9	13.2	3.47	1.67	12.4	19.7
		28	1.55	1.55	5.6	4.9	2.12	2.08	7.6	8.4	2.75	1.95	9.9	13.2	3.46	1.82	12.4	19.6
		29	1.55	1.55	5.6	4.9	2.11	2.11	7.6	8.4	2.75	2.10	9.9	13.1	3.45	1.97	12.4	19.6
	30	1.54	1.54	5.5	4.9	2.11	2.11	7.6	8.3	2.74	2.24	9.8	13.1	3.45	2.11	12.4	19.5	
	5	24	1.53	1.53	4.4	3.3	2.10	1.47	6.0	5.6	2.73	1.34	7.8	8.8	3.44	1.21	9.9	13.2
		25	1.52	1.52	4.4	3.3	2.09	1.62	6.0	5.6	2.72	1.49	7.8	8.8	3.43	1.36	9.9	13.1
		26	1.52	1.52	4.4	3.2	2.09	1.77	6.0	5.6	2.72	1.64	7.8	8.8	3.43	1.51	9.8	13.1
		27	1.51	1.51	4.3	3.2	2.08	1.92	6.0	5.5	2.71	1.78	7.8	8.8	3.42	1.65	9.8	13.1
		28	1.51	1.51	4.3	3.2	2.08	2.08	6.0	5.5	2.71	1.93	7.8	8.7	3.41	1.80	9.8	13.0
		29	1.51	1.51	4.3	3.2	2.07	2.07	5.9	5.5	2.70	2.08	7.8	8.7	3.41	1.95	9.8	13.0
	30	1.50	1.50	4.3	3.2	2.07	2.07	5.9	5.5	2.70	2.23	7.7	8.7	3.40	2.10	9.8	12.9	
	6	24	1.49	1.49	3.6	2.3	2.05	1.46	4.9	4.0	2.69	1.32	6.4	6.3	3.39	1.19	8.1	9.4
		25	1.48	1.48	3.5	2.3	2.05	1.60	4.9	4.0	2.68	1.47	6.4	6.3	3.39	1.34	8.1	9.4
		26	1.48	1.48	3.5	2.3	2.04	1.75	4.9	3.9	2.67	1.62	6.4	6.2	3.38	1.49	8.1	9.3
		27	1.47	1.47	3.5	2.3	2.04	1.90	4.9	3.9	2.67	1.77	6.4	6.2	3.37	1.64	8.1	9.3
		28	1.47	1.47	3.5	2.3	2.03	2.03	4.9	3.9	2.66	1.92	6.4	6.2	3.37	1.79	8.1	9.3
		29	1.47	1.47	3.5	2.2	2.03	2.03	4.9	3.9	2.66	2.06	6.4	6.2	3.36	1.93	8.0	9.3
	30	1.46	1.46	3.5	2.2	2.02	2.02	4.8	3.9	2.65	2.21	6.3	6.2	3.36	2.08	8.0	9.2	
	7	24	1.44	1.44	3.0	1.7	2.01	1.44	4.1	2.9	2.64	1.31	5.4	4.7	3.35	1.18	6.9	7.0
		25	1.44	1.44	3.0	1.7	2.00	1.59	4.1	2.9	2.64	1.46	5.4	4.7	3.34	1.32	6.9	7.0
		26	1.44	1.44	2.9	1.7	2.00	1.74	4.1	2.9	2.63	1.60	5.4	4.7	3.33	1.47	6.8	7.0
		27	1.43	1.43	2.9	1.7	2.00	1.88	4.1	2.9	2.62	1.75	5.4	4.6	3.33	1.62	6.8	7.0
		28	1.43	1.43	2.9	1.6	1.99	1.99	4.1	2.9	2.62	1.90	5.4	4.6	3.32	1.77	6.8	7.0
		29	1.42	1.42	2.9	1.6	1.99	1.99	4.1	2.9	2.61	2.05	5.4	4.6	3.32	1.92	6.8	6.9
	30	1.42	1.42	2.9	1.6	1.98	1.98	4.1	2.9	2.61	2.20	5.3	4.6	3.31	2.07	6.8	6.9	
	8	24	1.40	1.40	2.5	1.2	1.97	1.42	3.5	2.3	2.60	1.29	4.7	3.6	3.30	1.16	5.9	5.5
		25	1.40	1.40	2.5	1.2	1.96	1.57	3.5	2.3	2.59	1.44	4.6	3.6	3.29	1.31	5.9	5.5
26		1.39	1.39	2.5	1.1	1.96	1.72	3.5	2.2	2.59	1.59	4.6	3.6	3.29	1.46	5.9	5.4	
27		1.39	1.39	2.5	1.1	1.95	1.87	3.5	2.2	2.58	1.74	4.6	3.6	3.28	1.61	5.9	5.4	
28		1.39	1.39	2.5	1.1	1.95	1.95	3.5	2.2	2.57	1.88	4.6	3.6	3.28	1.75	5.9	5.4	
29		1.38	1.38	2.5	1.1	1.94	1.94	3.5	2.2	2.57	2.03	4.6	3.6	3.27	1.90	5.9	5.4	
30	1.38	1.38	2.5	1.1	1.94	1.94	3.5	2.2	2.56	2.18	4.6	3.6	3.26	2.05	5.9	5.4		

Note

- TC : Total capacity(W), SHC : Sensible Heat Capacity(W)
- Performances are based on the following conditions :
 - Cooling
 - Condition A : Inlet/Outlet Water Temp. 7°C / 12°C, Indoor Air Temp. 27°CDB / 19°CWB
 - Condition B : Inlet/Outlet Water Temp. 10°C / 15°C, Indoor Air Temp. 27°CDB / 19°CWB
 - Condition C : Inlet/Outlet Water Temp. 7°C / 12°C, Indoor Air Temp. 25°CDB / 17.9°CWB
 - Condition D : Inlet/Outlet Water Temp. 14°C / 18°C, Indoor Air Temp. 26°CDB / 18°CWB
- Above capacity tables shows representative values according to the change in temperature or water flow rate, etc., it may vary depending on the installation conditions and the surrounding environment.

6. Capacity Tables

Inlet Water Temp. (°C)	Water Temp Difference (°C)	Air Temp (°C DB)	Air Temp(17°C WB)				Air Temp(19°C WB)				Air Temp(21°C WB)				Air Temp(23°C WB)			
			TC (kW)	SHC (kW)	Water Flow Rate (LPM)	Pressure Drop (kPa)	TC (kW)	SHC (kW)	Water Flow Rate (LPM)	Pressure Drop (kPa)	TC (kW)	SHC (kW)	Water Flow Rate (LPM)	Pressure Drop (kPa)	TC (kW)	SHC (kW)	Water Flow Rate (LPM)	Pressure Drop (kPa)
9	4	24	2.01	2.01	7.2	7.8	2.74	1.87	9.8	13.3	3.55	1.72	12.7	20.8	4.45	1.57	16.0	30.9
		25	2.01	2.01	7.2	7.8	2.73	2.05	9.8	13.2	3.54	1.90	12.7	20.7	4.44	1.75	15.9	30.8
		26	2.00	2.00	7.2	7.7	2.73	2.23	9.8	13.2	3.53	2.08	12.7	20.7	4.44	1.93	15.9	30.7
		27	2.00	2.00	7.2	7.7	2.72	2.41	9.8	13.1	3.53	2.26	12.7	20.6	4.43	2.11	15.9	30.6
		28	1.99	1.99	7.1	7.7	2.72	2.59	9.7	13.1	3.52	2.44	12.6	20.5	4.42	2.29	15.9	30.5
		29	1.99	1.99	7.1	7.6	2.71	2.71	9.7	13.0	3.52	2.62	12.6	20.5	4.41	2.47	15.8	30.4
	30	1.98	1.98	7.1	7.6	2.70	2.70	9.7	13.0	3.51	2.80	12.6	20.4	4.41	2.65	15.8	30.4	
	5	24	1.96	1.96	5.6	5.1	2.68	1.85	7.7	8.7	3.49	1.70	10.0	13.7	4.39	1.54	12.6	20.4
		25	1.95	1.95	5.6	5.1	2.68	2.03	7.7	8.7	3.49	1.88	10.0	13.7	4.38	1.73	12.6	20.4
		26	1.95	1.95	5.6	5.0	2.67	2.21	7.7	8.6	3.48	2.06	10.0	13.6	4.38	1.91	12.6	20.3
		27	1.94	1.94	5.6	5.0	2.67	2.39	7.7	8.6	3.47	2.24	10.0	13.6	4.37	2.09	12.6	20.3
		28	1.94	1.94	5.6	5.0	2.66	2.57	7.6	8.6	3.47	2.42	9.9	13.5	4.36	2.27	12.5	20.2
		29	1.93	1.93	5.6	5.0	2.66	2.66	7.6	8.6	3.46	2.60	9.9	13.5	4.36	2.45	12.5	20.2
	30	1.93	1.93	5.5	4.9	2.65	2.65	7.6	8.5	3.45	2.78	9.9	13.5	4.35	2.63	12.5	20.1	
	6	24	1.91	1.91	4.6	3.6	2.63	1.82	6.3	6.2	3.44	1.67	8.2	9.7	4.33	1.52	10.4	14.6
		25	1.90	1.90	4.5	3.5	2.62	2.01	6.3	6.1	3.43	1.86	8.2	9.7	4.33	1.71	10.4	14.5
		26	1.90	1.90	4.5	3.5	2.62	2.19	6.3	6.1	3.42	2.04	8.2	9.7	4.32	1.89	10.3	14.5
		27	1.89	1.89	4.5	3.5	2.61	2.37	6.2	6.1	3.42	2.22	8.2	9.6	4.31	2.07	10.3	14.4
		28	1.89	1.89	4.5	3.5	2.61	2.55	6.2	6.1	3.41	2.40	8.2	9.6	4.31	2.25	10.3	14.4
		29	1.88	1.88	4.5	3.5	2.60	2.60	6.2	6.0	3.40	2.58	8.1	9.6	4.30	2.43	10.3	14.3
	30	1.88	1.88	4.5	3.5	2.59	2.59	6.2	6.0	3.40	2.76	8.1	9.5	4.29	2.61	10.3	14.3	
	7	24	1.85	1.85	3.8	2.6	2.57	1.80	5.3	4.6	3.38	1.65	6.9	7.3	4.28	1.50	8.8	10.9
		25	1.85	1.85	3.8	2.6	2.57	1.98	5.3	4.5	3.37	1.83	6.9	7.2	4.27	1.68	8.8	10.9
		26	1.84	1.84	3.8	2.6	2.56	2.17	5.3	4.5	3.37	2.02	6.9	7.2	4.26	1.87	8.7	10.8
		27	1.84	1.84	3.8	2.6	2.56	2.35	5.2	4.5	3.36	2.20	6.9	7.2	4.25	2.05	8.7	10.8
		28	1.83	1.83	3.8	2.6	2.55	2.53	5.2	4.5	3.35	2.38	6.9	7.2	4.25	2.23	8.7	10.8
		29	1.83	1.83	3.7	2.5	2.55	2.55	5.2	4.5	3.35	2.56	6.9	7.1	4.24	2.41	8.7	10.7
	30	1.82	1.82	3.7	2.5	2.54	2.54	5.2	4.5	3.34	2.74	6.8	7.1	4.23	2.59	8.7	10.7	
	8	24	1.80	1.80	3.2	2.0	2.52	1.78	4.5	3.5	3.32	1.63	6.0	5.6	4.22	1.48	7.6	8.4
		25	1.80	1.80	3.2	2.0	2.51	1.96	4.5	3.5	3.32	1.81	5.9	5.6	4.21	1.66	7.6	8.4
26		1.79	1.79	3.2	2.0	2.51	2.14	4.5	3.5	3.31	2.00	5.9	5.6	4.20	1.84	7.5	8.4	
27		1.79	1.79	3.2	2.0	2.50	2.33	4.5	3.5	3.30	2.18	5.9	5.6	4.20	2.03	7.5	8.4	
28		1.78	1.78	3.2	1.9	2.50	2.50	4.5	3.4	3.30	2.36	5.9	5.5	4.19	2.21	7.5	8.3	
29		1.77	1.77	3.2	1.9	2.49	2.49	4.5	3.4	3.29	2.54	5.9	5.5	4.18	2.39	7.5	8.3	
30	1.77	1.77	3.2	1.9	2.48	2.48	4.5	3.4	3.28	2.72	5.9	5.5	4.17	2.57	7.5	8.3		

Note

- TC : Total capacity(W), SHC : Sensible Heat Capacity(W)
- Performances are based on the following conditions :
 - Cooling
 - Condition A : Inlet/Outlet Water Temp. 7°C / 12°C, Indoor Air Temp. 27°CDB / 19°CWB
 - Condition B : Inlet/Outlet Water Temp. 10°C / 15°C, Indoor Air Temp. 27°CDB / 19°CWB
 - Condition C : Inlet/Outlet Water Temp. 7°C / 12°C, Indoor Air Temp. 25°CDB / 17.9°CWB
 - Condition D : Inlet/Outlet Water Temp. 14°C / 18°C, Indoor Air Temp. 26°CDB / 18°CWB
- Above capacity tables shows representative values according to the change in temperature or water flow rate, etc., it may vary depending on the installation conditions and the surrounding environment.

6. Capacity Tables

Inlet Water Temp. (°C)	Water Temp Difference (°C)	Air Temp (°C DB)	Air Temp(17°C WB)				Air Temp(19°C WB)				Air Temp(21°C WB)				Air Temp(23°C WB)			
			TC (kW)	SHC (kW)	Water Flow Rate (LPM)	Pressure Drop (kPa)	TC (kW)	SHC (kW)	Water Flow Rate (LPM)	Pressure Drop (kPa)	TC (kW)	SHC (kW)	Water Flow Rate (LPM)	Pressure Drop (kPa)	TC (kW)	SHC (kW)	Water Flow Rate (LPM)	Pressure Drop (kPa)
9	4	24	2.48	2.21	8.9	14.6	3.35	2.11	12.0	24.5	4.31	2.01	15.5	38.1	5.38	1.91	19.3	56.1
		25	2.47	2.39	8.9	14.5	3.34	2.29	12.0	24.5	4.31	2.19	15.4	38.0	5.37	2.09	19.3	56.0
		26	2.47	2.47	8.9	14.5	3.34	2.47	12.0	24.4	4.30	2.37	15.4	37.9	5.36	2.27	19.2	55.9
		27	2.46	2.46	8.8	14.4	3.33	2.65	12.0	24.3	4.29	2.55	15.4	37.8	5.35	2.45	19.2	55.7
		28	2.46	2.46	8.8	14.3	3.33	2.83	11.9	24.2	4.29	2.74	15.4	37.7	5.35	2.64	19.2	55.6
		29	2.45	2.45	8.8	14.3	3.32	3.02	11.9	24.2	4.28	2.92	15.4	37.6	5.34	2.82	19.2	55.5
	30	2.45	2.45	8.8	14.2	3.31	3.20	11.9	24.1	4.27	3.10	15.3	37.5	5.33	3.00	19.1	55.3	
	5	24	2.41	2.18	6.9	9.5	3.28	2.08	9.4	16.1	4.25	1.98	12.2	25.2	5.31	1.88	15.2	37.1
		25	2.41	2.37	6.9	9.4	3.28	2.26	9.4	16.1	4.24	2.16	12.2	25.1	5.30	2.06	15.2	37.0
		26	2.40	2.40	6.9	9.4	3.27	2.45	9.4	16.0	4.23	2.35	12.2	25.0	5.29	2.25	15.2	37.0
		27	2.40	2.40	6.9	9.4	3.27	2.63	9.4	16.0	4.23	2.53	12.1	24.9	5.29	2.43	15.2	36.9
		28	2.39	2.39	6.9	9.3	3.26	2.81	9.4	15.9	4.22	2.71	12.1	24.9	5.28	2.61	15.2	36.8
		29	2.39	2.39	6.9	9.3	3.26	2.99	9.3	15.9	4.21	2.89	12.1	24.8	5.27	2.79	15.1	36.7
	30	2.38	2.38	6.8	9.3	3.25	3.17	9.3	15.8	4.21	3.07	12.1	24.7	5.26	2.97	15.1	36.6	
	6	24	2.35	2.16	5.6	6.6	3.22	2.06	7.7	11.4	4.18	1.96	10.0	17.8	5.24	1.86	12.5	26.4
		25	2.35	2.35	5.6	6.6	3.21	2.24	7.7	11.3	4.17	2.14	10.0	17.8	5.23	2.04	12.5	26.4
		26	2.34	2.34	5.6	6.6	3.21	2.42	7.7	11.3	4.17	2.32	10.0	17.7	5.23	2.22	12.5	26.3
		27	2.33	2.33	5.6	6.6	3.20	2.60	7.7	11.3	4.16	2.50	10.0	17.7	5.22	2.40	12.5	26.2
		28	2.33	2.33	5.6	6.5	3.20	2.78	7.6	11.2	4.15	2.68	9.9	17.6	5.21	2.58	12.5	26.2
		29	2.32	2.32	5.6	6.5	3.19	2.97	7.6	11.2	4.15	2.87	9.9	17.6	5.20	2.77	12.5	26.1
	30	2.32	2.32	5.5	6.5	3.18	3.15	7.6	11.2	4.14	3.05	9.9	17.5	5.20	2.95	12.4	26.0	
	7	24	2.29	2.13	4.7	4.9	3.15	2.03	6.5	8.4	4.11	1.93	8.4	13.3	5.17	1.83	10.6	19.8
		25	2.28	2.28	4.7	4.8	3.15	2.21	6.5	8.4	4.11	2.11	8.4	13.2	5.16	2.01	10.6	19.7
		26	2.28	2.28	4.7	4.8	3.14	2.39	6.4	8.4	4.10	2.29	8.4	13.2	5.16	2.19	10.6	19.7
		27	2.27	2.27	4.7	4.8	3.14	2.58	6.4	8.3	4.09	2.48	8.4	13.2	5.15	2.38	10.6	19.6
		28	2.27	2.27	4.6	4.8	3.13	2.76	6.4	8.3	4.09	2.66	8.4	13.1	5.14	2.56	10.6	19.6
		29	2.26	2.26	4.6	4.8	3.12	2.94	6.4	8.3	4.08	2.84	8.4	13.1	5.14	2.74	10.5	19.5
	30	2.26	2.26	4.6	4.7	3.12	3.12	6.4	8.3	4.07	3.02	8.4	13.1	5.13	2.92	10.5	19.5	
	8	24	2.22	2.11	4.0	3.7	3.09	2.01	5.5	6.5	4.04	1.91	7.3	10.3	5.10	1.80	9.2	15.3
		25	2.22	2.22	4.0	3.7	3.08	2.19	5.5	6.4	4.04	2.09	7.2	10.2	5.10	1.99	9.1	15.3
26		2.21	2.21	4.0	3.7	3.08	2.37	5.5	6.4	4.03	2.27	7.2	10.2	5.09	2.17	9.1	15.2	
27		2.21	2.21	4.0	3.6	3.07	2.55	5.5	6.4	4.03	2.45	7.2	10.2	5.08	2.35	9.1	15.2	
28		2.20	2.20	3.9	3.6	3.06	2.73	5.5	6.4	4.02	2.63	7.2	10.1	5.07	2.53	9.1	15.2	
29		2.20	2.20	3.9	3.6	3.06	2.91	5.5	6.4	4.01	2.81	7.2	10.1	5.07	2.71	9.1	15.1	
30	2.19	2.19	3.9	3.6	3.05	3.05	5.5	6.3	4.01	3.00	7.2	10.1	5.06	2.90	9.1	15.1		

Note

- TC : Total capacity(W), SHC : Sensible Heat Capacity(W)
- Performances are based on the following conditions :
 - Cooling
 - Condition A : Inlet/Outlet Water Temp. 7°C / 12°C, Indoor Air Temp. 27°CDB / 19°CWB
 - Condition B : Inlet/Outlet Water Temp. 10°C / 15°C, Indoor Air Temp. 27°CDB / 19°CWB
 - Condition C : Inlet/Outlet Water Temp. 7°C / 12°C, Indoor Air Temp. 25°CDB / 17.9°CWB
 - Condition D : Inlet/Outlet Water Temp. 14°C / 18°C, Indoor Air Temp. 26°CDB / 18°CWB
- Above capacity tables shows representative values according to the change in temperature or water flow rate, etc., it may vary depending on the installation conditions and the surrounding environment.

6. Capacity Tables

Inlet Water Temp. (°C)	Water Temp Difference (°C)	Air Temp (°C DB)	Air Temp(17°C WB)				Air Temp(19°C WB)				Air Temp(21°C WB)				Air Temp(23°C WB)			
			TC (kW)	SHC (kW)	Water Flow Rate (LPM)	Pressure Drop (kPa)	TC (kW)	SHC (kW)	Water Flow Rate (LPM)	Pressure Drop (kPa)	TC (kW)	SHC (kW)	Water Flow Rate (LPM)	Pressure Drop (kPa)	TC (kW)	SHC (kW)	Water Flow Rate (LPM)	Pressure Drop (kPa)
9	4	24	3.16	3.01	11.3	25.8	4.28	2.82	15.4	44.0	5.54	2.63	19.9	68.9	6.93	2.44	24.9	102.4
		25	3.15	3.15	11.3	25.7	4.28	3.08	15.3	43.8	5.53	2.89	19.8	68.7	6.92	2.70	24.8	102.1
		26	3.14	3.14	11.3	25.6	4.27	3.34	15.3	43.7	5.52	3.16	19.8	68.5	6.91	2.97	24.8	101.8
		27	3.13	3.13	11.2	25.5	4.26	3.60	15.3	43.5	5.51	3.42	19.8	68.3	6.90	3.23	24.8	101.5
		28	3.13	3.13	11.2	25.4	4.25	3.87	15.3	43.4	5.50	3.68	19.7	68.1	6.89	3.49	24.7	101.3
		29	3.12	3.12	11.2	25.3	4.24	4.13	15.2	43.2	5.49	3.94	19.7	67.9	6.88	3.75	24.7	101.0
	30	3.11	3.11	11.2	25.2	4.23	4.23	15.2	43.1	5.48	4.20	19.7	67.7	6.87	4.01	24.6	100.7	
	5	24	3.08	2.98	8.8	16.8	4.20	2.79	12.1	28.8	5.45	2.60	15.6	45.3	6.84	2.41	19.6	67.5
		25	3.07	3.07	8.8	16.7	4.19	3.05	12.0	28.7	5.44	2.86	15.6	45.2	6.83	2.67	19.6	67.3
		26	3.06	3.06	8.8	16.6	4.18	3.31	12.0	28.6	5.43	3.12	15.6	45.1	6.82	2.93	19.6	67.2
		27	3.05	3.05	8.8	16.6	4.18	3.57	12.0	28.5	5.42	3.38	15.6	44.9	6.81	3.19	19.6	67.0
		28	3.05	3.05	8.7	16.5	4.17	3.83	12.0	28.4	5.41	3.64	15.5	44.8	6.80	3.46	19.5	66.8
		29	3.04	3.04	8.7	16.4	4.16	4.09	11.9	28.3	5.40	3.91	15.5	44.7	6.79	3.72	19.5	66.6
	30	3.03	3.03	8.7	16.3	4.15	4.15	11.9	28.2	5.39	4.17	15.5	44.5	6.78	3.98	19.5	66.5	
	6	24	2.99	2.95	7.2	11.7	4.12	2.76	9.8	20.2	5.36	2.57	12.8	32.1	6.75	2.38	16.2	47.9
		25	2.99	2.99	7.1	11.6	4.11	3.02	9.8	20.2	5.35	2.83	12.8	32.0	6.74	2.64	16.1	47.8
		26	2.98	2.98	7.1	11.6	4.10	3.28	9.8	20.1	5.34	3.09	12.8	31.9	6.73	2.90	16.1	47.7
		27	2.97	2.97	7.1	11.5	4.09	3.54	9.8	20.0	5.34	3.35	12.8	31.8	6.72	3.16	16.1	47.5
		28	2.96	2.96	7.1	11.5	4.08	3.80	9.8	20.0	5.33	3.61	12.7	31.7	6.71	3.42	16.1	47.4
		29	2.96	2.96	7.1	11.4	4.07	4.07	9.7	19.9	5.32	3.87	12.7	31.6	6.70	3.68	16.0	47.3
	30	2.95	2.95	7.1	11.4	4.07	4.07	9.7	19.8	5.31	4.13	12.7	31.5	6.69	3.95	16.0	47.2	
	7	24	2.91	2.91	6.0	8.5	4.03	2.72	8.3	15.0	5.28	2.54	10.8	23.8	6.66	2.35	13.7	35.8
		25	2.90	2.90	6.0	8.5	4.02	2.99	8.2	14.9	5.27	2.80	10.8	23.8	6.65	2.61	13.6	35.7
		26	2.90	2.90	5.9	8.5	4.01	3.25	8.2	14.9	5.26	3.06	10.8	23.7	6.64	2.87	13.6	35.6
		27	2.89	2.89	5.9	8.4	4.01	3.51	8.2	14.8	5.25	3.32	10.8	23.6	6.63	3.13	13.6	35.5
		28	2.88	2.88	5.9	8.4	4.00	3.77	8.2	14.7	5.24	3.58	10.7	23.5	6.62	3.39	13.6	35.4
		29	2.87	2.87	5.9	8.4	3.99	3.99	8.2	14.7	5.23	3.84	10.7	23.5	6.61	3.65	13.6	35.3
	30	2.87	2.87	5.9	8.3	3.98	3.98	8.2	14.6	5.22	4.10	10.7	23.4	6.60	3.91	13.5	35.2	
	8	24	2.83	2.83	5.1	6.5	3.95	2.69	7.1	11.5	5.19	2.50	9.3	18.4	6.57	2.31	11.8	27.7
		25	2.82	2.82	5.1	6.4	3.94	2.95	7.1	11.4	5.18	2.76	9.3	18.3	6.56	2.57	11.8	27.6
26		2.81	2.81	5.0	6.4	3.93	3.21	7.0	11.4	5.17	3.02	9.3	18.3	6.55	2.84	11.8	27.5	
27		2.80	2.80	5.0	6.4	3.92	3.47	7.0	11.3	5.16	3.29	9.3	18.2	6.54	3.10	11.7	27.4	
28		2.80	2.80	5.0	6.4	3.91	3.74	7.0	11.3	5.15	3.55	9.2	18.1	6.53	3.36	11.7	27.4	
29		2.79	2.79	5.0	6.3	3.90	3.90	7.0	11.3	5.14	3.81	9.2	18.1	6.52	3.62	11.7	27.3	
30	2.78	2.78	5.0	6.3	3.90	3.90	7.0	11.2	5.13	4.07	9.2	18.0	6.51	3.88	11.7	27.2		

Note

1. TC : Total capacity(W), SHC : Sensible Heat Capacity(W)
2. Performances are based on the following conditions :
 - 1) Cooling
 - Condition A : Inlet/Outlet Water Temp. 7°C / 12°C, Indoor Air Temp. 27°CDB / 19°CWB
 - Condition B : Inlet/Outlet Water Temp. 10°C / 15°C, Indoor Air Temp. 27°CDB / 19°CWB
 - Condition C : Inlet/Outlet Water Temp. 7°C / 12°C, Indoor Air Temp. 25°CDB / 17.9°CWB
 - Condition D : Inlet/Outlet Water Temp. 14°C / 18°C, Indoor Air Temp. 26°CDB / 18°CWB
3. Above capacity tables shows representative values according to the change in temperature or water flow rate, etc., it may vary depending on the installation conditions and the surrounding environment.

6. Capacity Tables

Inlet Water Temp. (°C)	Water Temp Difference (°C)	Air Temp (°C DB)	Air Temp(17°C WB)				Air Temp(19°C WB)				Air Temp(21°C WB)				Air Temp(23°C WB)			
			TC (kW)	SHC (kW)	Water Flow Rate (LPM)	Pressure Drop (kPa)	TC (kW)	SHC (kW)	Water Flow Rate (LPM)	Pressure Drop (kPa)	TC (kW)	SHC (kW)	Water Flow Rate (LPM)	Pressure Drop (kPa)	TC (kW)	SHC (kW)	Water Flow Rate (LPM)	Pressure Drop (kPa)
9	4	24	4.17	3.97	15.0	35.6	5.66	3.73	20.3	60.8	7.31	3.48	26.2	95.6	9.15	3.23	32.8	142.2
		25	4.16	4.16	14.9	35.5	5.64	4.07	20.3	60.6	7.30	3.82	26.2	95.3	9.13	3.57	32.8	141.8
		26	4.15	4.15	14.9	35.3	5.63	4.41	20.2	60.4	7.28	4.16	26.1	95.0	9.12	3.92	32.7	141.5
		27	4.14	4.14	14.8	35.2	5.62	4.76	20.2	60.2	7.27	4.51	26.1	94.7	9.10	4.26	32.7	141.1
		28	4.13	4.13	14.8	35.0	5.61	5.10	20.1	60.0	7.26	4.85	26.1	94.5	9.09	4.60	32.6	140.7
		29	4.12	4.12	14.8	34.9	5.60	5.45	20.1	59.8	7.25	5.20	26.0	94.2	9.08	4.95	32.6	140.3
	30	4.11	4.11	14.7	34.7	5.59	5.59	20.1	59.6	7.23	5.54	26.0	93.9	9.06	5.29	32.5	140.0	
	5	24	4.06	3.93	11.7	23.1	5.54	3.68	15.9	39.7	7.19	3.43	20.7	62.7	9.03	3.18	25.9	93.6
		25	4.05	4.05	11.6	23.0	5.53	4.03	15.9	39.6	7.18	3.78	20.6	62.5	9.01	3.53	25.9	93.4
		26	4.04	4.04	11.6	22.9	5.52	4.37	15.9	39.4	7.17	4.12	20.6	62.3	9.00	3.87	25.8	93.1
		27	4.03	4.03	11.6	22.8	5.51	4.72	15.8	39.3	7.16	4.47	20.5	62.2	8.99	4.22	25.8	92.9
		28	4.02	4.02	11.5	22.7	5.50	5.06	15.8	39.2	7.15	4.81	20.5	62.0	8.97	4.56	25.8	92.6
		29	4.01	4.01	11.5	22.6	5.49	5.40	15.8	39.0	7.13	5.16	20.5	61.8	8.96	4.91	25.7	92.4
	30	4.00	4.00	11.5	22.5	5.48	5.48	15.7	38.9	7.12	5.50	20.4	61.6	8.95	5.25	25.7	92.1	
	6	24	3.95	3.89	9.5	16.0	5.43	3.64	13.0	27.9	7.08	3.39	16.9	44.3	8.91	3.14	21.3	66.3
		25	3.94	3.94	9.4	16.0	5.42	3.98	13.0	27.8	7.07	3.73	16.9	44.1	8.90	3.48	21.3	66.1
		26	3.93	3.93	9.4	15.9	5.41	4.33	12.9	27.7	7.06	4.08	16.9	44.0	8.88	3.83	21.3	66.0
		27	3.92	3.92	9.4	15.8	5.40	4.67	12.9	27.6	7.04	4.42	16.8	43.9	8.87	4.17	21.2	65.8
		28	3.91	3.91	9.4	15.8	5.39	5.02	12.9	27.5	7.03	4.77	16.8	43.7	8.86	4.52	21.2	65.6
		29	3.90	3.90	9.3	15.7	5.38	5.38	12.9	27.4	7.02	5.11	16.8	43.6	8.84	4.86	21.2	65.4
	30	3.89	3.89	9.3	15.6	5.37	5.37	12.8	27.3	7.01	5.46	16.8	43.5	8.83	5.21	21.1	65.2	
	7	24	3.84	3.84	7.9	11.7	5.32	3.60	10.9	20.6	6.96	3.35	14.3	32.9	8.79	3.10	18.0	49.4
		25	3.83	3.83	7.9	11.7	5.31	3.94	10.9	20.5	6.95	3.69	14.3	32.8	8.78	3.44	18.0	49.3
		26	3.82	3.82	7.8	11.6	5.30	4.29	10.9	20.4	6.94	4.04	14.2	32.6	8.76	3.79	18.0	49.1
		27	3.81	3.81	7.8	11.5	5.29	4.63	10.8	20.3	6.93	4.38	14.2	32.5	8.75	4.13	17.9	49.0
		28	3.80	3.80	7.8	11.5	5.28	4.97	10.8	20.3	6.92	4.73	14.2	32.4	8.74	4.48	17.9	48.9
		29	3.79	3.79	7.8	11.4	5.27	5.27	10.8	20.2	6.90	5.07	14.2	32.3	8.72	4.82	17.9	48.7
	30	3.78	3.78	7.8	11.4	5.25	5.25	10.8	20.1	6.89	5.41	14.1	32.2	8.71	5.17	17.9	48.6	
	8	24	3.73	3.73	6.7	8.9	5.21	3.55	9.3	15.7	6.85	3.30	12.3	25.3	8.67	3.05	15.6	38.2
		25	3.72	3.72	6.7	8.8	5.20	3.90	9.3	15.7	6.84	3.65	12.3	25.2	8.66	3.40	15.5	38.1
26		3.71	3.71	6.7	8.8	5.19	4.24	9.3	15.6	6.82	3.99	12.2	25.1	8.64	3.74	15.5	38.0	
27		3.70	3.70	6.6	8.7	5.17	4.59	9.3	15.5	6.81	4.34	12.2	25.0	8.63	4.09	15.5	37.9	
28		3.69	3.69	6.6	8.7	5.16	4.93	9.3	15.5	6.80	4.68	12.2	25.0	8.62	4.43	15.5	37.7	
29		3.68	3.68	6.6	8.7	5.15	5.15	9.2	15.4	6.79	5.03	12.2	24.9	8.60	4.78	15.4	37.6	
30	3.67	3.67	6.6	8.6	5.14	5.14	9.2	15.4	6.77	5.37	12.2	24.8	8.59	5.12	15.4	37.5		

Note

- TC : Total capacity(W), SHC : Sensible Heat Capacity(W)
- Performances are based on the following conditions :
 - Cooling
 - Condition A : Inlet/Outlet Water Temp. 7°C / 12°C, Indoor Air Temp. 27°CDB / 19°CWB
 - Condition B : Inlet/Outlet Water Temp. 10°C / 15°C, Indoor Air Temp. 27°CDB / 19°CWB
 - Condition C : Inlet/Outlet Water Temp. 7°C / 12°C, Indoor Air Temp. 25°CDB / 17.9°CWB
 - Condition D : Inlet/Outlet Water Temp. 14°C / 18°C, Indoor Air Temp. 26°CDB / 18°CWB
- Above capacity tables shows representative values according to the change in temperature or water flow rate, etc., it may vary depending on the installation conditions and the surrounding environment.

6. Capacity Tables

6.2 Heating Capacity

◆ WFC A012RG0A

Water Temp Difference (°C)	Air Temp (°C DB)	Inlet Water Temp.(°C)														
		40			45			50			55			60		
		TC (kW)	Water Flow Rate (LPM)	Pressure Drop (kPa)	TC (kW)	Water Flow Rate (LPM)	Pressure Drop (kPa)	TC (kW)	Water Flow Rate (LPM)	Pressure Drop (kPa)	TC (kW)	Water Flow Rate (LPM)	Pressure Drop (kPa)	TC (kW)	Water Flow Rate (LPM)	Pressure Drop (kPa)
4	16	1.93	6.9	6.1	2.35	8.4	8.5	2.77	9.9	11.3	3.18	11.4	14.4	3.60	12.9	17.8
	18	1.77	6.3	5.2	2.18	7.8	7.5	2.60	9.3	10.1	3.02	10.8	13.1	3.43	12.3	16.4
	20	1.60	5.7	4.4	2.02	7.2	6.5	2.43	8.7	9.0	2.85	10.2	11.9	3.27	11.7	15.1
	22	1.43	5.1	3.6	1.85	6.6	5.6	2.27	8.1	8.0	2.68	9.6	10.7	3.10	11.1	13.8
	24	1.27	4.5	3.0	1.68	6.0	4.8	2.10	7.5	7.0	2.52	9.0	9.6	2.93	10.5	12.5
5	16	1.92	5.5	4.1	2.33	6.7	5.7	2.75	7.9	7.6	3.17	9.1	9.7	3.58	10.3	12.0
	18	1.75	5.0	3.5	2.17	6.2	5.0	2.58	7.4	6.8	3.00	8.6	8.8	3.42	9.8	11.1
	20	1.58	4.5	3.0	2.00	5.7	4.4	2.42	6.9	6.1	2.83	8.1	8.0	3.25	9.3	10.1
	22	1.42	4.1	2.4	1.83	5.3	3.8	2.25	6.5	5.4	2.67	7.7	7.2	3.08	8.9	9.3
	24	1.25	3.6	2.0	1.67	4.8	3.2	2.08	6.0	4.7	2.50	7.2	6.4	2.92	8.4	8.4
6	16	1.90	4.5	3.0	2.32	5.5	4.1	2.73	6.5	5.5	3.15	7.5	7.0	3.57	8.5	8.7
	18	1.73	4.1	2.5	2.15	5.1	3.6	2.57	6.1	4.9	2.98	7.1	6.4	3.40	8.1	8.0
	20	1.57	3.7	2.1	1.98	4.7	3.2	2.40	5.7	4.4	2.82	6.7	5.8	3.23	7.7	7.3
	22	1.40	3.3	1.8	1.82	4.3	2.7	2.23	5.3	3.9	2.65	6.3	5.2	3.07	7.3	6.7
	24	1.23	3.0	1.4	1.65	3.9	2.3	2.07	4.9	3.4	2.48	5.9	4.7	2.90	6.9	6.1
7	16	1.88	3.9	2.2	2.30	4.7	3.1	2.72	5.6	4.2	3.13	6.4	5.3	3.55	7.3	6.6
	18	1.72	3.5	1.9	2.13	4.4	2.8	2.55	5.2	3.8	2.97	6.1	4.9	3.38	6.9	6.1
	20	1.55	3.2	1.6	1.97	4.0	2.4	2.38	4.9	3.3	2.80	5.7	4.4	3.22	6.6	5.6
	22	1.38	2.8	1.3	1.80	3.7	2.1	2.22	4.5	3.0	2.63	5.4	4.0	3.05	6.3	5.1
	24	1.22	2.5	1.0	1.63	3.3	1.8	2.05	4.2	2.6	2.47	5.1	3.5	2.88	5.9	4.6
8	16	1.87	3.3	1.8	2.28	4.1	2.5	2.70	4.8	3.3	3.12	5.6	4.2	3.53	6.3	5.2
	18	1.70	3.1	1.5	2.12	3.8	2.2	2.53	4.5	3.0	2.95	5.3	3.8	3.37	6.0	4.8
	20	1.53	2.8	1.2	1.95	3.5	1.9	2.37	4.2	2.6	2.78	5.0	3.5	3.20	5.7	4.4
	22	1.37	2.5	.9	1.78	3.2	1.6	2.20	3.9	2.3	2.62	4.7	3.1	3.03	5.4	4.0
	24	1.20	2.2	.6	1.62	2.9	1.4	2.03	3.6	2.0	2.45	4.4	2.8	2.87	5.1	3.6

Note

- TC : Total capacity(W)
- Performances are based on the following conditions :
 - Heating
 - Condition A : Inlet/Outlet Water Temp. 45°C / 40°C, Indoor Air Temp. 20°CDB / 15°CWB
 - Condition B : Inlet Water Temp. 50°C, Indoor Air Temp. 20°CDB / 15°CWB
- Above capacity tables shows representative values according to the change in temperature or water flow rate, etc., it may vary depending on the installation conditions and the surrounding environment.

◆ WFC A018RG0A

Water Temp Difference (°C)	Air Temp (°C DB)	Inlet Water Temp.(°C)														
		40			45			50			55			60		
		TC (kW)	Water Flow Rate (LPM)	Pressure Drop (kPa)	TC (kW)	Water Flow Rate (LPM)	Pressure Drop (kPa)	TC (kW)	Water Flow Rate (LPM)	Pressure Drop (kPa)	TC (kW)	Water Flow Rate (LPM)	Pressure Drop (kPa)	TC (kW)	Water Flow Rate (LPM)	Pressure Drop (kPa)
4	16	2.71	9.7	11.8	3.29	11.8	16.5	3.87	13.9	22.0	4.46	16.0	28.1	-	-	-
	18	2.47	8.9	10.1	3.06	11.0	14.6	3.64	13.1	19.7	4.22	15.2	25.6	-	-	-
	20	2.24	8.0	8.5	2.82	10.1	12.7	3.41	12.2	17.6	3.99	14.3	23.1	4.57	16.4	29.4
	22	2.01	7.2	7.0	2.59	9.3	10.9	3.17	11.4	15.5	3.76	13.5	20.8	4.34	15.6	26.8
	24	1.77	6.4	5.7	2.36	8.5	9.3	2.94	10.6	13.6	3.52	12.6	18.6	4.11	14.7	24.3
5	16	2.68	7.7	7.9	3.27	9.4	11.1	3.85	11.1	14.7	4.43	12.7	18.8	5.02	14.4	23.4
	18	2.45	7.0	6.8	3.03	8.7	9.8	3.62	10.4	13.2	4.20	12.1	17.2	4.78	13.7	21.5
	20	2.22	6.4	5.7	2.80	8.0	8.5	3.38	9.7	11.8	3.97	11.4	15.5	4.55	13.1	19.7
	22	1.98	5.7	4.7	2.57	7.4	7.3	3.15	9.0	10.4	3.73	10.7	14.0	4.32	12.4	18.0
	24	1.75	5.0	3.8	2.33	6.7	6.2	2.92	8.4	9.1	3.50	10.0	12.5	4.08	11.7	16.3
6	16	2.66	6.4	5.7	3.24	7.8	8.0	3.83	9.2	10.6	4.41	10.6	13.6	4.99	11.9	16.9
	18	2.43	5.8	4.9	3.01	7.2	7.0	3.59	8.6	9.5	4.18	10.0	12.4	4.76	11.4	15.5
	20	2.19	5.2	4.1	2.78	6.6	6.1	3.36	8.0	8.5	3.94	9.4	11.2	4.53	10.8	14.2
	22	1.96	4.7	3.4	2.54	6.1	5.3	3.13	7.5	7.5	3.71	8.9	10.1	4.29	10.3	13.0
	24	1.73	4.1	2.7	2.31	5.5	4.5	2.89	6.9	6.6	3.48	8.3	9.0	4.06	9.7	11.8
7	16	2.64	5.4	4.3	3.22	6.6	6.1	3.80	7.8	8.1	4.39	9.0	10.3	4.97	10.2	12.8
	18	2.40	4.9	3.7	2.99	6.1	5.3	3.57	7.3	7.2	4.15	8.5	9.4	4.74	9.7	11.8
	20	2.17	4.4	3.1	2.75	5.6	4.6	3.34	6.8	6.4	3.92	8.0	8.5	4.50	9.2	10.8
	22	1.94	4.0	2.5	2.52	5.2	4.0	3.10	6.4	5.7	3.69	7.6	7.6	4.27	8.8	9.9
	24	1.70	3.5	2.1	2.29	4.7	3.4	2.87	5.9	5.0	3.45	7.1	6.8	4.04	8.3	8.9
8	16	2.61	4.7	3.4	3.20	5.7	4.8	3.78	6.8	6.3	4.36	7.8	8.1	4.95	8.9	10.1
	18	2.38	4.3	2.9	2.96	5.3	4.2	3.55	6.4	5.7	4.13	7.4	7.4	4.71	8.5	9.3
	20	2.15	3.9	2.4	2.73	4.9	3.6	3.31	5.9	5.1	3.90	7.0	6.7	4.48	8.0	8.5
	22	1.91	3.4	2.0	2.50	4.5	3.1	3.08	5.5	4.5	3.66	6.6	6.0	4.25	7.6	7.8
	24	1.68	3.0	1.6	2.26	4.1	2.6	2.85	5.1	3.9	3.43	6.2	5.4	4.01	7.2	7.0

Note

- TC : Total capacity(W)
- Performances are based on the following conditions :
 - Heating
 - Condition A : Inlet/Outlet Water Temp. 45°C / 40°C, Indoor Air Temp. 20°CDB / 15°CWB
 - Condition B : Inlet Water Temp. 50°C, Indoor Air Temp. 20°CDB / 15°CWB
- Above capacity tables shows representative values according to the change in temperature or water flow rate, etc., it may vary depending on the installation conditions and the surrounding environment.

6. Capacity Tables

◆ WFCA025RG0A

Water Temp Difference (°C)	Air Temp (°C DB)	Inlet Water Temp.(°C)														
		40			45			50			55			60		
		TC (kW)	Water Flow Rate (LPM)	Pressure Drop (kPa)	TC (kW)	Water Flow Rate (LPM)	Pressure Drop (kPa)	TC (kW)	Water Flow Rate (LPM)	Pressure Drop (kPa)	TC (kW)	Water Flow Rate (LPM)	Pressure Drop (kPa)	TC (kW)	Water Flow Rate (LPM)	Pressure Drop (kPa)
4	16	3.09	11.1	17.4	3.76	13.5	24.4	4.43	15.9	32.4	5.09	18.3	41.4	-	-	-
	18	2.83	10.1	14.8	3.49	12.5	21.4	4.16	14.9	29.1	4.83	17.3	37.7	-	-	-
	20	2.56	9.2	12.5	3.23	11.6	18.7	3.89	14.0	25.9	4.56	16.4	34.1	5.23	18.8	43.4
	22	2.29	8.2	10.3	2.96	10.6	16.1	3.63	13.0	22.9	4.29	15.4	30.7	4.96	17.8	39.6
	24	2.03	7.3	8.4	2.69	9.7	13.6	3.36	12.1	20.0	4.03	14.4	27.5	4.69	16.8	35.9
5	16	3.07	8.8	11.6	3.73	10.7	16.3	4.40	12.6	21.7	5.07	14.5	27.8	5.73	16.5	34.5
	18	2.80	8.0	9.9	3.47	10.0	14.4	4.13	11.9	19.5	4.80	13.8	25.3	5.47	15.7	31.7
	20	2.53	7.3	8.4	3.20	9.2	12.5	3.87	11.1	17.4	4.53	13.0	22.9	5.20	14.9	29.1
	22	2.27	6.5	6.9	2.93	8.4	10.8	3.60	10.3	15.3	4.27	12.2	20.6	4.93	14.2	26.5
	24	2.00	5.7	5.6	2.67	7.7	9.1	3.33	9.6	13.4	4.00	11.5	18.4	4.67	13.4	24.1
6	16	3.04	7.3	8.4	3.71	8.9	11.8	4.37	10.5	15.7	5.04	12.1	20.0	5.71	13.7	24.9
	18	2.77	6.6	7.1	3.44	8.2	10.3	4.11	9.8	14.0	4.77	11.4	18.2	5.44	13.0	22.9
	20	2.51	6.0	6.0	3.17	7.6	9.0	3.84	9.2	12.5	4.51	10.8	16.5	5.17	12.4	21.0
	22	2.24	5.4	5.0	2.91	7.0	7.7	3.57	8.5	11.0	4.24	10.1	14.8	4.91	11.7	19.1
	24	1.97	4.7	4.0	2.64	6.3	6.6	3.31	7.9	9.7	3.97	9.5	13.3	4.64	11.1	17.4
7	16	3.01	6.2	6.3	3.68	7.5	8.9	4.35	8.9	11.9	5.01	10.3	15.2	5.68	11.6	18.9
	18	2.75	5.6	5.4	3.41	7.0	7.8	4.08	8.4	10.6	4.75	9.7	13.8	5.41	11.1	17.4
	20	2.48	5.1	4.5	3.15	6.5	6.8	3.81	7.8	9.5	4.48	9.2	12.5	5.15	10.6	15.9
	22	2.21	4.5	3.7	2.88	5.9	5.8	3.55	7.3	8.4	4.21	8.6	11.2	4.88	10.0	14.5
	24	1.95	4.0	3.0	2.61	5.4	5.0	3.28	6.7	7.3	3.95	8.1	10.0	4.61	9.5	13.2
8	16	2.99	5.4	5.0	3.65	6.6	7.0	4.32	7.8	9.3	4.99	8.9	11.9	5.65	10.1	14.8
	18	2.72	4.9	4.2	3.39	6.1	6.1	4.05	7.3	8.4	4.72	8.5	10.9	5.39	9.7	13.6
	20	2.45	4.4	3.5	3.12	5.6	5.3	3.79	6.8	7.4	4.45	8.0	9.8	5.12	9.2	12.5
	22	2.19	3.9	2.9	2.85	5.1	4.6	3.52	6.3	6.6	4.19	7.5	8.8	4.85	8.7	11.4
	24	1.92	3.4	2.3	2.59	4.6	3.9	3.25	5.8	5.7	3.92	7.0	7.9	4.59	8.2	10.3

Note

- TC : Total capacity(W)
- Performances are based on the following conditions :
 - Heating
 - Condition A : Inlet/Outlet Water Temp. 45°C / 40°C, Indoor Air Temp. 20°CDB / 15°CWB
 - Condition B : Inlet Water Temp. 50°C, Indoor Air Temp. 20°CDB / 15°CWB
- Above capacity tables shows representative values according to the change in temperature or water flow rate, etc., it may vary depending on the installation conditions and the surrounding environment.

◆ WFCA032RG0A

Water Temp Difference (°C)	Air Temp (°C DB)	Inlet Water Temp.(°C)														
		40			45			50			55			60		
		TC (kW)	Water Flow Rate (LPM)	Pressure Drop (kPa)	TC (kW)	Water Flow Rate (LPM)	Pressure Drop (kPa)	TC (kW)	Water Flow Rate (LPM)	Pressure Drop (kPa)	TC (kW)	Water Flow Rate (LPM)	Pressure Drop (kPa)	TC (kW)	Water Flow Rate (LPM)	Pressure Drop (kPa)
4	16	3.67	13.2	24.7	4.47	16.0	34.8	-	-	-	-	-	-	-	-	-
	18	3.36	12.0	21.1	4.15	14.9	30.6	4.94	17.7	41.5	-	-	-	-	-	-
	20	3.04	10.9	17.8	3.83	13.8	26.6	4.62	16.6	37.0	-	-	-	-	-	-
	22	2.72	9.8	14.7	3.52	12.6	22.9	4.31	15.5	32.7	5.10	18.3	43.9	-	-	-
	24	2.41	8.6	11.9	3.20	11.5	19.4	3.99	14.3	28.6	4.78	17.2	39.2	-	-	-
5	16	3.64	10.5	16.5	4.43	12.7	23.3	5.23	15.0	31.0	6.02	17.3	39.7	-	-	-
	18	3.33	9.5	14.1	4.12	11.8	20.5	4.91	14.1	27.8	5.70	16.4	36.1	-	-	-
	20	3.01	8.6	11.9	3.80	10.9	17.8	4.59	13.2	24.7	5.38	15.5	32.7	6.18	17.7	41.5
	22	2.69	7.7	9.8	3.48	10.0	15.3	4.28	12.3	21.8	5.07	14.5	29.4	5.86	16.8	37.9
	24	2.38	6.8	7.9	3.17	9.1	13.0	3.96	11.4	19.1	4.75	13.6	26.2	5.54	15.9	34.4
6	16	3.61	8.6	11.9	4.40	10.5	16.7	5.19	12.4	22.3	5.99	14.3	28.6	6.78	16.2	35.5
	18	3.29	7.9	10.1	4.09	9.8	14.7	4.88	11.7	20.0	5.67	13.6	26.0	6.46	15.5	32.7
	20	2.98	7.1	8.5	3.77	9.0	12.8	4.56	10.9	17.8	5.35	12.8	23.5	6.14	14.7	29.9
	22	2.66	6.4	7.0	3.45	8.3	11.0	4.24	10.2	15.7	5.04	12.0	21.1	5.83	13.9	27.3
	24	2.34	5.6	5.7	3.14	7.5	9.3	3.93	9.4	13.7	4.72	11.3	18.9	5.51	13.2	24.7
7	16	3.58	7.3	9.0	4.37	9.0	12.7	5.16	10.6	16.9	5.95	12.2	21.6	6.75	13.8	26.9
	18	3.26	6.7	7.7	4.05	8.3	11.1	4.85	9.9	15.1	5.64	11.6	19.7	6.43	13.2	24.7
	20	2.95	6.0	6.4	3.74	7.7	9.7	4.53	9.3	13.5	5.32	10.9	17.8	6.11	12.5	22.7
	22	2.63	5.4	5.3	3.42	7.0	8.3	4.21	8.6	11.9	5.00	10.3	16.0	5.80	11.9	20.7
	24	2.31	4.7	4.2	3.10	6.4	7.0	3.90	8.0	10.4	4.69	9.6	14.3	5.48	11.2	18.7
8	16	3.55	6.4	7.0	4.34	7.8	9.9	5.13	9.2	13.3	5.92	10.6	17.0	6.71	12.0	21.1
	18	3.23	5.8	6.0	4.02	7.2	8.7	4.81	8.6	11.9	5.61	10.1	15.5	6.40	11.5	19.4
	20	2.91	5.2	5.0	3.71	6.6	7.6	4.50	8.1	10.6	5.29	9.5	14.0	6.08	10.9	17.8
	22	2.60	4.7	4.1	3.39	6.1	6.5	4.18	7.5	9.3	4.97	8.9	12.6	5.76	10.3	16.2
	24	2.28	4.1	3.3	3.07	5.5	5.5	3.86	6.9	8.1	4.66	8.4	11.2	5.45	9.8	14.7

Note

- TC : Total capacity(W)
- Performances are based on the following conditions :
 - Heating
 - Condition A : Inlet/Outlet Water Temp. 45°C / 40°C, Indoor Air Temp. 20°CDB / 15°CWB
 - Condition B : Inlet Water Temp. 50°C, Indoor Air Temp. 20°CDB / 15°CWB
- Above capacity tables shows representative values according to the change in temperature or water flow rate, etc., it may vary depending on the installation conditions and the surrounding environment.

6. Capacity Tables

◆ WFCA039RG0A

Water Temp Difference (°C)	Air Temp (°C DB)	Inlet Water Temp.(°C)														
		40			45			50			55			60		
		TC (kW)	Water Flow Rate (LPM)	Pressure Drop (kPa)	TC (kW)	Water Flow Rate (LPM)	Pressure Drop (kPa)	TC (kW)	Water Flow Rate (LPM)	Pressure Drop (kPa)	TC (kW)	Water Flow Rate (LPM)	Pressure Drop (kPa)	TC (kW)	Water Flow Rate (LPM)	Pressure Drop (kPa)
4	16	4.06	14.6	42.1	4.94	17.7	59.3	5.81	20.8	79.0	6.69	24.0	101.2	7.56	27.1	125.7
	18	3.71	13.3	36.0	4.59	16.5	52.1	5.46	19.6	70.8	6.34	22.7	92.0	7.21	25.9	115.6
	20	3.36	12.1	30.3	4.24	15.2	45.4	5.11	18.3	63.0	5.99	21.5	83.2	6.86	24.6	105.9
	22	3.01	10.8	25.0	3.89	13.9	39.0	4.76	17.1	55.7	5.64	20.2	74.9	6.51	23.4	96.5
	24	2.66	9.5	20.2	3.54	12.7	33.1	4.41	15.8	48.7	5.29	19.0	66.9	6.16	22.1	87.6
5	16	4.03	11.6	28.1	4.90	14.1	39.6	5.78	16.6	52.8	6.65	19.1	67.7	7.53	21.6	84.1
	18	3.68	10.6	24.0	4.55	13.1	34.8	5.43	15.6	47.4	6.30	18.1	61.5	7.18	20.6	77.3
	20	3.33	9.5	20.2	4.20	12.1	30.3	5.08	14.6	42.1	5.95	17.1	55.7	6.83	19.6	70.8
	22	2.98	8.5	16.7	3.85	11.1	26.0	4.73	13.6	37.2	5.60	16.1	50.1	6.48	18.6	64.6
	24	2.63	7.5	13.4	3.50	10.0	22.1	4.38	12.6	32.5	5.25	15.1	44.7	6.13	17.6	58.6
6	16	3.99	9.5	20.2	4.87	11.6	28.5	5.74	13.7	38.0	6.62	15.8	48.7	7.49	17.9	60.5
	18	3.64	8.7	17.2	4.52	10.8	25.0	5.39	12.9	34.1	6.27	15.0	44.3	7.14	17.1	55.7
	20	3.29	7.9	14.5	4.17	10.0	21.8	5.04	12.1	30.3	5.92	14.2	40.1	6.79	16.2	51.0
	22	2.94	7.0	11.9	3.82	9.1	18.7	4.69	11.2	26.7	5.57	13.3	36.0	6.44	15.4	46.5
	24	2.59	6.2	9.6	3.47	8.3	15.8	4.34	10.4	23.4	5.22	12.5	32.2	6.09	14.6	42.1
7	16	3.96	8.1	15.2	4.83	9.9	21.5	5.71	11.7	28.7	6.58	13.5	36.9	7.46	15.3	45.8
	18	3.61	7.4	13.0	4.48	9.2	18.9	5.36	11.0	25.8	6.23	12.8	33.5	7.11	14.6	42.1
	20	3.26	6.7	10.9	4.13	8.5	16.4	5.01	10.3	22.9	5.88	12.1	30.3	6.76	13.9	38.6
	22	2.91	6.0	9.0	3.78	7.8	14.1	4.66	9.5	20.2	5.53	11.3	27.2	6.41	13.1	35.2
	24	2.56	5.2	7.2	3.43	7.0	11.9	4.31	8.8	17.6	5.18	10.6	24.3	6.06	12.4	31.9
8	16	3.92	7.0	11.9	4.80	8.6	16.9	5.67	10.2	22.6	6.55	11.7	28.9	7.42	13.3	36.0
	18	3.57	6.4	10.2	4.45	8.0	14.8	5.32	9.5	20.2	6.20	11.1	26.3	7.07	12.7	33.1
	20	3.22	5.8	8.5	4.10	7.3	12.9	4.97	8.9	18.0	5.85	10.5	23.8	6.72	12.1	30.3
	22	2.87	5.1	7.0	3.75	6.7	11.0	4.62	8.3	15.8	5.50	9.9	21.4	6.37	11.4	27.6
	24	2.52	4.5	5.6	3.40	6.1	9.3	4.27	7.7	13.8	5.15	9.2	19.1	6.02	10.8	25.0

Note

- TC : Total capacity(W)
- Performances are based on the following conditions :
 - Heating
 - Condition A : Inlet/Outlet Water Temp. 45°C / 40°C, Indoor Air Temp. 20°CDB / 15°CWB
 - Condition B : Inlet Water Temp. 50°C, Indoor Air Temp. 20°CDB / 15°CWB
- Above capacity tables shows representative values according to the change in temperature or water flow rate, etc., it may vary depending on the installation conditions and the surrounding environment.

◆ WFCA055RG0A

Water Temp Difference (°C)	Air Temp (°C DB)	Inlet Water Temp.(°C)														
		40			45			50			55			60		
		TC (kW)	Water Flow Rate (LPM)	Pressure Drop (kPa)	TC (kW)	Water Flow Rate (LPM)	Pressure Drop (kPa)	TC (kW)	Water Flow Rate (LPM)	Pressure Drop (kPa)	TC (kW)	Water Flow Rate (LPM)	Pressure Drop (kPa)	TC (kW)	Water Flow Rate (LPM)	Pressure Drop (kPa)
4	16	5.12	18.4	67.3	6.23	22.3	94.8	7.33	26.3	126.5	-	-	-	-	-	-
	18	4.68	16.8	57.4	5.79	20.8	83.3	6.89	24.7	113.4	-	-	-	-	-	-
	20	4.24	15.2	48.3	5.34	19.2	72.5	6.45	23.1	100.9	7.55	27.1	133.3	-	-	-
	22	3.80	13.6	39.9	4.90	17.6	62.3	6.01	21.6	89.0	7.11	25.5	119.9	-	-	-
	24	3.36	12.0	32.1	4.46	16.0	52.8	5.57	20.0	77.8	6.67	23.9	107.0	7.77	27.9	140.3
5	16	5.08	14.6	44.8	6.18	17.8	63.3	7.29	20.9	84.4	8.39	24.1	108.3	9.50	27.3	134.7
	18	4.64	13.3	38.3	5.74	16.5	55.6	6.85	19.7	75.7	7.95	22.8	98.4	9.05	26.0	123.8
	20	4.20	12.0	32.1	5.30	15.2	48.3	6.40	18.4	67.3	7.51	21.6	89.0	8.61	24.7	113.4
	22	3.75	10.8	26.5	4.86	13.9	41.5	5.96	17.1	59.4	7.07	20.3	80.0	8.17	23.5	103.3
	24	3.31	9.5	21.3	4.42	12.7	35.1	5.52	15.8	51.9	6.63	19.0	71.4	7.73	22.2	93.7
6	16	5.04	12.0	32.1	6.14	14.7	45.4	7.24	17.3	60.7	8.35	20.0	77.8	9.45	22.6	96.8
	18	4.59	11.0	27.4	5.70	13.6	39.9	6.80	16.3	54.3	7.91	18.9	70.7	9.01	21.6	89.0
	20	4.15	9.9	23.0	5.26	12.6	34.6	6.36	15.2	48.3	7.46	17.9	63.9	8.57	20.5	81.5
	22	3.71	8.9	18.9	4.81	11.5	29.7	5.92	14.2	42.6	7.02	16.8	57.4	8.13	19.4	74.2
	24	3.27	7.8	15.2	4.37	10.5	25.2	5.48	13.1	37.2	6.58	15.7	51.3	7.69	18.4	67.3
7	16	4.99	10.2	24.2	6.10	12.5	34.3	7.20	14.8	45.8	8.30	17.0	58.8	9.41	19.3	73.2
	18	4.55	9.3	20.6	5.65	11.6	30.1	6.76	13.9	41.0	7.86	16.1	53.4	8.97	18.4	67.3
	20	4.11	8.4	17.3	5.21	10.7	26.1	6.32	13.0	36.5	7.42	15.2	48.3	8.52	17.5	61.6
	22	3.67	7.5	14.2	4.77	9.8	22.4	5.87	12.0	32.1	6.98	14.3	43.4	8.08	16.6	56.1
	24	3.22	6.6	11.4	4.33	8.9	18.9	5.43	11.1	28.1	6.54	13.4	38.7	7.64	15.7	50.8
8	16	4.95	8.9	18.9	6.05	10.9	26.8	7.16	12.8	35.9	8.26	14.8	46.1	9.36	16.8	57.4
	18	4.51	8.1	16.1	5.61	10.1	23.5	6.71	12.0	32.1	7.82	14.0	41.9	8.92	16.0	52.8
	20	4.06	7.3	13.5	5.17	9.3	20.4	6.27	11.3	28.6	7.38	13.2	37.9	8.48	15.2	48.3
	22	3.62	6.5	11.1	4.73	8.5	17.5	5.83	10.5	25.2	6.93	12.4	34.0	8.04	14.4	44.0
	24	3.18	5.7	8.9	4.28	7.7	14.8	5.39	9.7	21.9	6.49	11.6	30.3	7.60	13.6	39.9

Note

- TC : Total capacity(W)
- Performances are based on the following conditions :
 - Heating
 - Condition A : Inlet/Outlet Water Temp. 45°C / 40°C, Indoor Air Temp. 20°CDB / 15°CWB
 - Condition B : Inlet Water Temp. 50°C, Indoor Air Temp. 20°CDB / 15°CWB
- Above capacity tables shows representative values according to the change in temperature or water flow rate, etc., it may vary depending on the installation conditions and the surrounding environment.

6. Capacity Tables

◆ WFC A066RG0A

Water Temp Difference (°C)	Air Temp (°C DB)	Inlet Water Temp.(°C)														
		40			45			50			55			60		
		TC (kW)	Water Flow Rate (LPM)	Pressure Drop (kPa)	TC (kW)	Water Flow Rate (LPM)	Pressure Drop (kPa)	TC (kW)	Water Flow Rate (LPM)	Pressure Drop (kPa)	TC (kW)	Water Flow Rate (LPM)	Pressure Drop (kPa)	TC (kW)	Water Flow Rate (LPM)	Pressure Drop (kPa)
4	16	6.38	22.9	100.0	7.76	27.8	141.2	-	-	-	-	-	-	-	-	-
	18	5.83	20.9	85.3	7.21	25.9	124.0	-	-	-	-	-	-	-	-	-
	20	5.28	18.9	71.7	6.66	23.9	107.8	-	-	-	-	-	-	-	-	-
	22	4.73	17.0	59.1	6.11	21.9	92.6	7.48	26.8	132.5	-	-	-	-	-	-
	24	4.18	15.0	47.6	5.56	19.9	78.4	6.93	24.9	115.8	-	-	-	-	-	-
5	16	6.33	18.2	66.5	7.70	22.1	94.0	9.08	26.1	125.7	-	-	-	-	-	-
	18	5.78	16.6	56.7	7.15	20.5	82.5	8.53	24.5	112.5	-	-	-	-	-	-
	20	5.23	15.0	47.6	6.60	18.9	71.7	7.98	22.9	100.0	9.35	26.8	132.5	-	-	-
	22	4.68	13.4	39.2	6.05	17.4	61.5	7.43	21.3	88.2	8.80	25.3	119.0	-	-	-
	24	4.13	11.8	31.5	5.50	15.8	52.1	6.88	19.7	77.0	8.25	23.7	106.2	9.63	27.6	139.5
6	16	6.27	15.0	47.6	7.65	18.3	67.4	9.02	21.6	90.1	10.40	24.9	115.8	11.77	28.2	144.2
	18	5.72	13.7	40.6	7.10	17.0	59.1	8.47	20.3	80.7	9.85	23.6	105.2	11.22	26.8	132.5
	20	5.17	12.4	34.0	6.55	15.7	51.3	7.92	18.9	71.7	9.30	22.2	95.0	10.67	25.5	121.2
	22	4.62	11.1	28.0	6.00	14.3	44.0	7.37	17.6	63.2	8.75	20.9	85.3	10.12	24.2	110.4
	24	4.07	9.7	22.5	5.45	13.0	37.2	6.82	16.3	55.2	8.20	19.6	76.1	9.57	22.9	100.0
7	16	6.22	12.7	35.8	7.59	15.6	50.8	8.97	18.4	68.0	10.34	21.2	87.4	11.72	24.0	108.9
	18	5.67	11.6	30.5	7.04	14.4	44.5	8.42	17.3	60.8	9.79	20.1	79.4	11.17	22.9	100.0
	20	5.12	10.5	25.5	6.49	13.3	38.6	7.87	16.1	54.1	9.24	18.9	71.7	10.62	21.8	91.5
	22	4.57	9.4	21.0	5.94	12.2	33.1	7.32	15.0	47.6	8.69	17.8	64.4	10.07	20.6	83.3
	24	4.02	8.2	16.8	5.39	11.1	28.0	6.77	13.9	41.5	8.14	16.7	57.4	9.52	19.5	75.5
8	16	6.16	11.1	28.0	7.54	13.5	39.7	8.91	16.0	53.2	10.29	18.5	68.5	11.66	20.9	85.3
	18	5.61	10.1	23.8	6.99	12.5	34.8	8.36	15.0	47.6	9.74	17.5	62.2	11.11	19.9	78.4
	20	5.06	9.1	19.9	6.44	11.5	30.2	7.81	14.0	42.3	9.19	16.5	56.1	10.56	18.9	71.7
	22	4.51	8.1	16.3	5.89	10.6	25.8	7.26	13.0	37.2	8.64	15.5	50.4	10.01	18.0	65.3
	24	3.96	7.1	13.0	5.34	9.6	21.8	6.71	12.0	32.5	8.09	14.5	44.9	9.46	17.0	59.1

Note

1. TC : Total capacity(W)
2. Performances are based on the following conditions :
 - 1) Heating
 - Condition A : Inlet/Outlet Water Temp. 45°C / 40°C, Indoor Air Temp. 20°CDB / 15°CWB
 - Condition B : Inlet Water Temp. 50°C, Indoor Air Temp. 20°CDB / 15°CWB
3. Above capacity tables shows representative values according to the change in temperature or water flow rate, etc., it may vary depending on the installation conditions and the surrounding environment.

7. External Static Pressure (E.S.P) & Air Flow

◆ WFC A012RG0A, WFC A018RG0A

Setting Value	Static Pressure(mmAq(Pa))					
	0 (0)	1 (10)	2 (20)	3 (29)	4 (39)	5 (49)
	Air Flow Rate (m ³ /min)					
60	-	-	-	-	-	-
65	5.03	-	-	-	-	-
70	5.60	4.85	-	-	-	-
75	6.19	5.44	4.57	-	-	-
80	6.79	6.05	5.17	-	-	-
85	7.41	6.67	5.80	4.80	-	-
90	8.05	7.31	6.43	5.44	-	-
95	8.71	7.96	7.09	6.09	4.97	-
100	9.38	8.63	7.76	6.76	5.64	-
105	10.07	9.32	8.45	7.45	6.33	5.08
110	-	10.03	9.16	8.16	7.04	5.79
115	-	-	9.88	8.88	7.76	6.51
120	-	-	-	9.62	8.50	7.25
125	-	-	-	10.38	9.26	8.01
130	-	-	-	-	10.03	8.78

Note

1. The above table shows the correlation between the air rates and E.S.P.
2. The above table shows the available E.S.P. range.
3. If the E.S.P. of the installed indoor is less than the lowest value(as mention in the table), indoor components can be failed.

◆ Fan Performance (WFC A012RG0A, WFC A018RG0A)

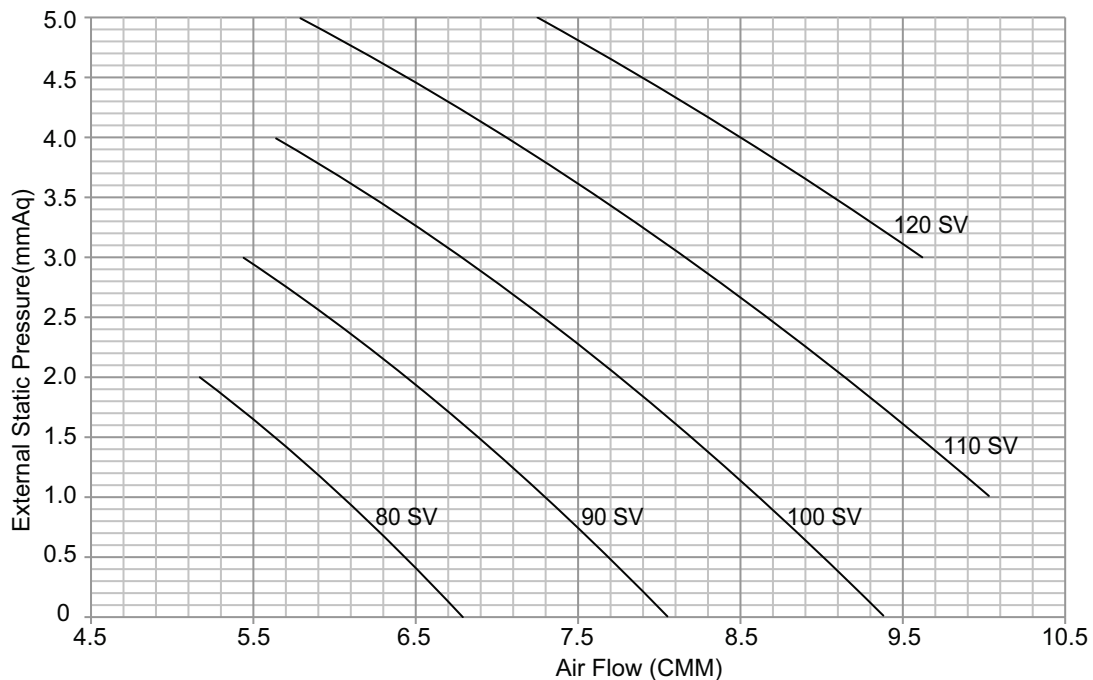

7. External Static Pressure (E.S.P) & Air Flow

◆ WFC A025RG0A, WFC A032RG0A

Setting Value	Static Pressure(mmAq(Pa))					
	0 (0)	1 (10)	2 (20)	3 (29)	4 (39)	5 (49)
	Air Flow Rate (m³/min)					
75	6.50	-	-	-	-	-
80	7.34	6.70	-	-	-	-
85	8.20	7.55	6.69	-	-	-
90	9.07	8.43	7.56	6.47	-	-
95	9.96	9.32	8.45	7.36	-	-
100	10.87	10.22	9.36	8.27	6.96	-
105	11.79	11.15	10.28	9.19	7.89	6.35
110	12.73	12.09	11.22	10.14	8.83	7.30
115	13.69	13.05	12.18	11.09	9.78	8.25
120	14.67	14.02	13.16	12.07	10.76	9.23
125	15.66	15.01	14.15	13.06	11.75	10.22
130	16.67	16.02	15.16	14.07	12.76	11.23
135	-	-	16.18	15.10	13.79	12.26

Note

1. The above table shows the correlation between the air rates and E.S.P.
2. The above table shows the available E.S.P. range.
3. If the E.S.P. of the installed indoor is less than the lowest value(as mention in the table), indoor components can be failed.

◆ Fan Performance (WFC A025RG0A, WFC A032RG0A)

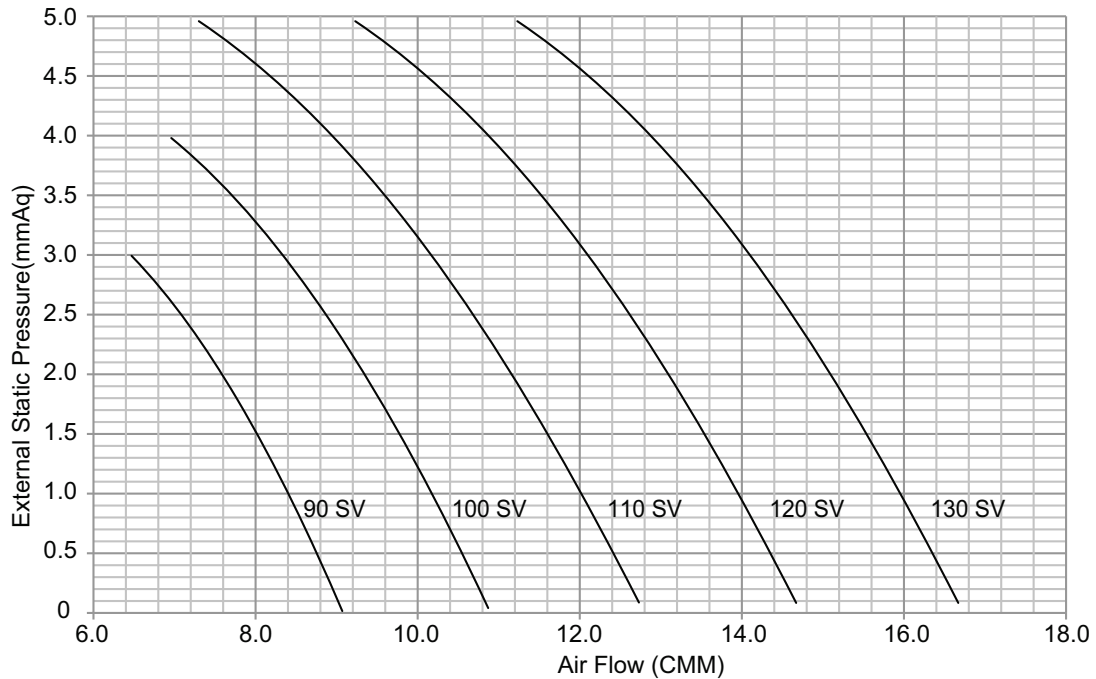

7. External Static Pressure (E.S.P) & Air Flow

◆ WFC A039RG0A WFC A055RG0A, WFC A066RG0A

Setting Value	Static Pressure(mmAq(Pa))					
	0 (0)	1 (10)	2 (20)	3 (29)	4 (39)	5 (49)
	Air Flow Rate (m ³ /min)					
85	10.19	-	-	-	-	-
90	12.18	10.71	11.09	-	-	-
95	13.81	12.34	12.19	-	-	-
100	15.16	13.69	13.38	10.71	-	-
105	16.30	14.83	14.36	11.85	-	-
110	17.31	15.85	15.23	12.86	10.97	-
115	18.27	16.80	16.07	13.82	11.93	-
120	19.26	17.79	16.93	14.80	12.91	10.49
125	20.34	18.87	17.89	15.88	13.99	11.57
130	21.60	20.13	19.01	17.14	15.25	12.83
135	-	21.64	20.36	18.66	16.76	14.35
139	-	-	21.08	20.00	17.34	15.29

Note

1. The above table shows the correlation between the air rates and E.S.P.
2. The above table shows the available E.S.P. range.
3. If the E.S.P. of the installed indoor is less than the lowest value(as mention in the table), indoor components can be failed.

◆ Fan Performance (WFC A039RG0A WFC A055RG0A, WFC A066RG0A)

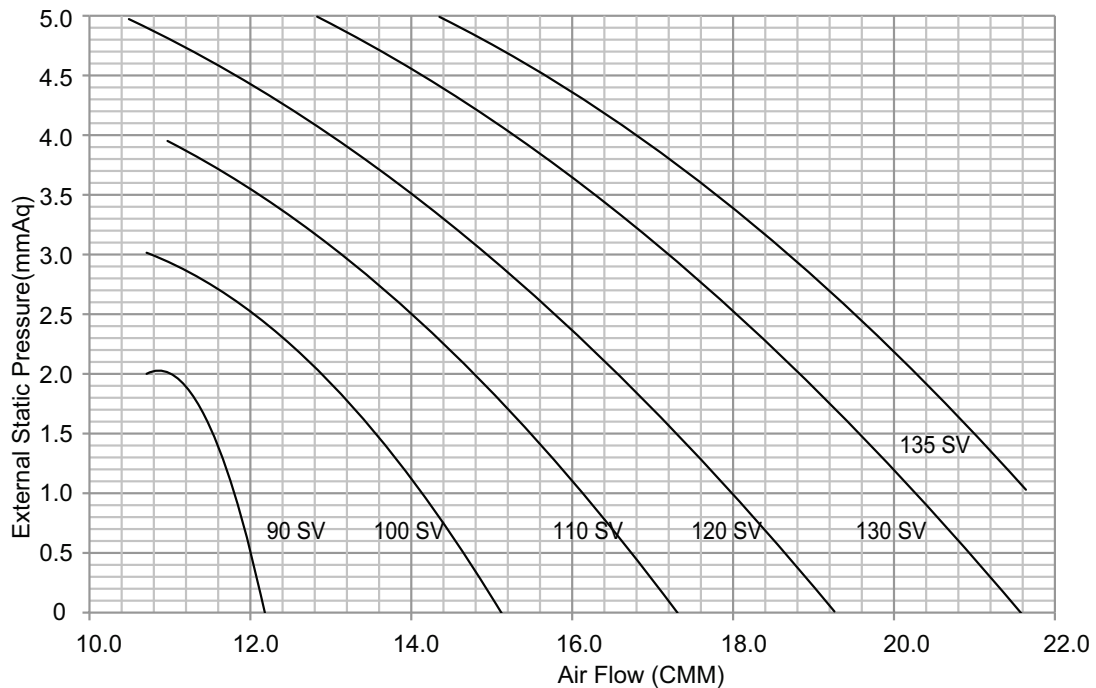

8. Electric Characteristics

Unit					Power Supply	IFM		PI	
Model	Type	Hz	Volts	Voltage Range	MCA	kW	FLA	cooling	Heating
WFCA012RG0A	L1	50	220-240	Max : 264 Min : 198	0.36	0.019	0.29	8	8
WFCA018RG0A	L1				0.39	0.019	0.31	17	17
WFCA025RG0A	L2				0.40	0.024	0.32	20	20
WFCA032RG0A	L2				0.44	0.024	0.35	27	27
WFCA039RG0A	L3				0.46	0.038	0.37	29	29
WFCA055RG0A	L3				0.55	0.038	0.44	44	44
WFCA066RG0A	L3				0.89	0.038	0.71	81	81
WFCA012RG0A	L1	60	220-240	Max : 242 Min : 198	0.36	0.019	0.29	8	8
WFCA018RG0A	L1				0.39	0.019	0.31	17	17
WFCA025RG0A	L2				0.40	0.024	0.32	20	20
WFCA032RG0A	L2				0.44	0.024	0.35	27	27
WFCA039RG0A	L3				0.46	0.038	0.37	29	29
WFCA055RG0A	L3				0.55	0.038	0.44	44	44
WFCA066RG0A	L3				0.89	0.038	0.71	81	81

Symbols

MCA : Minimum Circuit Amperes (A)

kW : Fan Motor Rated Output (kW)

FLA : Full Load Amperes (A)

IFM : Indoor Fan Motor

PI : Maximum Power Input (W)

Note

1. Voltage range

Units are suitable for use on electrical systems where voltage supplied to unit terminals is not below or above the listed range limits.

2. Maximum allowable voltage unbalance between phases is 2%.

3. MCA/MFA

$$MCA = 1.25 \times FLA$$

$$MFA = 1.1 \times MCA, MFA \leq 4 \times FLA$$

(If MFA is smaller than minimum standard value, Use minimum standard value in region for selecting circuit breaker.)

4. Select wire size based on the MCA

5. Instead of fuse, use Circuit Breaker.

9. Sound Levels

9.1 Sound Pressure Levels

Overall

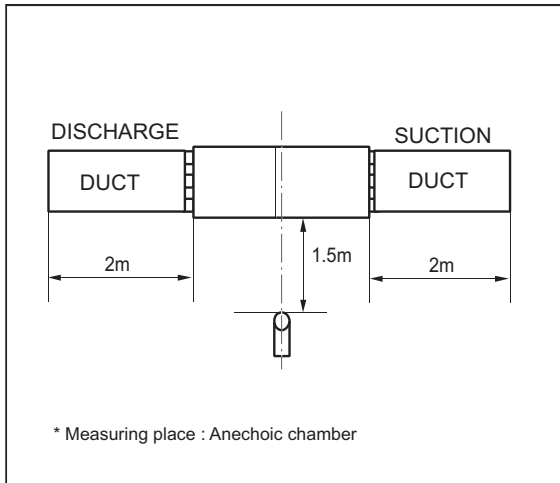

Note

1. Sound measured at some distance away from the center of the unit.
2. Data is valid at free field condition.
3. Reference acoustic pressure 0dB = 20μPa.
4. Data is valid at nominal operation condition.
Refer to the Model Specifications for nominal conditions (Power source and Ambient temperature, etc)
5. Sound levels can be increased in accordance with installation and operating conditions. (Static pressure mode, used air guide, Room target temperature setting, etc)
6. Sound level will vary depending on a range of factors such as the construction (acoustic absorption coefficient) of particular room in which the equipment is installed.
7. Sound pressure level is measured on the rated condition in the anechoic rooms by ISO 3745 standard.
Therefore, these values can be increased owing to ambient conditions during operation.

Model	Sound Pressure Levels [dB(A)]		
	H	M	L
WFCA012RG0A	31	30	29
WFCA018RG0A	33	32	31
WFCA025RG0A	31	30	29
WFCA032RG0A	33	32	31
WFCA039RG0A	28	27	26
WFCA055RG0A	31	28	26
WFCA066RG0A	38	34	31

WFCA012RG0A

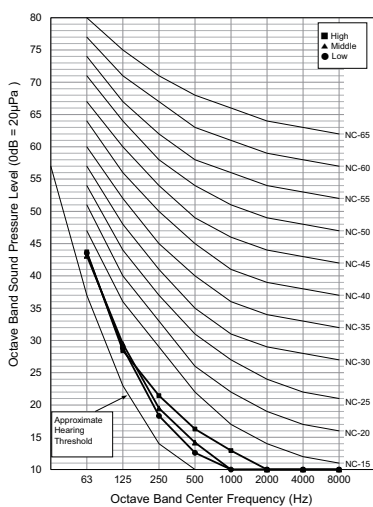

WFCA018RG0A

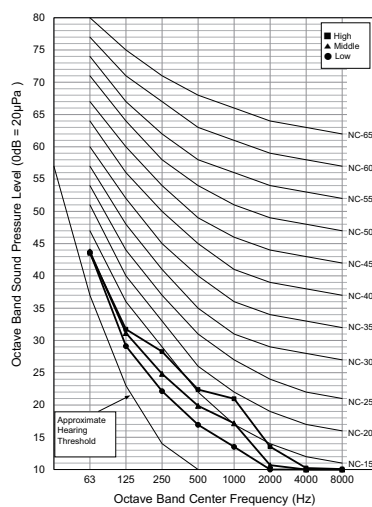

WFCA025RG0A

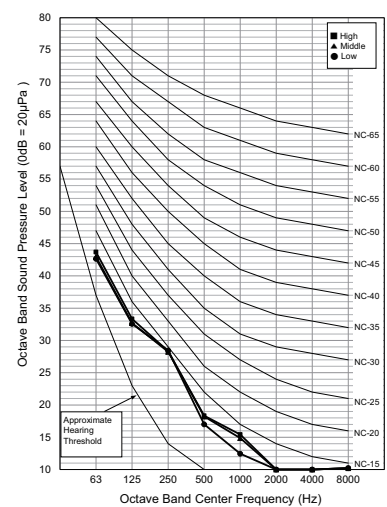

9. Sound Levels

WFCA032RG0A

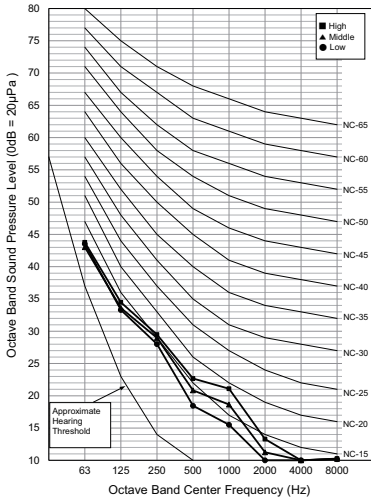

WFCA039RG0A

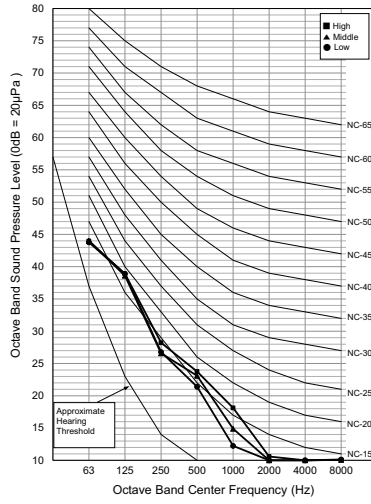

WFCA055RG0A

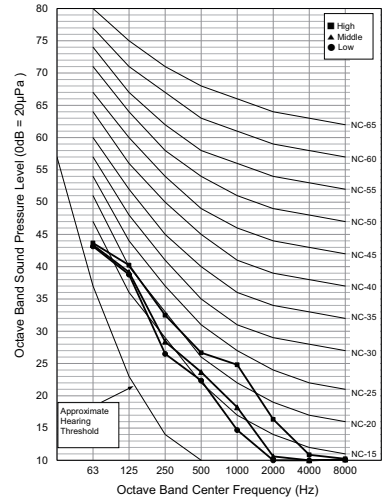

WFCA066RG0A

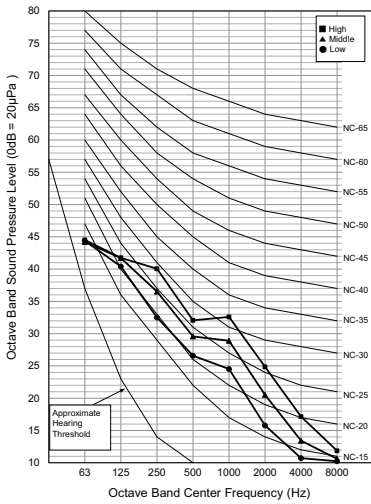

9. Sound Levels

9.2 Sound Power Levels

Note

- Data is valid at diffuse field condition
- Data is valid at nominal operating condition
- Sound level can be increased in static pressure mode or used air guide.
- Sound level will vary depending on a range of factors such as the construction (acoustic absorption coefficient) of particular room in which the equipment is installed.
- Reference acoustic intensity $0\text{dB} = 10\text{E-}6\mu\text{W/m}^2$
- Sound power level is measured on the rated condition in the semi-anechoic rooms by ISO 9614 standard. Therefore, these values can be increased owing to ambient conditions during operation.

Model	Sound Power Levels [dB(A)]		
	H	M	L
WFCA012RG0A	38	36	35
WFCA018RG0A	46	43	39
WFCA025RG0A	41	40	39
WFCA032RG0A	46	43	41
WFCA039RG0A	43	41	40
WFCA055RG0A	47	42	41
WFCA066RG0A	55	52	48

WFCA012RG0A

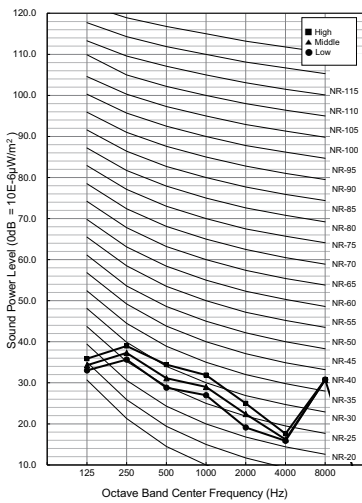

WFCA018RG0A

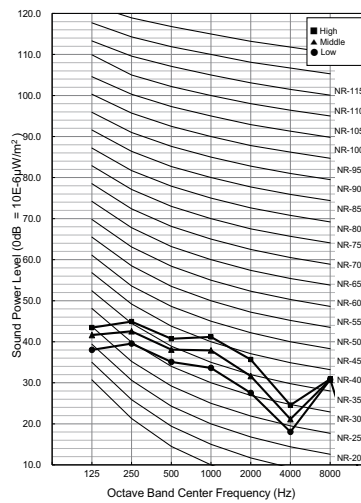

WFCA025RG0A

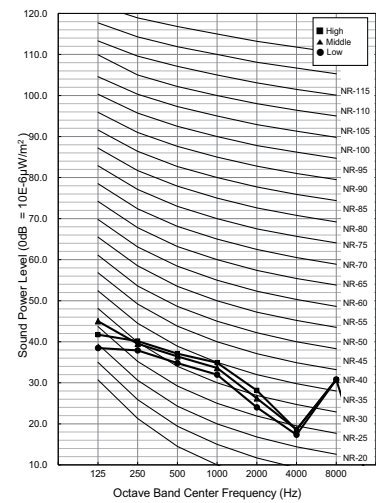

9. Sound Levels

WFCA032RG0A

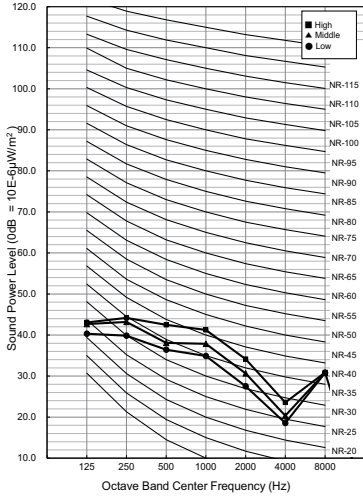

WFCA039RG0A

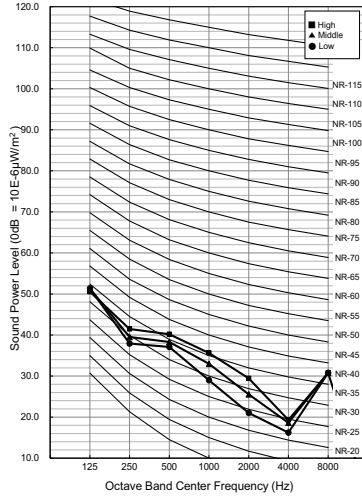

WFCA055RG0A

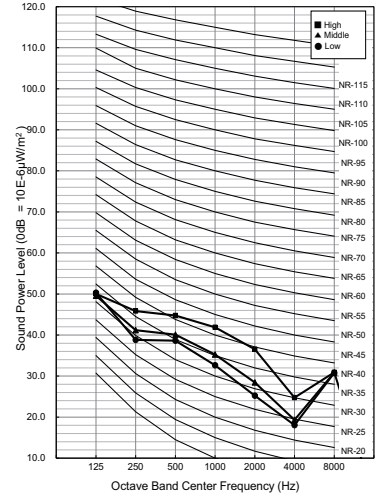

WFCA066RG0A

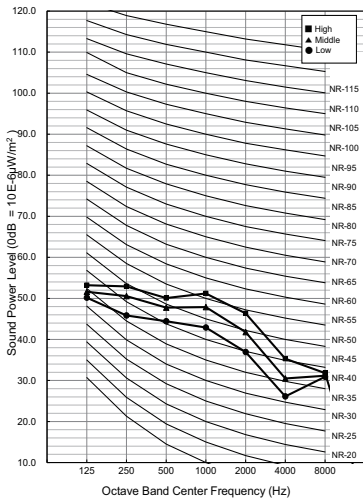

FCU

Installation

- 1. Selection of the best Location**
- 2. Precautions regarding cassette indoor unit installation**
- 3. Connecting pipes**
- 4. Electrical Wiring**
- 5. Drain pipe connection**

1. Installation

1.1 Selection of the best Location

- The unit must be installed indoor area.
- Do not install the unit near the door.
- There should not be any obstacles to the air circulation or installation. Ensure the spaces from the wall, ceiling, or other obstacles.
- The place where the unit is leveled.
- The place shall allow easy water drainage.
- The place where bear a load exceeding four times of weight of the unit.
- The mounting ceiling or wall should be solid enough to protect it from the vibration.
- The place where the unit is not affected by an electrical noise.
- The place where noise prevention is taken into consideration.
- The place where the maintenance space for product is sufficient.
- The servicing inspection hole of the ceiling should be larger than the indoor unit, and that location should be approved by the customer.
- There should not be any heat source or steam near the unit. Avoid the following installation location.
 1. Such places as restaurants and kitchen where considerable amount of oil steam and flour is generated. These may cause heat exchange efficiency reduction, or water drops, drain pump mal-function. In these cases, take the following actions;
 - Make sure that ventilation fan is enough to cover all noxious gases from this place.
 - Ensure enough distance from the cooking room to install the unit in such a place where it may not suck oily steam.

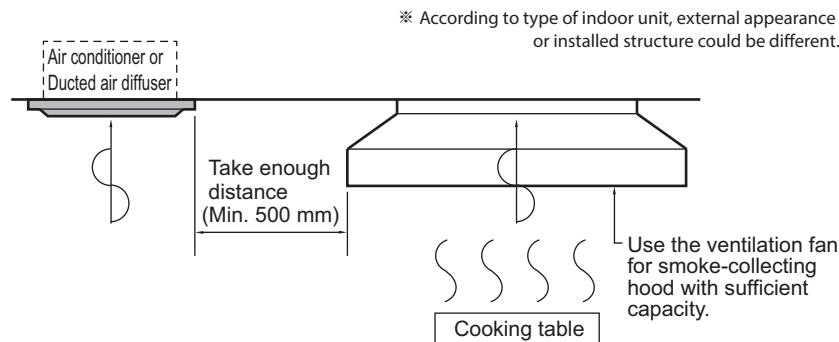

2. Avoid installing the unit in such places where cooking oil or iron powder is generated.
3. Avoid places where inflammable gas is generated.
4. Avoid places where noxious gas is generated.
5. Avoid places near high frequency generators.

⚠ CAUTION

- If the temperature rise above 30°C or the humidity rise above RH 80%, additional insulation working is needed to the unit body for protection of dew formation.
 - Use the glass wool material or polyethylene foam and it make sure to be thick of 10mm at least.

1. Installation

1.2 Precautions regarding cassette indoor unit installation

■ In case of high Ceiling space installation

In general commercial places and offices though the height of the ceiling is 2.7m, and the ceiling height could be over 3 m.

In such cases because of the temperature difference with the floor the heating effect can fall down.

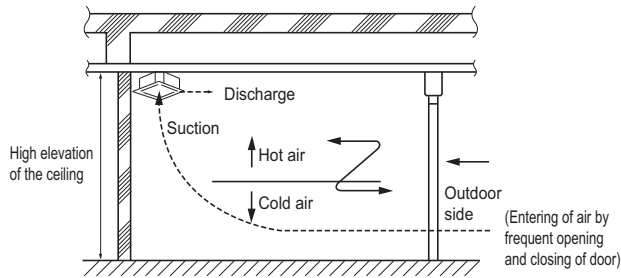

• Countermeasure method

1. Air conditioner should be able to operate in high ceiling operation mode.
2. Plan to install the circulator.
3. The air discharge port should be made to give more airflow to the down floor directions.
4. The gate or exit of the building is protected by dual door system to minimize inflow of outdoor air.

■ In case the floor or surfaces is contact with the outdoor air directly

If the floor of air side conditioned room contact with the outside air, like the store room or garage, the floor temperature will be decreased and users can have a cold feeling in the feet.

In such places where the feet comes in direct contact with floors will give a cold feeling to the foot.

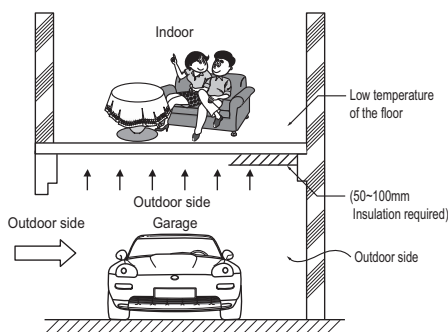

• Countermeasure method

1. Use the carpet on the floor.
(compared to the tiles the carpet over it will have a 3 degree rise in temperature)
2. Insulating the floor.
3. Floor heating.

⚠ CAUTION

In case there is a cold air intake, the duct surface may have some dew drops.

So a insulation on the duct is a must. (Insulation material: a glass wool of thickness 25 mm will be appropriate.)

■ In case of multiple indoor cassette units (recommended)

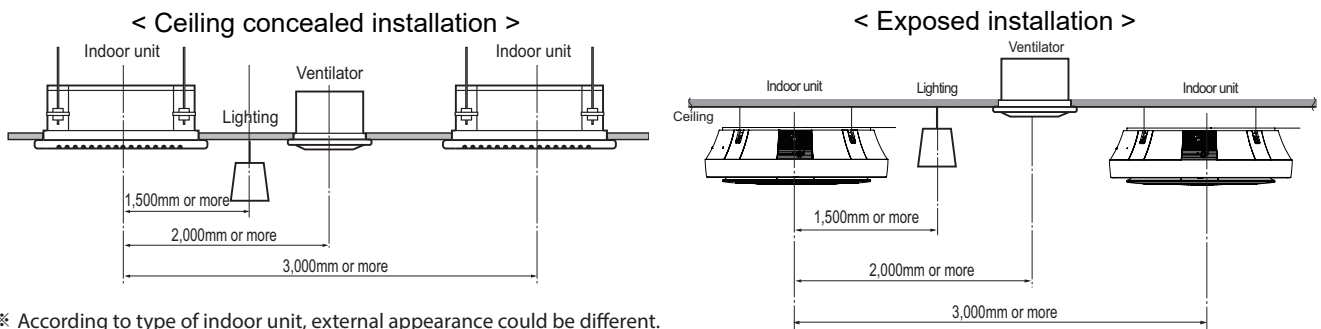

※ According to type of indoor unit, external appearance could be different.

1. Installation

■ In case of installation where high temperature or humidity

- In case of places having the temperature and humidity of the surrounding water sources(sea, river etc.)
- In case the steam is generated between the false ceiling and the ceiling slab due to some nearby by steam source.
- In case of temperature of 30 degree and humidity above 80%, the units body as well as the piping insulation should be strengthened. Refer to the psychrometric chart.

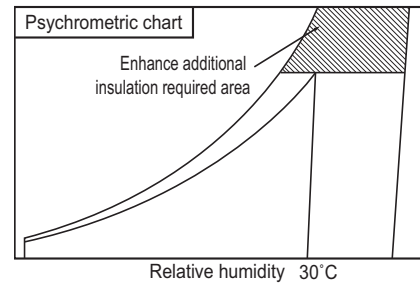

• Countermeasure method

- Indoor unit: Insulate the unit body with some insulation like glass wool at least 10 mm in thickness.
- Refrigerant piping: Increase the piping insulation thickness with thickness above 20 mm.
- Others: Inside the ceiling near th air tight seal places. (No escape of the humidity inside false ceiling)

Additional insulation required

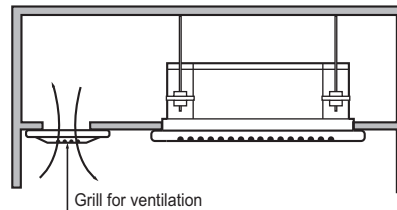
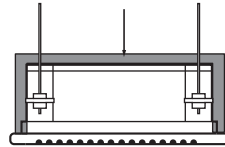

Note

- According to type of indoor unit, external appearance or installed structure could be different.
- According to product type, model line up, sales region..etc, applicability of each chassis could be different.

1. Installation

1.3 Connecting pipes

[Fig.1]

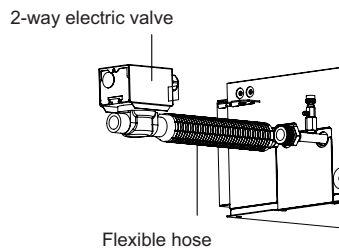

[Fig.2]

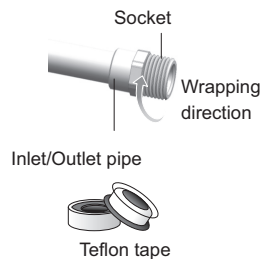

[Fig.3]

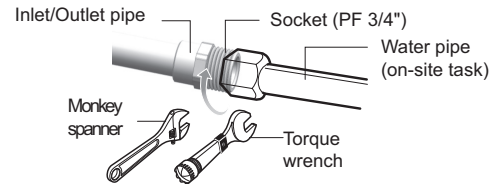

■ Piping installation

⚠ CAUTION

- A difference in pipe fitting standards could cause leakage.
 - When installing, use parts with the same specifications as the product. Refer to the 'Specifications'.
 - Cover all of the water pipes with insulation.
-
- Check the location of the product's inlet and outlet on 'Dimensions' before connecting the pipes.
 - Connecting the water pipes in the opposite directions could result in decreased capacity, noise, and product malfunction.
 - [Fig.1] Be sure to install the 2-way electric valve. Not installing the 2-way electric valve could result in product malfunction and the formation of condensation.

⚠ CAUTION

- Be careful that the water temperature does not go higher than the maximum temperature allowed by the 2-way electric valve.
 - If the pipe temperature is 5 °C or lower or the indoor temperature is 2 °C or lower, the freeze protection function will operate, automatically opening the 2-way electric valve.
Run the pump so that water will circulate in order to prevent freezing. If the valve is not open, run the product. Then, open the valve.
 - When installing the 2-way electric valve, you must use double insulated wire as the connecting wire.
 - Connecting wire should be firmly affixed to pipes so that it doesn't sag.
 - If sagging connecting wire comes in contact or is submerged in water, it could result in fire or electrical shock.
-
- [Fig.2] Use Teflon tape to fully wrap (10-15 times) the threading of the inlet/outlet pipe socket, following the direction of the screw.
 - Connect the water pipe to the product's pipe socket (BSPF G 3/4"). After removing foreign substances from inside the pipe, circulate water through to check whether any parts are leaking.

⚠ CAUTION

- When connecting the pipes, use both tools to ensure that the pipes are sufficiently tightened, as shown in the above picture [Fig.3]. Not using the tools could result in leakage.
- When circulating water, open the air vent and use the tube to remove water in order to fully remove the air inside the valve pipe and coil. Then close the valve. Not doing this could result in decreased performance and noise.

1. Installation

- If water is not managed properly, corrosion, slime, and erosion can occur. This not only decreases performance, but damages the product. Therefore, have a water quality manager make sure that the water quality standards listed in the chart below are always met.

	Item	Cold water
Standards	ph (25 °C)	6.5-8.0
	Conductivity (25 °C μs/cm)	under 200
	Alkalinity (ppm)	under 50
	Water Hardness (ppm)	under 50
	Chloride ions (ppm)	under 50
	Lactate ions (ppm)	under 50
	iron (ppm)	under 0.3
	Sulfurions (ppm)	Not Detected
	Ammonium ions (ppm)	under 0.2
	Silica (ppm)	under 30

1. Installation

1.4 Electrical Wiring

- All field supplied parts and materials, electric works must conform to local codes. Use copper wire only.
 - Follow the "**WIRING DIAGRAM**" attached to the unit body to wire the outdoor unit, indoor units and the remote controller.
 - All wiring must be performed by an authorized electrician.
 - A circuit breaker capable of shutting down the power supply to the entire system must be installed.
-

CAUTION

After the confirmation of the above conditions, prepare the wiring as follows:

- Never fail to have separate power specially for the air conditioner.
 - Provide a circuit breaker switch between power source and the unit.
 - Confirm the Specification of power source.
 - Confirm that electrical capacity is sufficient.
 - Be sure that the starting voltage is maintained at more than 90 percent of the rated voltage marked on the name plate.
 - Confirm that the cable thickness is as specified in the power sources specification. (Particularly note the relation between cable length and thickness.)
 - Do not install the leakage breaker in a place which is wet or moist. Water or moist may cause short circuit.
 - The following troubles would be caused by voltage drop-down.
 - » Vibration of a magnetic switch, damage on the contact point there of, fuse breaking, disturbance to the normal function of a overload protection device.
 - » Proper starting power is not given to the compressor.
-

■ Wiring Connections

- Connect the wires to the terminals on the control board individually according to the outdoor unit connection.
 - Ensure that the color of the wires of outdoor unit and the terminal No. are the same as those of indoor unit respectively.
 - In case of the system with multiple indoor units, mark each indoor unit as unit A, unit B, etc and be sure the terminal board wiring to the outdoor unit and indoor units are properly matched. If wiring and piping between the outdoor unit and an indoor unit are mismatched, the system may cause a malfunction.
-

WARNING

- Make sure that the screws of the terminal are fixed tightly.
 - The screw which fasten the wiring in the casing of electrical fittings are liable to come loose from vibrations to which the unit is subjected during the course of transportation. Check them and make sure that they are all tightly fastened. (If they are loose, it could give rise to burn-out of the wires.)
 - Make sure to attach the sealing material or (field supplied) to hole of wiring to prevent the infiltration of foreign particle from outside. Otherwise a short-circuit may occur inside the electric parts box.
 - When clamping the wires, be sure no pressure is applied to the wire connections by using the included clamping material to make appropriate clamps. Also, when wiring, make sure the cover on the electric parts box fits snugly by arranging the wires neatly and attaching the electric parts box cover firmly. When attaching the electric parts box cover, make sure no wires get caught in the edges. Pass wiring through the wiring through holes to prevent damage to them.
 - Make sure the remote controller wiring, the wiring between the units, and other electrical wiring do not pass through the same locations outside of the unit, separating them properly, otherwise electrical noise (external static) could cause product malfunction.
-

1. Installation

■ Wired remote controller installation (Optional)

Since the room temperature sensor is in the remote controller, the remote controller box should be installed in a place away from direct sunlight, high humidity and direct supply of cold air to maintain proper space temperature. Install the remote controller about 5ft(1.5m) above the floor in an area with good air circulation at an average temperature.

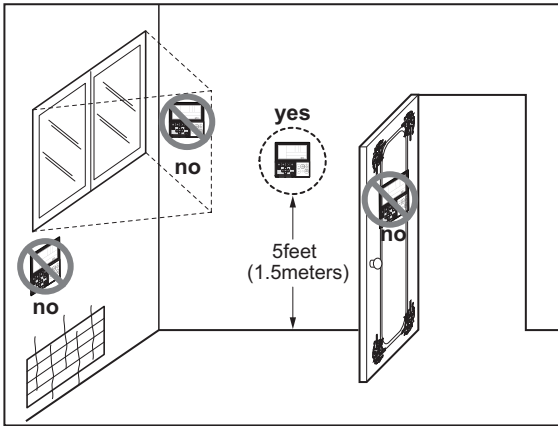

• Do not install the remote controller where it can be affected by :

- Drafts, or dead spots behind doors and in corners.
- Hot or cold air from ducts.
- Radiant heat from sun or appliances.
- Concealed pipes and chimneys.
- Uncontrolled areas such as an outside wall behind the remote controller.
- This remote controller is equipped with a seven segment LED display. For proper display of the remote controller LED's, the remote controller should be installed properly. (The standard height is 1.2~1.5 m from floor level.)

1. Installation

1.5 Drain pipe connection

Important

- The drain pipe should be at least equal in size to drain conduit of the indoor unit.
- The drain pipe is thermally insulated to prevent the formation of condensation inside the pipe.
- The drain up mechanism should be fitted before the indoor unit is installed and when the electricity has been connected a little of water should be added to the drain pan and the drain pump to check and see if it is functioning correctly.
- All connections should be secure. (Special care is needed with PVC pipe)

Dimension of drain pipe connection

- Drain piping must have down-slope (1/50 to 1/100). Be sure not to provide up-and-down slope to prevent reversal flow.
- During drain piping connection, be careful not to exert force on the drain port on the indoor unit.
- The outside diameter of the drain connection on the indoor unit and drain piping fittings should be referenced from 'Specifications' of each models.
 - Piping material: Use the Polyvinyl chloride pipe. VP 20 or VP 25 pipe fittings.
- Be sure to install heat insulation on the drain piping.
 - Heat insulation material: Polyethylene foam with thickness more than 8 mm (5/16 inch).
- Possible drain head height is specified to range of 700 ~ 800 mm(27-6/19 ~ 31-1/2 inch). So the drain head should be installed below that (Refer to Dimensional Drawings of each).

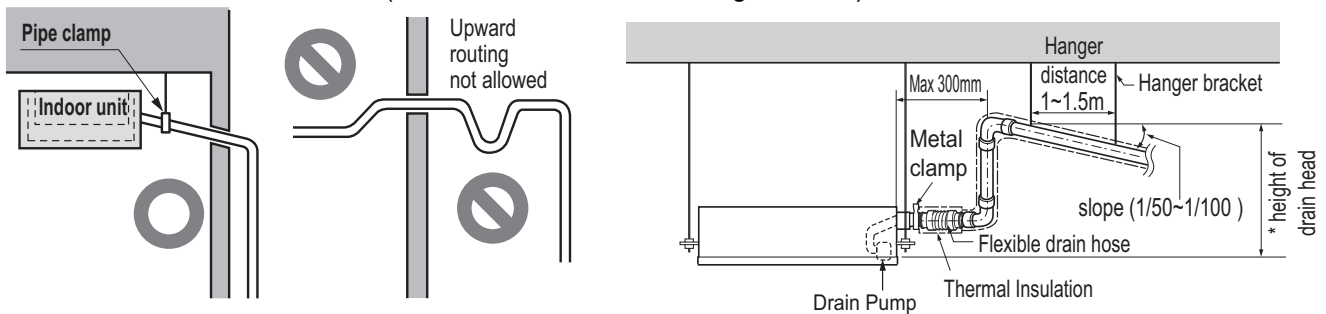

※ * : drain head height should be considered by dimensional drawings of each models.
 ※ According to type of indoor unit, external appearance could be different.

Connection of an auxiliary(flexible) drain hose

- To connect drain pipe to the drain socket on the indoor unit, an auxiliary flexible drain hose should be used. Auxiliary flexible drain hose allows that the drain pipe can be connected to the socket without breaking by excessive strain.

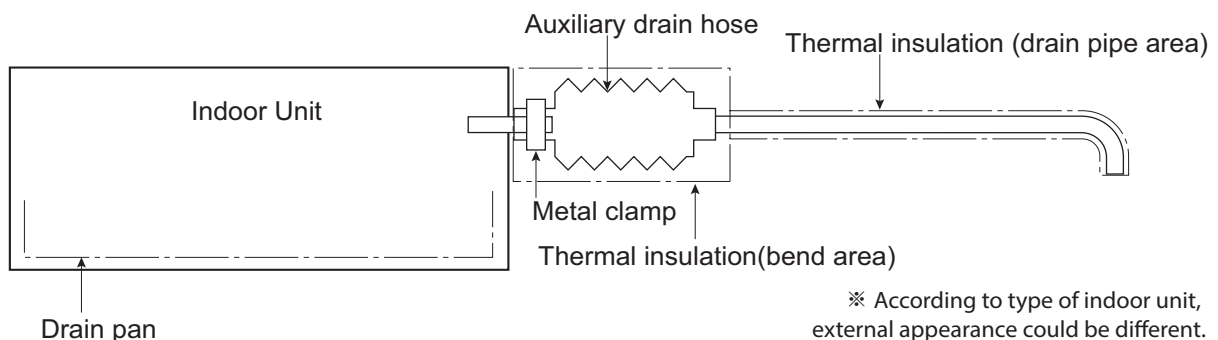

※ According to type of indoor unit, external appearance could be different.

1. Installation

⚠ CAUTION

- The supplied flexible drain hose should not be curved, neither screwed. The curved or screwed hose may cause a leakage of water.
- It is need to insulate the auxiliary drain hose with thermal insulation material.
 - When extending the drain hose, use a commercially available drain extension hose, and be sure to insulate the extended section of the drain hose which is indoors.
 - Make sure the diameter of the extension drain piping is the same as the indoor unit drain hose size or bigger.

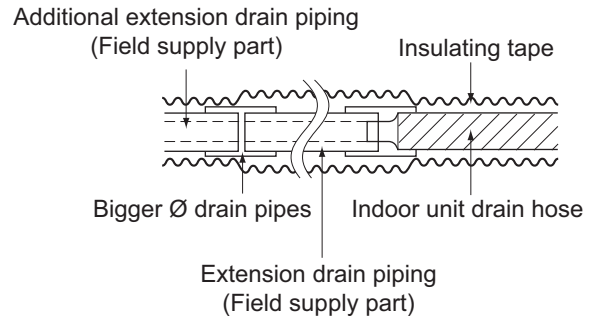

■ Ground drain piping

- Select diameter of drain piping which adapts to the capacity of the unit connected. The pipe down from the combination should be as large as possible.
- The pipe work should be kept as short as possible and the number of indoor units per group kept to a minimum.
- Face the vent pipe opening facing downward to keep foreign matter from penetrating the system.

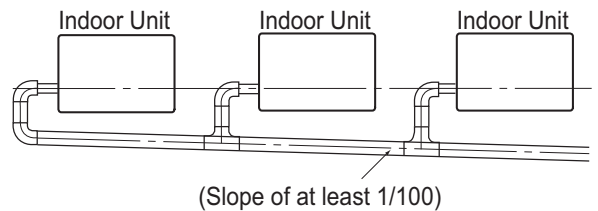
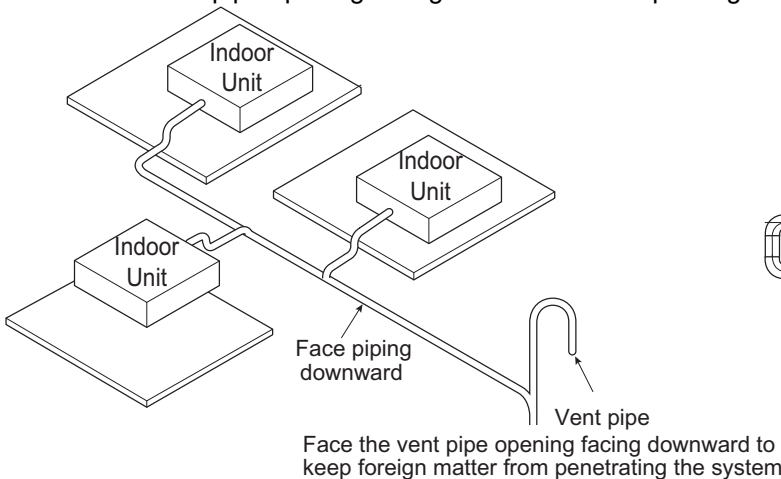

Note

- According to type of indoor unit, external appearance or installed structure could be different.
- According to product type, model line up, sales region..etc, applicability of each chassis could be different.



Air Solution

LG Electronics Inc, 128, Yeoui-daero,
Yeongdeungpo-gu, Seoul, Korea
(07336)
<http://partner.lge.com>

Copyright 2017-2025 LG Electronics Inc.
All Rights Reserved.
Printed in Korea March / 2025

The air conditioners manufactured by LG have received ISO9001 certificate for quality assurance and ISO14001 certificate for environmental management system.
The specifications, designs, and information in this brochure are subject to change without notice.